

**OPEN ACCESS**

## Time resolution measurements with SiPMs coupled to a scintillator

To cite this article: A. Alici *et al* 2018 *JINST* **13** P09012

View the [article online](#) for updates and enhancements.



**IOP | ebooks™**

Bringing you innovative digital publishing with leading voices to create your essential collection of books in STEM research.

Start exploring the [collection](#) - download the first chapter of every title for free.

## Time resolution measurements with SiPMs coupled to a scintillator

A. Alici,<sup>a,b</sup> P. Antonioli,<sup>b</sup> S. Arcelli,<sup>a,b</sup> M. Basile,<sup>b</sup> F. Bellini,<sup>f</sup> F. Carnesecchi,<sup>a,b,e,1</sup>  
D. Cavazza,<sup>b</sup> L. Cifarelli,<sup>a,b,e</sup> F. Cindolo,<sup>b</sup> M. Colocci,<sup>a,b</sup> A. De Caro,<sup>c</sup> D. De Gruttola,<sup>e</sup>  
S. De Pasquale,<sup>c</sup> M. Fusco Girard,<sup>c</sup> D. Hatzifotiadou,<sup>b</sup> N. Jacazio,<sup>a,b</sup> Z. Liu,<sup>d</sup>  
O. Maragoto Rodriguez,<sup>d</sup> A. Margotti,<sup>b</sup> E. Meninno,<sup>c</sup> R. Nania,<sup>b,e</sup> F. Noferini,<sup>b</sup> O. Pinazza,<sup>b</sup>  
R. Preghenella,<sup>b</sup> E. Scapparone,<sup>b</sup> G. Scioli,<sup>a,b</sup> J. Wilkinson,<sup>b</sup> M.C.S. Williams,<sup>b</sup>  
C. Zampolli,<sup>b,f</sup> A. Zichichi<sup>b,e</sup> and R. Zuyeuski<sup>d,e</sup>

<sup>a</sup>Dipartimento di Fisica e Astronomia dell'Università, Bologna, Italy

<sup>b</sup>Sezione INFN, Bologna, Italy

<sup>c</sup>Dipartimento di Fisica dell'Università and INFN, Salerno, Italy

<sup>d</sup>World Laboratory, Geneva, Switzerland

<sup>e</sup>Museo Storico della Fisica e Centro Studi e Ricerche "Enrico Fermi", Roma, Italy

<sup>f</sup>CERN, Geneva, Switzerland

E-mail: [francesca.carnesecchi@bo.infn.it](mailto:francesca.carnesecchi@bo.infn.it)

**ABSTRACT:** This paper reports on the results of time resolution measurements of detectors consisting of SiPMs coupled to a scintillator. The R&D has been performed both in a cosmic-ray setup, at the Bologna INFN laboratories, and in a beam test, at the CERN T10 beam line. Different couplings, direct or by means of optical fibres, have been tested. The measurements indicate that to reach better time resolutions, it is important to have a direct coupling between the SiPM and the scintillator. A time resolution of 67 ps has been achieved, for the direct coupling, broadened by the full electronics chain jitter.

**KEYWORDS:** Instrumentation and methods for time-of-flight (TOF) spectroscopy; Photon detectors for UV, visible and IR photons (solid-state) (PIN diodes, APDs, Si-PMTs, G-APDs, CCDs, EBC-CDs, EMCCDs etc); Scintillators, scintillation and light emission processes (solid, gas and liquid scintillators); Timing detectors

<sup>1</sup>Corresponding author.

---

## Contents

<b>1</b>	<b>Introduction</b>	<b>1</b>
<b>2</b>	<b>Detectors</b>	<b>2</b>
<b>3</b>	<b>Preliminary measurements</b>	<b>3</b>
<b>4</b>	<b>Experimental setup</b>	<b>4</b>
4.1	Cosmic-ray setup	4
4.2	Beam test setup	5
<b>5</b>	<b>Analysis</b>	<b>6</b>
<b>6</b>	<b>Results and discussion</b>	<b>8</b>

---

## 1 Introduction

High energy physics experiments (as at the LHC) rely increasingly on detectors capable covering large areas, with good time resolution performance, insensitivity to magnetic fields, high efficiency and low cost. Silicon PhotoMultipliers (SiPM) [1–8], coupled to scintillators, satisfy all these characteristics. SiPMs are insensitive to magnetic field up to at least 7 T, contrary to standard PhotoMultipliers (PMs). Moreover, they are compact, have a low power consumption, they can perfectly work at cryogenic temperature and they have single-photon detection capability. All these features, combined with an excellent intrinsic time resolution, can lead to a cutting-edge detector for timing applications, suitable both for nuclear and medical physics. Moreover, with the higher pile-up at the next-generation hadron colliders, HL-LHC [9] and the FCC [10], a time resolution of a few tens of picoseconds is necessary. The spatial information alone will be not sufficient to separate the multiple event vertices from overlapped interactions thus the idea is to use a precise time information associated to each track (and possibly of each hit of a track), to identify the corresponding interaction.

In this paper a study of the time resolution of a complete particle detector prototype (SiPM + scintillator) is reported. The results obtained using both a cosmic-ray setup and a beam test are shown. The experimental setups are illustrated together with the front-end and readout electronics used to perform the measurements. A cosmic-ray test setup has been installed at the Bologna INFN laboratories, to perform preliminary studies. During this phase the possibility to use optical fibres to move the SiPM sensor away from a hypothetical high-radiation area was also investigated; in particular the degradation of the time resolution with increasing fibre length. The front-end and readout electronics were optimised for the time performance. Finally, dedicated measurements at the T10 beam line at CERN PS accelerator were performed.

## 2 Detectors

The SiPMs under test are the MPPC (Multi-Pixel Photon Counter) S12572-050P [11] produced by Hamamatsu. They have an active area of  $3 \times 3 \text{ mm}^2$  with a  $50 \mu\text{m}$  pixel pitch. In table 1 the main characteristics of this photo-detector are reported. For a wavelength between about 375 nm and 550 nm the Photon Detection Efficiency (PDE) is larger than 30%.

**Table 1:** Properties of S12572-050P MPPC.

Parameter	S12572-050P
Effective area	$3 \times 3 \text{ mm}^2$
Pixel pitch	$50 \mu\text{m}$
Number of pixels	3600
Fill factor	62 %
Spectral range $\lambda$	320–900 nm
Gain	$1.25 \cdot 10^6$
Time resolution (FWHM Single photon level)	250 ps
Recommended op. voltage	$67.6 \pm 10.0 \text{ V}$

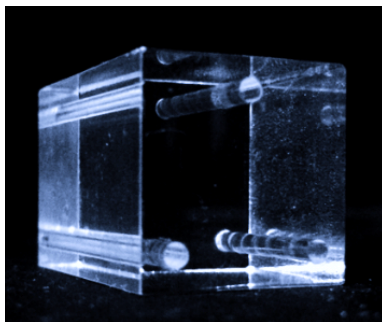

**Figure 1:** Picture of the BC-420 scintillator. Three holes for fibres are visible.

**Table 2:** Properties of the plastic scintillator BC-420.

Parameter	BC-420
Base	Polyvinyltoluene
Wavelength of Max. Emission	391 nm
Refractive index	1.58
Bulk Light Attenuation Length	110 cm
Ratio $H : C$ Atoms	$\sim 1.1$
Rise Time	0.5 ns
Decay Time	1.5 ns

The SiPMs were tested coupling them either directly or by means of optical fibres to a plastic organic scintillator. A plastic scintillator BC-420 [12] of  $2 \times 2 \times 3 \text{ cm}^3$  has been used, see figure 1. This scintillator has been developed to perform ultra-fast time measurements; in table 2 the main characteristics of the scintillator are reported. The speed of photons inside the scintillator is  $19 \text{ cm/ns}$ . This means, for a 3 cm path length, a transit time of 158 ps; so the arrival time spread in 3 cm is  $158/\sqrt{12} = 46 \text{ ps}$ .<sup>1</sup>

During all the tests, the scintillator was read by two SiPMs, mounted on opposite sides of the scintillator as shown in figure 2(a).

An optical fiber plastic WLS BCF-92 [13] of 2 mm of diameter was used. These are fast wavelength shifter fibres (decay time 2.7 ns) and they are used here just as light guides; however

<sup>1</sup>This is just a lower limit, since we are considering only the direct photons while the reflected photons are not considered.

they shift the light from blue to green, with an emission peak of 492 nm. This is within the MPPC wavelength acceptance. The time resolution behaviour as a function of the fiber's length has been studied. Fibres of two different lengths have been used: 10 cm and 35 cm.

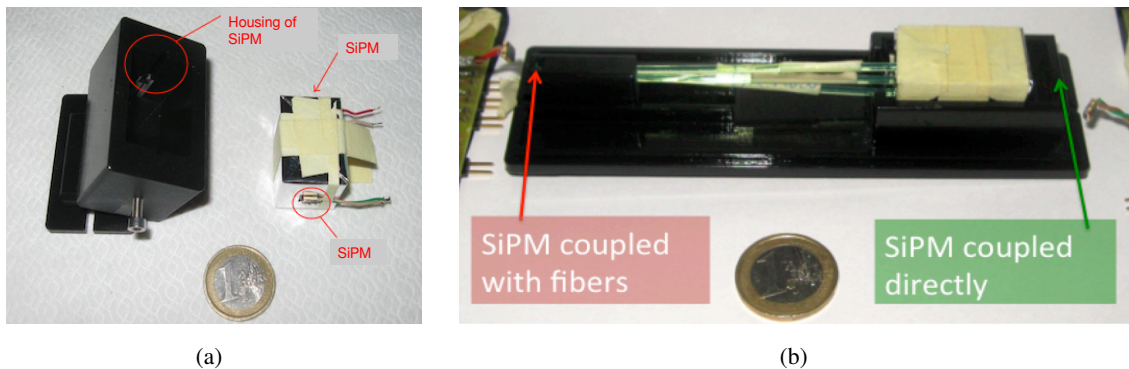

**Figure 2:** Picture showing the SiPM couplings to the scintillator; direct (a) and by means of fibres (b).

### 3 Preliminary measurements

An important measurement is the voltage to apply to the SiPM. To identify the breakdown voltage, the current as a function of the reverse applied voltage ( $I - V$  curve) was measured. In figure 3(a) the  $I - V$  curves for two tested SiPMs are shown (named *A* and *B* in the legend). In both cases above 65.6 V (breakdown voltage) the current starts to increase with reverse bias. The maximum operation voltage has been set to 70 V (overvoltage of 70 V – 65.6 V = 4.4V); above that value the current increases beyond acceptable values.

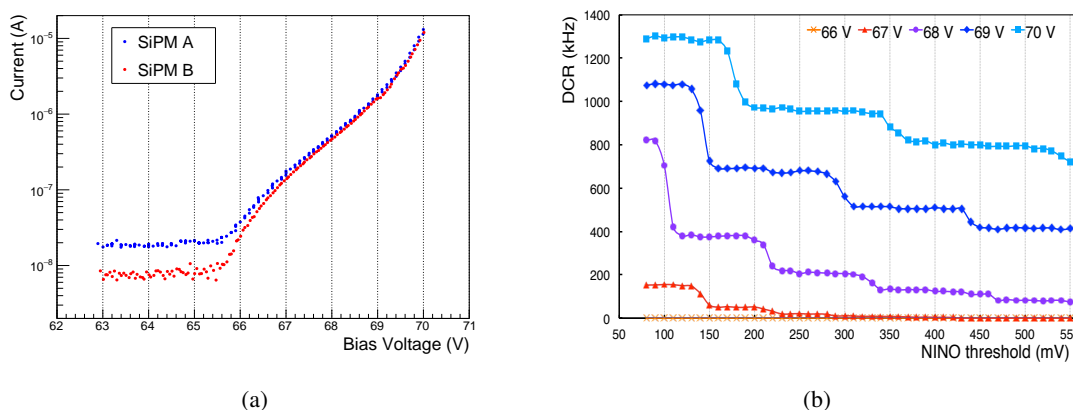

**Figure 3:** Measurements on SiPM S12572-050P produced by Hamamatsu of  $3 \times 3 \text{ mm}^2$  active area. (a) Current versus voltage applied (Bias Voltage) curves ( $I - V$  curves) of two (*A* and *B*) tested SiPMs. (b) The Dark Count Rate (DCR) versus the NINO threshold for various bias voltages.

Another important measurement is the Dark Count Rate (DCR). The SiPM, of  $3 \times 3 \text{ mm}^2$  active area and with 3600 pixels, has been mounted in a temperature controlled ( $20^\circ\text{C}$ ) dark box. The NINO-ASIC chip (see section 4.1 for details) has been used as the front-end amplifier/discriminator. In figure 3(b) the DCR versus the NINO threshold is plotted for several bias voltage. It should be pointed out that the value of threshold refers to the differential voltage applied to the NINO threshold input. This plot is important in order to understand the threshold. When a SiPM pixel fires (no matter if due to noise or to a photon) it generates a signal; as each pixel operates in Geiger mode, the signal produced by a single detected photon is the same. A single pixel firing can induce a breakdown in a neighbouring pixel due to cross talk, thus a given dark count can correspond to one, two, three or more pixels firing; this should be observed in the DCR versus threshold plot. Indeed, these steps are evident in figure 3(b): starting from a plateau, with a threshold value below the single pixel firing signal, each step corresponds to one, two, three or more pixels firing. Furthermore the distance between two steps increases for higher voltage; this is due to the sequential increase of the gain.

## 4 Experimental setup

In the direct coupling, two SiPMs are placed on two opposite surfaces of the scintillator (see figure 2(a)) coupled by optical grease; the two SiPMs are at a distance of 3 cm one to the other. In the case of coupling by means of fibres, three WLS were used, inserted into the scintillator (through three previously-drilled holes, see figure 1); in figure 2(b) a photo of the configuration for three fibres of 10 cm is shown.

### 4.1 Cosmic-ray setup

To measure the time resolution of the SiPM a cosmic-ray telescope (figure 5(a)) has been set up at the Bologna INFN laboratories. The telescope is made of three plastic scintillators; the top (A) and bottom (C) ones are coupled to standard PMs and are used to trigger the acquisition system and to generate the reference ( $t_0$ ) for the time measurements. The middle scintillator (B) is coupled to the SiPMs under test. Finally, the telescope was inserted inside a box in order to maintain a constant temperature of  $20^\circ\text{C}$  using a chiller. This allowed to keep constant the SiPM performances, requirement particularly important in a cosmic ray test due to the long period of data taking needed to collect an adequate statistical sample.

A NINO-ASIC card [14, 15] has been used as the front-end amplifier/discriminator; it is a low-power ultrafast amplifier and discriminator with a differential input and LVDS output signals. Important characteristics are a leading edge of the output signal with a low jitter ( $< 25 \text{ ps}$ ) and an output signal width correlated to the charge of the input signal (Time Over Threshold, TOT). To adapt the SiPM signal to the differential signal needed as input from the NINO-ASIC chip, a dedicated circuit has been realised, see figure 4.

The LVDS output signals from the NINO have been adapted and measured using standard CAMAC modules: CAEN C414 Time to Digital Converter (TDC) (25 ps time resolution) and a CAEN C205 Charge-Integrating ADC (CIA) [16].

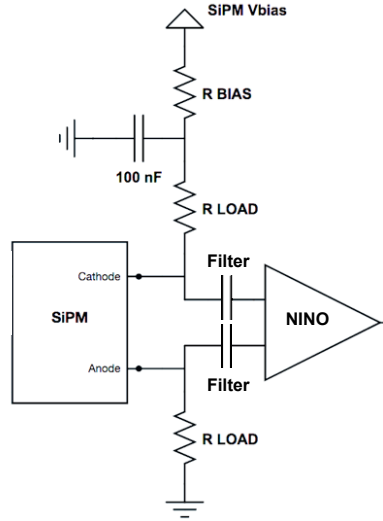

**Figure 4:** Custom adapt circuit from SiPM terminal to NINO-ASIC chip input.

#### 4.2 Beam test setup

The SiPMs and scintillator have also been tested at the T10 test beam line at CERN; the beam was composed mainly of negative pions of 5 GeV/c momentum; the size of the beam spot was 1 cm<sup>2</sup>. In figure 5(b), a schematic view of the experimental setup is reported. Three sets of scintillators coupled to PMs have been used for the trigger. In particular, starting from the beam entrance, downstream of the SiPM under test, the first set (*S1-S2*, *S3-S4*) consists of two orthogonal scintillator bars (2 × 2 × 10 cm<sup>3</sup>), read at each end by PMs. The second and the third sets (*P1-P2* and *P3-P4*) are made of a pair of crossed scintillators (1 × 1 cm<sup>2</sup> and 2 × 2 cm<sup>2</sup> respectively) read by PMs. *S1*, *S2*, *S3* and *S4* are also used as timing reference, *t*<sub>0</sub>, by means of the average between all the detectors ((*S1* + *S2* + *S3* + *S4*)/4). A *t*<sub>0</sub> time resolution of 40–50 ps has been measured; this has been evaluated from the time difference ((*S1* + *S2*)/2 – (*S3* + *S4*)/2).

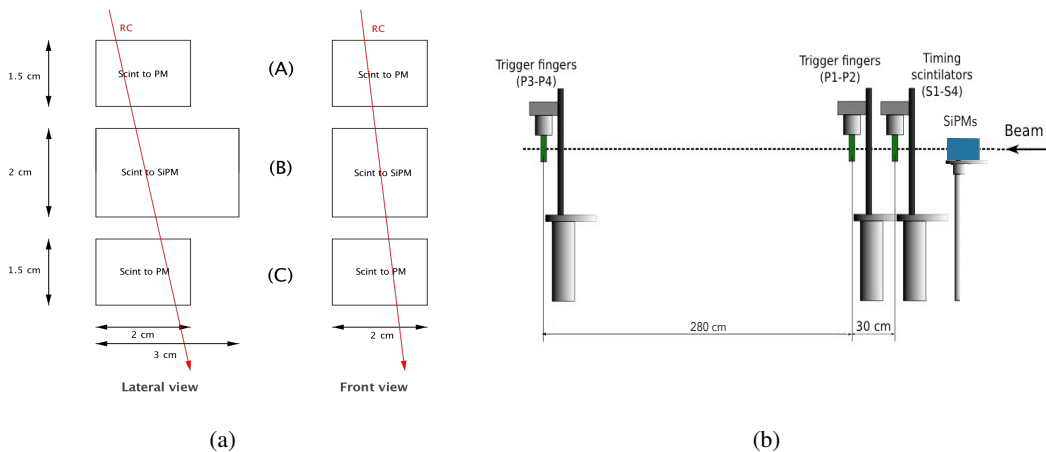

**Figure 5:** Schematic view of the cosmic-ray (a) and beam test (b) setup at the INFN-Bologna laboratories and at CERN T10, respectively.

By means of an ad hoc circuit (see section 4.1), the NINO-ASIC card has been used as front-end electronics. A VME module High Precision TDC (HPTDC) [17] was used as readout electronics. The HPTDC can simultaneously measure the leading and the trailing edges of a signal, with a time resolution of 25 ps.

## 5 Analysis

In this section the data analysis and the results will be discussed. In the cosmic-ray setup for each event, the time and charge collected by the trigger-PMs are recorded and can be used for the selection criteria. For the beam test the trigger-PMs charge was not recorded so the selection criteria were based solely on the timing.

For each event (both in cosmic-ray and beam test set up) the time and the Time Over Threshold (related to the charge) of the two SiPMs were measured. In figure 6 a typical TOT distribution in the beam test setup is shown. The time measurements have been corrected for the time slewing

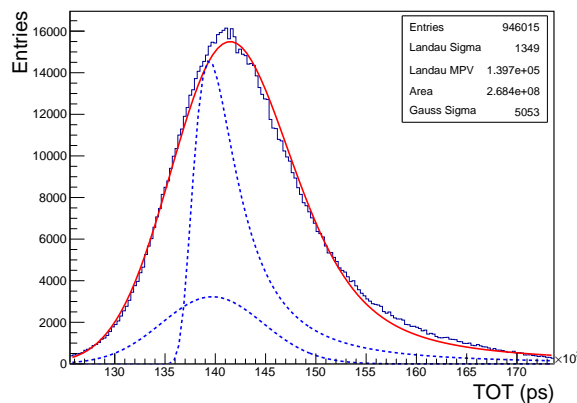

**Figure 6:** The TOT distribution of a SiPM in the beam test setup; in this particular case a voltage on the SiPM of 69.5 V was applied. To fit it a convolution of a Gaussian and a Landau was used.

effect, using the TOT variable. In figure 7(a) the correlation between the TOT and the time signal of a SiPM is shown; the distribution has been fitted by means of a third degree polynomial. In figure 7(b) the time measurements corrected for time slewing (subscript  $t_s$ ) versus TOT is reported. A projection of figure 7(b) along the Y-axis (figure 8(b)) leads to the  $\Delta t$  distributions, discussed later in this section, from which the time resolution can be calculated. Through these time slewing corrections, an improvement up to 16% of the time resolution has been achieved.

To calculate the time resolution (after the time slewing corrections), a different approach has been chosen depending on the experimental setup.

For cosmic-ray (cr) events, the difference ( $\Delta t$ ) of the arrival times of the two SiPM signals has been considered; in this way it is possible to eliminate systematic errors due the observed variation of the trigger signal over the long periods of data acquisition (a problem not present in the beam test). It should be pointed out that by considering the time difference we are including the indetermination related to the hit position in the scintillator, the SiPM and electronic jitter and, in the corresponding test, the jitter introduced by the fibres. However the scintillator-intrinsic jitter



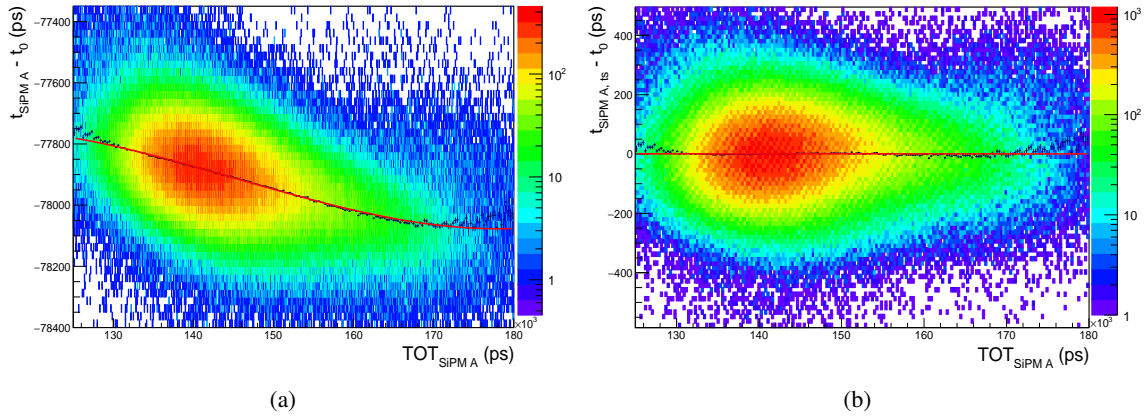

**Figure 7:** Correlation between the time measurement  $t_{\text{SiPMA}} - t_0$  and the  $TOT_{\text{SiPMA}}$  before (a) and after (b) the time slewing correction in the beam test.

contribution is excluded. The  $\Delta t$  distribution obtained in various configurations (with and without fibres) has been fitted using a Gaussian function; in figure 8(a) the  $t$  distribution for the direct coupling is reported.

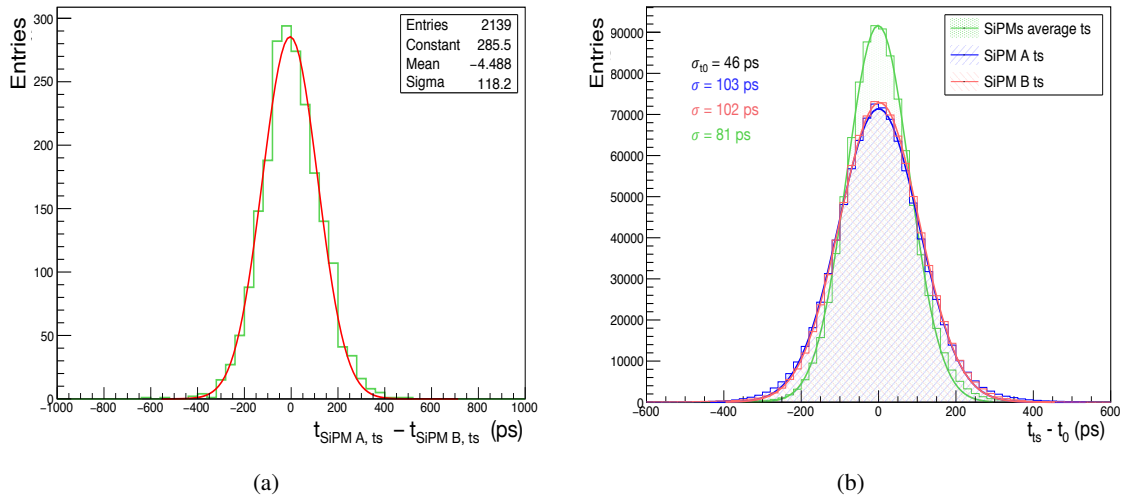

**Figure 8:** (a)  $\Delta t$  distribution obtained in the cosmic-ray setup for the case of SiPMs directly coupled to the scintillator with an applied voltage of 68.5 V. The subscript  $ts$  indicates the measurements after the time slewing correction has been applied. (b)  $\Delta t$  distributions obtained in a beam test setup with an applied voltage of 69.5 V and a NINO threshold of 400 mV; the time resolutions of the three plotted distributions are reported in addition to the  $t_0$  time resolution.

In the case of direct coupling, the time resolution is obtained from the  $\sigma$  using the following formula:

$$\sigma_{\text{direct}_{\text{cr}}} = \frac{\sigma}{\sqrt{2}}. \quad (5.1)$$

In the case of the coupling by means of fibres, since in this scenario only one SiPM was coupled by means of fibres, while the other was coupled directly (see figure 2(b)), the final time resolution is obtained using the following formula:

$$\sigma_{\text{fiber}_{\text{cr}}} = \sqrt{\sigma^2 - \sigma_{\text{direct}_{\text{cr}}}^2}, \quad (5.2)$$

where  $\sigma$  is the one obtained from the Gaussian fit.

In the beam test (bt) setup the results both for the time measured for a single SiPM and for the average of the two SiPMs have been analysed always considering the time difference with respect to  $t_0$  (given by PMs, see section 4.2). The  $\Delta t$  distributions obtained have been fitted using a Gaussian function, see figure 8(b). The  $\sigma$  of these distributions are related to the detector time resolution; in the case of the average of the two SiPMs the final time resolution will be comprehensive of the resolution of the whole system, i.e. of the scintillator plus the two SiPMs (plus electronics). The time resolution  $\sigma_{\text{bt}}$  of the detector is obtained from the  $\sigma$  of the gaussian fit using the following formula:

$$\sigma_{\text{bt}} = \sqrt{\sigma^2 - \sigma_{t_0}^2}. \quad (5.3)$$

To compare the cosmic-ray results to the beam test results, also in this case, the difference of the arrival times of the two SiPM signals has been considered.

## 6 Results and discussion

All the time resolutions reported include also the contributions of the whole electronic chain (front-end and readout electronics). The final results for the cosmic-ray setup obtained in the various configurations are reported in table 3; these resolutions include the jitter contributions due to the hit position in the scintillator, the SiPM, the electronics chain and, in the corresponding test, the contribution introduced by the fibres. Since the analysis method uses the difference of the signals, the scintillator intrinsic jitter contribution is excluded. As expected, with increasing fiber length there is a worsening of the time resolution. A time resolution of  $84 \pm 5$  ps per single SiPMs has been achieved for the direct coupling.

**Table 3:** Time resolution results for the cosmic-ray setup.

Cosmic rays	Coupling to Scintillator	Voltage (V)	Time resolution (ps)
	Direct	68.5	$84 \pm 5$
	Fibres 10 cm long	68.5	$125 \pm 5$
	Fibres 35 cm long	68.5	$139 \pm 6$

In the beam test setup the time resolution versus both the NINO threshold and voltage applied to the SiPMs has been studied. In particular the NINO threshold was changed between (200–500) mV without any significant variation. The voltage was also modified from 67.5 V to the maximum operation voltage (70 V) (see figure 3(a)). The results are reported in figure 9. As expected the time resolution is worst for lower voltages, with a degradation of  $\sim 14\%$  and a plateau for higher voltages.

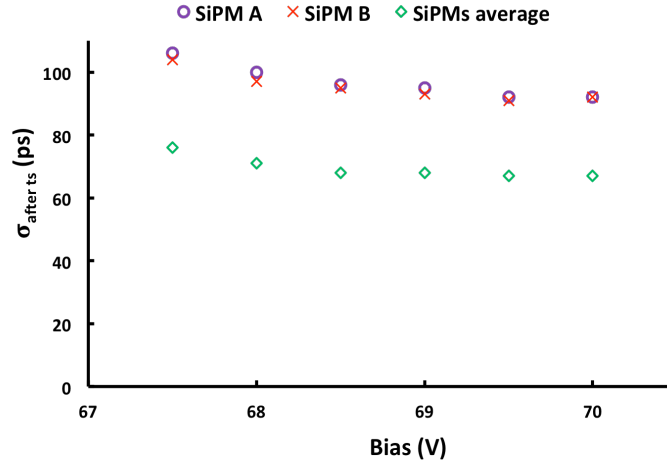

**Figure 9:** Final time resolutions  $\sigma_{\text{SiPM A,ts}}$ ,  $\sigma_{\text{SiPM B,ts}}$ ,  $\sigma_{\text{SiPMs av,ts}}$  for the beam test setup, after the time slewing correction, versus the applied bias voltage. The NINO threshold value used was 400 mV.

In table 4 the beam test results at 69.5 V are reported. For the single SiPM a time resolution of  $91 \pm 3$  ps is obtained, including all the jitter contributions (due to the scintillator intrinsic jitter contribution, the hit position in the scintillator, the SiPM and the electronics chain).

Starting from the distribution of the difference of the two SiPMs signals, a time resolution of  $91 \pm 3$  ps has been achieved. This results is totally compatible with the one obtained from the single SiPMs distributions, even if in the difference case the scintillator intrinsic jitter contribution is excluded. We can then conclude that the scintillator intrinsic jitter is negligible and we can therefore compare the beam test results with the cosmic-ray results: the single SiPM time resolution is compatible with the cosmic-ray results (for the direct coupling case).

**Table 4:** Time resolution results for the beam test setup.

Beam test	Voltage (V)	Time resolution (ps)
SiPM A	69.5	$92 \pm 3$
SiPM B	69.5	$91 \pm 3$
SiPMs average		$67 \pm 3$

A final time resolution for the average signal of the two SiPMs of  $67 \pm 3$  ps has been achieved. It should be pointed out that this result has been obtained without any temperature control and it also includes the jitter due to the whole electronics chain.

The measurements presented here indicate that to reach a better time resolution of tens of picoseconds, it is important to have a direct coupling between the SiPM and the scintillator. The results also indicate that this goal is achievable with just two SiPMs at room temperature. Further improvements in the electronics and the new generation of SiPMs will further reduce the present achieved time resolution.

## References

- [1] P. Buzhan et al., *Silicon photomultiplier and its possible applications*, *Nucl. Instrum. Meth. A* **504** (2003) 48.
- [2] S. Cova et al., *Evolution and prospects for single-photon avalanche diodes and quenching circuits*, *J. Mod. Opt.* **51** (2004) 1267.
- [3] V. Golovin and V. Savaliev, *Novel type of avalanche photodetector with geiger mode operation*, *Nucl. Instrum. Meth. A* **518** (2004) 560.
- [4] D. Renker, *Geiger-mode avalanche photodiodes, history, properties and problems*, *Nucl. Instrum. Meth. A* **567** (2006) 48.
- [5] N. Otte, *The Silicon Photomultiplier: A New Device for High Energy Physics, Astroparticle Physics, Industrial and Medical Applications*, *eConf C0604032* (2006) 0018.
- [6] D. Renker and E. Lorenz, *Advances in solid state photon detectors*, *2009 JINST* **4** P04004.
- [7] R. Pagano et al., *Dark current in silicon photomultiplier pixels: Data and model*, *IEEE Trans. Electron Dev.* **59** (2012) 2410.
- [8] A. Heering et al., *Effects of very high radiation on sipms*, *Nucl. Instrum. Meth. A* **824** (2016) 111.
- [9] G. Apollinari et al., *High-Luminosity Large Hadron Collider (HL-LHC): Preliminary Design Report*, *CERN-2015-005* (2015).
- [10] M. Benedikt and F. Zimmermann, *Future Circular Colliders*, *Proc. Int. Sch. Phys. Fermi* **194** (2016) 73.
- [11] Datasheet Hamamatsu - MPPC, <https://seltokphotonics.com/upload/iblock/118/1186141f87bc6da48efe2c465195e38d.pdf>.
- [12] Datasheet Plastic Scintillator, [https://www.crystals.saint-gobain.com/sites/imdf.crystals.com/files/documents/sgc-bc418-420-422-data-sheet\\_69699.pdf](https://www.crystals.saint-gobain.com/sites/imdf.crystals.com/files/documents/sgc-bc418-420-422-data-sheet_69699.pdf).
- [13] Datasheet Scintillating Fiber, <http://www.crystals.saint-gobain.com/products/scintillating-fiber>.
- [14] F. Anghinolfi et al., *NINO: An ultra-fast and low-power front-end amplifier/discriminator ASIC designed for the multigap resistive plate chamber*, *Nucl. Instrum. Meth. A* **533** (2004) 183.
- [15] F. Anghinolfi et al., *NINO: An ultrafast low-power front-end amplifier discriminator for the time-of-flight detector in the ALICE experiment*, *IEEE Trans. Nucl. Sci.* **51** (2004) 1974.
- [16] Datasheet Camac Modules, <http://www.caen.it/servlet/SearchLibraryByType?type=Manuals>.
- [17] Datasheet HPTDC, <http://www.caen.it/csite/CaenProd.jsp?idmod=789&parent=11>.