

PAPER • OPEN ACCESS

## A small scale remote cooling system for a superconducting cyclotron magnet

To cite this article: F. Haug *et al* 2017 *IOP Conf. Ser.: Mater. Sci. Eng.* **171** 012038

View the [article online](#) for updates and enhancements.

### Related content

- [Quench analysis of a novel compact superconducting cyclotron](#)  
Sundeep Ghosh, Anjan Dutta Gupta, Malay Kanti Dey *et al.*
- [Magnetic refrigeration: an eco-friendly technology for the refrigeration at room temperature](#)  
C Aprea, A Greco, A Maiorino *et al.*
- [Design of a 300 keV sector cyclotron with external injection](#)  
V A Gladishev, L N Katsaurov, A N Kuznetsov *et al.*

# A small scale remote cooling system for a superconducting cyclotron magnet

**F. Haug, D. Berkowitz Zamorra<sup>1</sup>, M. Michels<sup>1</sup>, R. Gomez Bosch, J. Schmid, A. Striebel, A. Krueger, M. Diez, M. Jakob, M. Keh, W. Herberger, D. Oesterle**

*CERN, Geneva, Switzerland*

<sup>1</sup> *also Karlsruhe Institute of Technology, Karlsruhe, Germany*

Friedrich.Haug@cern.ch

**Abstract.** Through a technology transfer program CERN is involved in the R&D of a compact superconducting cyclotron for future clinical radioisotope production, a project led by the Spanish research institute CIEMAT. For the remote cooling of the LTc superconducting magnet operating at 4.5 K, CERN has designed a small scale refrigeration system, the Cryogenic Supply System (CSS). This refrigeration system consists of a commercial two-stage 1.5 W @ 4.2 K GM cryocooler and a separate forced flow circuit. The forced flow circuit extracts the cooling power of the first and the second stage cold tips, respectively. Both units are installed in a common vacuum vessel and, at the final configuration, a low loss transfer line will provide the link to the magnet cryostat for the cooling of the thermal shield with helium at 40 K and the two superconducting coils with two-phase helium at 4.5 K. Currently the CSS is in the testing phase at CERN in stand-alone mode without the magnet and the transfer line. We have added a “validation unit” housed in the vacuum vessel of the CSS representing the thermo-hydraulic part of the cyclotron magnet. It is equipped with electrical heaters which allow the simulation of the thermal loads of the magnet cryostat. A cooling power of 1.4 W at 4.5 K and 25 W at the thermal shield temperature level has been measured. The data produced confirm the design principle of the CSS which could be validated.

## 1. Introduction

CERN is the European Organization for Nuclear Research. Its complex accelerators and detectors require innovative technologies in many areas, among others in the cryogenics engineering. The CERN policy adopted in the last years fosters the transfer of technologies from CERN to external institutions and support collaboration agreements. In 2010 CIEMAT, a National Institute involved in Energy and Technology Research and Development, together with a consortium of several institutes and companies, has launched a research program with the objective to design and build a highly compact SC cyclotron for H- acceleration for the production of single doses of radioisotope tracers for clinical use in Positron Emission Tomography (PET) imaging techniques [1]. This project is called AMIT (Advanced Molecular Imaging Technologies). For the research phase CIEMAT has asked CERN for consultancy, technology transfer and support in certain fields of technologies with cryogenics being the main contribution. The collaboration agreement established between the two laboratories is the basis for a cooperation in the fields of development of the SC cyclotron magnet and related cryogenics. CERN has taken up the responsibility for the R&D of a compact autonomous cryogenic system able to provide remote cooling



of the magnet for the installation at CIEMAT premises for testing and operation of the cyclotron with a particle beam [2]. This R&D phase precedes a future development of a prototype which is beyond the scope of the agreement with CERN. The innovation lies mainly in its final application which is the possibility of installation of the accelerator equipment at the customer site, this for direct use of the produced radioisotopes in form of single patient doses. In this respect also short-lived isotopes, like  $^{11}\text{C}$  being of high clinical interest as radiotracers for PET, can be produced despite small half times of 20 minutes only.

In this paper we first give a brief description of the cyclotron magnet cryostat with its thermal budget and the internal cooling principle. Then the overall lay-out of the cryogenic system with a flow scheme is detailed. The design of the laboratory Cryogenic Supply System (CSS) as stand-alone equipment is explained in which we introduced a mock-up to allow the simulation of the cooling flow and thermal budget of the magnet cryostat. This mock-up “validator” permits the close to real operation and testing of the CSS. The results of our experiments are given with cooling powers reached.

## 2. The superconducting magnet cryostat cooling requirements

The cyclotron magnet comprises of two small scale SC coils in Helmholtz arrangement housed in a compact cryostat which is surrounded by a warm iron yoke providing a 4 T magnetic field. An aperture in the cryostat between the coils allows the insertion of a room temperature RF accelerator vacuum chamber. Both coils are cooled at 4.5 K with two-phase forced flow helium through helical channels along the inner wall of the coil casing. The vapour quality of the exiting flow is such that an isothermal cooling can be maintained throughout the magnet system. Further non-isothermal cooling of the cryostat thermal shield and the one of the interconnection box as well as the HTc current leads is done with a helium gas flow at 40 K. HTc current leads have been chosen to reduce conduction and ohmic losses. To minimize the thermal load to the SC magnet at 4.5 K we also intercept the heat conduction of the magnet suspension rods in the cryostat at thermal shield temperatures.

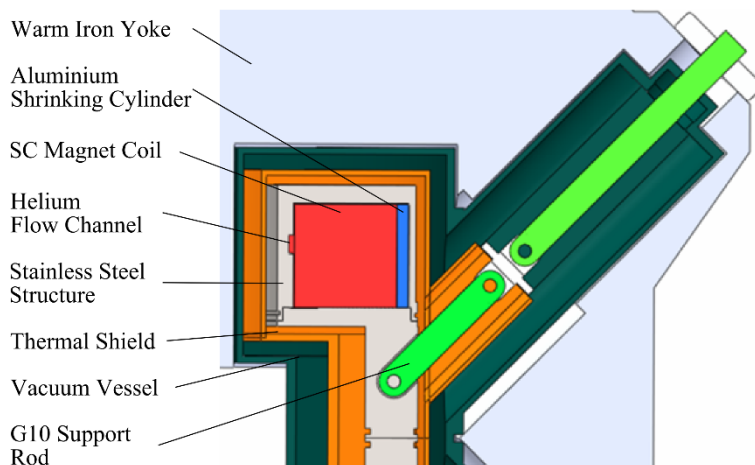

**Figure 1:** Section view of the principle cyclotron design.

## 3. Final Set-up of magnet and cooling system

In the final configuration a specially designed 3.5 m long low-loss transfer line will link the interconnection box of the magnet cryostat to the CSS which provides the cooling capacity for both the 4.5 K and the non-isothermal load. The thermal budgets of the magnet cryostat, interconnection box and transfer line have been estimated based on design criteria applied (**Table 1**).

A simplified picture (**Figure 2**) shows the final arrangement of the main components; the cyclotron comprising the cryostat, SC magnet, iron yoke and the accelerator with RF resonator, the transfer line and the CSS. The CSS consists of a vacuum vessel which contains the commercial cryocooler and a number of heat exchangers with instrumentation and an external circulator system. A detailed description is given in the next chapter. This set-up is expected to be assembled and commissioned at the CIEMAT premises in the second half of 2016. A radiation wall will separate the CSS from the

cyclotron accelerator, while both are linked via the transfer line. This has been a prerequisite to be able to access the cryogenic part for operation and maintenance reasons and to reduce equipment and personnel exposure to potentially harmful ionisation radiation.

**Table 1.** Thermal budget of the Cyclotron System.

	Heat load budget [W]	
	1 <sup>st</sup> stage (40 K)	2 <sup>nd</sup> stage (4.5 K)
Transfer Line	0.83	0.044
Connector Box	2.76	0.412
Current Leads	10.60	0.032
Cyclotron	7.65	0.390
<b>TOTAL</b>	<b>21.84</b>	<b>0.878</b>



**Figure 2.** CAD Model of the final system comprising cyclotron, RF resonator (left) and CSS (right), courtesy of CIEMAT

#### 4. Working principle of the complete system with the CSS cooling unit

A compact helium refrigerator system, based on a GM-cryocooler, was developed to remotely supply helium at two temperatures to the cyclotron client system. An intermediate temperature gaseous helium supply (GHe) at around 40 K, for the cooling of the cyclotron thermal shield and the cooling of the HTc current leads as well as a liquid helium supply (LHe), for the cooling of the superconducting magnets of the cyclotron and the LTc part of the current leads (**Figure 3**).

The refrigerator system can be divided in two parts, a warm part at ambient temperature for the recirculation of the helium, and a vacuum vessel containing the cold head of the GM-cryocooler and the heat exchangers to realize the thermodynamic process of the system. Interconnection to the client system in a closed helium circuit is done with the tailor-made, rigid low-loss transfer line [6].

The warm part comprises a diaphragm pump as main component, which generates a forced helium flow in the circuit. The compression heat is removed from the helium by a water chiller. Via a mass flow controller the helium mass flow can be set. A buffer tank is used to reduce pressure variations due to changing temperatures in the system.

A commercial 2-stage GM-cryocooler type SRDK-415D manufactured by the company Sumitomo was chosen. The two stages of the cold head are called 1<sup>st</sup> (CC1<sup>st</sup>) and 2<sup>nd</sup> (CC2<sup>nd</sup>) stage with the 2<sup>nd</sup> stage being the colder one. A thermal shield is mounted on the 1<sup>st</sup> stage to protect the colder parts of the system against thermal radiation.

There are heat exchangers, E-HX1.x and E-HX2, attached to the two stages to extract the cooling power of the cryocooler which is transmitted to the circulating helium flow. The helium flows are circulated to and from the client system in the specially designed four-pipe low-loss transfer line. The GHe, after being cooled at the extraction heat exchanger (E-HX1.1), is used to cool the HTc current leads (CL-HX1) and the thermal shield of the cyclotron (CT-HX1). Subsequently, after re-entering the refrigerator system via the transfer line, the helium is cooled down again to the previous GHe temperature (E-HX1.2).

The helium is condensed at the extraction heat exchanger (E-HX2) mounted on the 2<sup>nd</sup> stage of the cryocooler coldhead. It is then guided to the two SC coils of the cyclotron and the LT part of the current leads (CL-HX2) for evaporative cooling. The helium is then brought back through the transfer line to the refrigerator system.

To recuperate the remaining cooling power from the returning helium before leaving the vacuum vessel to the pump circuit at ambient temperature, counter flow heat exchangers are integrated into the system (HX1, HX2 and HX3). They serve to precool the helium flow on the go side before being cooled further at the cold head stages.

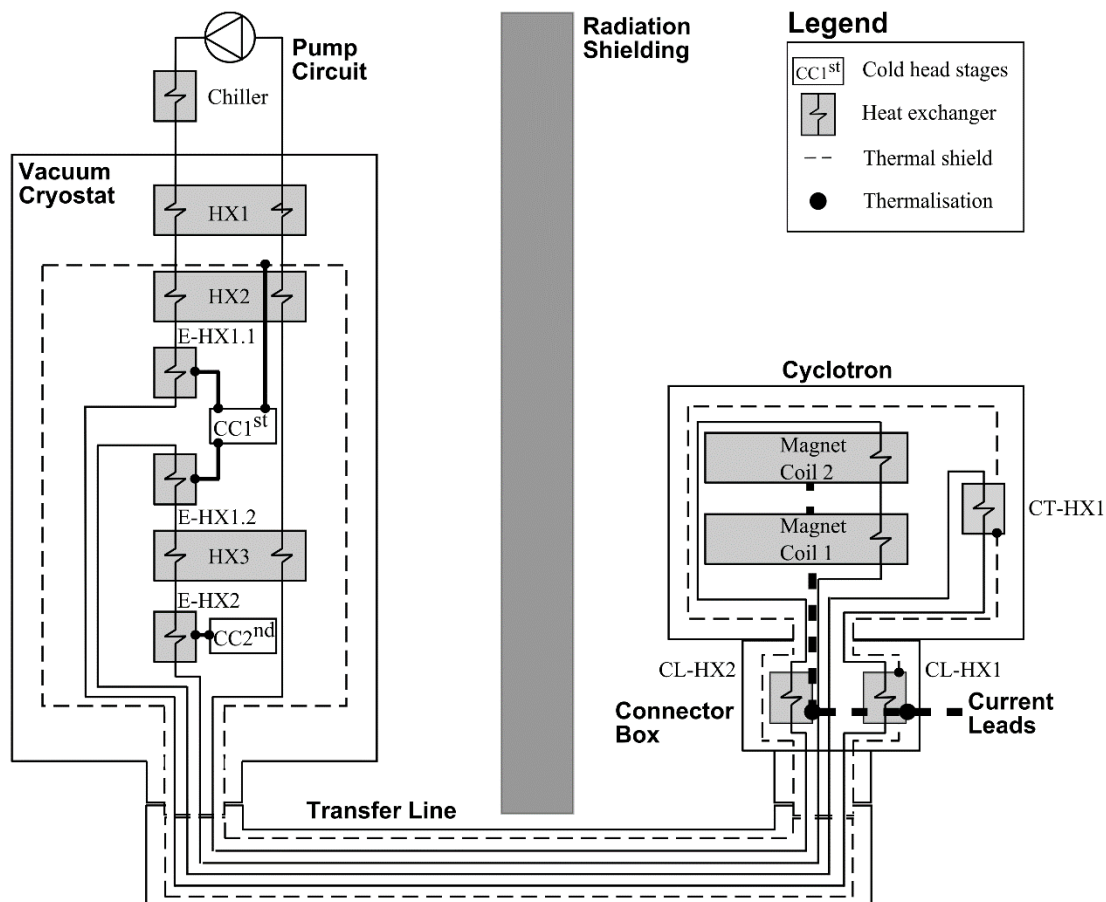

**Figure 3.** Flow diagram of the AMIT cyclotron system comprising CSS, transfer line, connector box, cyclotron and the intermediate radiation shielding.

### 5. Experimental set-up for the validation of the CSS cooling unit

To validate the working principle of the CSS and for its characterization, the CSS is currently being tested at CERN. All cold system components, comprising the cryocooler cold head and all heat exchangers, are suspended from the top flange of the vacuum vessel (**Figure 4**).

The flow diagram is depicted in **Figure 5**. The validation unit consists of three heat exchangers, one at the 40 K level and two to simulate the lower and upper 4.5 K two-phase flow channels of the magnet. For the latter the geometry and hydraulic conditions correspond to the channels of the coils. Three heaters are placed which allow to simulate the respective thermal budget. The tubes foreseen to provide GHe and LHe to the client system via the transfer line, are connected to this so called validators. Hence, the two LHe validators and the GHe validator fully reflect the fluid dynamic design and therefore heat transfer conditions of the cyclotron flow channels.

Temperature sensors are attached to all thermodynamically important locations of the system. The types of sensors were chosen according to the operating temperatures of the CSS at the respective points. For temperatures down to 30K PT100, sensors were specifically calibrated, for lower temperatures CERNOX sensors are used. The distribution of the instrumentation for the validations test of the CSS is shown in **Figure 5** [7]. Special care was taken to thermalise the sensors accurately to the substrate to

provide for precision measurements of the temperatures. Therefore thermalisation stripes are used, which are a further development of the rigid thermometers mounted in the LHC [3]. In addition a concept was elaborated to minimize heat-in leak caused by the instrumentations self-heating and wiring conduction.

The data are automatically measured and stored in a database by a CERN internal, industrial DAQ architecture, the so called ‘crate’ system, specifically developed for the LHC [4][5].

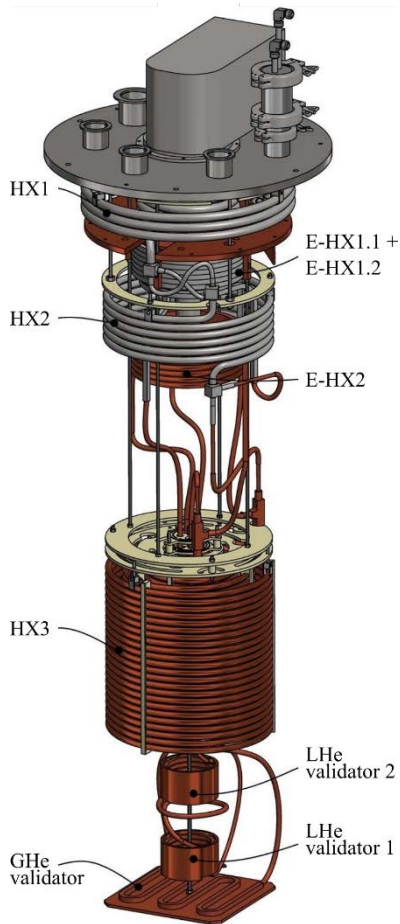

**Figure 4.** CAD model of the CSS insert with attached validators.

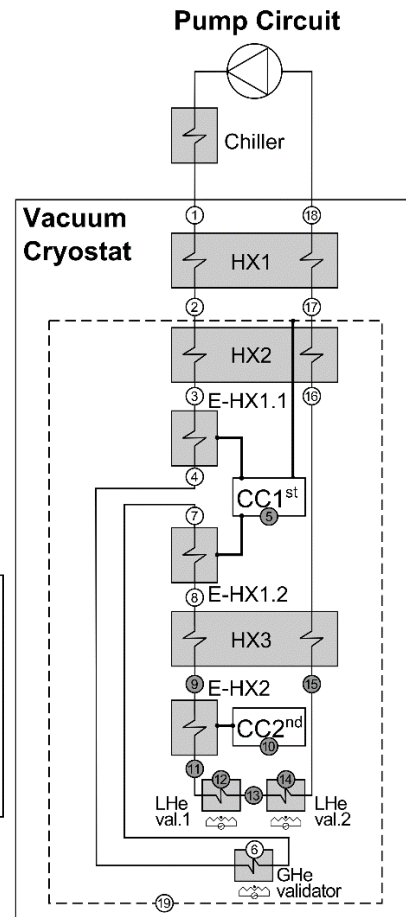

**Figure 5.** Flow diagram of the CSS process with instrumentation. The LHe and GHe validators used for the simulation of the client system are shown at the lower end of the scheme.

## 6. Results of the experiments

The performance of the CSS was characterized at different mass flows and heat loads. The isothermal cooling capacity was determined by introducing the heat power necessary to produce a saturated gaseous helium at the exit of the LHe validator 2. This approach foresees a gradual increase of the heat load applied on the 2<sup>nd</sup> stage for a constant mass flow with the 1<sup>st</sup> stage heat load kept constant.

**Figure 6** indicates that the cooling power provided by the cryocooler  $\dot{Q}_{CC}$  is partially used by the CSS to compensate the static heat loads and thermodynamic process  $\dot{Q}_{CSS}$ , diminishing the supplied cooling power to the client  $\dot{Q}_{Client}$ . To quantify the performance of the CSS, the efficiency  $\eta_{CSS}$  for each helium supply line, non-isothermal GHe and isothermal LHe, is defined as the ratio of the supplied cooling power  $\dot{Q}_{Client}$  to the cryocooler cooling power  $\dot{Q}_{CC}$ .



$$\eta_{CSS} = \frac{\dot{Q}_{Client}}{\dot{Q}_{CC}} \quad (1)$$

The supplied cooling power  $\dot{Q}_{Client}$  corresponds to the heat loads applied to the validators. The cooling power of the cryocooler  $\dot{Q}_{CC}$  can be determined by knowing the temperature of both stages. The mapping of this temperature – power dependency was done previously in a dedicated stand-alone characterization test. It is worth mentioning that the cryocooler stages are at a slightly lower temperature than the corresponding helium stream, due to the temperature difference required for the heat extraction.

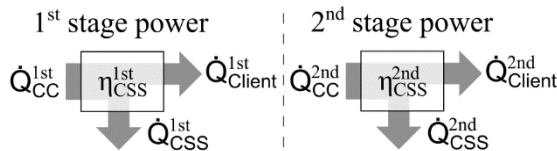

**Figure 6.** The efficiency  $\eta_{CSS}$  for each helium supply line, non-isothermal GHe and isothermal LHe, is defined as the ratio of the supplied cooling power  $\dot{Q}_{Client}$  to the cryocooler cooling power  $\dot{Q}_{CC}$ .

**Figure 7** shows the experimental results at the constant mass flow of 0.08 g/s and a non-isothermal heat load of 25 W at the first stage. The cooling power of the 2<sup>nd</sup> stage, the isothermal helium and the efficiency are shown as a function of the LHe temperature between 4.4 K and 4.55 K. The upper curve represents the cooling performance provided by the cryocooler where 2.2 W can be reached. The second curve is the available remote cooling capacity that the CSS can supply to a “client” with approximately 1.4 W. Below the efficiency is given.

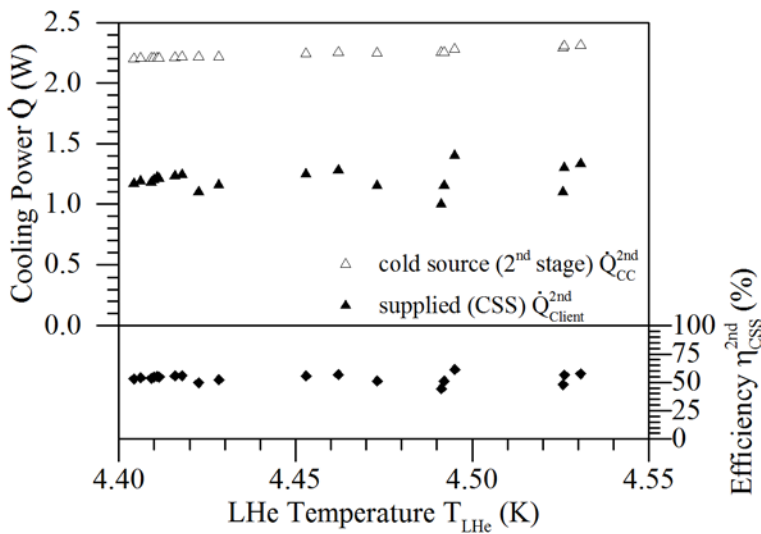

**Figure 7.** Experimental results for the available isothermal LHe cooling power of the CSS vs the LHe temperature, in comparison to the corresponding 2<sup>nd</sup> stage cooling power. Below the resulting efficiency of the process is shown. The data were taken at a constant helium mass flow of 0.08 g/s and a 1<sup>st</sup> stage heat load of 25 W.

At the designed operation point the CSS is able to supply a cooling power of 1.4 W at 4.5 K and 25 W at 40 K, which correspond to an efficiency of  $\eta_{CSS}^{1st}=77\%$  and  $\eta_{CSS}^{2nd} = 61\%$ , respectively.

We further compare the available cooling capacities to the thermal budget of the client system. As can be seen it exceeds the requirements at approximately 50% at 4.5 K (**Figure 8**).

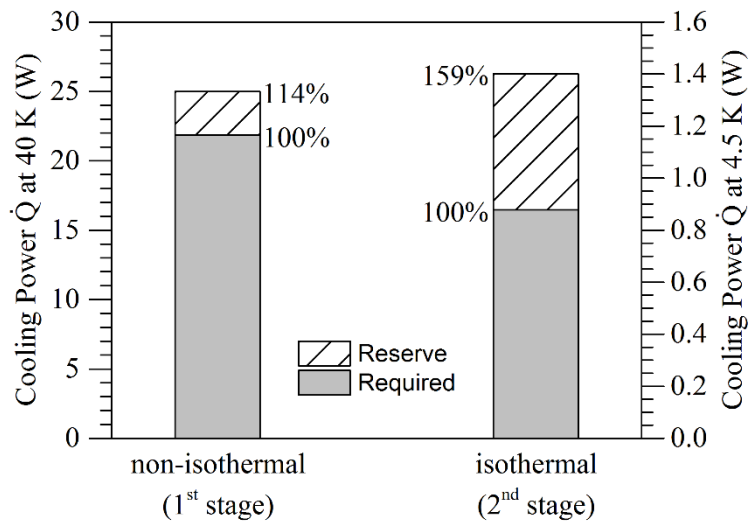

**Figure 8.** Overview of the available cooling power of the CSS on the GHe and LHe supply at the design working point of 4.5 K LHe and 40 K GHe. It is distinguished between the thermal budget of the client system as the cooling requirements and the cooling power reserve of the CSS.

## 7. Conclusions

CERN has constructed a small scale refrigeration system of novel design with a two-stage commercial cryocooler of GM type as the cold source. To the cryocooler a second independent circuit is added which extracts the cooling power with forced flow heat exchangers. An ambient temperature pump circulator provides the forced helium flow. The device permits remote cooling of equipment over a distance of several meters. At baseline, both 4.5 K and 40 K temperature level can be provided, a functionality which makes the system comparable to a standard refrigerator, however, at much smaller scale and cooling power. This Cryogenic Supply System (CSS) was conceived for the cooling of a SC cyclotron magnet at the CIEMAT premises in Spain. To validate the remote cooling principle of the cyclotron, at CERN we introduced a validation unit representing the magnet cryostat thermo-hydraulic circuits. With electrical heaters the remote cooling capacity can be simulated. The maximum capacities reached are 1.4 W @ 4.5 K for the two-phase flow and, 25 W @ 40 K. The principle of the new type of refrigerator CSS has been fully validated and is ready for implementation for its final use to remotely cool the cyclotron magnet.

## 8. Acknowledgments

F. Haug is very much indebted to all co-authors, students he supervised, who conducted in large extend the scientific and engineering part of this work. Thanks are due to the Federal Ministry of Education and Research (BMBF), Germany, for sponsoring 3 years grants of D. Berkowitz Zamorra and M. Michels via the doctoral student program “W. Gentner”, and to the Ministry of Science and Research (MWK) of the Land Baden-Württemberg for the financial support of the internships of J. Schmid, A. Striebel, W. Herberger, A. Krueger, M. Diez, M. Keh, M. Jakob, and D. Oesterle. Acknowledged is the technical contribution of the CERN cryogenics group, in particular the Cryolab and Instrumentation team and the mechanical section, the central workshop and, the support we received from the Technology department and the Finance and Procurement department for this technology transfer oriented work. Last not least we would like to mention the exceptional cooperation spirit with CIEMAT in Spain.

## 9. References

- [1] García-Tabarés L *et al* 2015 Development of a superconducting magnet for a compact cyclotron for radioisotope production *Int. Conf. on Magnet Technology 24* (Seoul, Korea) (submitted)
- [2] Haug F and Berkowitz Zamora D 2014 Closed cycle cryogen recirculation system and method *Int. Patent Application* PCT/EP2015/079195 (priority date 10 DEC 2014, unpublished).
- [3] Balle C and Casas J 1996 Industrial-type cryogenic thermometer with built-in heat interception



*Advances in Cryogenic Engineering* ed P Kittel **41** pp 1715-21

- [4] Casas J, Fernandez G and Rodríguez M A 2008 The radiation tolerant electronics for the LHC cryogenic controls: Basic design and first operational experience *Topical Workshop on Electronics for Particle Physics* (Naxos, Greece) pp195-9
- [5] Casas J and Trikoupis N 2014 Radiation tolerant programmable power supply for the LHC beam screen heaters *Journal of Instrumentation* **9** pp C03024
- [6] Michels M 2014 Entwicklung eines thermisch optimierten Helium Transfer Systems für einen supraleitenden Zyklotron bei 4 K [Development of a thermally optimized helium transfer system for a super-conducting cyclotron at 4K] *Diploma thesis* (Karlsruhe, Germany: Karlsruhe Institute of Technology)
- [7] Jakob M 2015 Instrumentation and measurement of a compact cryogenic refrigeration system *Bachelor thesis* (Esslingen, Germany: University of Applied Sciences Esslingen)