

W4835

## Higher Order Mode Dampers for the KAON Booster Cavity

Amiya Kumar Mitra  
TRIUMF

4004 Wesbrook Mall, Vancouver, BC, Canada V6T 2A3.

### Abstract

A prototype higher order mode (HOM) damper cavity has been designed and tested on a ferrite tuned booster cavity proposed for the KAON factory at TRIUMF. The damper cavity has been designed to keep the overall length minimum and has been optimized by using SUPERFISH code. Low level signal measurements of unloaded and loaded Q of the booster cavity without and with the damper cavity respectively have been reported and it has been demonstrated that nearly all modes up to 1 GHz which couple to the accelerating gap are damped by the mode damper. In order to reduce the coupling at the booster fundamental frequencies by this type of damper, a new concept of damping higher order modes in the KAON booster cavity by employing a high-pass filter is presented. Conceptual design, prototype realization of such a filter in coaxial form and measurements of damping are outlined. Preliminary measurements show that the higher order modes up to 900 MHz are damped significantly with very little power absorption at the fundamental frequencies.

### I. INTRODUCTION

The ferrite tuned booster cavity for the proposed KAON project at TRIUMF operates from 46 MHz to 61 MHz [1]. Higher order modes (HOM) are inherently present in these structures and if not suppressed adequately can cause beam instabilities. The cavity HOMs must be damped substantially to reduce their shunt impedances to acceptably low values. Since the cavity operates over a broad range of frequencies, externally applied tuned dampers may be difficult to implement. For a broad bandwidth it is more effective to install the dampers inside the cavity. A reentrant cavity damper [2], [3] and [4] and a coaxial high-pass filter as a damper [5] are discussed in this paper.

### II. DESIGN OF HOM DAMPERS

The design goal of HOM dampers is to attenuate all the higher order modes up to 1 GHz without affecting the shunt impedance of the cavity at the operating frequency.

#### A. Reentrant Cavity Damper

A reentrant  $\lambda/4$  cavity with heavily loaded tip capacitance, as shown in figure 1, is appended at the gap of the booster cavity. Four 50 ohms terminating resistors are connected to the annular ring of the damper cavity and are placed

symmetrically around the perimeter. As long as the damper cavity provides a high shunt impedance for the higher order modes, the damping is in effect since most of the currents produced by the HOMs will flow through the gap capacitance to the terminating resistors. The damper becomes ineffective at the frequency for which it produces a voltage null at the terminating resistor. This frequency is the series resonant frequency, most commonly known as  $\lambda/2$  mode and should be as high as possible. The dimensions of the damper cavity were optimized by using SUPERFISH. The  $\lambda/4$  resonant frequency mode (high shunt impedance of the reentrant cavity) was chosen to be 185 MHz and the series resonant frequency to be 1570 MHz. This leads to a broad bandwidth of the damper cavity. Decreasing the  $\lambda/4$  frequency below 185 MHz would increase damping of the first HOM of the booster fundamental frequencies but would couple more power at the fundamental frequencies.

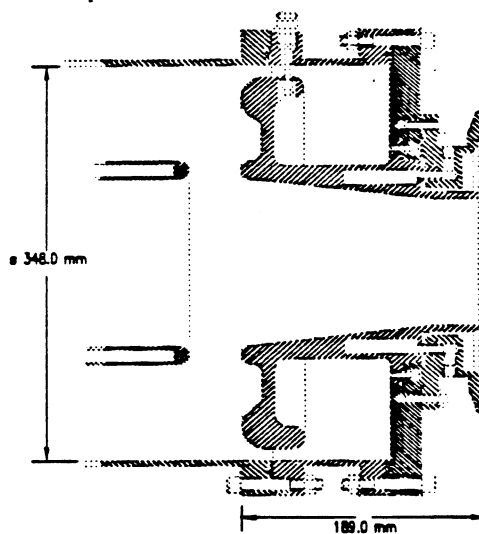

Figure 1. Reentrant damper cavity.

When the damper cavity was connected to the booster, the coupling of the two cavities lowered the  $\lambda/4$  frequency to 161.97 MHz compared to the computed value of 169.726 MHz.

#### B. High pass filter Damper

A new concept of HOM damper in the form of a coaxial high pass filter is connected at the gap of the cavity. If the cut-off frequency of the filter is chosen to provide no attenuation into the terminating load for the currents produced by the HOMs and provide adequate attenuation for the currents at the

fundamental frequencies, then such a filter would be ideally appropriate as a HOM damper.

A five element 0.1 dB ripple Chebyshev high-pass filter would provide more than 40 dB attenuation at the highest fundamental booster frequency of 61 MHz if the high-pass cutoff frequency of the filter is chosen to be 150 MHz. Since the design aim is to damp all the HOMs up to 1 GHz, the passband must be at least 1 GHz. This leads to the following filter specifications.

- High-pass cutoff frequency 150 MHz.
- Maximum passband frequency 1 GHz.
- Minimum attenuation at 61 MHz 40 dB.
- Maximum passband ripple 1 dB .
- Source impedance less than 1 ohm.
- Load impedance 50 ohms.

The high-pass Chebyshev filter which satisfies the above requirements is shown in figure 2 with the corresponding element values.

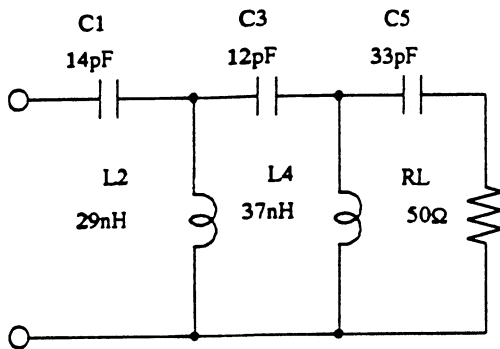

Figure 2. Schematic of the high-pass filter.

The challenge here is to realize these values in a coaxial structure rather than lumped elements. The capacitance's C3 and C5 can be formed out of coaxial rings or discs and the inductors L2 and L4 are provided by hollow rods connected from the short-circuit plate to the respective capacitors. Four terminating resistors are connected to C5 via low inductive connections. The capacitance C1 of 14 pF is the capacitance of the open end of the cavity to the first ring or the disc of the filter. Figure 3 and figure 4 show conceptual model of the ring and disc type coaxial high pass filters. Although prototype of both the filter structures have been made, the disc type is found to be more suitable for the particular application and fabrication tolerances can be relaxed.

### III. MEASUREMENTS OF THE DAMPERS

All the measurements are done with a Network Analyser at a signal level of 20 dBm with two loosely coupled capacitor probes in the cavity. The reentrant damper cavity was tested

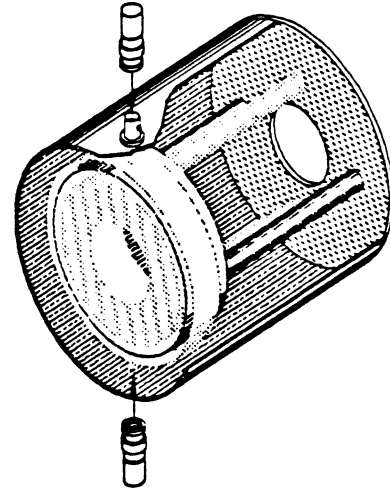

Figure 3. Isometric view of the ring type filter.

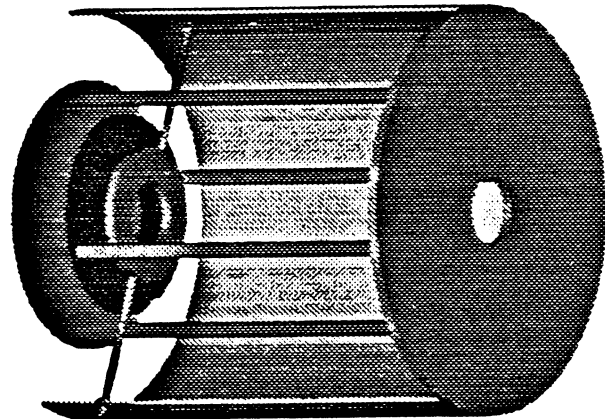

Figure 4. Isometric view of the disc type filter.

on the booster cavity whereas the high-pass filter damper was tested on a 6 inch quarter wave transmission line cavity. The 50 Ω resistors are connected or disconnected for loaded and unloaded Q measurements.

#### A. Reentrant Cavity

Different combinations of termination are tried and Qs are measured for all the resonances in the 10 to 1000 MHz spectrum with a dc bias current of 964 Amps on the ferrite of the booster cavity. Measured unloaded and loaded Q for some of the frequencies are listed in Table 1. It should be noted that with four 50 Ω resistors most of the HOMs are absorbed adequately however the Q at the fundamental frequency is lowered by 22 %. Loss of Q is more pronounced at higher booster frequency (40 % at 57.33 MHz).

Table 1  
Unloaded and Loaded Q Measurements

Frequency	Designation	Unloaded	One Load	Four Loads
f/MHz		$Q_0$	$Q_1$	$Q_1$
52.075	Fundamental	2782	2680	2173
148.097	3 rd harm.	1720	■ 35	■ 10
157.715	Damper $\lambda/4$	1000	■ 10	■ 10
229.279	5 th harm.	2170	332	100
268.519		500	500	100
304.103	TE01 damper	300	300	■ 20
346.103	7 th harm.	1200	1100	208
502.391		118	100	■ 50
765.772		272	260	■ 50
867.255		500	480	■ 50

### B. High pass filter damper

The characteristic of the high-pass filter was measured before it was mounted to the 6 inch cavity. With four 50  $\Omega$  resistors, the cut-off frequency was measured to be 150 MHz with a passband ripple of  $\pm 1.5$  dB and an attenuation of 50 dB at 50 MHz. A peak was observed at 187.9 MHz which was 3 dB above the passband ripple. This is due to the fact the element values of the constructed filter was different from the values of Figure 3. Figure 5 shows the undamped and damped response of the cavity and the filter from 1 to 1000 MHz. Quality factor for all the HOMs up to 500 MHz was reduced by a factor of 100 or more and for the HOMs lying between 500 MHz and 1 GHz, Q was reduced by at least a factor of 10. The shunt impedance for all the HOMs was below 1 k ohms.. Only 1 % of Q at the fundamental frequency is lost due to the filter . The filter has also been tested for broad band operation by varying the cavity frequency without altering any filter parameters .The results show desired broad band characteristic of the filter.

### IV. CONCLUSIONS

The reentrant cavity damps all the HOMs effectively however the power loss ( loss of Q) at the fundamental frequency is very high . On the other hand the high-pass filter damper may lower the Q at the highest booster operating frequency to a maximum value of 5%. This new type of higher order mode damper employing a high pass filter in a coaxial structure is unique and couples very little power at the operating frequency. The final version of the filter is now being fabricated to operate at a gap voltage of 60 kV for the ferrite tuned booster cavity. This filter can also be used for a cavity operating at a single frequency. The practical limit of such a coaxial filter is about 1 GHz.

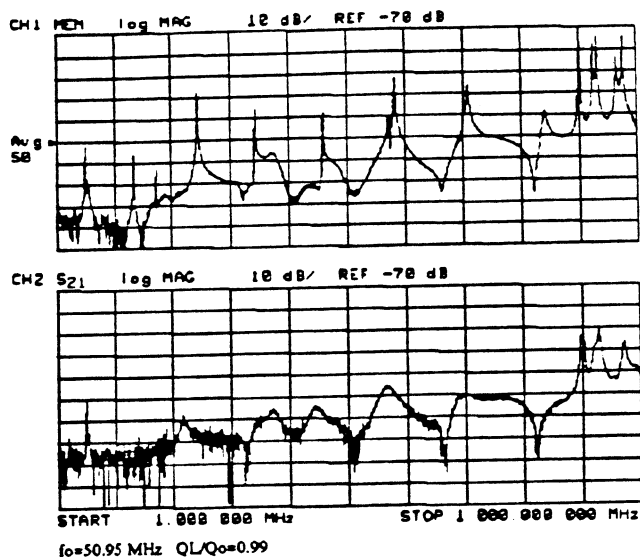

Figure 5. Undamped and damped response of the high-pass filter damper and the cavity.

### V. ACKNOWLEDGMENTS

The author wishes to thank Roger Poirier for many stimulating discussions on the dampers and Peter Harmer for fabrication of the damper cavities.

### VI. REFERENCES

- [1] R. L. Poirier, T. A. Enegren and I. Enchevich, "AC bias operation of the perpendicular biased ferrite tuned cavity for the TRIUMF KAON factory booster synchrotron," Conference Record of the 1991 IEEE Particle Accelerator Conference, Vol. 5, pp. 2943-2945.
- [2] W. R. Smythe, T. A. Enegren and R. L. Poirier, "A versatile rf cavity mode damper," Proceedings of the 2nd European Particle Accelerator Conference, Vol. 1, pp. 976-978 (1990).
- [3] W. R. Smythe, C. Fredrichs and L. S. Walling, "Proton synchrotron rf cavity mode damper tests," Conference Record of the 1991 IEEE Particle Accelerator Conference, Vol. 1, pp. 643-645.
- [4] A. K. Mitra, "A prototype HOM damper cavity for KAON booster," TRIUMF KAON factory project definition study , Design Note TRI-DN-92-K219.
- [5] A. K. Mitra, "Realizing a new concept of HOM damper using a high-pass filter," TRIUMF KAON factory project definition study, Design Note TRI-DN-92-K218.

CERN LIBRARIES, GENEVA



CM-P00068381