

LHC CRYOGENICS – RUN2 (2015) SUMMARY AND PERSPECTIVES

K. Brodzinski, S. Claudet, D. Delikaris, L. Delprat, G. Ferlin, E. Rogez and L. Tavian,
CERN, Geneva, Switzerland

Abstract

After LS1 the LHC cryogenic installation was progressively restarted from May 2014. Cool down, multiple tests and qualifications of the machine components lasts for 10 months. The LHC cryogenic system with new validated scenario came back to operation for period of Run2 on 5th April 2015.

Run2 (2015) is considered as a successful year. The global availability indicated by Cryo Maintain (CM) interlock reached level of 92.1%. Helium yearly consumption was again decreased. Consolidations and repairs applied on different systems of the cryogenic installation were effective.

Main difficulty during last year operation was related to heat load coming from activated electron cloud. In some cases related heat deposition on the beam screen circuit was nearly twice higher than values assumed for the LHC design and cryogenic system was pushed to the limits of its capacity.

Last year operation period was affected with one major failure on 4.5 K cryogenic refrigerator at P8 and a few other small failures linked mainly to operational usage of different components. The spares strategy for critical parts allowed for transparent to operation replacement of these components.

The proposed operation scenario for Run2 (2016) is similar to one used in 2015 with potential for optimisation on P18/P2 cryogenic plants.

INTRODUCTION

The cryogenic infrastructure built around LHC ring is composed of 8 cryogenic plants supplying 8 related LHC sectors. Thanks to different intersection piping, various operation scenarios can be set for operation depending on availability of the cryogenic equipment (e.g. because of failure reasons) or optimizing for energy consumption [1, 2]. Each operation scenario is validated with several tests before admittance for operation with physics. Figure 1 presents two operation scenarios applied for Run1 and Run2 (2015).

The LHC Run1, with beam parameters lower than nominal, allowed for LHC operation with disabled cryoplants A at P6 and P8 (see Fig.1). The cooling power for both related sectors was provided by plant B. This configuration allowed for electrical power savings over 3 years of operation between 10% and 20% with relation to the installed power [2].

Run2 (2015) operation scenario was put in place in order to optimize for availability of rotating machines. Thanks to lower than assumed for design heat load at 1.9 K combined with built-in capacity margin on cold

compressors, three 1.8 K pumping units could be stopped and kept as hot spares in case of failures.

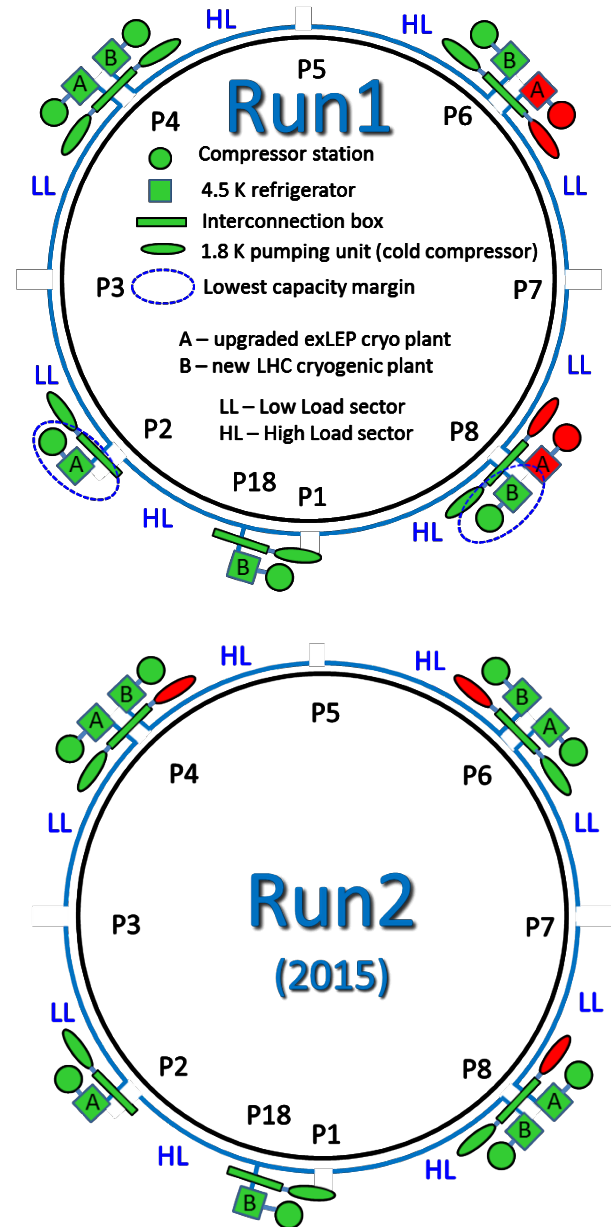

Figure 1: LHC cryogenic operation scenarios.

HARDWARE IMPROVEMENTS IN OPERATION SCENARIO

Although Run2 (2015) scenario allowed for gaining availability, further study of improvements are considered. Currently one cold compressor is pumping on 2 sectors connected to the same cryo-plant.

As such configuration was not foreseen by the design, three valves which should serve for cold bypass between two pumping lines are not sufficiently precise to cope with related regulation and must be consolidated. In this situation cold bypass cannot be used and helium inventory is equilibrated between the cryo-plants at warm level (see Fig. 2). This situation creates capacity unbalance in process between two cryo-plants. After detailed study, it is foreseen to install first prototype of new valves during EYETS and if satisfactory, propagate the final solution during LS2. The solution of cold bypass will allow for improvement of operational stability and performance of the cryogenic system.

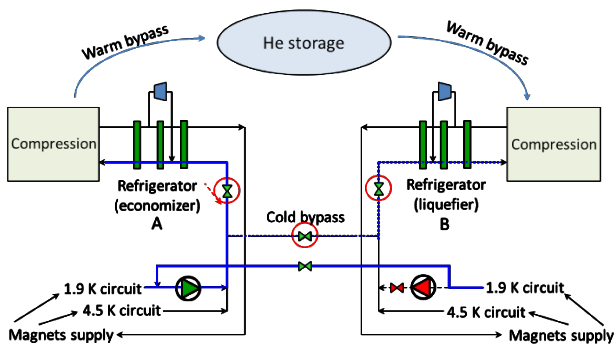

Figure 2: Cryogenic plant configuration with one active 1.8 K pumping unit (2 sectors pumping).

MAIN FAILURES AND OPERATIONAL DIFFICULTIES

During TS1 in June a leak of a mbar/s level has been declared on Turbines 8/9 circuit in QSRB refrigerator at P8. The cold box insulation vacuum pressure raised up degrading seriously capacity of the cold box (see Fig. 3).

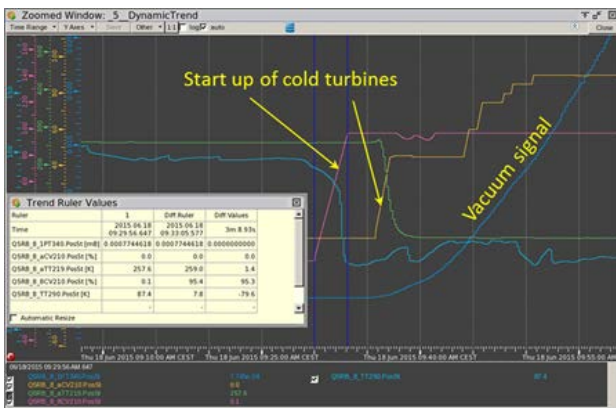

Figure 3: Main failure with vacuum degradation at P8.

By consequence supercritical helium quality in main QRL supply header was degraded affecting visibly cryogenic availability (see section *Downtime analysis*). During remaining part of the year cold box B was set as economizer and cold box A as liquefier to mitigate the failure consequences.

The other components affected by failures and required replacement were following:

- 3 turbines on 4.5 K refrigerators (P18: TU2 and TU3, P2: TU2)
- 1 warm compressor failure (P4: CP6)
- 16 RFL valves installed on AirLiquide turbines
- 4 PLCs

Concerning turbines and compressors, the failure rate is considered acceptable as for usual industrial use, dedicated criticality analysis was done and necessary number of spares is ensured in storage.

The failure rate of RFL valves is elevated therefore dedicated study on progressive replacement of these valves was started in autumn 2015. The First prototypes will be tested during 2016 run and final solution for the valves replacement is foreseen during EYETS or LS2.

PLC upgrade to “anticrash” firmware is underway and will be completed before start of 2016 run.

CRYOGENIC AVAILABILITY

Similarly to LHC Run1, presented cryogenic availability is based on signal from cryo-maintain (CM) interlock and was equal to 92.1 % for 2015 run (from 5th April to 14th December i.e. over 221 days, TSs excluded). The layout and main contributors for downtime are presented in Fig. 4. Comparison with results from Run1 is provided in Fig. 5.

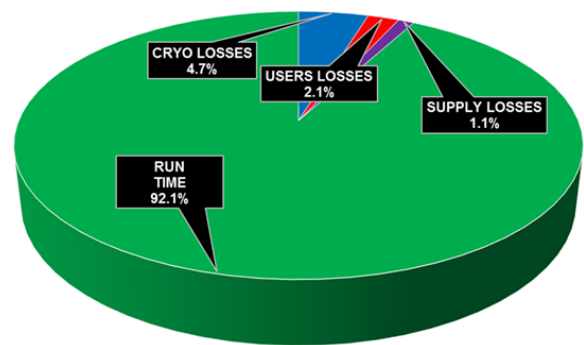

Figure 4: Cryogenic availability for 2015 run basing on CM indicator.

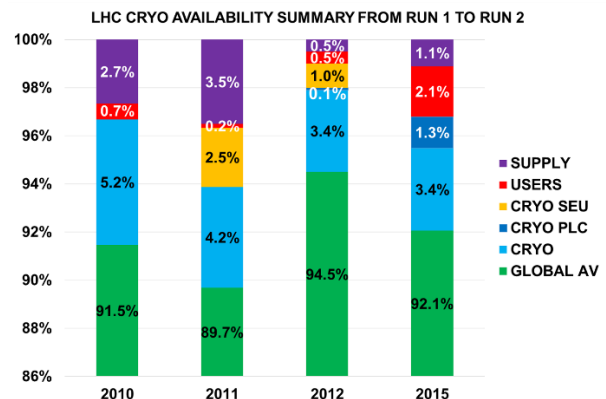

Figure 5: Cryogenic availability for Run1 and Run2.

Downtime analysis

The total time of unavailability for run 2015 was 273h29min caused by 164 losses of CM signal. The most time consuming losses are assigned to 4 top contributors: PLC failures, cold compressor failures, human factor and electrical/instrumentation failures. Mentioned above 4 types of failures covers 75% of total cryogenic downtime (see Fig. 6).

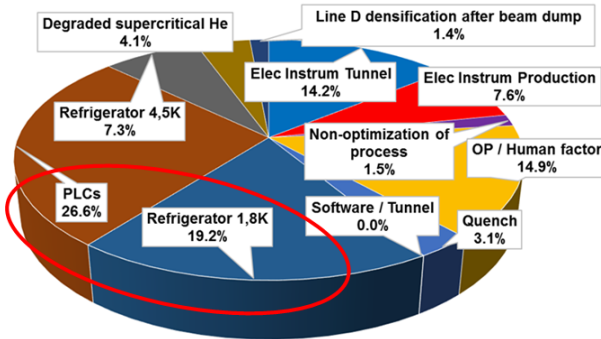

Figure 6: Cryogenic down time – contributors.

The most frequent losses are attributed to DFBs liquid helium level perturbations caused by degraded quality of supercritical helium as consequence of main failure on refrigerator at P8 (frequent losses on DFBMI) and losses of CM signal on DFBAF were liquid helium volume is small and CM limits with its regulation should be revised. The global view of number of CM losses is presented in Fig. 7.

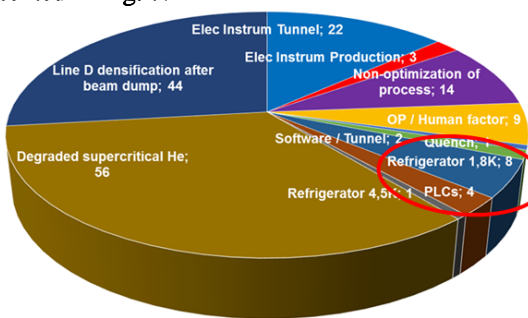

Figure 7: Number of CM losses – contributors.

The cryogenic team focuses to analyse origin and minimize both, most time consuming and most frequent losses.

Cold compressors down time vs operation scenarios

One of the main downtime contributors which unavailability is difficult to be reduced is cold compression system.

Knowing about sufficient capacity margin and in order to minimize downtime, after several tests and analysis, it was decided to stop of some cold pumping units (refer to Fig. 1). As the failure rate does not varied a lot during Run1 and Run2, reduction of operating machines is directly translated in reduction of

number of failures and related downtime. Figure 8 shows results from analysis for 2012 and 2015 with projection to 2016 assuming new operation scenario validated (still to be tested at P18/2).

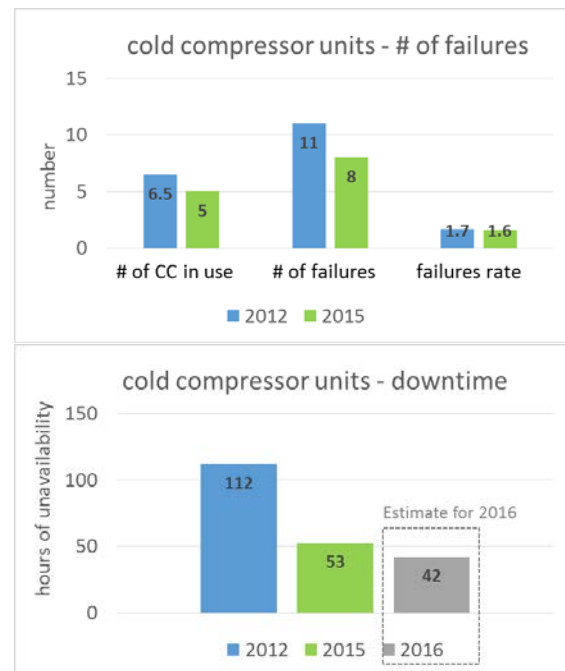

Figure 8: Cold compressor units – availability analysis.

The new proposed operation scenario for 2016 is to stop cold compressor at P18 and operate on sectors 1-2 and 2-3 only with cold compressor unit installed at P2 (see Fig. 9). This operation scenario will be tested during YETS.

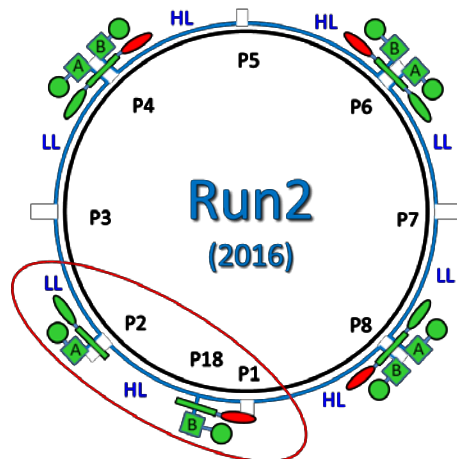

Figure 9: Proposal of operation scenario in 2016.

As cryogenic infrastructure configuration at P18/2 is different from other LHC cryo-islands, such operation scenario is not evident and must be validated. If the test is successful, the benefit from such scenario will be significant: boost of P2 cryo-plant (which is considered as lowest capacity machine – see Fig. 1) and increase in availability if failure rate of cold pumping units does not increase in 2016.

Helium losses

Thanks to collective effort in the cryogenic team during Run1, LS1 and Run2 the helium losses were significantly reduced reaching level of 8.5% for 2015 run. Figure 10 presents evolution of the helium losses for Run1 and Run2.

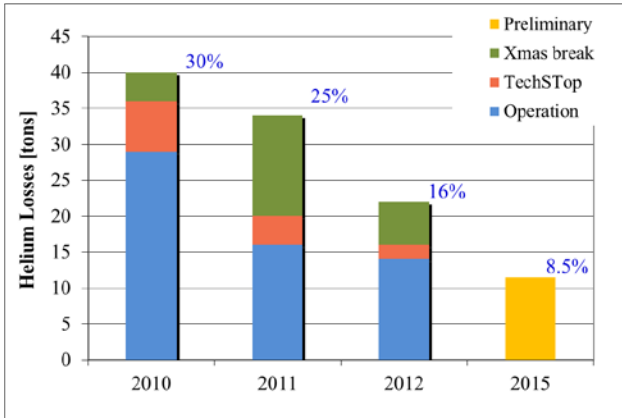

Figure 10: Helium losses evolution.

Feedback from work during LS1

The work during LS1 concerned mainly overhaul of warm compressors, refrigerators repair, DFB and QRL bellows repair, upgrade of beam screen (BS) cooling valves and R2E project. All necessary work activities were done with good benefit for operation. All nonconformities have been treated in the machine. It is worth to mention that zero SEU were declared during 2015 run after LS1 R2E project. Main activities during LS1 are presented visually in Fig. 11.

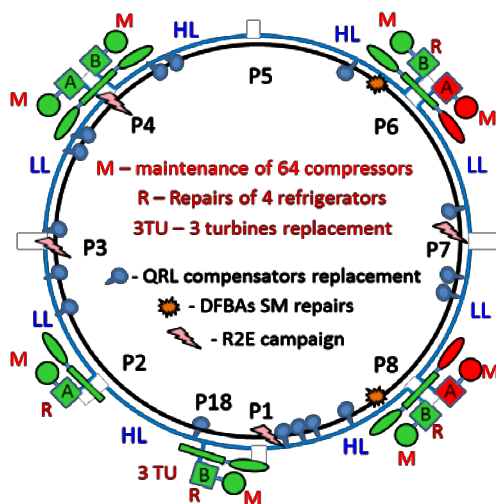

Figure 11: Main activities on cryogenic system during LS1.

MAIN LIMITATION – BEAM SCREEN AND ELECTRON CLOUD

During 25 ns operation heat generated by electron cloud was deposited on the BS circuit pushing cryogenic system up to its capacity limit. This thermal effect required from cryogenics fast dynamic response to compensate for heat load increasing during the beam injection and then large continues requirement for capacity during physics run.

In order to cope with dynamic increase of the capacity in BS loops dedicated feed-forward logic has been developed. It allows for fast increase of the capacity during the beam injection in local cooling loops and avoid excessive increase of temperature in the circuit.

Additionally, prior to injection of the beam, dedicated capacity buffer is prepared in each cold box. Electrical heater in the phase separators are switched on and adjusted at about 1.5 kW to force the cold box to work at high capacity level. While injecting the beam, when feed-forward logic increases the flow in the BS loops, the heaters are automatically ramped down allowing to compensate for dynamic change in global capacity requirements. Then standard cold box capacity regulation is acting on the system.

Design of the system for beam induced heat load and observation during operation

According to LHC design report [1] the beam induce heat load at nominal operation parameters should be equal to 1580 mW/m (85 W/hcell). Installed capacity to compensate for the heat load is 116 W/hcell for both A and B cryo-plants. As the heat load at 1.9 K level is lower than expected, a part of this savings on the cold box capacity can be transferred for BS refrigeration and real limit for BS cooling can be increased to level of 160 W/hcell except sector 2-3 where the limit is at 135 W/hcell (this anomaly of lower limitation at P2 is to be studied, capacity limit of cold box A at P8 is not evaluated since the cold box was working as liquefier during 2015 – to be checked and optimized during 2016 run).

Fact of non homogenous distribution of the heat load over the sectors is not understood and gives additional difficulty to handle the situation. The limiting region for the operation was identified clearly in sector 2-3 with ex-LEP upgraded cryoplant at P2. The heat load and its discrepancy between the sectors in function of the beam intensity is presented in Fig. 12.

Another not understood phenomenon observed during operation is that sectors with high generation of the electron cloud have tendency to clean much slower than sectors with low generation of the cloud (refer to Fig.12).

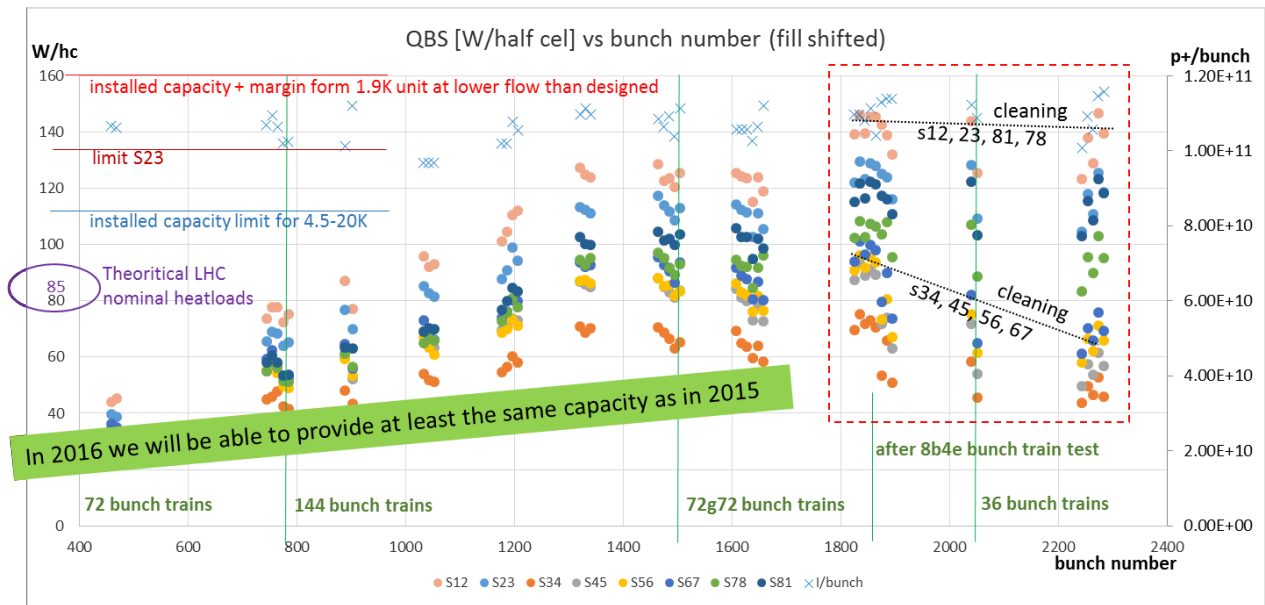

Figure 12: BS heat loads, limits and cleaning behavior.

YETS PREPARATION AND MAIN ACTIVITIES

All LHC LSSs and arcs of s7-8 and s8-1 will be emptied from liquid helium and conditioned at about 30 K. All remaining arcs will be conditioned at 3.5 K with liquid helium.

During year end technical stop (YETS) the following main activities will be performed on the cryogenic system:

- P8 cold box repairs
- PLC upgrade – to be completed
- Replacement of charcoal for oil filtration at P4, P6 and P8
- P4 and P6 ex-LEP installation – preparation for integration of additional coalescers for oil separation.

CONCLUSIONS

The LHC Run2 (2015) is considered as a successful year for cryogenics with availability at 92.1 %. New applied configuration with 3 cold pumping units stopped was a good choice as operation scenario. Feedback from LS1 is very positive, applied consolidations and repairs were accurate and successful. Declared failures could be mitigated by reconfiguration of the system or by repairs using available spare components. New operational scenario with 4 cold compressors stopped for 2016 run must be tested and if successful, applied in operation. The cryogenic capacity will be permanently monitored and optimized for next year operational requirements. Study on the electron cloud and related heat generation is one of the most important subject for 2016 operation.

ACKNOWLEDGMENT

Many thanks to all members of the cryogenic operation and support teams for their engagement and professional approach in 2015 run.

REFERENCES

- [1] O. Bruning et al., "LHC Design Report," Geneva, 2004.
- [2] K. Brodzinski et al. "LHC cryogenics – perspectives for Run2 operation", LHC Beam Operation Workshop – Evian 2014.

