

PAPER • OPEN ACCESS

Cryogenic system configuration for the International Linear Collider (ILC) at mountainous site

To cite this article: H Nakai *et al* 2017 *IOP Conf. Ser.: Mater. Sci. Eng.* **171** 012036

View the [article online](#) for updates and enhancements.

Related content

- [ESS Accelerator Cryoplant Process Design](#)
X L Wang, P Arnold, W Hees *et al.*
- [Adjoint methods for electromagnetic shape optimization of the low-loss cavity for the International Linear Collider](#)
Volkan Akçelik, George Biros, Omar Ghattas *et al.*
- [Simulated Propellant Loading System: Testbed for cryogenic component and control systems research & development](#)
J Toro Medina, J Sass, J Youney *et al.*

Cryogenic system configuration for the International Linear Collider (ILC) at mountainous site

H Nakai¹, T Okamura¹, D Delikaris², T Peterson³ and A Yamamoto¹

¹ High Energy Accelerator Research Organization (KEK), Japan

² European Organization for Nuclear Research, CERN, Switzerland

³ Fermi National Accelerator Laboratory, USA

E-mail: hirotaka.nakai@kek.jp

Abstract. The International Linear Collider (ILC) plans to make use of ten cryoplants for its main linacs, each providing 19 kW at 4.5 K equivalent and among of it 3.6 kW at 2 K. Each cryoplant will consist of various cryogenic components such as a 4.5 K refrigerator cold box, a 2 K refrigerator cold box, and helium compressors and so on. In the technical design report (TDR) of the ILC, due to the mountainous topology, almost all cryogenic components would be installed in underground cryogenic caverns next to the main linac tunnels and only cooling towers on surface area. However, we would like to find a more effective and sophisticated configuration of the cryoplant components (cryogenic configuration). Under several constraints of technical, geographical, and environmental points of view, the cryogenic configuration should be considered carefully to satisfy such various conditions. After discussions on this topic conducted at various workshops and conferences, an updated cryogenic configuration is suggested. The proposed updated configuration may affect the total construction cost of the ILC and the entire structure of the ILC conventional facilities. The updated cryogenic configuration is presented and the on-going discussions with the conventional facilities and siting (CFS) colleagues for further improvement of the cryogenic configuration is introduced.

1. Introduction

The International Linear Collider (ILC) is a superconducting electron-positron linear collider, whose length is about 31 km. The ILC consists mainly of an electron main linac (ML), a positron main linac, damping rings and detectors, as shown in figure 1. The ILC employs various superconducting devices, such as superconducting RF cavities and superconducting magnets. The main linacs consist of many superconducting RF cavities operating at 2 K over the entire length of about 11 km each, and several cryoplants are located along the main linacs to cool down the cavities.

The most possible site of the ILC is expected in a mountainous region in Japan. The helium cryoplants will consist in several cryogenic components such as 2 K and 4.5 K cold boxes, helium compressors, liquid helium storage tanks and so on, as well as the helium cryogenic systems for other superconducting accelerators. The fundamental design and configuration (layout) of the cryoplants in the mountainous site is already described in the technical design report (TDR) published in 2013 [1]. However, it is of importance to continue our effort for a more effective and sophisticated configuration of the cryoplant components, since the circumstances of the ILC has been updated after the TDR.



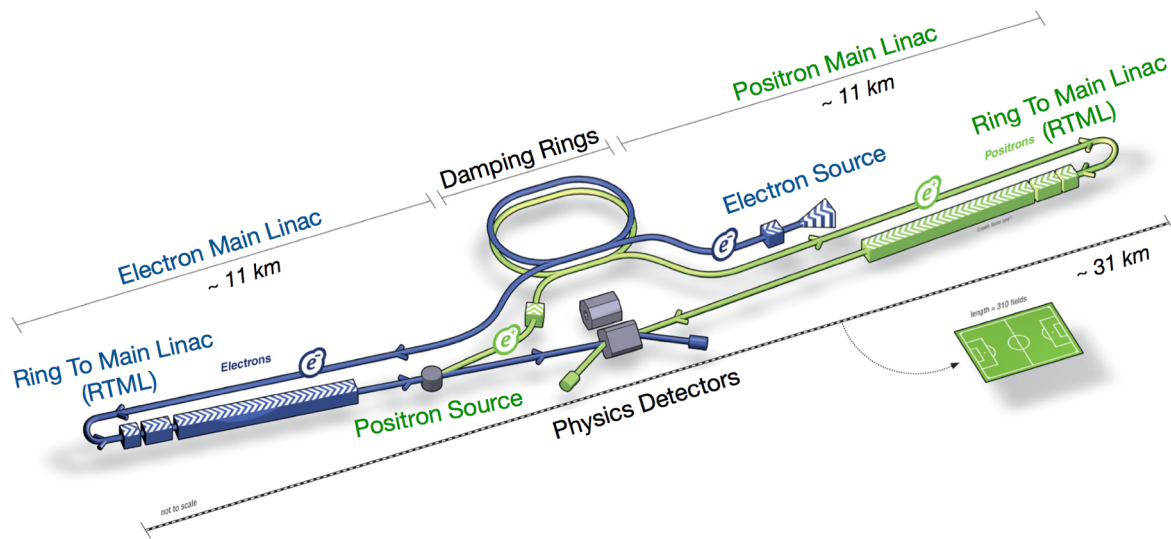

Figure 1. Schematic layout of ILC [1].

Discussions only on the cryogenic configuration of the main linac cryoplants are described in this paper, and an updated cryogenic configuration is suggested after the discussions.

2. ILC Main Linac Cryogenics

2.1. Superconducting RF Cavities

The ILC employs 1.3 GHz 9-cell superconducting RF cavities, made of pure niobium, as shown in figure 2. Since the operation temperature of the superconducting RF cavities is 2 K, a titanium helium tank surrounds the cavity for superfluid helium storage around the cavity, as illustrated in figure 3. Superfluid helium is supplied into the helium tank through the 2-phase helium pipe.

2.2. Cryomodules

Nine or eight superconducting RF cavities with the helium tanks are installed into a cryomodule. The cavities are suspended under a 300 mm gas return pipe, which is fixed to the cryomodule with three support posts. The center support post is rigidly fixed to the vacuum vessel of the cryomodule, while other two can be movable longitudinally for adjusting the shrinkage of the gas return pipe while cooling down from room temperature to 2 K. There are two types of cryomodules. One is designated as “Type A”, which accommodates 9 cavities in it. Another is “Type B”, which does 8 cavities and 1 superconducting quadrupole magnet, as shown in figure 4. The cryomodule has two thermal shields in

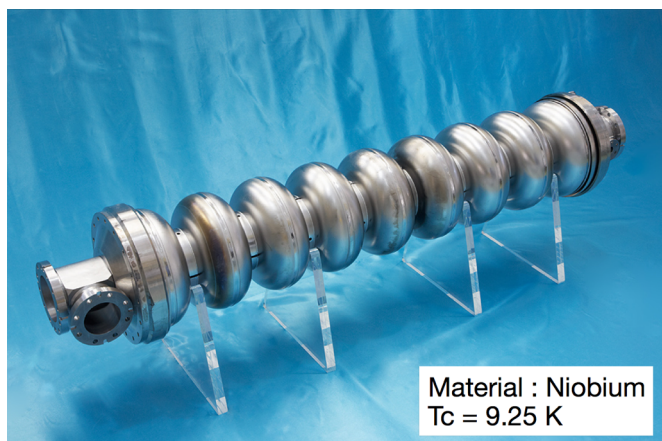

Figure 2. 1.3 GHz 9-cell superconducting RF cavity.

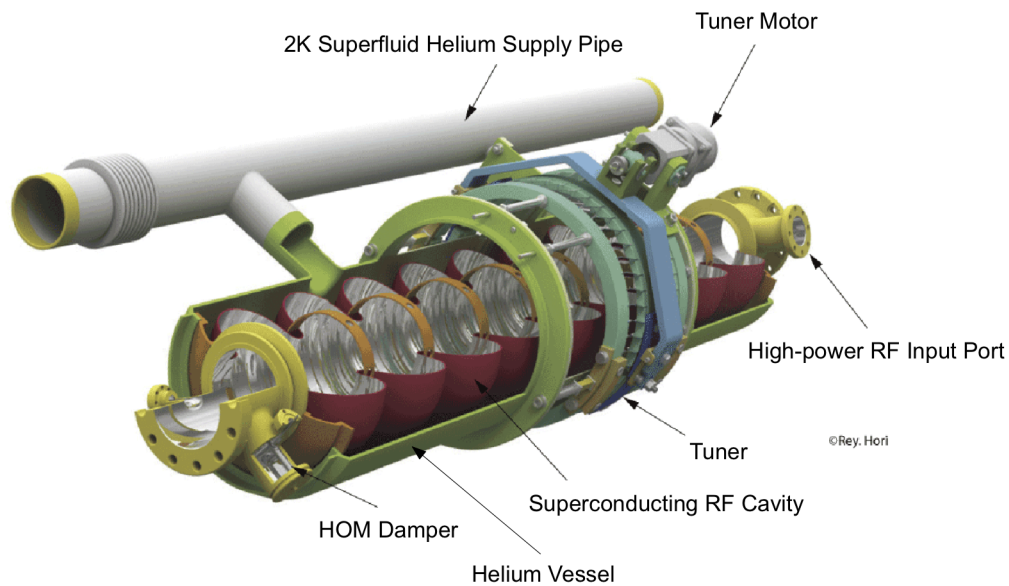

Figure 3. ILC superconducting cavity.

it. Helium-gas-cooled shields intercept thermal radiation and thermal conduction at 5-8 K and at 40-80 K, as shown in figure 5. Through the cryomodules 2.2 K liquid helium is supplied and converted into 2 K superfluid helium through Joule-Thomson valves.

2.3. Cryogenic segmentation

Two Type A and one Type B cryomodules constitute a “main linac unit” (ML unit), which contains 26 superconducting RF cavities in 3 cryomodules. Three ML units and one end box compose a short cryo string, which corresponds to 9 cryomodules or 78 cavities. A long cryo string consists of four ML units and one end box, contains 12 cryomodules or 104 cavities. Included in a cryo unit are 21 or 11 cryo strings. For 21 short cryo strings case, one cryo unit consists of 189 cryomodules or 1638 cavities, and 99 cryomodules or 858 cavities for 11 short cryo strings case. From cryogenic point of view, the cryo string is a basic segment. As shown schematically in figure 6, every cryo string has a Joule-Thomson valve for superfluid helium conversion and a superconducting liquid level sensor.

2.4. Overall layout of ILC cryogenic systems

Figure 7 shows the overall layout of the cryogenic systems in the mountainous site. Ten large 2 K cryoplants, whose cooling capacities are 19 kW at 4.5 K and 3.6 kW at 2 K, will be constructed at 6 access points to the electron and positron main linac tunnels. Some small 2 K and 4.5 K cryoplants will be also constructed at the central region of the ILC for the superconducting RF cavities and the superconducting magnets of the damping rings, the detectors, and so on. In this paper, we focus on the large 2 K cryoplants for the electron and positron main linacs. Roughly speaking, one large cryoplant is employed for one cryo unit. Eight cryoplants refrigerate one cryo unit consisting of 22 cryo strings each. Other two do one cryo unit consisting of 11 cryo strings each. These two take also charge of superconducting cavities at the Ring to Main Linac (RTML) systems. Hence we have to cool down 1701 cryomodules or 14742 superconducting RF cavities in total for the main linacs and 102 cryomodules or 880 cavities in total for the RTMLs at 2 K with 10 cryoplants for the 500 GeV center-of-mass operation.

2.5. Main linac heat loads and cryoplant sizes

The predicted static heat load from a cryomodule is 1.32 W at 2 K, and the dynamic one is 9.79 W at 2 K. Since one cryoplant refrigerates 189 cryomodules, the required cooling capacity of one cryoplant is

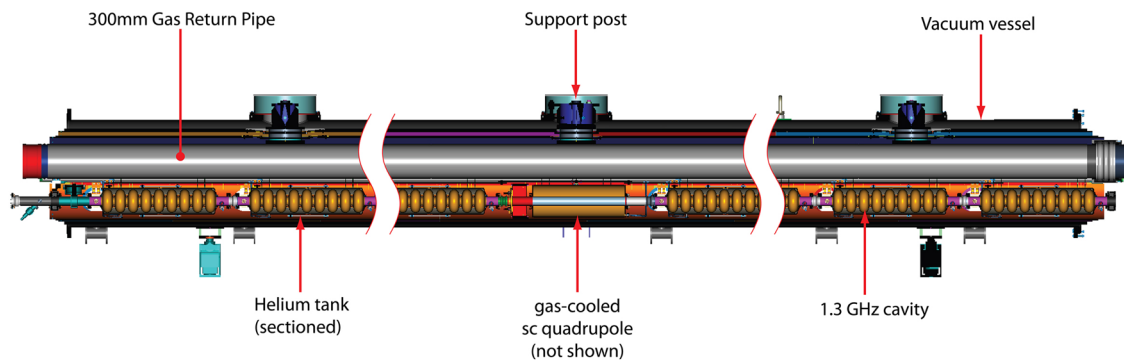

Figure 4. ILC cryomodule (Type B) [1].

estimated to 2.32 kW at 2 K, including some non-cryomodule heat load. If we take 54 % cooling capacity margin under the steady state operation after the initial cool-down, the required cooling capacity of one cryoplant at 2 K is about 3.57 kW. Taking into account the heat loads at 5 K and 40 K, the total installed 4.5 K equivalent power for one cryoplant comes to be 19.01 kW.

3. Discussions on Main Linac Cryogenic Configuration

Major components of a 2 K helium cryogenic system are a 2 K refrigerator cold box, a 4.5 K refrigerator cold box, helium compressors, cooling towers and cryogenic transfer lines. These cryogenic components can be installed on the surface at the access point or in cryogenic caverns underground next to the ML tunnels. There are some constraints to determine the cryoplant configurations at the mountainous site of the ILC, as follows.

- Scenic conservation and environment protection (noise and mechanical vibration)
- Heat removal from helium compressors (cooling towers)
- No liquid nitrogen employed for 4.5 K helium refrigerators and in the underground structures
- Major liquid helium storage tanks (if any) close to 4.5 K helium refrigerators
- Helium storage as gas or as liquid during long-term shutdowns on surface
- Storage of cryogens underground restricted
- Interference of mechanical vibration of helium compressors in ML beam operations to be as small as possible
- Shorter cryogenic transfer lines preferred
- Accessibility for daily checks, cryogen deliveries and accident responses
- Construction costs in good balance with operation costs
- Radioactivation of helium during long-term accelerator operation
- Others

3.1. Environment conservation

At the time when the TDR was drawn up, scenic conservation and environment protection were considered with high priority. Only the cooling towers for cooling water of the helium compressors and liquid nitrogen storage tanks for the regeneration of large charcoal adsorbers of the helium compressors were located on the surface of the mountainous site and all other cryogenic components were in the underground cryogenic caverns next to the ML tunnels, as shown schematically in figure 8. The average depth of the ML tunnels from the mountain surface is about 100 m. The effective distance from an access point to the corresponding cryogenic cavern is about 1 - 2 km. Then in this layout of the cryogenic components, only 1 - 2 km long cooling water pipes are necessary between the helium compressors in the underground cryogenic caverns and the cooling towers on the surface access points.

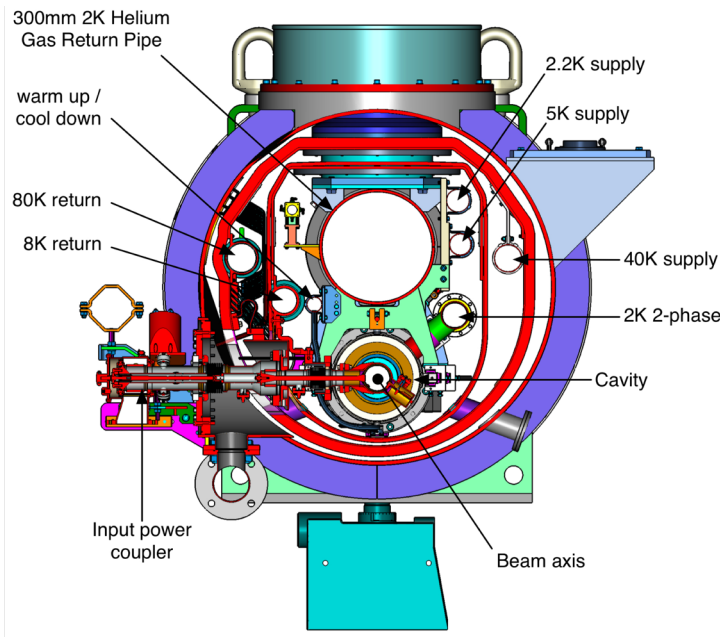

Figure 5. Cross section of ILC cryomodule [1].

The noise levels are restricted by the local government in Japan, depending on time and place. The installation of helium compressors in the underground cavern seems to be reasonable. However, as a result of these considerations, the underground cryogenic caverns should have wider area to accommodate many cryogenic components in them. This means that more construction costs for the underground cryogenic caverns would be required.

3.2. Cryogen storage [2]

The total amount of liquid helium to operate the electron and positron MLs is estimated to 632000 L in the TDR, since one cryomodule may contain 346 L of liquid helium in it. Though the operation of the ILC will be preferred to continue as long as possible without any shutdowns, we have to consider in

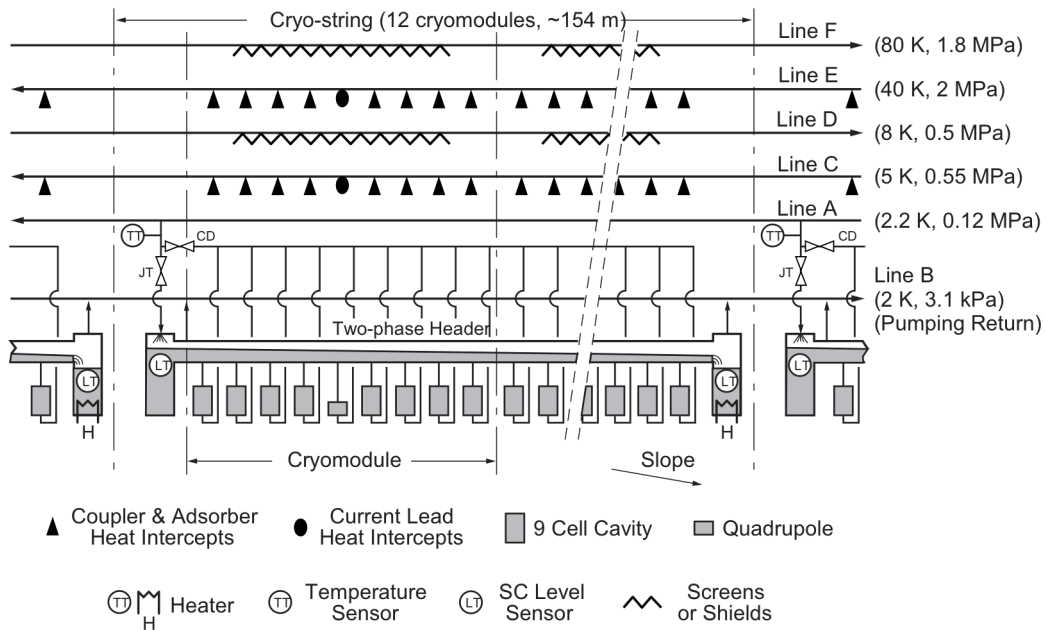

Figure 6. Cooling scheme of long cryo string [1].

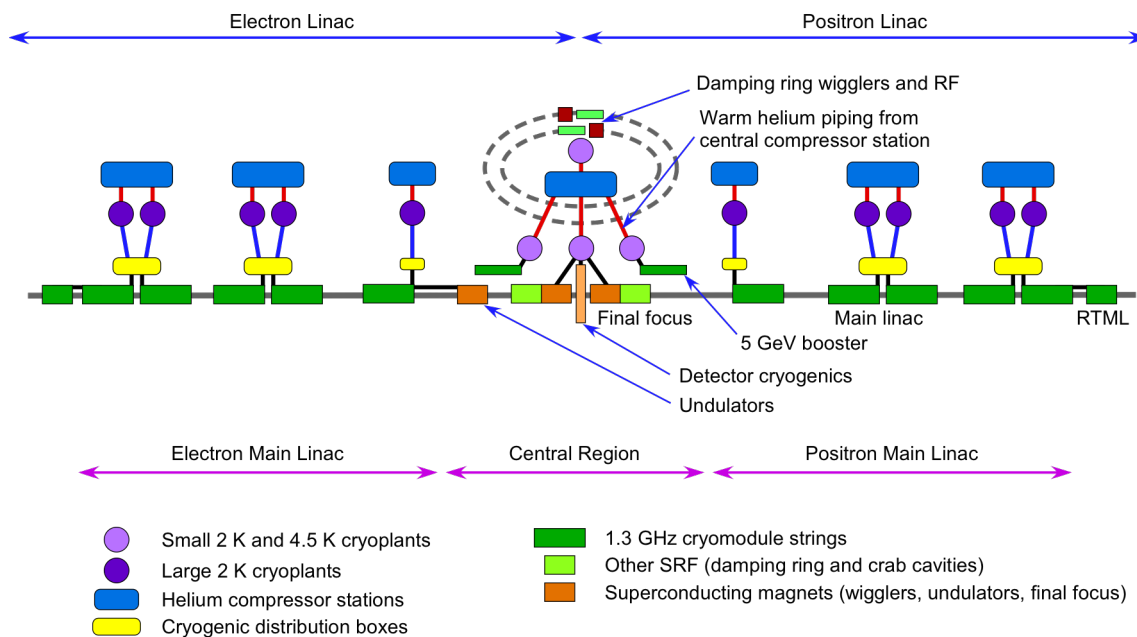

Figure 7. Overall layout of cryogenic systems in mountainous site [1].

advance how we manage such huge amount of liquid helium during long-term shutdowns of the ILC or sudden blackouts. If we consider to store this amount of liquid helium as helium gas in standard gas storage tanks, such as 100 m^3 at 1.8 MPa for example, then we need 250 gas storage tanks to handle the entire helium gas. On the other hand, if we handle as liquid in 50000 L liquid helium storage tanks, it requires 13 liquid helium storage tanks. If 65000 L liquid helium storage tanks are available, we need just to install only one liquid helium storage tank at one cryoplant. However, cryogen storage tanks are strictly controlled to be installed underground in some accelerator institutes in some countries for safety reason. If we choose liquid storage of helium inventory, the liquid helium storage tanks should be installed only on the surface of the access points. Liquid helium evaporates continuously even in a liquid storage tank. We need to re-liquefy the evaporated helium for long-term shutdown. In this case, a small helium liquefier should be prepared (“baby-sitter” liquefier).

3.3. Mechanical vibration of helium compressors

To avoid the interference of mechanical vibration of the helium compressors in the electron/positron beam operation in the MLs, the helium compressors would be installed at the far end of the cryogenic caverns from the ML tunnels in the TDR. It is still uncertain whether the interference of mechanical vibration can be eliminated in the cryogenic caverns. It may be preferred to install the helium compressors on the surface to avoid the interference of the mechanical vibration of the helium compressors in the ML beam operation surely. The helium compressors on the surface may spread out their noises and mechanical vibrations over the calm residence areas. However, noises can be controlled properly, such as HERA/XFEL compressors at DESY. It is important to assess how much noise and vibration can be accepted among the residents, and how the optimum locations for these installations on the surface can be selected with contribution from natural geology and site shape (such as in valley).

3.4. Shorter cryogenic transfer lines

There is no doubt that the 2 K refrigerator cold boxes should be installed in the cryogenic caverns to shorten the 2 K cryogenic transfer lines to the cryomodules in the ML tunnels. It seems to be reasonable that the 4.5 K refrigerator cold boxes are installed next to the 2 K refrigerator cold boxes in

the cryogenic caverns, since the connecting transfer lines can be short, or in some case the 2 K and 4.5 K refrigerator cold boxes can be unified into single compact cold boxes. Since the liquid helium storage tanks should be located on the surface, as mentioned above, the 4.5 K transfer lines should be long up to 2 km, if the 4.5 K refrigerator cold boxes are installed in the cryogenic caverns. On the other hand, if the 4.5 K refrigerator cold boxes are installed on the surface, there should be also long 4.5 K cryogenic transfer lines between the access points on the surface and the underground cryogenic caverns, which connect the 2 K and 4.5 K refrigerator cold boxes. The location of the 4.5 K refrigerator cold boxes remains pending, requiring further study.

3.5. Accessibility

During the operation of the cryoplants, daily checks of the cryogenic system are compulsory under the high pressure gas regulation. Also, whenever any accidents such as technical malfunctions of the cryogenic components occur, the operators of the cryoplants should readily access to the cryoplants as soon as possible to fix or to recover from the accidents. It is clear that the cryogenic components had better to be installed on the surface for quick access in case of accidents. To consider cryogens and gas deliveries from the companies to the cryoplants, the reception ports should be prepared on the surface for easier access. If the ports are located in the cryogenic caverns, cryogen trailer trucks should reach to the cryogenic caverns, and this brings large access tunnels from the surface to the cryogenic caverns should be constructed. Hence liquid helium storage tanks and helium gas tanks should be located on the surface to avoid such situations.

3.6. Construction costs

The total construction cost of the main linac cryoplants depends on the cryogenic configuration. The construction cost of an underground cryogenic cavern may be more expensive than that of a surface area. Hence the more we arrange the cryogenic components in the cryogenic cavern the more the construction costs. On the other hand, cryogenic transfer lines are much more expensive than ordinary water and gas pipes, because of their complex and vacuum-tight design, and many construction steps.

The cryogenic configuration described in the TDR, as shown in figure 8, requires larger underground cryogenic caverns because of many cryogenic components in it, while only the cooling water pipes are necessary between the surface access points and the cryogenic caverns. If many of the cryogenic components will be installed on the surface, the necessary cryogenic caverns can become smaller and the construction costs may be reduced. However, long cryogenic transfer lines should be installed between the surface and the cryogenic caverns. This raises the total construction costs.

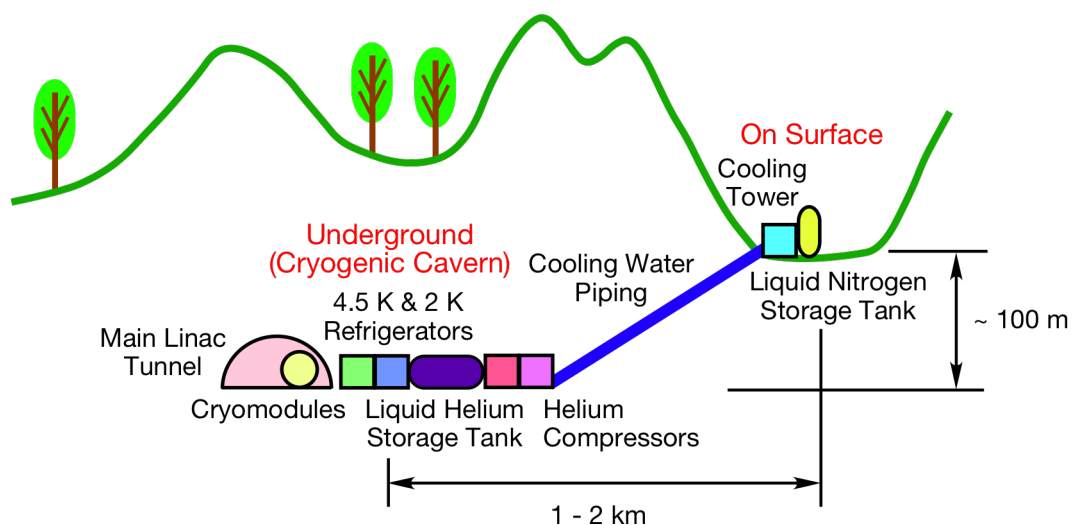

Figure 8. Cryogenic layout in TDR.

3.7. Radioactivation of helium

The radioactivation of helium during the accelerator operation can be much smaller, based on the previous experiences. The radioactivation of helium has been monitored for long time in CERN, Switzerland and Fermi National Accelerator Laboratory, USA, and no stronger radiation has been detected than the regulation level.

Figure 9 is the schematic cryogenic layout currently suggested, in which the 4.5 K refrigerator cold box is assumed to be located in the cryogenic cavern for the present. The locations of the helium compressors, the cryogen storage tanks and the cooling towers can be fixed at the surface of the access points, and that of the 2 K refrigerator cold box in the underground cryogenic cavern. Only the location of the 4.5 K refrigerator cold box is not fixed in the current layout. Depending on the location of the 4.5 K refrigerator cold boxes, the kind of the long piping between the cryogenic cavern and the access points will be determined.

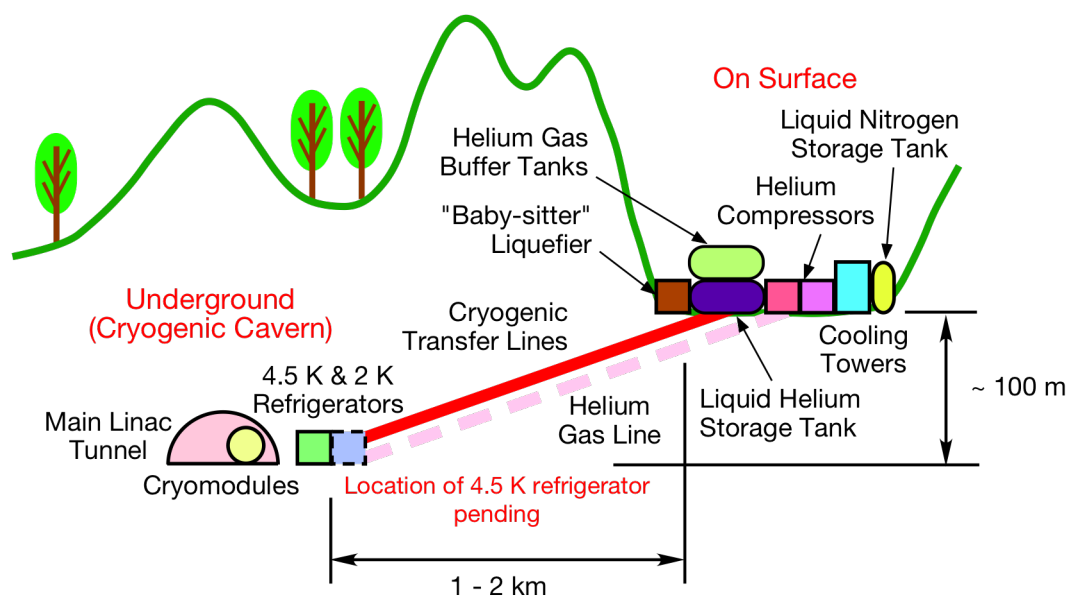

Figure 9. Current cryogenic layout.

4. Summary

The basic design of the ILC cryogenic systems is described in the technical design report published in 2013. Since the most possible site for the ILC is a mountainous region in Japan, the configuration of the ML cryoplants is currently discussed for optimum cryogenic systems.

The location of the cooling towers for the cooling water of the helium compressors has been already fixed on the surface of the access points. The helium compressors and the cryogen storage tanks will be installed on the surface areas, though these were located in the underground cryogenic caverns in the TDR. The location of the 2 K refrigerator cold boxes is in the cryogenic cavern to be connected to the cryomodules in the ML tunnels with shorter cryogenic transfer lines.

Once the Japanese government gives the “green signal” to the ILC, we will start to design the cryoplants in detail with expected manufacturers of the cryoplants.

References

- [1] The International Linear Collider Technical Design Report 2013
www.linearcollider.org/ILC/Publications/Technical-Design-Report
- [2] Hosoyama K Cryogenic cavern in Asian site *International Workshop on Linear Colliders 2010* Geneva, Switzerland, <http://agenda.linearcollider.org/event/4507/other-view?view=standard>