

CRAB CAVITY SYSTEMS FOR FUTURE COLLIDERS*

S. Verdú-Andrés[†], I. Ben-Zvi¹, Q. Wu, Brookhaven National Laboratory, Upton, NY 11973, USA
 R. Calaga, CERN, Geneva 23, CH 1211, Switzerland
¹also at Stony Brook University, Stony Brook, NY 11974, USA

Abstract

KEKB was the first facility to implement the crab crossing technique in 2007, for the interaction of electron and positron beams. The High Luminosity Large Hadron Collider (HL-LHC) project envisages the use of crab cavities for increasing and levelling the luminosity of proton-proton collisions in LHC. Crab cavities have also been proposed and studied for future colliders like CLIC, ILC and eRHIC. This contribution will focus on the near and far future of crab cavities for particle colliders.

MOTIVATION

Head-on collisions are a straightforward way to collide bunches in order to maximize luminosity. However, TeV range linear colliders and high luminosity circular colliders require in most cases a crossing angle, like in Fig. 1.

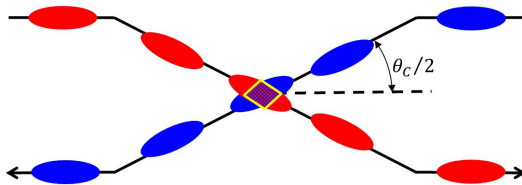

Figure 1: Crossing-angle scheme.

The crossing angle is introduced to mitigate the interaction of debris and particles with detector and instrumentation. In circular colliders, the crossing angle also helps reducing beam-beam effects.

The crossing-angle scheme adapted in some particle colliders may lead to an overall reduction of the luminosity. Neglecting beam-beam effects, the luminosity reduction associated to the crossing angle is given by a simple geometric factor:

$$R_\Phi = \frac{1}{\sqrt{1 + \Phi^2}}.$$

The namely Piwinski angle Φ is defined as:

$$\Phi = \theta_c \sigma_z / 2\sigma_x,$$

where θ_c is the crossing angle, σ_z is the bunch dimension in the longitudinal phase-space and σ_x is the bunch dimension in the transverse phase-space.

* Work partially supported by US DOE via BSA LLC contract No. DE-AC02-98CH10886 and by the US LARP and the HL-LHC programs.

[†] sverdu@bnl.gov

CRAB CROSSING

Crab crossing offers a way to reestablish effective head on collisions. Head and tail of the bunch must receive a transverse momentum kick of the same magnitude but opposite direction. The bunch will wiggle as it advances towards the Interaction Point (IP). In order to maximize luminosity, the imparted kick must be such that the two colliding bunches fully overlap at the IP, as shown in Fig. 2. One or several deflecting RF cavities (from now on called crab cavities) can provide the transverse momentum kick. To provide a crabbing kick, the phase of a deflecting RF cavity must be zero when the bunch is at the cavity center. The kick voltage V_\perp depends on several parameters as follows:

$$V_\perp \simeq \frac{\theta_c E_0 c}{4\pi f R_{12}},$$

where E_0 is the beam energy, c is the speed of light, f is the RF frequency of the deflecting mode and R_{12} is the transfer matrix component between the crab cavity and the IP, given by $R_{12} = \sqrt{\beta_{crab}\beta^*}$. Here β_{crab} and β^* are the betatron function at the crab cavity location and at the IP, respectively.

In the global crabbing system, the bunch continues wiggling around the accelerator after it crossed the IP. In the local crabbing system (represented in Fig. 2), the colliding bunches receive a crabbing kick before arriving to the IP and then receive an un-crabbing kick after leaving the IP. Un-crabbing is not necessary for linacs.

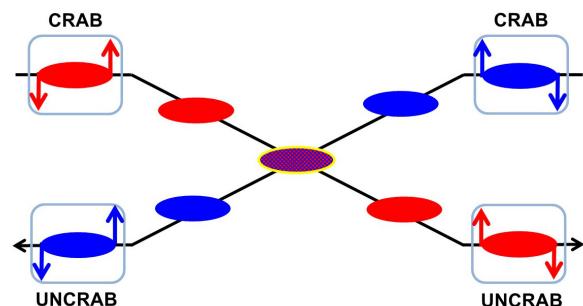

Figure 2: Crab-crossing scheme.

FIRST IMPLEMENTATION

Initially proposed for TeV range linear colliders [1], the crab crossing was firstly implemented for the electron-positron circular collider KEK-B [2]. Beam-beam studies had shown higher luminosity gain resulting from the expected increase of geometric overlap from head on collisions and an increase of the beam-beam tune shift.

The accelerator was equipped with two cavities, one for each beam, for crabbing following the global scheme. The crab cavities were designed to deliver between 0.8 and 1.6 MV. The superconducting squashed elliptical single-cell cavities operated at 4 K providing a crabbing kick at 509 MHz using the TM110 mode. Figure 3 shows the KEKB crab cavity design.

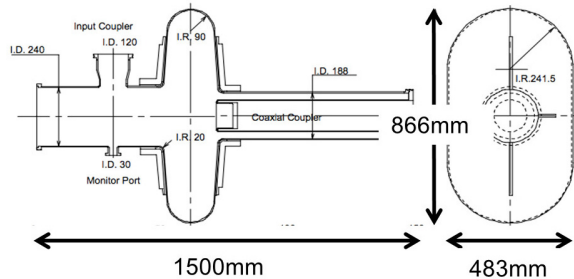

Figure 3: KEKB crab cavity design.

The cavities provided a successful crabbing kick for maximum bunch overlapping at the IP. However, the beam-beam tune shift was not compensated as predicted from simulations. By the time this paper was written, KEK-B was the only accelerator facility where crab cavities had been operated.

Nowadays several particle colliders, linear and circular, include crab cavity systems in their designs. The following section will summarize the crab cavity systems proposed for future colliders.

FUTURE LINEAR COLLIDERS

Linear colliders have one single chance to collide the particle bunches. To maximize luminosity, bunches are greatly focused ($\sigma_z/\sigma_x \gg 1$). However, the presence of the necessary crossing angle makes the bunch collision very inefficient. Adopting the crab-crossing scheme helps restoring the head on collision, thus increasing the luminosity gain. This is the case for the International Linear Collider (ILC) [3] and the Compact Linear International Collider (CLIC) [4]. Both linear colliders include crab cavity systems in their designs.

ILC

The 14 mrad crossing angle in ILC is fully compensated by crabbing both positron and electron beams. The 500 GeV center-of-mass energy design envisages a 474 nm-wide bunch. The bunch is 0.3 mm long [3]. The luminosity reduction factor R_Φ is nearly 22% if crab crossing is not implemented.

The crabbing kick is provided by two 3.9 GHz TM110 π -mode 9-cell cavities per beam. The superconducting cavities are operated at 1.8 K and a 5 MV/m peak deflection [5]. The lower and higher order modes need to be effectively damped, as well as the vertical polarization of the deflecting mode.

Control of the RF phase noise must be within 61 fs between positron and electron crab cavities for optimal

overlapping at the IP. Tests conducted at the Jefferson Lab Energy Recovery Linac facility demonstrated feasibility after controlling the noise at a level of 37 fs for a 7-cell 1.5 GHz prototype [3].

CLIC

The 44 μm -long and 45 nm-wide bunches of CLIC collide with a 20 mrad crossing angle. Such narrow bunches make the crab cavities a critical device to reach high luminosity. Without crab crossing, R_Φ is about 10%.

The crab cavities for CLIC are 11.994 GHz 12-cell Traveling-Wave (TW) constant-impedance structures made of copper. Such frequency is chosen to limit the required deflecting voltage and to match other RF systems in the accelerator. There is one crab cavity per beam. The cavities are designed to provide a deflecting kick of 2.55 MV for the 1.5 TeV energy beams. The racetrack cell-shape allows setting the same order dipole mode frequency at the center of two bunch harmonics. In consequence, every other bunch damps the unwanted mode. Lower and higher order modes will also need to be damped [6].

The high-gradient RF test of a first crab cavity prototype demonstrated stable operation at 43 MW (much higher than the nominal 13.35 MW) with 200 ns-long pulses and a breakdown rate of 10^{-6} breakdowns per pulse.

The control of the synchronization for the two CLIC crab cavities is more severe than for the ILC system. The control over phase and amplitude shall be better than 4.4 fs and 2%, respectively, to limit luminosity loss [7].

FUTURE CIRCULAR COLLIDERS

HL-LHC

One of the upgrades towards the High Luminosity LHC (HL-LHC) consists in increasing the squeezing at the interaction point from 0.55 m to 0.15 m. The crossing angle of the colliding beams will then be increased from 290 mrad to 590 mrad in order to reduce beam-beam effects. To fully benefit from the tightly focused bunches, crab crossing is envisaged for IP1 and IP5. The introduction of a 400 MHz crab cavity system will increase the peak luminosity by 70%.

The crab cavity system of HL-LHC follows the local scheme. The cavity system providing the crabbing and uncrabbing kick for IP1 is based on the Double Quarter Wave (DQW) cavity design, depicted in Fig. 4. The cavity system for IP5 is based on the RF Dipole (RFD) design, illustrated in Fig. 5. Both cavity designs stand out for their compactness, a necessary feature to satisfy the limited space constraints imposed by the second beam pipe of LHC [8]. The superconducting cavities operate at 400.79 MHz in Continuous Wave (CW) mode.

Prototypes of each cavity design were fabricated and successfully cold tested in 2013, exceeding the required deflecting voltage of 3.4 MV per cavity [9, 10]. The cavity designs were then optimized for operation in HL-LHC, with special attention paid to High Order Mode (HOM)

damping and impedance budget, thermal issues and multipacting. Other associated systems like tuning system, helium vessel, HOM filters and cryomodules were designed.



Figure 4: Bare DQW crab cavity for HL-LHC.

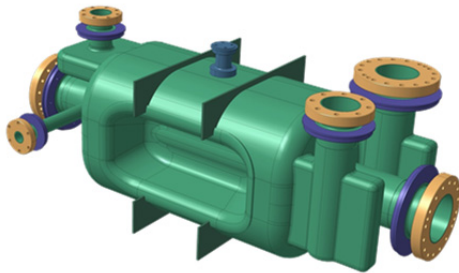

Figure 5: Bare RFD cavity for HL-LHC.

Niowave Inc. fabricated two prototypes of the DQW cavity design and another two of the RFD one. One prototype of each cavity model has successfully been tested at Jefferson Lab, exceeding again the required deflecting voltage per cavity [11].

Two other DQW cavities were fabricated in house at CERN and cold tested in SM18 reaching also voltages above 3.4 MV [12]. The helium vessel has been assembled around one of the cavities and will be cold tested soon with 3 HOM filters. The two DQW cavities fabricated by CERN will be finally fully dressed and inserted into a cryomodule currently under preparation. The cryomodule will be installed in SPS by the end of 2017 and tested with beam in 2018. A cryomodule with two fully equipped RFD cavities will also be prepared for beam tests in SPS. The SPS beam tests will evaluate the issues related with the operation of the crab cavities, including low level RF control, HOM damping and emittance growth, and cryogenic loads.

JLEIC

The most current design of the Jefferson Lab electron Ion Collider (JLEIC) adopts a 50 mrad crossing angle. Crab crossing will be implemented in the two IPs of JLEIC to compensate the crossing angle [13].

The crab cavity system shall operate at 952.6 MHz in CW mode. Three different superconducting cavity options are currently under consideration: squashed elliptical,

RFD and multi-cell cavity [14, 15]. Figure 6 displays the different cavity geometries under consideration.

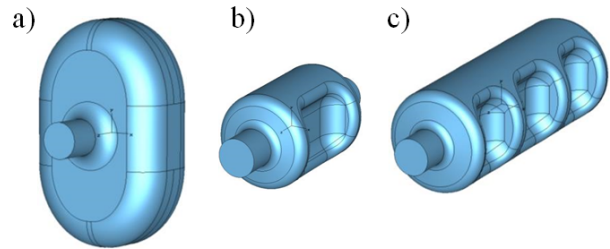

Figure 6: Different cavity geometries considered for the crab cavity system of JLEIC: a) squashed elliptical single-cell; b) RF dipole single-cell and; c) multi-cell RF dipole.

eRHIC

The beams of the electron ion collider eRHIC will collide with a 22 mrad crossing angle. Crab cavities will be incorporated in two IPs to increase luminosity. The crab cavity system will follow the local scheme.

The crab cavity system for the proton beam will operate at 337.8 MHz [16]. A transverse kick of 12 MV is needed to reach a peak luminosity of $4.5 \times 10^{33} \text{ cm}^{-2} \text{ s}^{-1}$ with bunch frequency of 56 MHz. The crab cavity design is currently based on the DQW cavity developed for the HL-LHC crabbing system. The eRHIC crabbing frequency is slightly smaller, but still allows a reasonable size cavity. Not having the constraint of second beam pipe, the outer walls of the eRHIC DQW cavity can be straight, as shown in Fig. 7. The cavities will have to provide a crabbing kick in the horizontal direction, thus the orientation of cavity and design of ports and ancillary may differ from HL-LHC.

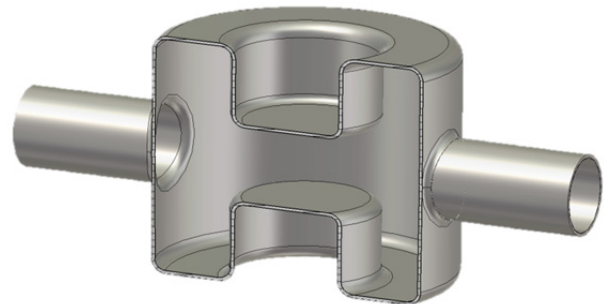

Figure 7: DQW cavity preliminary design for the crab cavity system of the eRHIC proton beam.

The crab cavities for the electron beam will also operate at 337.8 MHz. This cavity could use KEK-B cavity design or the more compact DQW cavity design.

The baseline design of eRHIC foresees crabbing for both proton and electron beams. However, crabbing the electron beam may not be needed due to the reduced dimensions of the electron bunch (30 mm long) in comparison to the proton bunch (2.4 mm wide, 70 mm long) [17]. On going studies are evaluating the impact of crabbing exclusively the proton beam.

Table 1: Crab Cavity Systems for Future Colliders (Extended From Ref. [16])

	KEK-B	ILC	CLIC	HL-LHC	JLEIC	eRHIC
Particle	electron / positron	electron / positron	electron / positron	proton / proton	proton / electron	proton / electron
θ_c (mrad)	22	14	20	0.59	50	22
Crabbing plane	H	H	H	V / H	H	H
Frequency (MHz)	509	3900	11994	400.79	952.6	337.8
Operating temperature	4.2 K	1.8 K	room	2 K	2 K	2 K
Cavity type	1-cell elliptical	9-cell elliptical	12-cell elliptical	DQW, RFD	TBD	TBD
V_{\perp} per cavity (MV)	1.4	2.05	2.55	3.4	TBD	TBD

SUMMARY AND OUTLOOK

Crab crossing was first proposed for linear colliders, but later implemented in the circular collider KEKB. Now several linear and circular colliders incorporate crab cavity systems in their designs. The main characteristics of the crab cavity systems are summarized in Table 1.

Crab cavities are essential to recover head on collisions after the introduction of a crossing angle and hence reach higher luminosities. In addition, crab cavities open up some beam gymnastics possibilities. As the beams lose particles with each collision, the bunch overlapping can be gradually increased for luminosity levelling. Also, a special combination of crab cavities can make the colliding bunches overlap over their longitudinal dimension. The so-called crab-kissing scheme may reduce pile-up density [18].

ACKNOWLEDGEMENT

The authors would like to thank Subashini DeSilva (Old Dominion University), Yue Hao (BNL) and Graeme Burt (Lancaster University) for fruitful discussions about some aspects discussed in the paper.

REFERENCES

[1] R. B. Palmer, “Energy scaling crab crossing and the pair problem,” Rep. SLAC-PUB-4707, August 1988.
 [2] Y. Funakoshi, “Operational experience with crab cavities at KEKB,” Rep. CERN-2014-004, Oct. 2014.
 [3] C. Adolphsen *et al.*, “The International Linear Collider Technical Design Report,” Rep. ILC-REPORT-2013-040, June 2013.
 [4] M. Aicheler *et al.*, “CLIC Conceptual Design Report: A Multi-TeV Linear Collider Based on CLIC Technology,” Rep. CERN-2012-007, Dec. 2012.
 [5] C. Adolphsen *et al.*, “Design of the ILC Crab Cavity System,” Rep. EUROTeV-Report-2007-010, 2007.
 [6] B. J. Wooley, “High Power X-Band RF Test Stand Development and High Power Testing of the CLIC Crab Cavi-

ty,” Ph.D. thesis, Lancaster University, Lancaster, United Kingdom, 2015.

[7] Q. Wu, “Crab cavities: past, present and future of a challenging device,” in *Proc. IPAC’15*, Richmond, Virginia, USA, May 2015, paper TXHB2, pp. 3643-3647.
 [8] S. Verdú-Andrés *et al.*, “Crab cavities for colliders: past, present and future,” *Nucl. Phys. B Proc. Suppl. 37th ICHEP*, vol. 273-275, pp. 193-197, 2016.
 [9] B. P. Xiao *et al.*, “Design, prototyping and testing of a compact superconducting double quarter wave cavity,” *Phys. Rev. ST Accel. Beams*, vol. 18, p. 041004, 2015.
 [10] S. U. DeSilva and J. R. Delayen, “Cryogenic test of a Proof-of-Principle superconducting parallel-bar RF-dipole deflecting and crabbing cavity,” *Phys. Rev. ST Accel. Beams*, vol. 16, p. 082001, 2013.
 [11] H. Park, “US-LARP crab cavity test results,” presented at the International Review of the Crab Cavity Performance for HiLumi, CERN, Geneva, Switzerland, April 2017, unpublished.
 [12] A. Castilla *et al.*, “First RF performance results for the DQW crab cavities to be used in the CERN SPS,” presented at IPAC’17, Copenhagen, Denmark, May 2017, paper MOPVA095, this conference.
 [13] V. S. Morozov, “JLEIC Interaction Region,” presented at the JLEIC Spring Collaboration Meeting, Norfolk, Virginia, USA, April 2017, unpublished.
 [14] H. Park *et al.*, “Analysis of 476 MHz and 952 MHz crab cavities for JLab electron ion collider,” in *Proc. IPAC’16*, Busan, Korea, May 2016, paper WEPMR034, pp. 2348-2350.
 [15] S. U. DeSilva, H. Park and J. R. Delayen, “Multi-cell RF-dipole deflecting and crabbing cavity,” in *Proc. IPAC’16*, Busan, Korea, May 2016, paper WEPMW022, pp. 2469-2471.
 [16] Q. Wu, “Crab cavities,” presented at the eRHIC Review, Upton, New York, USA, April 2017, unpublished.
 [17] F. Willeke, “eRHIC overview,” presented at the eRHIC Review, Upton, New York, USA, April 2017, unpublished.
 [18] S. Fartoukh, “Pile up management at the high-luminosity LHC and introduction to the crab-kissing concept,” *Phys. Rev. ST Accel. Beams*, vol. 17, p. 111001, 2014.