



CERN/AT-RF 91-29
18 October 1991

STATUS REPORT ON SC RF CAVITIES AT CERN

G. Cavallari (reporter), C. Arnaud, M. Barranco-Luque, C. Benvenuti, Ph. Bernard, D. Bloess, D. Boussard, P. Brown, S. Calatroni, E. Chiaveri, E. Ciapala, W. Erdt, P. Frandsen, F. Genesio, G. Geschonke, D. Güsewell, E. Haebel, W. Hartung(*), C. Hauviller, N. Hilleret, H.P. Kindermann, G. Orlandi, G. Passardi, E. Peschardt, V. Rödel, J. Tückmantel, W. Weingarten, G. Winkler

Abstract

The main effort of the sc.RF community at CERN was concentrated on the LEP energy upgrading program with the fabrication, test, assembly and installation of the first bulk Nb and two Nb sputter coated 4-cavity modules, each module containing four 4-cell cavities. In total the nominal installed voltage is 102 MV corresponding to an accelerating gradient of 5 MV/m. With beam the three modules were operated up to 75 VM so as to avoid trips of the interlocks during physics run, because of incomplete processing in the tunnel and to cope with the limited cryogenics power (1.2 kW). For the nominal beam current of 6 mA the beam induced RF power deposited in the cavity (below cut-off frequency) corresponds well to the theoretical expectations of about 10W. The average standby heat load per module amounts to 80 W, average technical Q-values from 1.5 to $2.6 \cdot 10^9$. Twenty more bulk Nb cavities (being assembled to five 4-cavity modules) have been ordered at industry and are being received. The first steps for the production in industry of 42 fully equipped Nb sputter coated 4-cavity modules (168 cavities) have started and the corresponding reception test areas are under preparation at CERN. In addition a new LEP type 2-cavity module is under preparation to boost the SPS lepton beams. In parallel the development program progressed, being focussed on the modification for the cryostat, design and test of a coupler with variable coupling strength ("variable coupler"), improvement of existing and development of a new HOM coupler for higher beam currents as well as improvement of cavity performance (gradient and Q-value) and studying cheaper series production techniques.

Presented at the 5th Workshop on RF Superconductivity,
19-23 August 1991, DESY, Hamburg

(*) On leave of absence from the Laboratory of Nuclear Studies, Cornell University, Ithaca, NY 14853, USA

1. Introduction

In summer 1989 the LEP machine at CERN has entered successfully into operation, producing Z^0 particles with a single beam energy around 46 GeV. Already in the design stage of LEP it was planned to upgrade the beam energy close to 100 GeV to produce W^+W^- pairs, the considerable increase of accelerating voltage to be realized by adding superconducting RF cavities.

In the framework of the corresponding R&D program individual prototype cavities have been built and tested successfully during the last years. Cavity engineering has entered now the final step towards the planned units for the LEP upgrade, called 4-cavity modules, containing four 4-cell cavities with independent helium tank and RF supply, but common insulation tank. This step was realized with the assembly, test and machine installation of three such 4-cavity modules, the first one just being under preparation at the time of the last workshop at KEK.

The planned upgrade [1] will take place in several steps, the first two already being achieved, see also figure Figure 1 :

- Installation of one prototype 4-cavity module with bulk Nb cavities close to LEP interaction point 2 (P2), including already two cavities made by industry.
- Installation of 2 further modules with sputter coated Nb/Cu cavities made at CERN (next to first module)

The future steps will be :

- 5 modules (20 Nb cavities) installed at P2, making a total of 32 sc. cavities (spring 92)
- 8 modules (32 Nb/Cu cavities) at P6 (opposite to P2) filling the immediately available space in P6 close to the copper RF with 32 cavities. In parallel 8 modules (32 cavities) in P8 (spring 93)
- Further 8 modules (32 cavities) in P8. In parallel 16 modules (64 cavities) in P4 (spring 94), yielding a total of 192 installed sc. 352 MHz cavities

Additional new klystron galleries at P4 and P8 are going to be dug and equipped correspondingly (work has already started in P8).

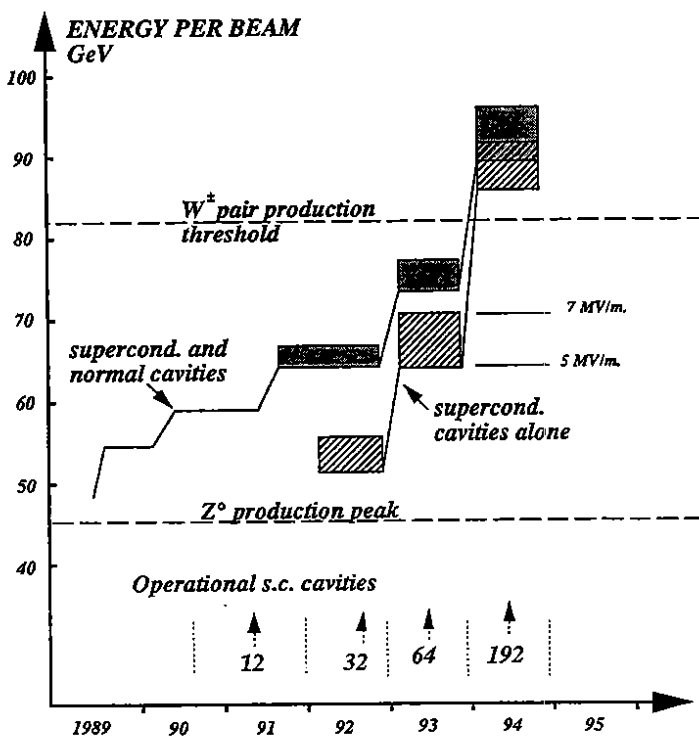

Figure 1. The planned LEP upgrading

2. Production, Test and Running of Cryomodules

2.1 The First (Nb) Module

The performance of the first four bulk Nb cavities designed to form the first LEP 4-cavity module have already been reported[2]. The module made of those cavities is fully equipped with power and higher order mode (HOM) couplers and frequency tuners. The only connection of the four cavities' He volumes is the gas collector on top. Liquid helium supply on the inclined module¹ is done equally with overflow from the higher to the lower cavities ('Roman fountain mode') or with overflow in the opposite direction. The latter solution has now been adapted as standard scheme. A liquid He manifold has been added under the cavities (communicating vessels) to ease filling and level control (module 3).

The module test was done in the 'string' test area (formerly used to test the LEP copper cavity string) already equipped with a standard 1 MW 352 MHz klystron, the RF power being distributed to the cavities over two levels of magic Tee power dividers. An existing 450 W refrigerator (4.5 K) in the same hall provides the cooling.

After cooldown and filling low power measurements were done, e.g. the Q_{ext} of the main couplers using the system bandwidth and the Q_{ext} of the probe antennas from the first measurement and the transmission. Due to manufacturing tolerances of the main couplers and field profile unflatness, the Q_{ext} of the four cavities were not equal but as shown in table Table 1.

Excited individually, all cavities exceeded the specified 5 MV/m (see table Table 1) however, operated as 4-cavity module, the total voltage of the module was 32 MV, corresponding to an averaged field of 4.7 MV/m. This was due to the common RF power generator and the different couplings causing different excitation levels, thus the cavity with the strongest excitation (16) limited the field increase of the whole module.

LEP unit number	13	14	15	16
$Q_{ext,MC} \cdot 10^6$	2.2	1.8	2.1	2.4
$E_{acc,max} \text{ MV/m}$ (indiv. exc.)	5.4	5.1	5.1	5.3

With the main coupler installed, the usual method of Q-measurement based on decay time could not be applied. Therefore a cryogenic compensation measurement for the averaged Q of the whole module was done, replacing the RF losses by an equivalent electric heating, yielding values in the range of $1.3 - 2.2 \cdot 10^9$. The lack of precision was partly due to residual oscillations of the refrigerator loops. It should also be mentioned that the ambient magnetic field in the string area was very inhomogeneous and could not be compensated very well (the module had compensation coils).

The existing installation allows to rise the field in all cavities simultaneously, but the first tests and processing (RF and He) were mainly done individually by detuning the inactive cavities. In this way the reaction of the particular cavity could be observed close to its actual performance limit and field could be changed accordingly. In this state of processing the quench detector, programmed to detect a fast field decay, often triggered on instabilities quite normal during processing or on field variations caused by thermo-acoustic He pressure oscillations.

During the tests of the individual cavities as unit ('1-cavity module') no serious problems of He pressure oscillations were encountered. In the 4-cavity module, however, the thermo-acoustic oscillations in the service pipes of the He bath volume modulated the cavity frequency so strongly that the tuner range at those modulation frequencies was exceeded and for the first module a phase jitter of up to $\pm 10^\circ$ remained in the worst case, two cavities being a factor 5 better.

After this test (Febr. 1990) the module was transported to the PM18 access shaft, the only one where objects of this size can be lowered, and from there along the tunnel to its final location at 'point 2' (P2) of LEP. This operation was difficult due to the tight space available in the tunnel, sometimes only a few cm.

¹ the LEP machine plane is inclined by 1.42 %

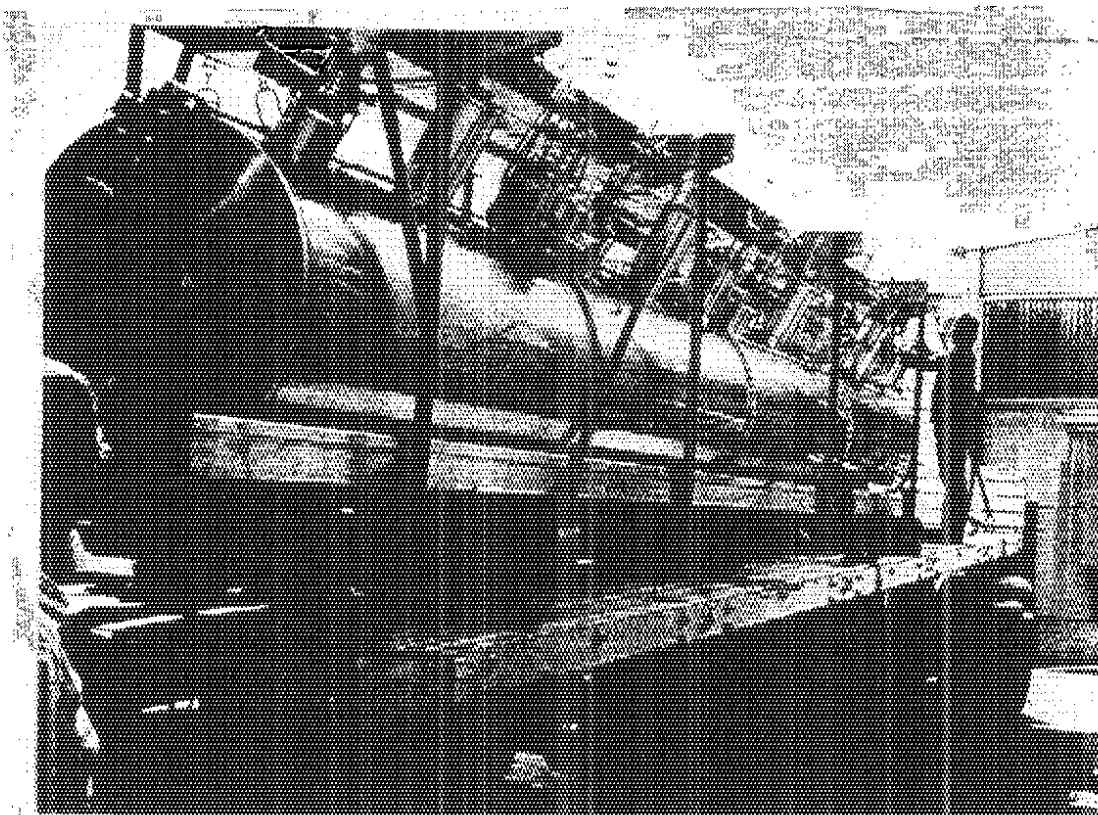

Figure 2. The first 4-cavity module (transportation)

The RF system used in the tunnel to supply the sc. cavities is very similar to the one for the copper cavities, except that in the final stage 16 sc. cavities are connected to one 1.3 MW klystron² via 4 levels of magic Tee power dividers allowing a maximum of 80 kW per cavity. It is possible to double the number of klystrons for a higher beam current, thus using 8 cavities per klystron with an available power of 160 kW per cavity. Also controls are derived from the existing system allowing a maximum of compatibility and similarity for operation. Control of the sc. cavities is possible from the local control in the klystron gallery or from the main LEP control room [3].

For the sc. cavity operation additional interlocks were necessary :

- A 'fast' quench detector triggering on the fast field decay of the corresponding cavity (klystron off)
- Fast detuning of cavities after quench (switch off magnetostrictive tuncr)
- Three levels of He gas pressure interlock (operational pressure below 1300 mbar)
 - cut klystron drive at 1350 mbar
 - cut klystron voltage at 1500 mbar
 - dump beam at 1600 mbar
- Beam dump on LHe level below HOM coupler cooling inlet

The liquid He was supplied by a refurbished existing refrigerator moved to P2 and a transfer line distribution system designed for up to 3 modules. The refrigerator delivered up to 800 W and worked until now during all LEP runs, without any serious failure. To prepare the refrigeration of 3 modules, an additional turbine was installed in the 1990/91 shut down, boosting the capacity to 1150 W.

When operating the module without beam, 30 MV total voltage could be obtained compared to 32 in the test area, further processing was not possible due to the time schedule. The thermo-acoustic He pressure oscillations continued to be a problem. No satisfactory Q-measurement could be made.

During the first LEP running period the cavities were not used, thus were detuned by about -5 kHz, half way to the next machine line. During several machine development sessions (MD) beam-cavity interactions were

² the LEP 1 MW klystron has been boosted up to 1.3 MW with only minor modifications

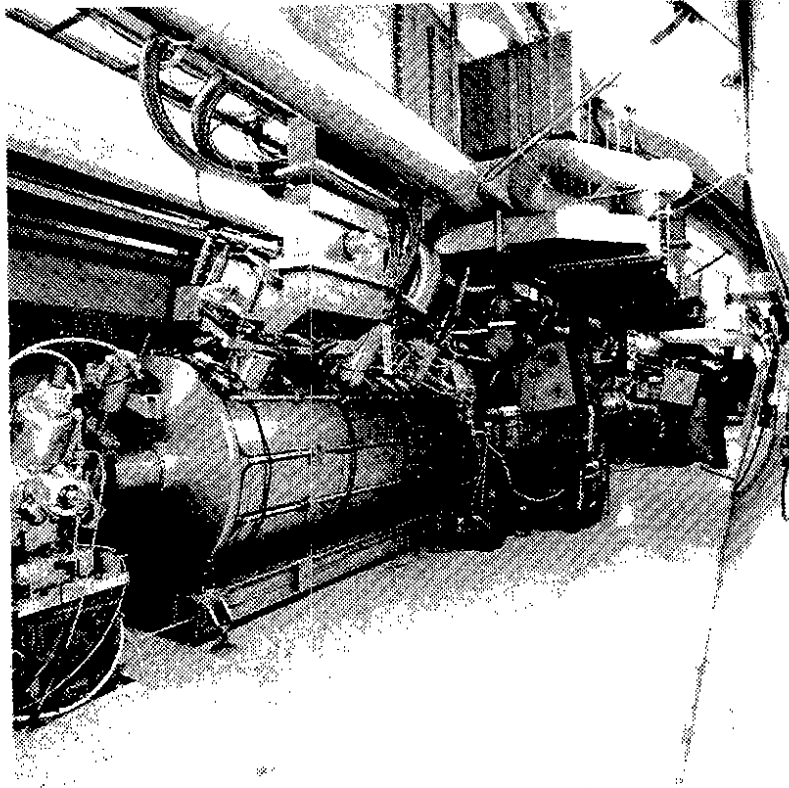

Figure 3. The first module installed in LEP

examined. The change of the LEP synchrotron frequency with the total accelerating voltage was used to confirm the accelerating voltage of the module deduced from probe antenna calibrations.

After commissioning the module was used for physics runs, including accumulation, ramping and luminosity run. 25 MV total voltage, i.e. 3.7 MV/m average field, was considered a safe operating level.

The HOM loading in the cavities was determined. For a single nominal LEP bunch 10.9 W power per cavity were expected to be coupled out for frequencies below beam pipe cut-off; we measured (and extrapolated) 12 W with a bolometric power meter. This confirms that there is no large resonant built up of HOM fields and that extrapolations to possible higher beam currents can be made with confidence on theoretical basis. The problem of the wake fields at frequencies above cut-off, however, remains still to be examined, methods of measurement and possible treatments are under preparation.

2.2 The Second (Nb/Cu) Module

The second 4-cavity module has the same cryogenics ('Roman fountains') and mechanical design as module 1, but cavities are sputter coated (Nb/Cu) and the HOM couplers are of type 5a[4]. Eight Nb/Cu cavities were in the production line to assemble two such modules.

The performance of the individual cavities can be found in table Table 2 :

LEP unit number	9	10	11	12	5	6	7	8
production number	L51	L49	L52	L47	L53	L55	L54	L57
module	2 nd	2 nd	2 nd	2 nd	3 rd	3 rd	3 rd	3 rd
$E_{ecc,max}$ MV/m	6.1	7.1	5.4	6.1	8.0	7.4	6.5	7.6
Q_0 10 ⁹ at 5 MV/m	2.6	2.8	2.9	4.8	4.8	3.8	2.8	5.0
$Q_{ext,MC}$ 10 ⁶ (string)	3.17	2.95	3.04	2.26	2.13	2.45	2.82	2.38

The first Nb/Cu module was also tested in the string area. As for module 1 He processing was applied, but one could not work at the usual pressure of about $1 \cdot 10^{-5}$ mbar. Fast break downs forced to reduce to about $3 \cdot 10^{-6}$ mbar, where processing allowed to reach 5 MV/m average field within a few hours, using simultaneous

processing of the cavities in the final stage. Due to the installation schedule we had to abandon processing at this stage.

There was no direct Q-measurement, however, we could run the module at 5 MV/m in real CW, which for module 1 quickly exceeded the production limit of the refrigerator. This allows the conclusion, that the Q-values are considerably better than for module 1. Static losses for the whole module were 90 W.

Once the module installed in LEP, again there was a longer period of idling. During special MD sessions 25 MV were obtained without beam, the limit being trips by the quench detector, sensitive to fast field decay, which is not necessarily a quench. In this case cavities 9 and 12 showed field oscillations caused by pressure oscillations at about 10 Hz which could not be compensated by the tuning system. These oscillations often triggering the quench detectors; peak/peak amplitudes of 10 mbar have been observed with frequencies between 2 and 4 Hz. During filling of the module no pressure oscillations were observed as long as only the first cavity was being filled, oscillations started, as soon as the overflow began.

Both modules together were operated at 54 MV, the limit being given by fast (10 ms) field variations in module 2, this one being slightly higher excited due to the adapted higher $Q_{ext,MC}$. With beam both modules together were operated at a safe level of 40 MV, the voltage of the second module being also confirmed with beam. No attempts were made to force higher field levels during luminosity runs.

2.3 The Third (Nb/Cu) Module

Originally the two Nb/Cu modules were planned to be installed together but one cavity showed at 5 MV/m only a Q-value of $1 \cdot 10^9$ when measured as unit, much lower than the $3 \cdot 10^9$ as bare cavity. To improve this value, find the origin of the degradation and an adequate treatment, it was decided to delay the third module. It was found out that a simple rinsing with ultrapure water could recover (even improve) the Q-value measured for the bare cavity and when reassembled as unit, there was no degradation to be observed any more.

Module 3 is nearly identical to module 2, however, it is the first 'Right' module (i.e. the main coupler is on the right side of the cavities) and there is a lower liquid collector for all He-tanks, thus the He level in all tanks is (about) the same. This fact proved to be very 'handy' during processing, where a cavity 'run dry' by processing had not to be filled by a slow sequence of overflowing vessels. To simulate the cryogenics conditions for the surface test as close as possible, the inclination of the LEP tunnel was reproduced with the module support.

The 'string' test was done as for the other modules, we found again a significant scatter in coupling strength for the main couplers (see table Table 2 on page 4). Processing up to 32 MV (4.7 MV/m average) went straight forward with RF processing but high radiation level (several kRad). Therefore He processing was started mostly in individual mode, producing less radiation. As for module 2, we could not work with the usual He pressure, but had to pump down to $2.5 \cdot 10^{-6}$ mbar. The only modification between the unit tests and the 4-cavity module test is the presence of the HOM couplers (we have also done 'standard' He processing with main coupler using a tetrode amplifier) i.e. we conclude that the observed break downs in the gas have to take place there.

At the end of the processing we obtained 36 MV (5.3 MV/m). A rough cryogenic compensation measurement was done to estimate the averaged Q-value of the module and $1.9 \cdot 10^9$ was found, a value quite in contrast to the RF determined Q-values of the individual cavities. A similar effect was also observed with the heaters in the tunnel for the other 2 modules. This difference is not yet understood.

Pulsing the klystron was made available for module 3 in the test area. Due to technical constraints of this first system, only one cavity could be monitored. Processing the whole module '1 s on, 4 s off' for about the last available hour, starting at the CW limit, the peak field of the monitored cavity could be increased by about 10%. Assuming that the other cavities follow proportionally, an average field of 5.8 MV/m was obtained in pulsed mode, to be checked in CW in the tunnel.

Thermo acoustic pressure oscillations were found also in this module and could be reduced to an acceptable level by simple modifications of the dead volumes of the helium pipes concerned. We have determined the frequency pressure dependence and found for all four cavities 8 Hz/mbar with a very low scatter. Since some cavities show higher phase jitter than others, we conclude that the pressure oscillations can vary from cavity bath to cavity bath in the same module.

When installed in LEP, one of the beam valves, closing both module ends during transport, was stuck closed and the cavity vacuum had to be broken in the tunnel to replace this valve, the operation happened without apparent incident.

First tests without beam were done and all 3 modules could deliver a total voltage of 75 MV. With circulating beam of 3.8 mA the same voltage was achieved, but due to pressure of the physics community to get a maximum integrated luminosity in LEP there was no extended running of the three modules with beam.

Module number	1 st	2 nd	3 rd
$E_{acc,aver}$ MV/m (string)	4.7	5.0	5.3
Technical Q-value 10^9 (LEP ring)	1.5	2.5	2.6
Standby losses W	75	90	75

2.4 Outstanding Problems of the LEP modules

There are still several problem areas where improvement is desirable or even necessary:

- Already without beam thermo acoustic oscillations between 6 and 10 Hz cause cavity frequency oscillations, showing up as phase oscillations of the cavity voltage with amplitudes of about 10° and corresponding voltage oscillations. These cannot be compensated by the tuning system.
- It is difficult to switch on again a unit with circulating strong beam, the beam induced voltage 'confusing' the tuner loop. Switch on procedures have to be developed.
- The fast quench detector often triggers because of residual oscillations mentioned above.
- A reliable Q_0 -measurement in the tunnel has not been possible.
- The cryogenics plant has gained in stability but further improvements of control software and automatic procedures are necessary
- The technical Q-values, including all dynamical losses, were determined by cryogenics compensation measurement, yielding the data given in table Table 3.

2.5 The SPS modules

Already at the time of the KEK workshop a unit with the bulk Nb cavity 'LEP2' was operated in the SPS to improve lepton injection from the SPS to LEP [5]. This cavity was driven by a RF feedback system with a 40 kW tetrode, annihilating all beam induced fields during the proton part of the SPS super-cycle and switching to acceleration for the following four lepton sub-cycles.

This system worked so well without any special attention, that it was decided to try a doubling of the voltage in replacing this unit by a 2-cavity module made from standard LEP type Nb/Cu sputter cavities. The risk of this decision was linked to the fact that a new refrigerator could not be ordered on short notice, but the old one had on paper just enough power to cool such a module operated in pulsed RF mode.

One cavity (L48) had to be deviated from the in house LEP production line, the second (L46) was our refurbished first full test cavity. The assembled 2-cavity module was tested as the standard 4-cavity modules in the 'string' test area. Processing allowed to increase the CW field to 5.2 resp. 4.5 MV/m, however, heating with thermal run away in the HOM couplers type 2 was observed and CW operation had to be stopped. Fortunately, in the SPS the acceleration duty cycle is very short and in such mode the module could very well be operated. Two independent RF feedback systems were used in the SPS tunnel to drive the cavities and beam measurements confirmed pulse peak fields of 5.5 resp. 4.5 MV/m, i.e. the module delivered 17 MV to the lepton beam.

No technical problems were encountered, but during real operation the cryogenics supply revealed in fact just sufficient and caused a few operational delays, e.g. when refilling after power failure. Therefore the SPS crew decided to renounce some superconducting MV, but win more operational flexibility and in autumn 1990 the 2-cavity module was removed from the tunnel, separated and the resulting unit (cavity L48) was reinstalled after a short test. Actually it runs without problems at 4.5 MV/m. The total operation time of superconducting cavities in the SPS (i.e. LEP2, 2-cavity module and L48) exceeds 20000 hours.

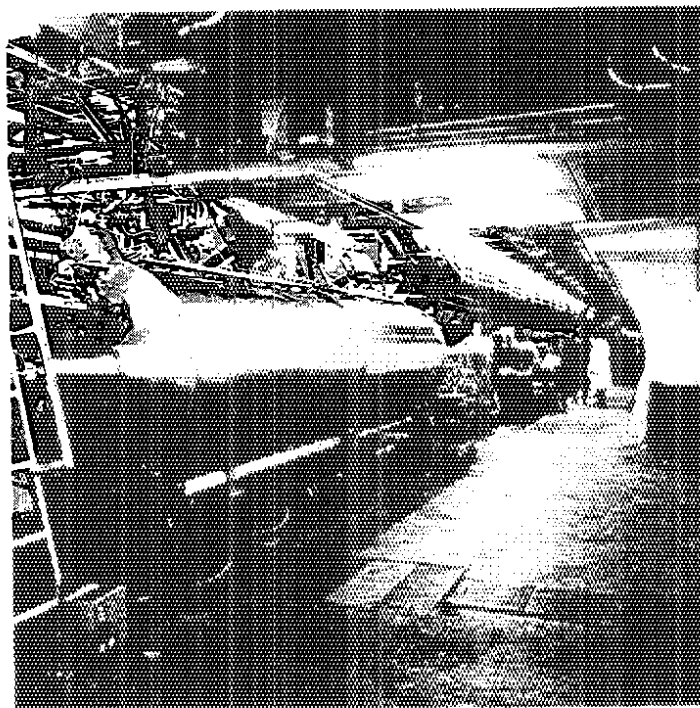

Figure 4. The 2-cavity module in the SPS

It was decided to add beginning 1992 a new 2-cavity module with a separate refrigerator, already ordered. The 2-cavity module is under preparation, made from the old bulk Nb cavity 'LEP2' and Nb/Cu cavity L46. The three installed sc. cavities will make it possible to remove some 200 MHz copper cavities, thus reducing the overall machine impedance to prepare for the future LHC beam.

2.6 Future superconducting LHC cavity

The planned Large hadron Collider LHC [6] needs less than 16 MV accelerating voltage, but a small machine impedance is primordial. Therefore it is envisaged to use 8 superconducting single cell cavities at 400 MHz operated at up to 5.3 MV/m, which accelerate both beams in the same gap. Such a cavity has been designed [7] and a prototype is under construction at CERN for testing with a high intensity proton beam in the SPS.

3. Orders and Reception of Cavities from Industry

3.1 20 bulk Niobium Cavities

The LEP energy upgrade foresees after the three 4-cavity modules already installed, 20 cavities (5 modules) of bulk Niobium, allowing to operate 2x16 cavities around P2. The manufacturer³ delivers the cavities as unit without main and HOM couplers and - after reception test at CERN - these cavities will be assembled to 4-cavity modules under the responsibility of CERN.

The first of those cavities have been measured and (after some initial start up difficulties) cavities fulfilling the specifications concerning the Q-value at 5 MV/m and generally largely surpassing 5 MV/m, start to arrive so that the assembly of the first module will start soon.

³ CERCA (F)

cavity name	Meas. date	Q(5 MV/m) 10^9	$E_{occ,max}$ MV/m
L17	6/5/91	3.4	7.05
L13	17/5/91	(2.)	6.3
L18	30/5/91	(2.6)	7.1
L12	28/6/91	3.8	8.2
L11	5/7/91	5.2	6.9
L14	5/7/91	4.	7.9
L13	12/7/91	4.	7.9
R19	26/8/91	(1.1)	5.05
R22	10/9/91	3.7	7.5
L16	13/9/91	3.7	7.7

Due to the strong inhomogeneous stray magnetic field of the big detector L3 close to our first module, we have to ask to run down the magnet when we are cooling down this module. Therefore we have replaced the compensation coils for the cavities from industry by a more expensive internal high permeability shielding, being able to cope also with inhomogeneous fields and which does not need operators to set and check currents. It should be remarked that we have made several attempts to provoke the '100 K effect' [8] in keeping the temperature during cooldown on predicted dangerous levels, but it could never be observed.

3.2 160 Sputter Coated Cavities

To achieve the LEP energy upgrade, the main bunch of cavities will be of Nb/Cu sputter coated type and the order was shared by three European firms⁴, two of them having already delivered LEP type cavities to CERN. The design field was asked to be 6 MV/m with a Q-value of $4 \cdot 10^9$ at this field level. For those cavities CERN will receive the bare sputtered cavities to check the sputtered layer, avoiding a costly assembly of a cavity with defect into a 4-cavity module. These bare cavities will be sent back to the manufacturer and CERN will receive finally fully equipped 4-cavity modules, only the power coupler will be mounted with reduced coupling (some 10^9), allowing to control the specified Q(E) curve. To do these tests, CERN is actually installing a large test area in the SM18 hall.

To guarantee for some vital components (e.g. special steel ingots for vacuum flanges, Ni tubes, heater wire, rectangular copper wire for the tuners, vacuum tight feed-through, low loss RF cables) the quality and uniformity for all manufacturers, CERN has ordered those components under its own responsibility.

All three contractors are preparing the necessary installations like electron beam welding apparatus, chemistry, clean rooms and sputter apparatus, first bare copper cavities have been produced and first Nb test films have been sputtered. All this activity demands considerable attention from CERN especially during the beginning to allow a smooth transition to production. The first prototypes of bare cavities are expected this summer, the first full modules beginning 1992.

3.3 Couplers

Also the fabrication of the main and HOM couplers will be done in industry⁵ and a separate contract has been placed. HOM coupler type 5b [4] (see figure Figure 7 on page 11) will be used, giving satisfactory results on the two Nb/Cu modules in LEP.

In the meantime a power coupler with variable coupling has been developed and conditioned up to 180 kW and therefore it is highly probable that the cavities will be equipped with those as soon as possible.

⁴ ANSALDO (I), CERCA (F), SIEMENS (former INTERATOM) (D)

⁵ SICN (F)

4. The Cavity Reception Test Areas

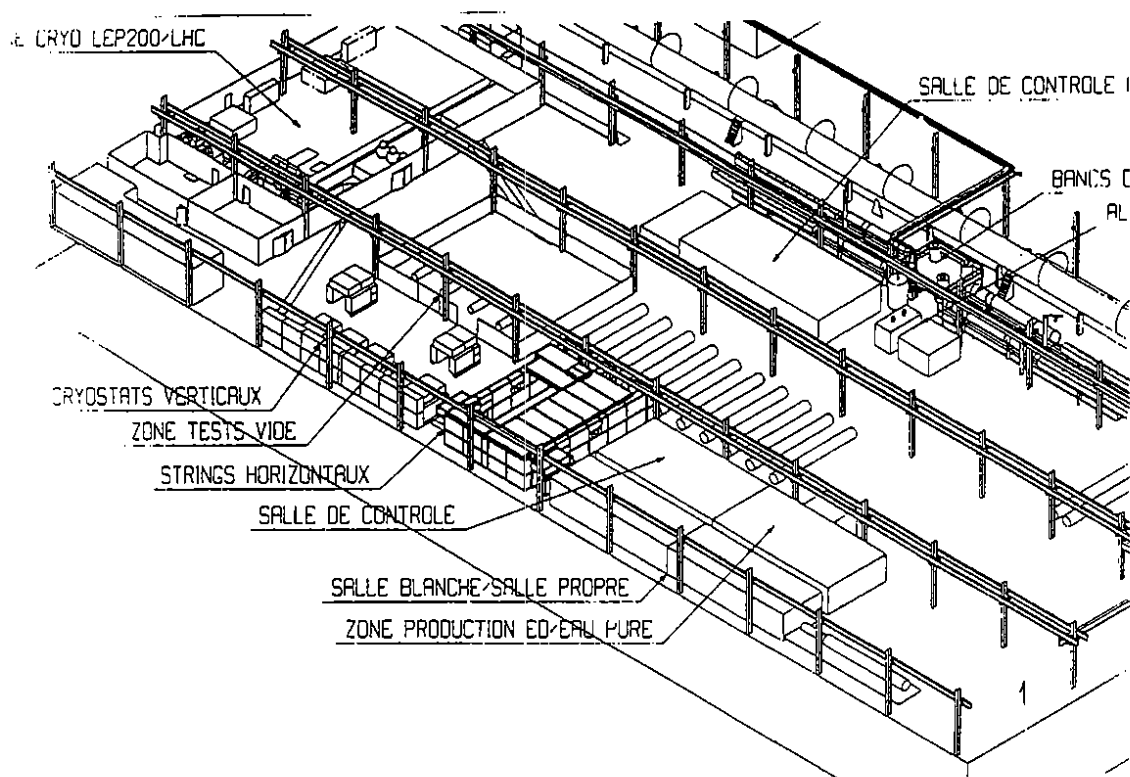

Figure 5. Sketch of the test area under construction

The tight schedule for the LEP upgrade asks for a smooth and fast execution of the necessary acceptance tests of cavities and 4-cavity modules. The actual measurement capacity is not adequate at all and therefore a new test facility is under preparation in the hall SM18, used for the LEP installation before.

Work is under way for

- 4 (possibility to upgrade to 6) individually radiation shielded cryostats for the check of the bare cavities, allowing to process cavities while other ones are being prepared for measurement or being dismantled.
- Two independent bunkers to house a 4-cavity module each for the final acceptance test, including field and Q(F) performance. These tests will be done with 300 W solid state amplifiers, one per cavity, allowing to process each cavity just at its performance limit.
- A common control room housing the low power RF equipment as synthesizer, power meters, lock system as well as the control computers e.g. driving the temperature mapping system available for the prototypes and special cases or piloting the cavity processing.
- A central 6 kW refrigerator with 25000 l He dewar serving the different clients independently.
- A clean room (class 100) large enough for a full 4-cavity module allowing clean mounting of the main couplers and to respond to possible cavity accidents
- High purity water installation for cavity and coupler rinsing.
- Test benches for processing of the main couplers before installation onto the cavities.

After the successfully passed acceptance test the main couplers will be mounted with strong coupling for the beam in the clean room (fixed coupler) respectively the variable couplers pushed to 'beam' position. To be also ready to measure a cavity in this state in exceptional cases (e.g. vacuum accident), a mobile 50 kW tetrode amplifier will be available. Before being installed in the LEP tunnel, each 4-cavity module will be tested in its final configuration with the feeder arrangement as in LEP with one common power source.

5. Modifications, Improvements and Future Aspects

5.1 Cavity and Cryostat Modifications

Due to outside constraints (LHC project [6]), the domes of the cavities had to be turned axially from 32° to 45°. This decision came too late for the first 32 cavities, however, all Nb/Cu modules from industry will be made like this.

We kept the modular structure of the units to produce modules of any number of cavities and also the possibility to open the cryostat without welding, thus the steel skins for vacuum tightness were kept. The change of the cavity ends concerns only the cut-off tube, however, the feeding RF system has to be modified considerably. The resultant (rotated) position of the HOM couplers would hide them partly below the longitudinal girder of the existing cryostat, making them inaccessible. To resolve this problem and to allow - for the already proposed current increase in LEP - HOM couplers with fixed coaxial lines, the cryostat frame was redesigned with two longitudinal girders and correspondingly two metal sheets and O-rings for leak tightness (see figure Figure 6). The cryostat flanges are made from aluminum and Helicoflex (R) metal gaskets will be used to join the individual 'cryostats' to a module.

The inner structure of the cryostat has also been modified. Measurements have shown that replacing the gas cooled radiation shield by more layers of superinsulation led to only 2-3 W additional cryogenic losses per cavity, but saving the construction and assembly cost of the shield and its pipework. To reduce the risk of a He gas leak into the insulation vacuum, copper pipes and brazings were replaced by stainless steel pipes and mostly automatic TIG welding. To cover the lower mechanical strength of the copper cavities, the He discharge safety line was increased from 50 mm diameter to 80 mm and equipped with a 'diffuser' outlet to achieve maximum discharge capacity.

A prototype was built this way (cavity '645') and is undergoing preliminary tests.

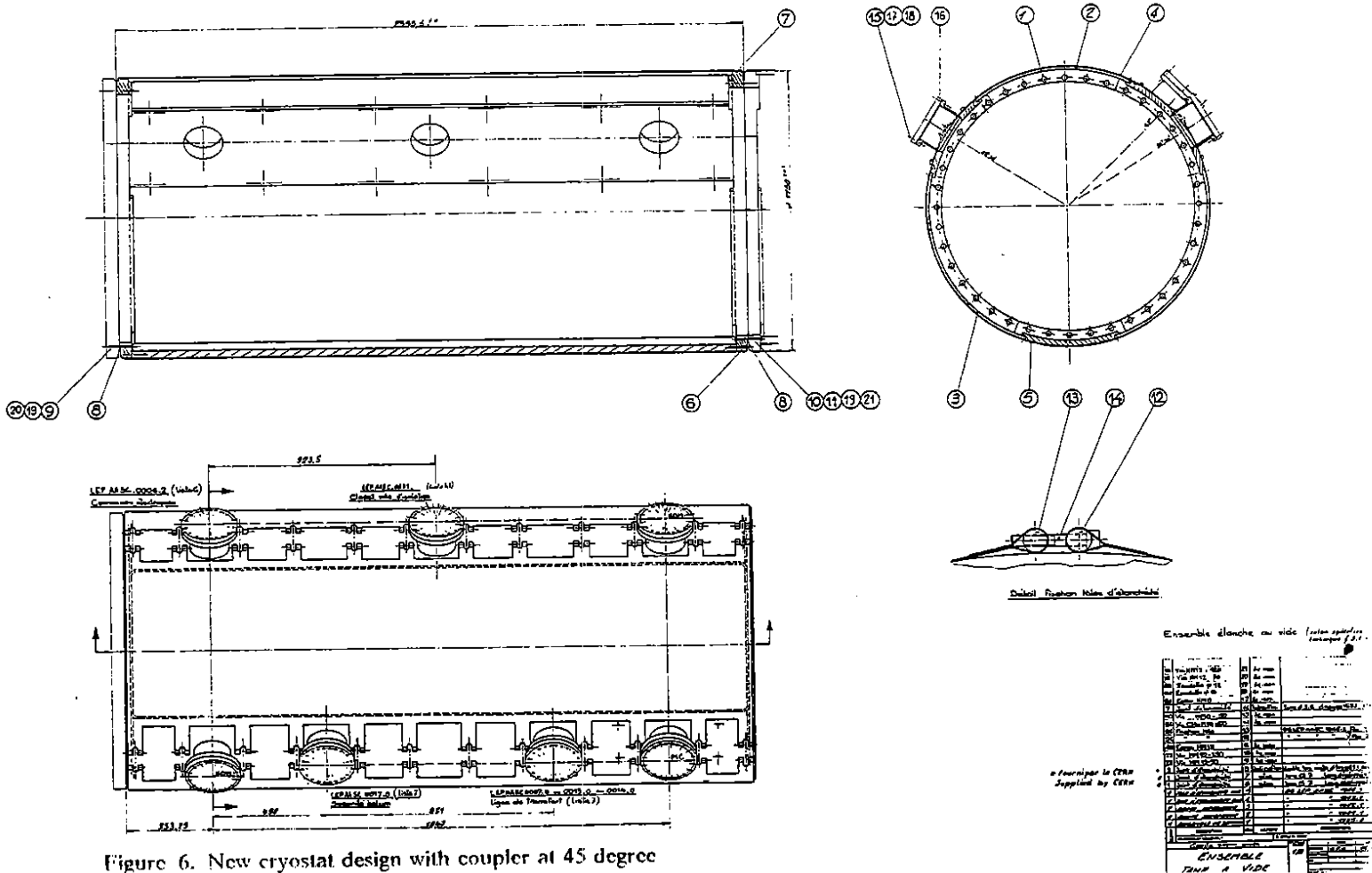

Figure 6. New cryostat design with coupler at 45 degree

5.2 HOM Coupler Improvements

The HOM coupler [9] type 1, as used on module 1, was not well adapted for sputter cavities due to a lateral RF outlet and lateral positioning pins. HOM coupler 2 [9] showed good RF performance operated on the SPS '2-cavity module' in pulsed mode. The severer conditions in LEP (including the option of even higher beam current) triggered - in collaboration with the ALS group in Saclay - the development of coupler type 5a, which had even better RF performance and a much reduced risk of overheating. The only drawback was that the liquid helium was separated from the beam vacuum only by the RF window, considered an unhealthy situation. Coupler 5b was the outcome of a corresponding modification, removing the window problem in keeping the good RF performances of 5a. To cope with the power coupled out for a high intensity beam, a power splitter and two cables inside the cryostat can be used.

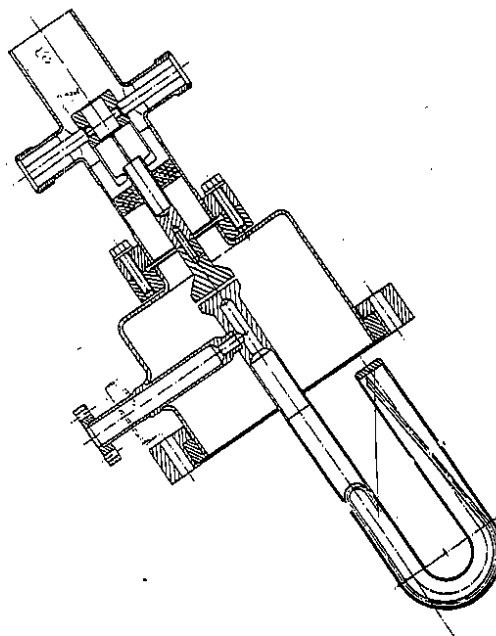

Figure 7. The HOM coupler type 5b

5.3 The Variable Main Coupler

A main coupler with variable coupling strength ('variable coupler') is useful for the foreseen operation schemes of LEP, high energy beams or high intensity beams. Such plans have pushed to the development of such a coupler. It allows also to compensate the fluctuations of the coupling constants observed on the first three modules. The coupling range obtained was from $2.5 \cdot 10^5$ to $2.5 \cdot 10^9$, thus allowing even to determine Q_0 with sufficient precision in the tunnel. It was conditioned up to a CW power of 180 kW for one week and is under test on a cold cavity.

5.4 Monolithically Hydroformed Cavities

Our cavities are actually produced from half cells made by spinning, being electron beam welded to 4-cell cavities. To reduce the length of welding seams (only cut-off tubes) and with it the cost, monolithical hydroforming of cavities from tubes made of copper was tried with success [10]. Starting with smaller cavities, 352 MHz single cells were formed from SE and OFHC copper. Finally even a full 352 MHz 4-cell cavity was made from a single tube of SE type copper, but all tests for full size 352 MHz 4-cell cavities with tubes of OFHC copper did not succeed.

To test the surface quality of copper treated in this way, two of such 352 MHz single cells have been sputtered with Nb as for the standard LEP cavities. The Q-value of the first cavity at 5 MV/m was $5 \cdot 10^9$ and the peak field 10 MV/m, the second cavity had only a very low performance for reasons not yet understood.

In view of the interest for low cost cavities at frequencies around 1500 MHz, mono- and multicells using extruded OFHC copper tubes (on the market) were produced with 3 forming and thermal cycles resulting in a mechanical tolerance of about 10^{-3} . Sputtering of those cavities was checked for single cells with good results (see also the chapter on 1500 MHz cavities) but remains to be done for 352 MHz 4-cell cavities.

5.5 New Types of Sputtered Films

One of the advantages of sputter coated cavities is that one can rather easily change the material to be sputtered, once the technology tested out. Niobium nitrides and its derivatives (e.g. $NbTiN$) are possible materials with higher T_c than Niobium [11]. Cavities at 500 MHz were sputtered with this type of layer giving very high Q-values at low field but a much steeper slope of the Q(E) curve than the pure Nb sputter layer [12].

5.6 Sputter Film Studies at 1500 MHz

Smaller cavities allow a much faster turn over of measurements and in the same time future machines are planned with frequencies higher than used now for LEP. These cavities allow thus to study methods to reduce electron loading, obtain high gradients in a reproducible way and observe properties of hydroformed cavities. Therefore a small test stand for 1500 MHz cavities was built up and run in. At CERN there existed only a design for such a sputter device, but the AIS group at Saclay have realized it for their R&D work and have sputtered a few test cavities (produced by hydroforming at CERN) with a Nb film using CERN technology. The first measurements [13] are summarized in table Table 5:

Table 5. 1500 MHz sputter studies			
Cavity	Q(0) 10^9	E_{max} MV/m	limitation
$\Lambda 1$	10.	5.8	e^- loading
$\Lambda 1$	20.	14.	e^- loading
$\Lambda 2$	2.	3.2	e^- loading
B1	8.	5.5	Q-switch
B2	10.	2.4	Q-switch
B3	6.	4.0	Q-switch

References

- [1] C. Wyss, "The LEP Energy Upgrade Programme," *Proceedings PAC91, May 1991, San Francisco or CERN/AC-L200/91-03*, 1991.
- [2] C. Arnaud et al., "Status report on superconducting Nb cavities for LEP," in Y. Kojima, editor, *Proc. of the 4th Workshop on RF Superconductivity, Tsukuba*, p. 19, 1989.
- [3] G. Cavallari and E. Ciapala, "Superconducting cavity controls in LEP," *CERN/EF/RF 88-47*, 1988.
- [4] E. Haeberl, "Couplers and Windows: Update on Recent Developments and New Ideas (review talk)," *This conference*, 1991.
- [5] D. Boussard et al., "Long term test of a LEP prototype sc. cavity in the CERN SPS," *Proc. of Nat. Acc. Conf., Chicago, 1989*, 1989.
- [6] The LHC study group, "Design Study of the Large Hadron Collider (LHC)," *CERN 91-03 (pink book)*, 1991.
- [7] V. Rödel and L. Verolino, "Geometry of a superconducting 400 MHz accelerating cell for the LHC," *CERN-SL/RFS/Note 91-11*, 1991.
- [8] B. Bonin, "Q-Degradation: Experience at Different Laboratories, Possible Explanations and Cures (review talk)," *This conference*, 1991.
- [9] G. Cavallari, E. Haeberl, Ph. Legendre and W. Weingarten, "Coupler Developments at CERN," in K. Shepard, editor, *Proc. of the 3rd Workshop on RF Superconductivity, Argonne*, p. 565, 1987.
- [10] S. Dujardin, J. Genest, C. Hauviller, R. Jaggi, B. Jean-Prost, "Hydroforming monolithic cavities in the 300 MHz range," *Proceedings EPAC 90*, 1990.
- [11] C. Benvenuti, "Superconducting coatings for RF accelerating cavities - Past, present and future," *This conference*, 1991.
- [12] C. Benvenuti, S. Calatroni, M. Hauer, M. Ministrini, and G. Orlandi and W. Weingarten, "(NbTi)N and NbTi Coatings for Superconducting Accelerating Cavities (poster)," *This conference*, 1991.
- [13] Ph. Bernard, D. Bloess, P. Bosland, W. Hartung, C. Hauviller and J. Martignac and W. Weingarten, "Superconducting Niobium Sputter Coated Cavities at 1500 MHz (poster)," *This conference*, 1991.