

## Evaluation of a commercial AdvancedTCA board management controller solution (IPMC)

This content has been downloaded from IOPscience. Please scroll down to see the full text.

2016 JINST 11 C02044

(<http://iopscience.iop.org/1748-0221/11/02/C02044>)

View [the table of contents for this issue](#), or go to the [journal homepage](#) for more

Download details:

IP Address: 131.169.5.251

This content was downloaded on 18/02/2016 at 20:26

Please note that [terms and conditions apply](#).

TOPICAL WORKSHOP ON ELECTRONICS FOR PARTICLE PHYSICS 2015,  
SEPTEMBER 28<sup>TH</sup> – OCTOBER 2<sup>ND</sup>, 2015  
LISBON, PORTUGAL

## Evaluation of a commercial AdvancedTCA board management controller solution (IPMC)

---

J. Mendez,<sup>1</sup> V. Bobillier, S. Haas, M. Joos and F. Vasey

CERN,  
1211 Geneva, Switzerland

E-mail: [julian.mendez@cern.ch](mailto:julian.mendez@cern.ch)

**ABSTRACT:** The MicroTCA (MTCA) and AdvancedTCA (ATCA) industry standards have been selected as the hardware platform for the upgrade of the electronic systems of some of the experiments at the Large Hadron Collider (LHC). In this context, the electronics support group for experiments at CERN is running a project to perform technical evaluations of MTCA and ATCA equipment. As part of this activity, a commercial solution for an Intelligent Platform Management Controller (IPMC), an essential component of any ATCA blade design, is being evaluated. We validated the supported IPMC features, checked the interoperability and adapted the reference design for use on an existing ATCA carrier board.

**KEYWORDS:** Modular electronics; Detector control systems (detector and experiment monitoring and slow-control systems, architecture, hardware, algorithms, databases)

---

<sup>1</sup>Corresponding author.

---

## Contents

<b>1 Overview</b>	<b>1</b>
1.1 ATCA standard: Hardware Platform Management	2
1.2 Commercial IPMC solution	3
<b>2 Technical evaluation</b>	<b>4</b>
2.1 Evaluation process and setups	4
2.2 Technical evaluation outcome	6
<b>3 CERN IPMC mezzanine based on the Pigeon Point solution</b>	<b>7</b>
<b>4 Conclusion</b>	<b>8</b>

---

## 1 Overview

Originally developed for the telecommunication industry, MTCA and ATCA standards have been selected as platforms for the modular electronics for the upgrade of the LHC experiments at CERN. The ATLAS and CMS experiments are developing xTCA based off-detector electronics (for trigger and data-acquisition applications). In this framework, the CERN PH-ESE group launched in 2011 the xTCA evaluation project whose aim is to perform technical evaluation of equipment and to provide support for the selected components across experiments [5]. The MTCA and ATCA standards, defined by the PCI Industrial Computer Manufacturer Group (PICMG), outline a modular architecture by describing physical, electrical and functional specifications. They offer a wide range of hardware management features to monitor (temperatures, voltages, current, etc.) and control (fan speed, power management, etc.) the system as well as to ensure proper operation (modules compatibility, current requirement, e-keying, etc.). These actions are performed by specific controller modules which are interconnected via an Intelligent Platform Management Interface (IPMI) bus: Module Management Controller (MMC) for AMCs, Intelligent Platform Management Controller (IPMC) for ATCA boards, and Carrier IPMC for ATCA carrier as well as Shelf Manager for ATCA shelves and MicroTCA Carrier Hubs. In the frame of the CERN xTCA evaluation project, an MMC has been adopted from other developments in the community [6]. This MMC has been improved and is now a supported device used on different AMC projects. On the ATCA front, a commercial carrier IPMC solution from Pigeon Point is being evaluated. The IPMC solution offers the features required by the ATCA standard such as ATCA and AMC management, power management, sensor monitoring and standardized remote upgrade capability (HPM.1, HPM.2 and HPM.3). These features have all been tested successfully using a starter kit. In parallel, an adapter card has been designed to understand the level of flexibility the commercial IPMC solution offers when implemented in an existing ATCA board design with specific IPMC form factor (VLP DIMM-DDR3 defined by the LAPP mezzanine IPMC [4]).

This paper presents the IPMC functionality evaluation results, the design of the IPMC adapter card, the outcome of the commercial IPMC mezzanine adaptation to an existing ATCA carrier blade as well as the design of a CERN IPMC mezzanine card.

## 1.1 ATCA standard: Hardware Platform Management

AdvancedTCA (Advanced Telecommunication Computing Architecture) is an open architecture described by a series of standards from PICMG [1]. This platform, mainly used for telecom, medical, military, industrial and physics applications, offers multiple advantages: modularity, interoperability, massive data bandwidth on backplane, power and cooling redundancy as well as a standardized and redundant central management system. The Hardware Platform Management described by the AdvancedTCA standard specifies an interface to monitor sensors (voltages, temperatures, etc.), control the system (power management, port/clock activation, etc.) and ensure proper operations (compatibility between the different boards, hot swap, redundancy, etc.).

The hardware management is performed via modules described by the AdvancedTCA standard. All these modules, listed below, are interconnected via I2C buses. The communication protocol is based on the Intelligent Platform Management Interface (IPMI) [2] standard specified by Intel. Figure 1 introduces the hardware management modules and their interconnections:

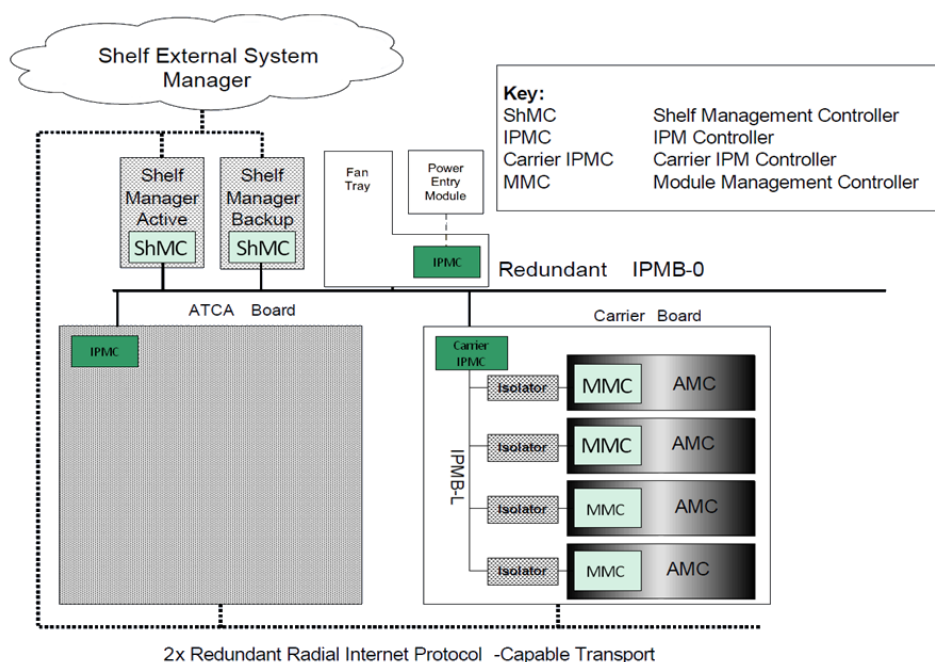

**Figure 1.** ATCA Hardware Platform Management.

The *shelf manager* monitors and controls an entire shelf. This module checks the health of the system and controls the power as well as the cooling of the crate.

*Cooling units*, also called fan trays are controlled by the shelf manager to provide a sufficient airflow across the blade.



interfaces for debug and Ethernet with RMCP support to send IPMI commands directly to the IPMC. The starter kit, included in the license package, is based on an interconnection card hosting the Pigeon Point IPMC mezzanine. This setup implements the following features:

- Shelf Manager
- Emulated AMC and AMC connector
- Emulated non-intelligent RTM
- UART and Ethernet interfaces
- User I/Os

## 2 Technical evaluation

This section presents the commercial IPMC technical evaluation process, the setups used to assess the module characteristics and finally the results obtained.

### 2.1 Evaluation process and setups

The first evaluation phase consisted of testing the Pigeon Point solution. In parallel to the specification check, the functionalities listed below were tested using the Pigeon Point starter kit:

- Management of the ATCA blade and up to 8 AMCs + 1 intelligent RTM
- Providing 16 I/Os to control IPM features (power enables, e-keying . . . )
- Providing 35 user I/Os and 2 user I2C
- Providing serial and Ethernet interfaces

Due to the starter kit limitations, only the management of 2 AMCs (one emulated AMC and one homebuilt AMC Test board hosting a CERN MMC mezzanine) was tested instead of the expected 8 AMCs + 1 intelligent RTM.

In order to overcome this restriction and test the IPMC in a custom environment, the module was tested in a second evaluation phase with an existing ATCA board. Many custom ATCA blades have been designed featuring a connector compatible with the existing LAPP IPMC mezzanine (DIMM-DDR3 VLP form factor). Hence, an adapter PCB was designed and produced to evaluate the commercial IPMC in a real ATCA environment. The adapter card was designed in order to provide a connectivity compatible with the LAPP IPMC connector pinout (figure 3).

This adapter card is mainly based on the Pigeon Point IPMC mezzanine connector and a CPLD to allow rerouting of the signals to the DIMM-DDR3 VLP connector (LAPP connector). The block diagram (figure 4) shows its architecture.

Most of the signals present on the Pigeon Point IPMC mezzanine connector are directly routed to the FPGA. Therefore, their assignment and functionality can easily be changed. To take full advantage of this, the IPMC adapter card was designed to be customizable: signal routing from the Pigeon Point IPMC to the LAPP connector can be modified easily using a MAX V CPLD from

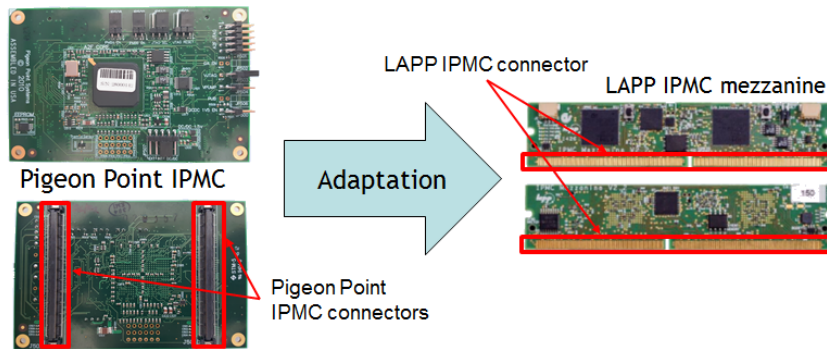

**Figure 3.** Form factor adaptation is required to use Pigeon Point IPMC with carrier blade based on LAPP-IPMC.

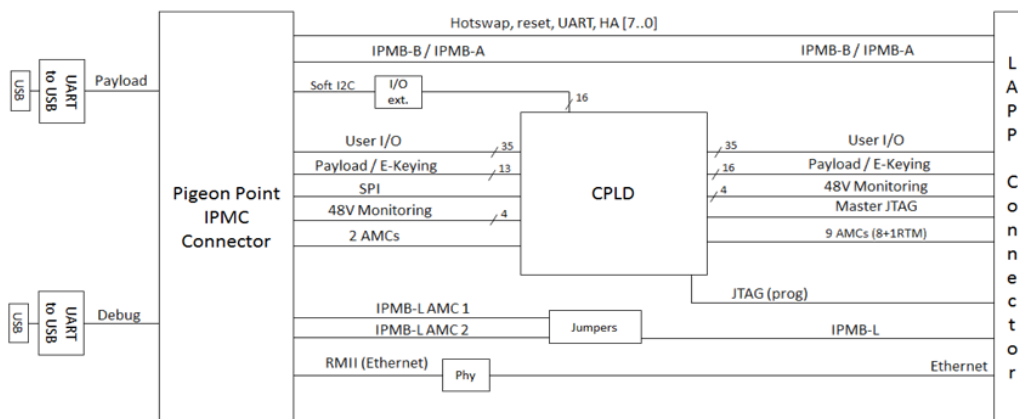

**Figure 4.** IPMC adapter card block diagram.

Altera. Additional USB interfaces (UART to USB) are implemented for the debug terminal and payload interface (IPMI interface). The PHY component provides an Ethernet interface and the I/O extender offers additional pins for the AMCs management.

This card can be used to test all the features supported by the LAPP IPMC pinout. The Pigeon Point IPMC was used with a custom ATCA carrier blade provided by LAPP (figure 5).



**Figure 5.** Test setup using LAPP ATCA test blade.

The IPMC FPGA firmware was modified to implement new drivers for the various non-Pigeon Point supported chips implemented on the LAPP ATCA carrier (sensors, AMC power switches). The AMC Test Board hosting the CERN MMC mezzanine was successfully used to test all AMC management features except the RTM features.

## 2.2 Technical evaluation outcome

The list below shows the features tested with the previously described setup:

- Communication with the Shelf Manager
  - IPMB packets successfully checked using the beagle I2C analyzer tool and Wireshark
  - ATCA blade and AMCs successfully detected and controlled by the Shelf manager
- Communication with the IPMC via Ethernet (HPM.2)
  - IPMI commands successfully sent using ipmitool over Ethernet
- Management of up to 4 AMCs
  - IPMC firmware successfully customized to manage up to 4 AMCs according to the LAPP ATCA implementation (specific DC/DC regulators, port e-keying . . .)
- Adding Pigeon Point supported and non-Pigeon Point sensors
  - Adding and removing of sensors successfully tested using the starter kit
  - Sensor drivers written and successfully tested by monitoring LAPP ATCA blade specific sensors
- Remote upgrade of the IPMC using the HPM.1 standard
  - Remote upgrade of the IPMC and AMC-MMC using HPM.1 successfully tested
- Adding OEM (user-specific) commands
  - Command with input parameter successfully implemented
  - Command with returned value successfully implemented
- Management of non-intelligent RTM
  - Management of non-intelligent RTM successfully tested using the Pigeon Point starter kit
- Management of intelligent-RTM (to be tested)
  - Management of intelligent-RTM not tested yet. Feature not implement on the LAPP ATCA test board.



### 3 CERN IPMC mezzanine based on the Pigeon Point solution

Following the positive evaluation results obtained with the adapter card, the decision was taken to design a Pigeon Point based IPMC mezzanine compliant with the DIMM-DDR3 VLP form factor. The first challenge was to validate the implementation feasibility on a rather limited area (DIMM-DDR3 VLP). Therefore, a representative mechanical drawing (figure 6) was made with the main required components to verify that everything fits.

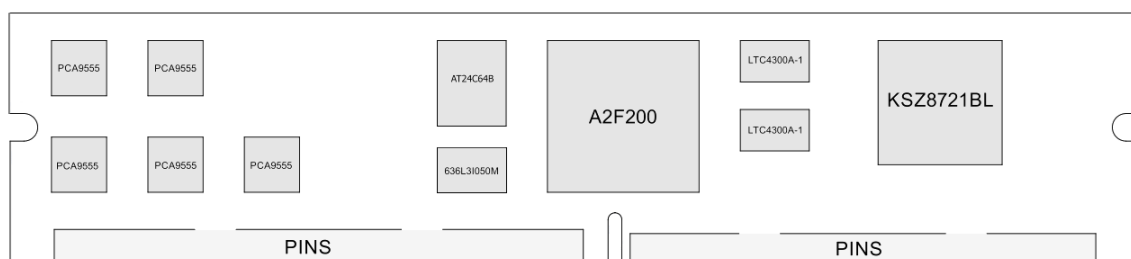

**Figure 6.** IPMC mezzanine feasibility mechanical design (top view).

Due to the limited space available, the smallest FPGA supported by Pigeon Point was selected, forcing the addition of I/O extenders for the AMC's management signals. This solution was successfully tested using the adapter card as described in the section 2.

The A2F200 FPGA design was modified to meet the specification summarized in the following block diagram (figure 7):

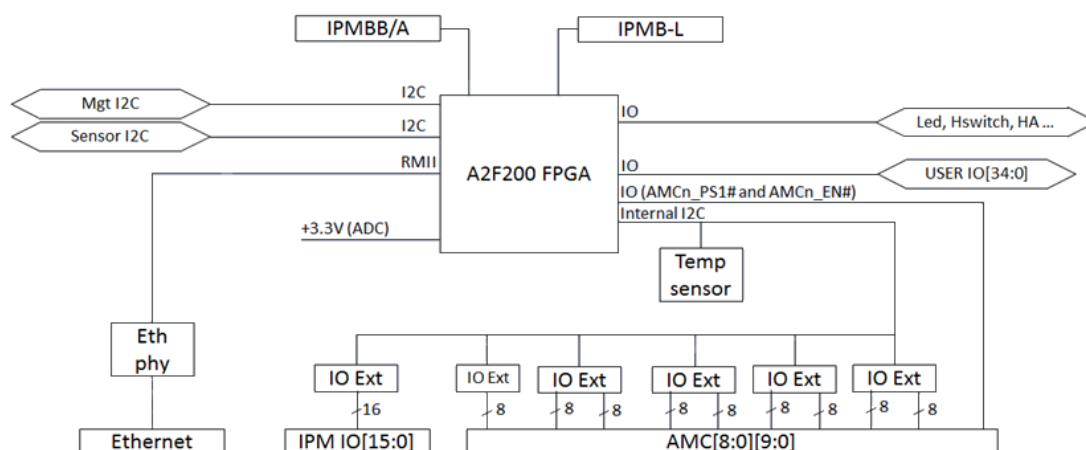

**Figure 7.** IPMC mezzanine card block diagram.

The layout is now complete and the mezzanine card prototype production will be launched before the end of the year. Figure 8 shows the top view of the IPMC card.

The next step will consist of modifying the IPMC firmware to implement the hardware required features as well as to build a user space for board customization (sensors monitoring, OEM commands, etc.).

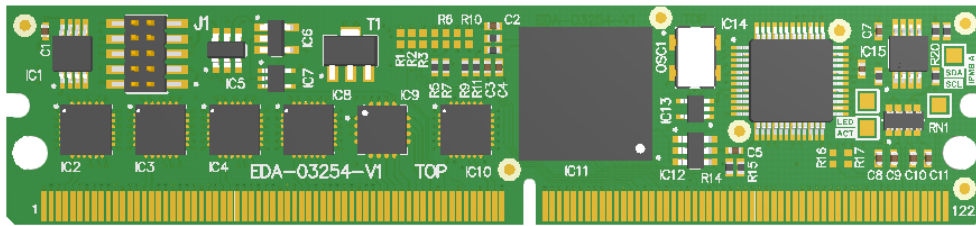

**Figure 8.** IPMC mezzanine card top view.

## 4 Conclusion

The Pigeon Point Hardware and Software IPMC solution was acquired by CERN to perform its technical evaluation. The evaluation of the product was performed using the starter kit included in the license package and a real ATCA environment based on the LAPP carrier board. Following the positive results obtained with the adapter card on the LAPP carrier board, a LAPP-IPMC form factor compliant mezzanine was designed. The schematic and the layout of this mezzanine have been reviewed and a prototype series will be produced before the end of the year. Following the validation of the intelligent-RTM feature and the adaptation of the IPMC firmware (user part for easy customization), the next step will consist of testing this mezzanine on different ATCA blades. Finally, the mezzanine will be tested with multiple blades running in a common shelf (testing possible interoperability conflicts). In case of success, a CERN IPMC hardware and software solution might become available to experiments developing ATCA hardware.

## References

- [1] PICMG, *AdvancedTCA Short Form Specification*, <https://www.picmg.org/openstandards/advancedtca/>, January 2003.
- [2] Intel, *The Intelligent Platform Management Interface Specification*, <http://www.intel.com/content/www/us/en/servers/ipmi/ipmi-specifications.html>.
- [3] Pigeon Point, *Pigeon Point's PICMG products*, [http://www.pigeonpoint.com/products\\_picmg.html](http://www.pigeonpoint.com/products_picmg.html).
- [4] LAPP, *IPMC mezzanine card*, <http://lappwiki.in2p3.fr/wiki/bin/view/AtlasLapp/ATCA>.
- [5] M.D. Cosmo, V. Bobillier, S. Haas, M. Joos, S. Mico and F. Vasey, *MicroTCA and AdvancedTCA equipment evaluation and customization for LHC experiments*, 2015 *JINST* **10** C01008.
- [6] CERN, *Module Management Controller (MMC)*, [https://espace.cern.ch/ph-dep-ESE-BE-uTCAEvaluationProject/MMC\\_project/default.aspx](https://espace.cern.ch/ph-dep-ESE-BE-uTCAEvaluationProject/MMC_project/default.aspx).