

Design of the ATLAS New Small Wheel Gas Leak Tightness Station for the Micromegas Detector Modules

Evangelos N. Gazis / National Technical University of Athens – NTUA on behalf of the ATLAS MUON Collaboration

Abstract– In this work we describe advanced data processing and analysis techniques intended to be used in the gas tightness station at CERN for Quality Assurance and Quality Control of the New Small Wheel Micromegas Quadruplets. We combine two methods: a conventional one based on the Pressure Decay Rate and an alternative-novel one, based on the Flow Rate Loss. A prototype setup has been developed based on a Lock-in Amplifier device and should be operated in conjunction with the gas leak test via the Flow Rate Loss. Both methods have been tested by using emulated leak branches based on specific thin medical needles. The semi-automatic data acquisition, monitoring and processing system is presented also in this work while a more sophisticated environment based on the WinCC-OA SCADA is under development.

I. INTRODUCTION

THE ATLAS detector [1], and in particular, the forward region of the Muon Spectrometer will be upgraded to have better performance at the expected high luminosity of the improved LHC operation. The innermost station of the end cup region will be replaced by a new system (New Small Wheel) [2]. MicroMegas (Micro-Mesh Gaseous Structure MM) detectors [3] have been chosen as the main tracking chambers and, at the same time, will also contribute to the trigger which will be provided in cooperation with the small-strip Thin Gap Chambers (sTGC).

The upgrade is to retain the good precision tracking and trigger capabilities in the high background environment expected with the upcoming luminosity and energy increase of the LHC [4], [6].

II. THE NEW SMALL WHEEL FOR THE ATLAS UPGRADE

The New Small Wheel (NSW) upgrade is motivated primarily by the high background rate that is expected at luminosity in the range of $2\text{-}5 \times 10^{34} \text{ cm}^{-2} \text{ s}^{-1}$ during LHC Run-3 and HL-LHC [3].

NSW will replace with fast, high rate, precision detectors for rates up to 15 kHz/cm^2 with resolution $100 \text{ }\mu\text{m/plane}$. NSW will provide improved trigger level1 and tracking for forward muons, working up to the ultimate luminosity value of $7 \times 10^{34} \text{ cm}^{-2} \text{ s}^{-1}$ and will reduce the fake triggers by requiring high quality ($\sigma_0 \sim 1 \text{ mrad}$) pointing segments at trigger level [5].

Evangelos N. Gazis is with the National Technical University of Athens, 9 Heron Polytechniou, 15780 Zografou Campus, Athens, Greece. (telephone: +30-210-772-3003, e-mail: Evangelos.Gazis@cern.ch).

III. GAS TIGHTNESS TEST SETUP AND CALIBRATION

Two methods have been proposed for the gas leak tightness test: the pressure decay rate (PDR) and a novel one, the Flow Rate Loss (FRL). For both methods emulated Leak Branches (LB) have been used for their calibration. The gauge pressures have to be accurately measured by using digital differential manometers [7]. The prototype setup is shown in Fig. 1. Emulated leaks could be created using appropriate leak branches located close to the testing Module via a T-connector. In a first stage the LBs have to be tested experimentally by using the FRL method. By this test we can, primarily, validate and calibrate the LB and at the same time we can have quantitative estimate of the performance of the FRL method.

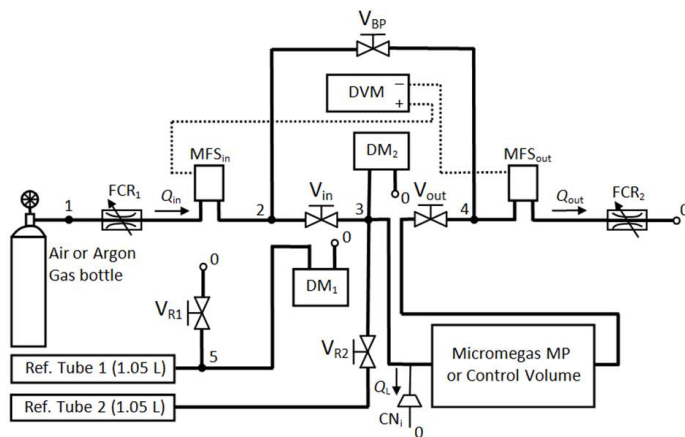

Fig. 1. The prototype setup for combined use of the PDR and the FRL methods. The abbreviations mean, MFS: mass flow sensor, DM: differential manometer, DVM: digital voltmeter, FCR: flow control regulator, CN_i: calibrated needle and V: valve [7].

By using the PDR method we obtained the pressure decay of the calibrated needle, i.e. type 31G-CN (Fig. 1), in conjunction with a well-tight reference tube having a volume of 1.05 L, while the atmospheric fluctuations have been compensated by using a differential manometer. By fitting a line to the first five data points we found the line equation, $p = -10.2t + 1.13$, the units used in the plot are second for time and mbar for pressure. The overall error in the slope is 10%. The same needles have also been used for measurements applying the FRL method. In the plot of Fig. 3, the flow rate in the inlet and outlet is shown. The small positive difference in flow rate corresponds to the leak rate loss. We underline the much

smaller lasting time (few seconds) of the FRL method compared with that of PDR method (about 10 min), Fig. 2.

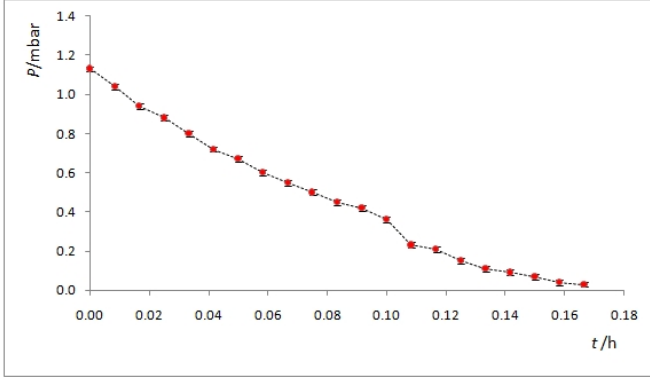

Fig. 2. Pressure decay plot obtained experimentally with the calibrated needle 31G-CN1, by the method PDR. A straight line has been fitted to the first five data points from 1 mbar and below for determining the leak rate [7].

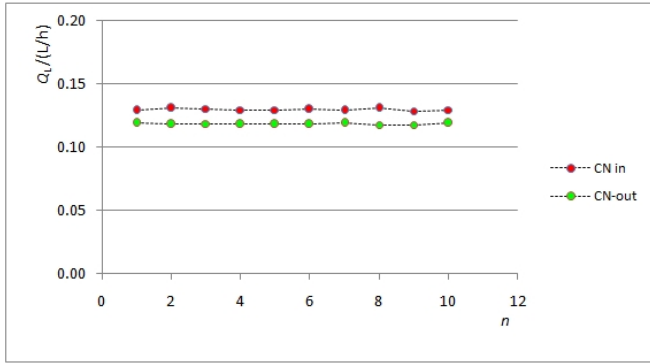

Fig. 3. The flow rates measured, by the method FRL, in the inlet and outlet by using the calibrated needle 31G-CN1 connected in the stream line [7].

In the FRL method the voltage output of the MFSs in the inlet and outlet are compared with and without the Micromegas Modules under study. The results by the methods, PDR and FRL, shown in the plots Fig. 2 and Fig. 3, respectively, are compatible within the corresponding errors [8].

In Fig. 4 a configuration of this method is shown [9]. Therefore, the leak rate loss, a positive quantity, is calculated according to the following formula:

$$Q_L = (Q_{in}^A - Q_{out}^A) - (Q_{in}^B - Q_{out}^B) = \frac{1}{b_1} (V_{0,in}^A - V_{0,out}^A) - \frac{1}{b_2} (V_{0,in}^B - V_{0,out}^B) = \frac{1}{b_1} \left[(V_{0,in}^A - V_{0,out}^A) - \frac{b_1}{b_2} (V_{0,in}^B - V_{0,out}^B) \right] \quad (1)$$

where, $V_{0,in}^A$, $V_{0,out}^A$ are the voltage output in the inlet and outlet if the branch A is used and $V_{0,in}^B$, $V_{0,out}^B$ if the branch B is used, respectively. But the fraction b_1/b_2 is related to the repeatability of the sensors and we can set $b_1 \approx b_2 = b$ in good approximation. Therefore, the last expression becomes:

$$Q_L = \frac{1}{b} (\Delta V_0^A - \Delta V_0^B) \quad (2)$$

The leak test using the FRL method can be implemented in the mass production in BB5. According to the FRL method, the first-basic configuration includes: two mass flow sensors (MFS) or other more precise mass flow meters, one in the input supply line of the Micromegas Quadruplet and the other in the output line. The ‘‘T’’ or ‘‘Y’’ connectors allow the flow deviation to a non-leaking part (‘‘tare’’ term) whose flow rate has to be subtracted. Three high-tightness shut-off valves have to be used to isolate alternatively the normal line and the bypass line.

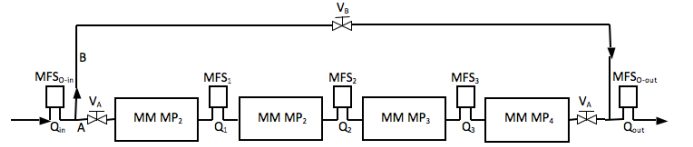

Fig. 4. The simple setup proposed to measure the tightness of four Micromegas Quadruplets simultaneously by using the FRL method [8].

In the next calculation the detection limit of the type of sensors already purchased for the gas distribution system is used. A straight line has been fitted to the data given by the manufacturer for argon for obtaining the calibration equation, $V_0 = bQ_0 + a$ where a and b are the two associated parameters which, in principle, could differ slightly between different mass flow sensors. The leak mass rate loss is expressed by the voltage output of the sensors. The corresponding volume flow rate Q is given by the manufacturer referring to standard conditions (1 bar, 0 °C) and of course we can convert it for different temperatures.

IV. LOCK-IN AMPLIFIER TECHNIQUE

The functionality of this method relies on the orthogonality of sinusoidal functions. The resulting mean value of sinusoidal functions of different frequencies, multiplied together, over a much longer time than the fundamental period, is zero. Instead, when their frequencies are equal and in phase, the result is the half of the product of the corresponding amplitudes.

For a sine-wave reference signal and an input waveform $V_s(t)$, the DC output signal $V_{out}(t)$ may be calculated in an analogue Lock-in Amplifier using:

$$V_{out}(t) = \frac{1}{T} \int_{t-T}^t \sin(2\pi f_r t + \varphi) V_s(t) dt \quad (3)$$

Where φ is a phase and T the integration time. The output is $V_{out}(t) = V_{L,out} \cos \theta$, where $V_{L,out}$ is the signal amplitude at the reference frequency and θ is the phase difference between the signal and reference. The signal $V_s(t)$ may contain superimposed noise components. However, their integration

tends to zero when T tends to ∞ . Furthermore, if the signal is periodic but arbitrary, in its Fourier expansion representation only the fundamental sinusoidal component with frequency equal to the reference can survive in the integration.

The Lock-in Amplifier (LIA) technique, when applied, includes two main steps [8], [10]: a) if it is required, to shift the signal spectrum to an appropriate frequency region where the noise is relatively small and b) to apply a coherent demodulation at a frequency equal to that of the modulated signal. During the second step process (b), only the noise components which are very close to the demodulation frequency remain. The resulting signal is the so-called Phase Sensitive Detector (PSD) output. According to this technique we need to make the lock-in frequency the same as the reference frequency. By using a low pass filter with roll-off frequency around ω_r the resulting signals should be the DC signal, which is the signal we measure, and the (unwanted) noise components with frequencies in a narrow region around ω_r . Therefore:

$$V_{PSD,X} = \frac{V_S V_L}{2} \cos[(\omega_r - \omega_L)t + \varphi_S - \varphi_R] - \frac{V_S V_L}{2} \cos[(\omega_r + \omega_L)t + \varphi_S + \varphi_R] + V_L n(t) \sin(\omega_L t + \varphi_R) \quad (4)$$

The lock-in reference needs to be phase-locked to the signal reference and therefore not only do the frequencies have to be the same, but also the phases. In such a case the obtained signal after passing the low pass filter is:

$$V_{PSD,X}^{LP} = \frac{V_S V_L}{2} \quad (5)$$

V. DUAL PHASE IMPLEMENTATION

The dc differential signal, associated with the FRL method, representing the gas leak rate, is modulated by two synchronized electronic choppers. The reproduced dc signal corresponds to the fundamental component in the Fourier expansion [8]. The setup is shown in Fig. 5.

The signal associated with the FRL method is a DC differential voltage originated by the outputs of the two mass flow sensors (in inlet and outlet respectively). The DC level of the differential signal depends on the leak rate and the gas used. The superimposed noise constitutes the intrinsic fluctuations of the repeated measurements of the flow rate by the mass flow sensors. The r.m.s. level of these fluctuations is of the order of 2.5 mV and depends slightly on the gas flow rate, as it is given by the manufacturer data sheet.

For argon in the flow stream and a leak rate around the acceptance limit of the Micromegas Quadruplets, is about 35 mV. Therefore, the S/N ratio is typically equal to 14. For the cases of much lower leak rates the S/N ratio might be close or less to unity. Our goal is to improve the S/N ratio of this differential signal as much as possible by using the LIA technique.

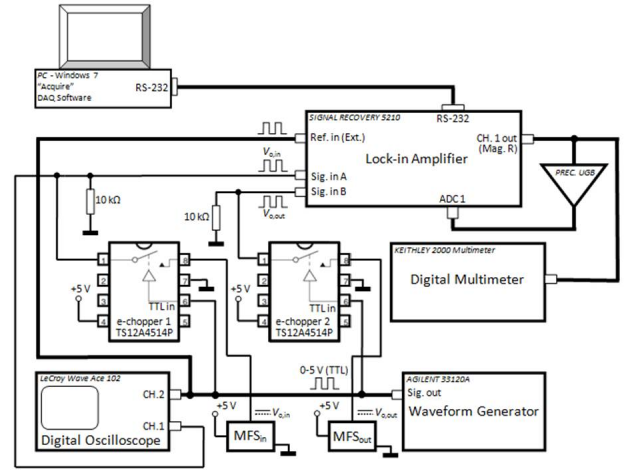

Fig. 5. The dc differential signal, representing the gas leak rate, is modulated by two synchronized electronic choppers. The reproduced dc signal corresponds to the fundamental component in the Fourier expansion [8].

VI. DATA ACQUISITION AND CONTROL

The gas tightness test has to be performed in a semi-automatic way and thus it needs appropriate data acquisition and control software. In Fig. 6 we present the baseline setup already installed in BB5 at CERN. In this setup we use the commercial “Acquire Data Acquisition Software” (ADAS) reading the four input ADC channels provided by the available in NTUA Lab 5210 LIA device [10], [11].

Nevertheless, even if the ADAS communication program seems to be able to cover the entire required signal recording we are developing a system based on WinCC-OA SCADA based on our experience acquired in DCS of ATLAS sub-detectors.

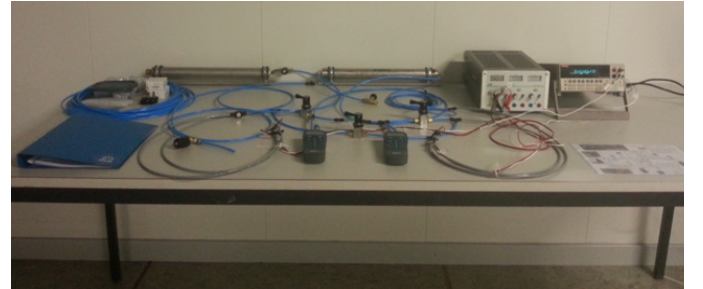

Fig 6 The initial-basic setup installed at BB5/CERN is shown. An upgraded setup is scheduled to be materialized, equipped by the LIA technique for improving the sensitivity of the gas leak measurements down to the level of 5×10^{-2} with respect to the acceptance limit set by NSW specifications.

By using the ADAS software we have performed a test of the system obtaining the gas leak rate using a needle of type 32G. We recorded the signals with and without the leak branch of the needle, as shown in Fig. 7. The two obtained histograms are completely separated and were fitted with Gaussians functions. The obtained results were as follows: voltage output $V_s = 4.26 \pm 0.25$ mV and the corresponding calculated gas flow rate $Q_L = 0.0140 \pm 0.0008$ L/h. This level of leak rate is

similar to that expected for the Micromegas Quadruplets [8][9].

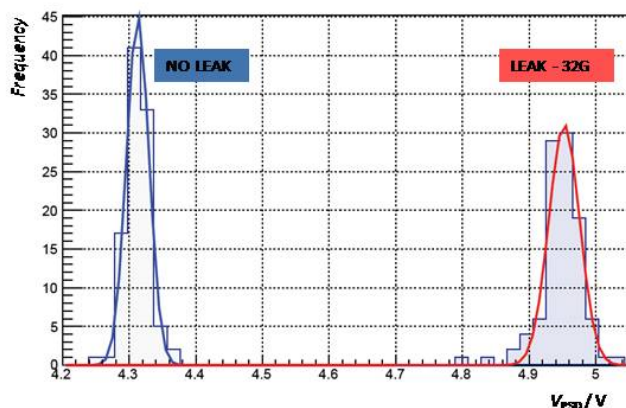

Fig. 7. Gaussian fittings of the obtained output signal distributions: the left without (tare measurement) and the right with leak branch (needle) connected.

VII. CONCLUSIONS

Advanced data processing and analysis techniques are being used in the gas tightness station at BB5/CERN aiming to contribute to the QA/QC of the NSW Micromegas Quadruplets. Two alternative and appropriate methods have been developed for this purpose; the Pressure Decay Rate and the Flow Rate Loss. The latter is much faster and insensible to the temperature and atmospheric pressure variations during the test.

A prototype setup based on the Lock-in Amplifier technique, and in conjunction with the Flow Rate Loss method, has been tested evaluated and calibrated using specific medical needles. A semi-automatic data acquisition and control system is used in the baseline setup. The development of a more sophisticated software environment, by using the WinCC-OA SCADA system is in progress.

VIII. REFERENCES

- [1] ATLAS Collaboration, J. Instrum. 3 (2008) S08003.
- [2] LHC Collaboration, J. Instrum. 3 (2008) S08001
- [3] ATLAS Collaboration, ATLAS New Small Wheel TDR, CERN-LHCC-2013-006 ATLAS-TDR-020-2013.
- [4] Y. Giomataris, P. Rebourgeard, J.P. Robert, G. Charpak, NIM Physics Research Section A 376 (1996) 29.
- [5] ATLAS Collaboration. Technical Design Report for the Phase-I Upgrade of the ATLAS TDAQ System. CERN-LHCC-2013-018. ATLAS-TDR-023. Geneva: CERN, Sept. 2013.
- [6] T. Alexopoulos, et al., NIM A 640, 110-118, (2011).
- [7] T. Alexopoulos, et al., "Investigation of Gas Leak Test Methods for the NSW Micromegas 4 Multiplets Mass Production", ATLAS NOTE to be published
C. J. Kaufman, Rocky Mountain Research Laboratories, Boulder, CO, personal communication, 1992.
- [8] T. Alexopoulos, et al., "Gas Leak Test Prototype Setup for the NSW Micromegas Multiplets Implementation and Calibration Technique", ATLAS NOTE to be published
- [9] T. Alexopoulos, et al., "Design of NSW Gas Distribution System for Micromegas Detectors", ATLAS NOTE to be published
- [10] SIGNAL RECOVERY, "What is a Lock-in Amplifier?", Technical Note TN 1000.
- [11] SIGNAL RECOVERY, "Specifying Lock-in Amplifiers", Technical Note TN 1001.