

EE

C1

CERN SL/91-25 (BI)

CERN LIBRARIES, GENEVA



CM-P00061055

THE LEP SYNCHROTRON LIGHT MONITORS

C. Bovet, G. Burtin, R.J. Colchester, B. Halvarsson, R. Jung, S. Levitt, J.M. Vouillot

Abstract

Four monitors are installed in LEP, two per particle type. Two of the monitors are at dispersion free locations which permit measurement of the transverse emittance, estimation of the energy spread and detection of various instabilities. The light has its origin in the main bending magnets. The source is imaged onto the detectors by means of catadioptric optics. Two detectors are used, one a CCD matrix and the other made up of a fast optoelectronic shutter and wavelength shifter coupled to a CCD matrix. Observations can either be made in the normal TV mode or in digital modes where one or more profiles (burst mode) are stored on the CCD and then digitized in 12 bit ADC's. In the burst mode, up to 18 profiles separated by 1 to 256 turns can be acquired. The results are either presented as data mixed with the TV picture or as two or three dimensional plots and projections on a workstation. Results and present performance are presented.

*Extended version of the paper presented at the 1991 IEEE Particle Accelerator Conference,
San Francisco, May 6-9th, 1991*

Geneva, 30th April 1991

THE LEP SYNCHROTRON LIGHT MONITORS

C.Bovet, G. Burtin, R.J. Colchester, B. Halvarsson, R. Jung, S. Levitt, J.M. Vouillot
 European Organization for Nuclear Research (CERN)
 CH-1211 Geneva 23, Switzerland.

Abstract

Four monitors are installed in LEP, two per particle type. Two of the monitors are at dispersion free locations which permit measurement of the transverse emittance, estimation of the energy spread and detection of various instabilities. The light has its origin in the main bending magnets. The source is imaged onto the detectors by means of catadioptric optics. Two detectors are used, one a CCD matrix and the other made up of a fast optoelectronic shutter and wavelength shifter coupled to a CCD matrix. Observations can either be made in the normal TV mode or in digital modes where one or more profiles (burst mode) are stored on the CCD and then digitized in 12 bit ADC's. In the burst mode, up to 18 profiles separated by 1 to 256 turns can be acquired. The results are either presented as data mixed with the TV picture or as two or three dimensional plots and projections on a workstation. Results and present performance are presented.

1. MONITOR LAYOUT

Four synchrotron light monitors are installed around intersection point 8. The light originates in the bending magnets at points close to defocusing quadrupoles in order to have maximum vertical beam dimensions. These quadrupoles are also equipped with position monitors. The first two telescopes on each side of the intersection observe a near dispersion free section, whereas the two others are located where the dispersion is large. This set-up permits the measurement of transverse emittances and an estimation of the energy dispersion.

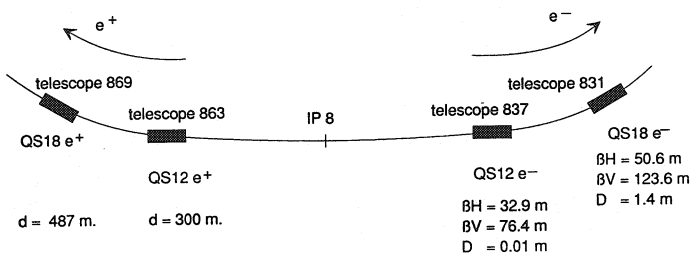

Fig. 1 : Synchrotron Light Monitor locations.

The four bunches in each beam are separated by 22 μ s. The relevant beam optics parameters are given in Fig. 1. The nominal beam parameters for LEP phase 1 are a maximum beam energy of 50 GeV, a stored current of 3 mA per beam, and at 46 GeV a horizontal emittance of 41.9 nm, a vertical emittance of 1.68 nm and an energy dispersion of 0.766 per mill.

2. PRINCIPLE OF OPERATION

A schematic view of a monitor is given in Fig.2. In order not to interfere with the circulating beams, the light extraction mirrors are located outside the nominal horizontal vacuum chamber acceptance of 131 mm. This leads to a light origin to mirror distance of 21.72 m, for a 20 mm wide mirror, which is slightly smaller than the length of a four bending magnet string (23.44 m). To make room for the synchrotron light, the vacuum chamber preceding the extraction mirror has been enlarged in the last bending magnet to a width of 159 mm. Calculations of the deformation due to thermal loading have imposed the use of a beryllium mirror in order to keep the surface irregularities within acceptable limits. With a 10 mm thick mirror, the original plane mirror is deformed into a spherical mirror of 700 m focal length with irregularities with respect to the sphere of 20 to 50 nm. The beryllium mirror is 23 mm high in order to fit into the available space. One of the main limitations of the monitors is the diffraction which increases with the light wavelength, therefore the shortest possible wavelength should be used for the profile measurements. The possibility of measuring profiles at various wavelengths for estimating the diffraction broadening is foreseen. The shortest wavelength is first limited by the extraction window separating the LEP vacuum from the outside. With a quartz window, this lower limit is fixed at 180 nm. The upper limit is determined by the detector and is equal to 1100 nm for the CCD detector used. This large domain led to the use of a catadioptric system which provides an achromatic focusing over the whole spectrum.

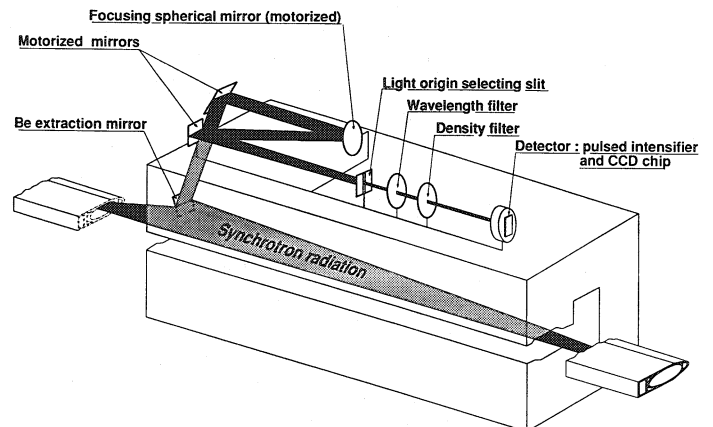

Fig. 2 : Schematic view of the LEP synchrotron light monitor.

Only the parallel polarization component of the light should be used for obtaining the best resolution. The vertical component is discarded by a combination of two metallic mirrors. The best combination fitting in the available space made use of the beryllium extraction mirror and a chromium coated mirror with incidence angles at the mirrors of 31° and 59° . This arrangement attenuates the power from the perpendicular polarization to about 5% of the total and brings the light back into the horizontal plane on top of the bending magnet. Next to diffraction, the longitudinal acceptance will limit the precision of the profile measurements through defocusing and, in the horizontal plane, orbit sagitta. These effects can be controlled by limiting the angular acceptance in the horizontal plane, which is best achieved by using a horizontal slit at the focal plane of the focusing mirror. This can be seen easily in the phase-space plot of Fig. 3. This phase-space has been described in [1], and the drawing is made at the nominal light origin. The horizontal axis is the horizontal beam position and the vertical axis is the horizontal angular deflection. The beam trajectory is a parabola, the extraction mirror is transformed in a skewed band and the slit in the focal plane is a horizontal acceptance band. As can be seen in the sketch, the longitudinal limits set by the slit are independent of orbit position changes, which would not be the case with a diaphragm located at any other position. This slit does not generate a vertical diffraction pattern which is a great advantage. The vertical diffraction will only result from the natural diffraction of the synchrotron light pattern and from the limitations in the vertical plane set by the extraction mirror.

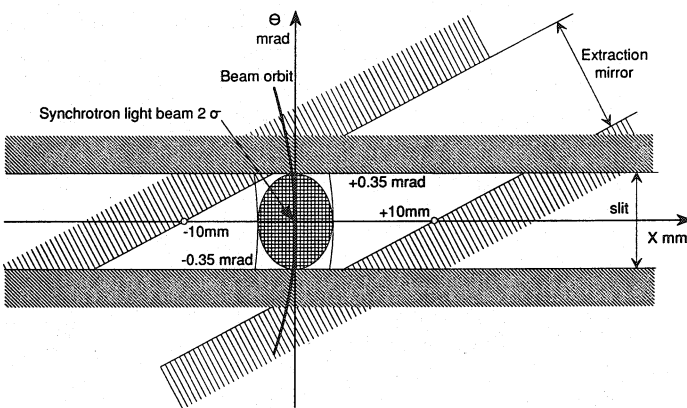

Fig. 3 : Horizontal phase-space plot of the synchrotron light monitor.

CCD frame transfer detectors are used. Their well defined geometry and control flexibility makes them very attractive for this application. Their main disadvantage is the lower cut-off wavelength of 450 nm which leads to the use of a wavelength shifter. The latter is included in a fast optoelectronic shutter enabling the separation of individual bunches and the choice of predetermined observation times.

3. SYSTEM DESCRIPTION

The enlarged vacuum chamber is connected to a small light extraction tank which takes the place of the hydroformed bellows used between adjacent chambers. The tank has a length of either 202 mm or 300 mm depending if it is at the QS 18 or QS 12 monitor. The tank is made of a machined and water-cooled copper piece to which a bellows is brazed to give some degree of freedom with respect to the adjacent chambers. Also brazed to it are the light extraction tube and the passage for the beryllium mirror. This tank will absorb most of the incoming synchrotron radiation power, i.e. 130 W in LEP phase 1. It provides as smooth a transition as possible between the two vacuum chamber sections. The light extraction tube, including the pieces up to the telescope, acts as a waveguide below cut-off for the electromagnetic fields induced by the beam. This keeps the RF losses of the set-up at a reasonable value. The beryllium mirror is tightly fixed onto a water cooled support and can be retracted from the light path if necessary. The mirror assembly is mounted on the telescope tube for maximum stability. A compensating bellows takes any stress from the telescope tube. The telescope itself is mounted in a stainless steel tube of 350 mm inner diameter and 3.44 m length. This tube is located above the bending magnet and rests on a stable support made of I shaped aluminium beams. The optical elements and the detectors are fixed on a 3.2 m long optical bench. As mentioned previously, the first folding mirror is chromium coated. The two other mirrors are aluminium coated for maximum reflectivity down to the UV domain. The incidence angle on the focusing mirror has been kept to less than 2 degrees to minimize the astigmatism. The focal length of this mirror is 4.04 m, which is a compromise between available length and magnification. The magnification of the telescope is $G = 0.2$. The first two mirrors can be rotated around the horizontal axis and the third mirror around the vertical axis to center the light spot on the detectors. Two sets of seven chromatic and seven density filters allow the choice of the wavelength used and adjustment of the light intensity to the dynamic range of the detectors. At present, filters centered around 480, 450, 253 nm are used for measuring the profiles, and filters centered around 622 and 800 nm are used to assess the contribution of the diffraction to the profile enlargements. Six density filters are available with transmissions from 100 to 1 %. The light origin selecting slit can be varied in aperture from 0 to 10 mm in 0.1 mm steps, adjusting the angular acceptance from 0 to ± 1.25 mrad. Its center can be adjusted in the same way within ± 5 mm. Two detectors are installed, either the light is focused directly on the entrance face of the wavelength shifter/fast shutter assembly, or it is deflected via a movable mirror/camera assembly [2] directly onto a CCD chip. All movements are made via stepping motors. The elements were first aligned in a surface laboratory and then again during the installation in the tunnel. The final tuning was made with the LEP beams.

The elements in the telescopes are remotely controlled via the LEP control system (Fig. 4). Two VME crates (ECA's) located in an underground cavern at about 500 m from the telescopes are used to control and read data from the four telescopes. The VME crates each house a 68010 CPU, communications and timing modules, stepping motor controllers, camera mode controllers and image acquisition cards. The software is written in Pascal and C using the RMS68K operating system. Image acquisition and processing is performed on request, at a user-defined frequency or on external events. Apollo workstations are used to display the results and images in the PCR (Prévessin Control Room). A menu-driven program for the PCA's gives complete test facilities, and can be used to display the two dimensional images and projections.

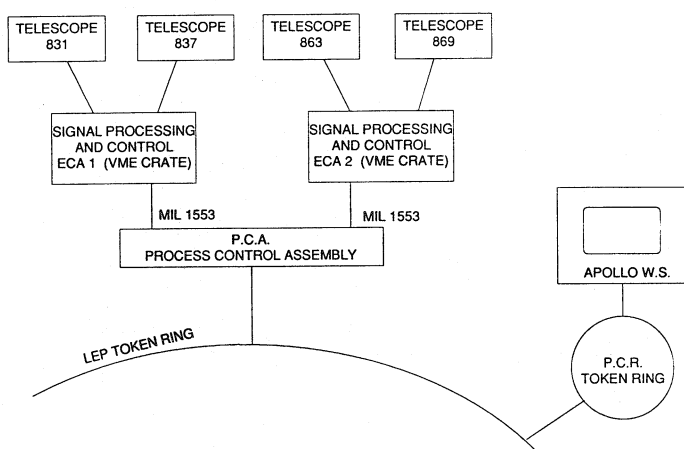

Fig. 4 : System control chain.

4. DETECTORS

The CCD chip [3] consists of 110'000 useful light sensitive pixels, each 23 μ m square, arranged in 288 rows of 384 columns, the spectral response of the CCD extends from 450 to 1100 nm. The CCD is of the frame transfer type meaning that there are two active areas on the chip, one area (image zone) is used to acquire the new data whilst the second area (memory zone) is used to read out the previously acquired data. Transfer between the two zones occurs at the end of each integration period and takes 0.16 ms. The linear dynamic range of the CCD is greater than 1:700.

The CCD control electronics have been designed to give complete control of the integration and readout times of the chip. In the simplest mode of operation the CCD operates as a conventional TV camera with an integration time of 20 ms. In the normal digital operation mode the integration time can be varied from 100 μ s to 65 ms and the pixels can be read out at a rate of 1 MHz, rate dictated by the ADC used. The start of the integration time can be synchronized to an external event. In these two modes of operation the complete image area of 288 rows is shifted to the memory zone for readout when the integration time has elapsed. The third and

most complex operational mode of the detector is the "multi-image" or "burst" mode. In this mode, the image area is shifted to the memory zone in discrete blocks during the acquisition time, these blocks consist of a preselected number of rows (from 16 to 128). By using this block shifting technique, in conjunction with the external fast electronic shutter, up to 18 images can be stored in the CCD during one acquisition period. The external shutter and the shifting of the pixel rows have to be synchronized to each other. There is a dead time between exposures of about 25 μ s for 8 exposures. The readout of the memory zone is done in the same way as described previously.

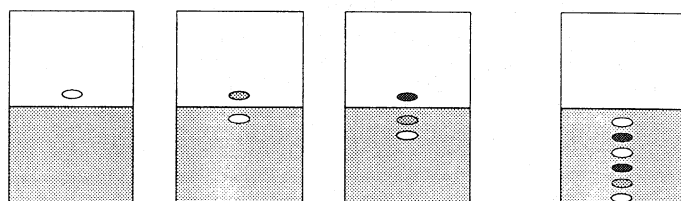

Fig. 5 : "Burst mode": The top zone is the image area on which the synchrotron light is imaged. The shaded zone is the memory area. Between successive light pulses, controlled by the fast shutter, the stored profiles are shifted down to the memory area. At the end of the process up to eighteen profiles (six illustrated) are stored in the memory area of the CCD.

The wavelength converter/shutter is a commercial product [4]. It consists of a two stage image intensifier with a magnification of 11/18. The input window is made of quartz and the photocathode is sensitive from below 180 nm up to 300 nm. The phosphor radiates at 520 nm and has a fast decay time of 100 ns to be compatible with the burst mode. The high voltage (5 to 10 kV) to the intensifier is pulsed so that the device behaves as an electronic shutter with a rise/fall time of a few microseconds and an open time of about 10 μ s. The intensifier is directly coupled to the CCD chip via a fiberoptic bundle. The pulsing interval can be adjusted from 1 to 256 beam turns and can be locked onto any of the four circulating bunches.

5. DATA ACQUISITION AND PROCESSING

The CCD memory area is digitized with a 12 bit fast (1 MHz) ADC and the result is stored in an on-board buffer memory. Once the image has been acquired, an area of interest is found by scanning every fourth pixel on every fourth row to find the highest value, a rough measurement of the half height is used to define the dimensions of this area in both planes. Projections are then done within this area by summing every row to get the horizontal profile, and every column for the vertical profile. The profiles are corrected for thermal drift by subtracting the straight line between the endpoints of the area and a smoothing of the profiles is also done. The profiles are measured using a three pass

calculation. Once the measurement is complete, the results, profiles and the sixty by sixty pixel portion of the image around the centre of charge are stored in a buffer, ready to be read by the PCA. The measured sigmas and their average and rms values over a predetermined number of measurements are superimposed on the TV picture via a commercial text generator and mixer card.

6. RESULTS WITH BEAM

As soon as sufficient current was circulating in LEP in July 1989, the synchrotron light monitors received their final tuning and were used in TV mode. They were very useful for real time observation of the beam size, coupling and various instabilities. This was mainly due to their good sensitivity as 1 μ A beams were visible. Later in the year the images were digitized and the beam profile measuring algorithms tested. This information was then added to the TV picture. This is still the most used facility provided by the monitors. In 1990 software was written for the PCR workstations and the fast shutters were tested. The 3-D plots proved to be extremely useful for the fine tuning of the instruments. The precision of the monitor began to be evaluated over the five months of operation. The linearity of the monitors was checked and found good to 3% over two decades of intensity. The contribution of the slit width w_s was investigated and it was confirmed that for the measurement of the horizontal emittance there is an optimum slit opening around 3 mm where the combined contributions from the longitudinal acceptance and the diffraction are minimum. For the vertical emittance the best result is obtained with the smallest possible slit, a practical limit being around 0.5 mm. The variation of the beam rms values were measured as a function of the wavelength and the contribution of the diffraction evaluated. These various contributions can be considered as an rms broadening which will add quadratically to the beam size. The estimated values, given in μ m, are:

$$\begin{aligned}\sigma_{Dh} &= 2 \lambda / w_s, \text{ for the horizontal diffraction,} \\ \sigma_{Dv} &= 4 \lambda^{2/3}, \text{ for the vertical diffraction,} \\ \sigma_{LA} &= 70 w_s, \text{ for the longitudinal acceptance,}\end{aligned}$$

λ being expressed in nm and w_s in mm.

No measurable difference could be observed between the horizontal and vertical broadenings due to the longitudinal acceptance (slit width). Further studies are needed to improve the precision of these estimations.

The fast shutter was operated in TV, digital full frame and digital burst modes. Below is the resulting 3-D plot of eight successive turns of the same bunch. The program gave also the plot of the centres of charge as well as various displays for the individual shots.

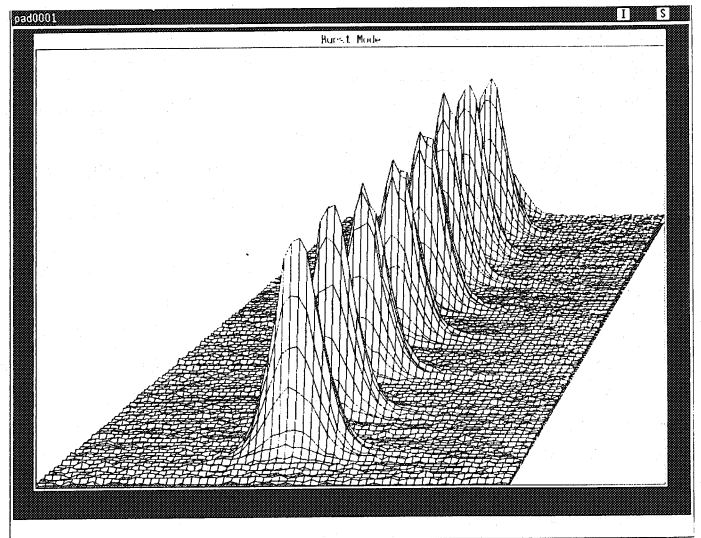

Fig. 6 : 3-D plot of eight successive turns of a selected bunch. The horizontal axis is the beam horizontal dimension, the other axis is the vertical beam axis within a time slot.

ACKNOWLEDGEMENTS

Acknowledgements are due to the many colleagues in the MT Design Office and Workshops, with a special mention to R. Perret, who have greatly contributed to the realization of these monitors.

REFERENCES

- [1] A.P. Sabersky : The geometry and optics of synchrotron radiation, Particle Accelerators, 1973, Vol. 5, pp199-206.
- [2] G. Burtin et al. : The Lep injection monitors : design and first results with beam, CERN/LEP-BI/89-06, March 1989, and Proc. of the 1989 IEEE Acc. Conf., Chicago.
- [3] CCD chip TH7863, Thomson, France.
- [4] Proxifier BV 2502 Cc X15 & BV 1811 KX, Proxitronic, Bensheim, Germany.

APPENDIX

This paper was presented as a poster at the 1991 IEEE Particle Accelerator Conference in San Francisco. Given below are the most relevant illustrations which figured on the poster but could not be included in the limited space available for the proceedings.

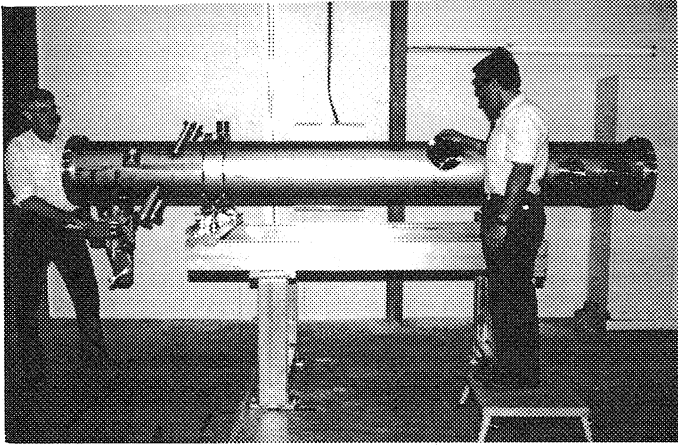

The telescope ready for installation in the LEP tunnel

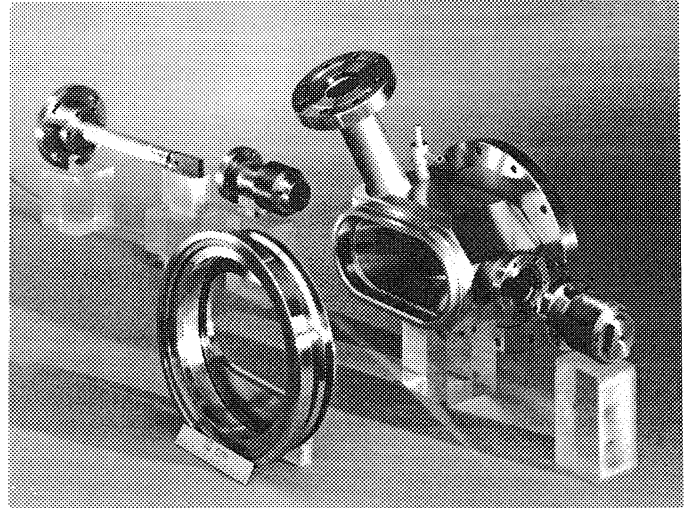

Components of the light extraction system. The beryllium mirror can be seen at the top left hand side.

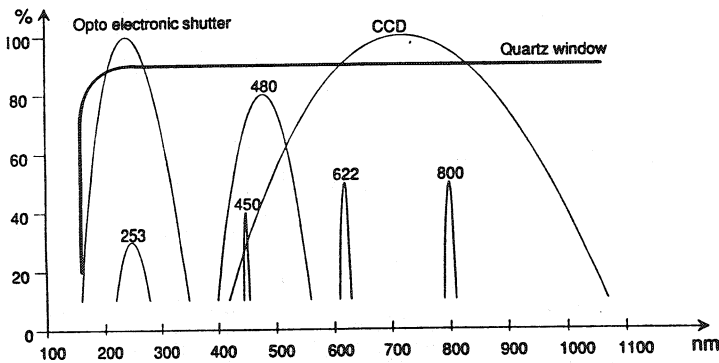

Filters and detectors wavelength characteristics. The light transmission or sensitivity for each element in the system is plotted against wavelength in nanometers.

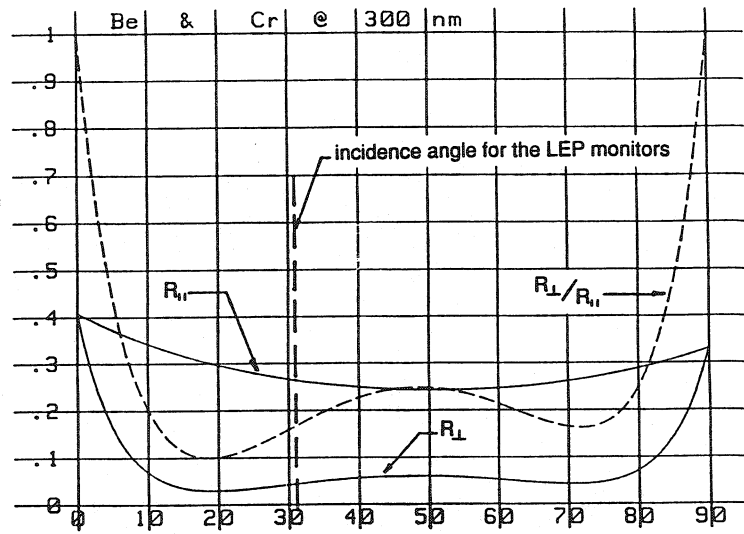

Reflection coefficients for the vertical and horizontal polarization components of the synchrotron radiation and their ratio as a function of the incidence angle on the beryllium mirror.

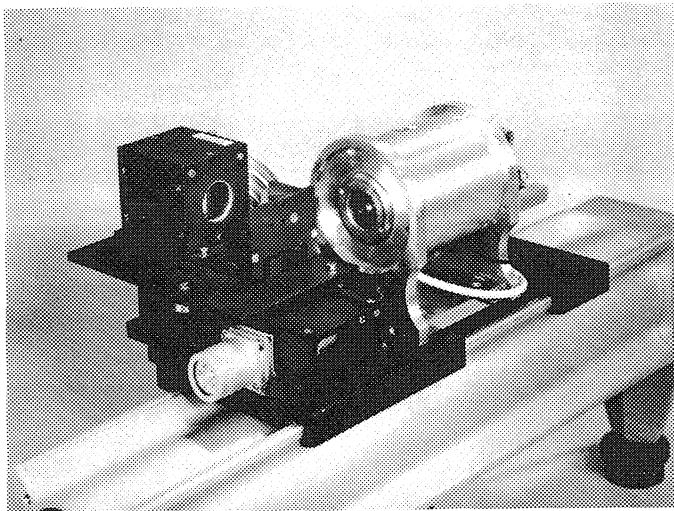

The two detectors - the normal CCD camera (left) and the UV converter/shutter with its CCD chip.

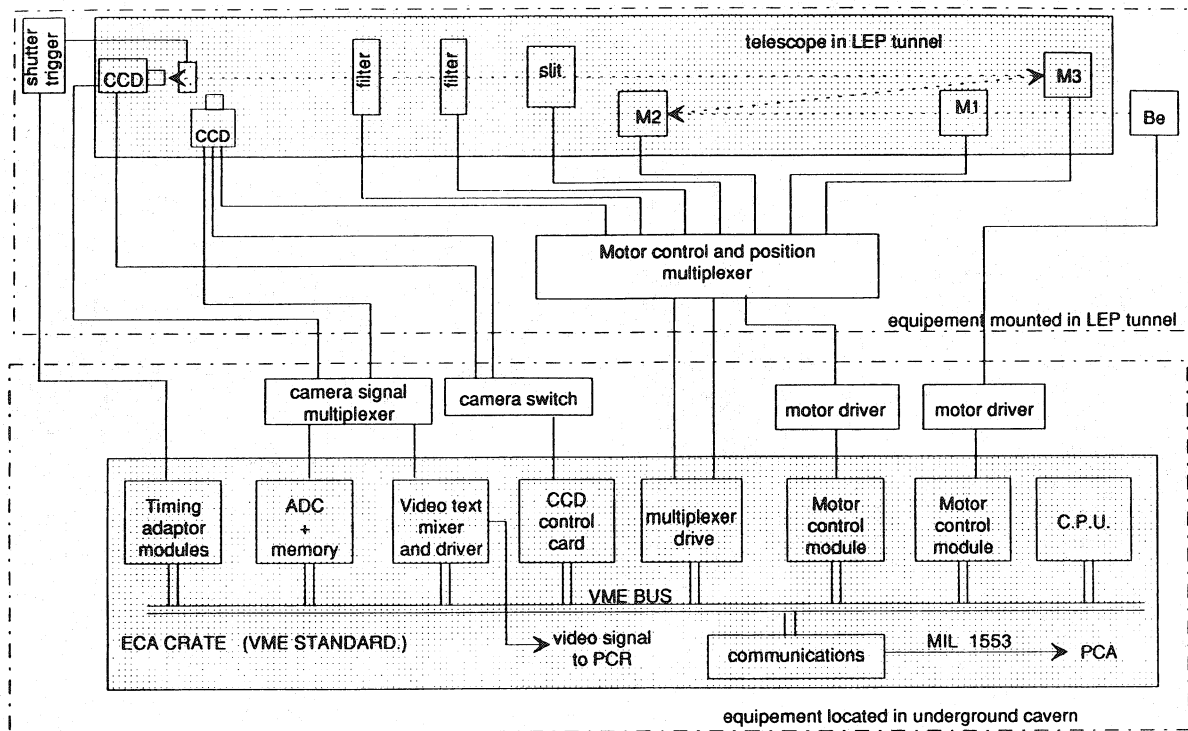

The Synchrotron Radiation profile monitor block diagram.

The elements in the telescope are remotely controlled via the LEP controls system through local VME crates.

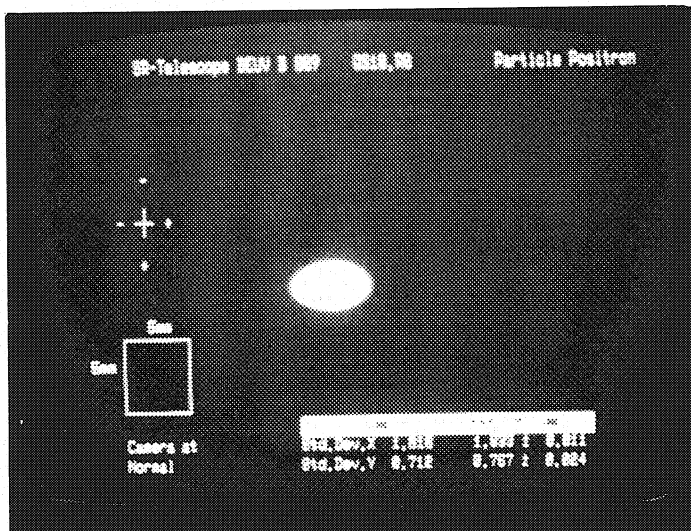

A circulating beam as seen on the TV display in the PCR. The telescope location, particle type and standard deviation of the beam sizes (last and averaged measurements) are also displayed.

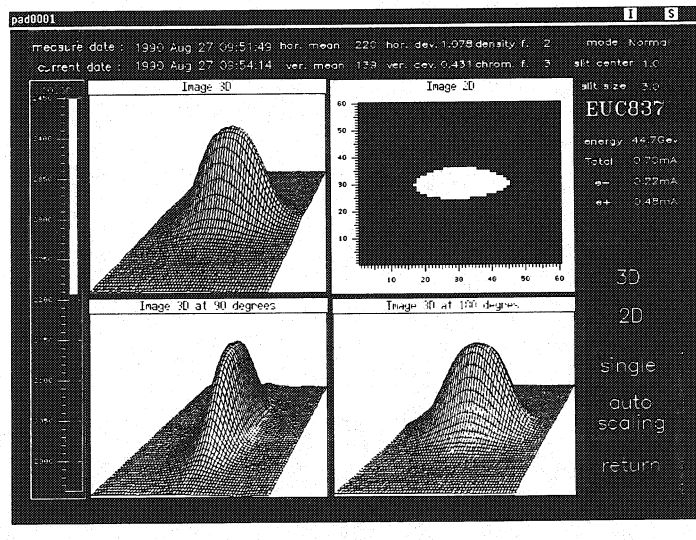

2D and 3D image plots and profiles of a circulating beam displayed on a workstation.