

First operation of the level-0 trigger of the NA62 liquid krypton calorimeter

This content has been downloaded from IOPscience. Please scroll down to see the full text.

2015 JINST 10 C03050

(<http://iopscience.iop.org/1748-0221/10/03/C03050>)

View [the table of contents for this issue](#), or go to the [journal homepage](#) for more

Download details:

IP Address: 131.169.4.70

This content was downloaded on 11/01/2016 at 22:36

Please note that [terms and conditions apply](#).

TOPICAL WORKSHOP ON ELECTRONICS FOR PARTICLE PHYSICS 2014,
22–26 SEPTEMBER 2014,
AIX EN PROVENCE, FRANCE

First operation of the level-0 trigger of the NA62 liquid krypton calorimeter

M. Barbanera,^{c,e} M. Bizzarri,^b V. Bonaiuto,^d B. Checcucci,^e P. Cipollone,^f
N. De Simone,^{d,1} R. Fantechi,^g L. Federici,^d A. Fucci,^f M. Lupi,^{c,e} G. Paoluzzi,^f
A. Papi,^e A. Salamon,^f G. Salina,^f C. Santoni,^b F. Sargeni^d and S. Venditti^g

^aDepartment of Physics, University of Rome “Tor Vergata”,
via della Ricerca Scientifica 1, Rome, Italy

^bDepartment of Physics, University of Perugia,
via Alessandro Pascoli, Perugia, Italy

^cDepartment of Electronic Engineering, University of Perugia,
via Goffredo Duranti, Perugia, Italy

^dDepartment of Electronic Engineering, University of Rome “Tor Vergata”,
via del Politecnico 1, Rome, Italy

^eINFN — Sezione di Perugia,
via Alessandro Pascoli, Perugia, Italy

^fINFN - Sezione di Roma “Tor Vergata”,
via della Ricerca Scientifica 1, Rome, Italy

^gCERN, Geneva, Switzerland

E-mail: nico.desimone@cern.ch

ABSTRACT: The NA62 experiment at CERN Super Proton Synchrotron aims at studying ultra-rare decays of charged kaons for precise tests of the Standard Model. The complete experimental setup is being commissioned for the first physics data taking in the autumn of 2014. This paper presents the final design and implementation of the Level-0 trigger system of the LKr calorimeter, acting as hermetic photon veto of the experiment in the 1-8.5 mrad region. The first on-field performance tests are presented.

KEYWORDS: Trigger concepts and systems (hardware and software); Trigger algorithms; Digital electronic circuits; Calorimeters

¹Corresponding author.

Contents

1	Introduction	1
2	Trigger and data acquisition system	1
3	The LKr calorimeter and the CREAM readout modules	2
4	The LKr Level-0 trigger	2
4.1	TELDES input board	4
4.2	Peak recognition firmware	4
4.2.1	Fine-time and energy resolution of the readout system	7
4.3	The internal transmitter and receiver mezzanines	7
4.3.1	Firmware interface and test results	9
5	Discussion and conclusion	9

1 Introduction

The NA62 experiment [1, 4], located in the CERN North Area, is especially focused on a precise measurement of the branching ratio of the very rare kaon decay $K^+ \rightarrow \pi^+ \nu \bar{\nu}$ [2, 3]. The 400 GeV/c high-intensity SPS proton beam impinges on a beryllium target and secondary kaons, with selected momentum of 75 GeV/c, decay in flight along the 65 m fiducial decay region (figure 1). Because of the small signature of the processes under study, various detectors, distributed along a 170 m long region, are devoted to particle identification and to the high precision measurement of the various physical quantities. An hermetic photon veto system is needed to reject photons from the various K^+ decay modes, in particular $K^+ \rightarrow \pi^+ \pi^0$, and the Liquid Krypton (LKr) calorimeter is used for such purpose in the 1–8.5 mrad forward region.

2 Trigger and data acquisition system

In the 2015 run the CERN SPS will provide 3×10^{12} protons per spill (4.8 s burst duration with a period of 16.8 s). At the time of writing, October 2014, the experiment is undergoing a first physics test run with a lower intensity beam. At full intensity, the selected 75 GeV/c secondary hadron beam will result in an instantaneous kaon rate of about 50 MHz and an average 10 MHz decay rate hitting the downstream detectors. In order to extract few interesting decays from such an intense flux, a complex and performing three level trigger and data acquisition system was designed [5].

The Level-0 (L0) trigger algorithm is based on few sub-detectors (the charged hodoscope, the muon detector, the liquid krypton electromagnetic calorimeter and large-angle vetoes) and it is performed by dedicated custom hardware modules, with a maximum output rate of 1 MHz and a maximum latency of 1 ms.

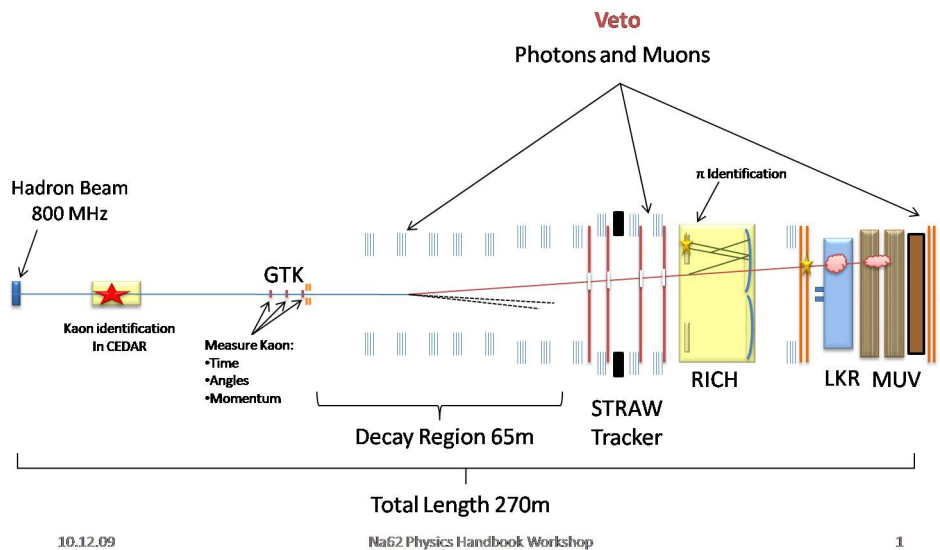

Figure 1. Schematic view of the NA62 detector.

The data from each sub-detector — except the LKr calorimeter’s — is sent to a farm of PCs where the Level 1 (L1) and Level 2 (L2) software triggers are performed. L1 algorithms run on the data of individual detectors. A positive L1 decision triggers the readout of the calorimeter data (which is kept in memories up to then) and, subsequently, L2 algorithms are executed on the complete event. The L1 trigger has a maximum output rate of 100 kHz with a non-fixed total latency of about 1 s, while the L2 trigger, has an output rate of the order of 15 kHz with a maximum total latency equal to the basic data taking time unit, the period of the SPS beam-delivery cycle.

3 The LKr calorimeter and the CREAM readout modules

The NA48/62 calorimeter [6] is a quasi-homogeneous ionization device, about 27 radiation lengths, segmented transversally (there is no segmentation in depth) to the beam in 13248 (2×2) cm² cells of thin copper-beryllium ribbons, kept at high voltage, and immersed in a 10 m³ liquid krypton bath at 120 K acting as active medium. For photons of more than 10 GeV energy, a detection inefficiency of 10^{-5} , a time resolution of 350 ps and an energy resolution of less than 5% allow its use as an efficient veto and for particle identification.

The back-end electronics has been updated from NA48 because of the higher trigger rate. New Calorimeter REadout Modules (CREAMs) [7] readout the calorimeter channels, buffer and optionally zero-suppress data during the SPS spill. They also provide to the Level 0 Trigger system (the object of this paper) 864 lower-granularity Trigger Level Sums (TLS): digital sums of 16 (4x4) calorimeter cells. A scheme of the calorimeter trigger and readout system is shown in figure 2.

4 The LKr Level-0 trigger

The Level-0 trigger of the LKr calorimeter (figure 4) is based on the recognition of the electromagnetic clusters and it is able to provide their position, fine-time and energy for a veto decision [10, 11]. Because the input of the trigger is the 864 TLS from the CREAMs, digital sums of

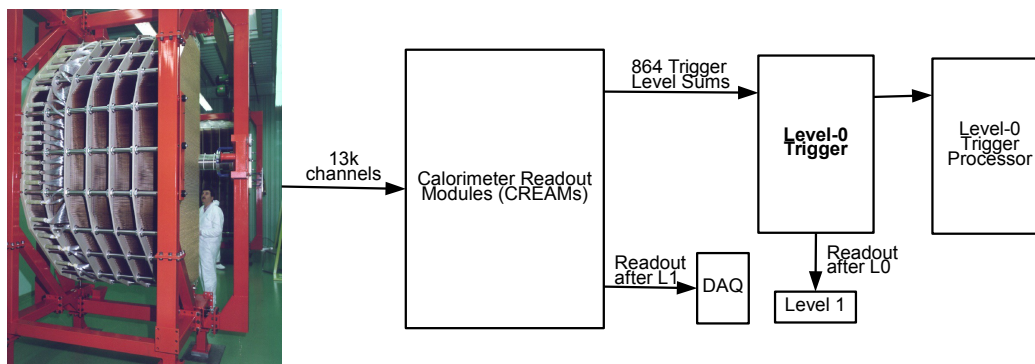

Figure 2. Schematic view of the LKr trigger and readout system. The 13248 analogue channels of the calorimeter are digitized from the CREAMs and buffered for the trigger L1 decision. 864 sums of 16 calorimeter cells each are sent to the L0 trigger that elaborates the data and sends trigger primitives to the central L0 Trigger Processor for the L0 decision.

4×4 calorimeter cells, the system reconstructs the position with the same bi-dimensional segmentation of the calorimeter but with a lower granularity of $(8 \times 8) \text{ cm}^2$.

The design parameters of the system are the maximum expected instantaneous hit rate of 30 MHz, the required single cluster time resolution of 1.5 ns and the maximum allowed latency of $100 \mu\text{s}$ from the detector hit generation to the trigger primitives output to the L0 Trigger Processor (L0TP).

The entire system will be composed by 36 TEL62 [8, 9], the 9U general purpose data acquisition board common to most sub-detectors of the experiment, equipped with custom dedicated I/O mezzanines. Each TEL62 provides four *Pre-Processing* FPGAs, receiving data from different kinds of custom receiver mezzanines, and one *Sync-Link* FPGA (all Altera Stratix III [12]) that collects the data and transmits it through a custom transmission mezzanine and eventually, via Gigabit Ethernet, to the L0TP.

The cluster search is performed through a 1D+1D algorithm on a 3-layer system as shown in figure 3:

- A *front-end* layer, composed of 28 boards (figure 4(a)), receives the TLS data from the CREAMs: each board reads up to 32 channels¹ (blue squares in figure 3) that are located along a vertical slice of the calorimeter. Peaks in the energy deposit are independently identified in each vertical slice (see 4.2).
- A 1st *concentrator* layer, composed of 7 boards (figure 4(b)), receives data from the *front-end* layer. Peaks on different vertical slices are horizontally merged when they are close in time and space, therefore each cluster is fully reconstructed. Each of the 7 boards has a region of interest of 4 vertical slices plus two slices on the left and two on the right (red area in figure 3), overlapping with neighbor boards, to avoid double counting.
- A final 2nd *concentrator* layer (figure 4(c)) with one board collects all the information and transmits, via Gbit Ethernet, a trigger primitive to the central L0TP for the trigger decision.

¹Because of the geometry of the calorimeter, each front-end board reads 32 channels from the central slices of the calorimeter and a smaller number from the edges of the calorimeter, for a total of 864 channels.

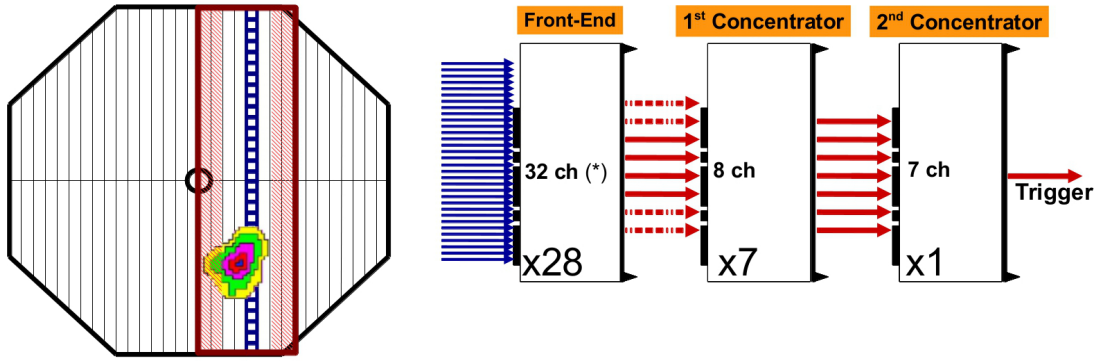

Figure 3. The segmentation of the LKr calorimeter trigger. The front-end layer is composed by 28 boards, each receiving from the CREAMs up to 32 TLS (1 TLS is represented with a blue square) providing the digitized energy deposit along a vertical slice of the calorimeter. Each board independently identifies peaks in the energy deposit along one vertical slice. A cluster may deposit energy over many vertical slices and the peak merging is performed on the 7 TEL62s of the 1st concentrator layer. Each of them spans a region (in red in the picture) of 4 vertical slices plus 2 left and 2 right to avoid double counting. The final concentrator board is used to provide trigger signal to the Level-0 Trigger Processor.

In the 2014 physics test run, a reduced system has been installed with six boards in the first layer, receiving data from the six central vertical slices of the calorimeter, and one concentrator board, that collects the peaks from the front-end boards, merges them into clusters and sends the result to the L0TP.

In the following sections hardware and firmware of each layer are briefly described.

4.1 TELDES input board

Each of the front-end TEL62 of the trigger system mounts two input mezzanines TEL62 DESerializer (TELDES, shown in figure 6), making a total of 56 TELDES in the whole system. Each TELDES receives 16 16-bit serial streams by the CREAMs. The stream is serialized by the SerDes circuitry built in the FPGA on-board each CREAM with the experiment master clock (TTC) at 40 MHz and deserialized by SerDes chips DS92LV16 on board the TELDES. It has embedded clock information, therefore avoiding any need for clock-data deskew. The physical links are 100 Ω differential pairs over a standard Ethernet cables (Cat 6 SFTP, 15 m length) with an effective data rate per pair of 640 Mbps. A cable driver DS15BA101 together with the equalizer DS15EA101 is used to ensure signal integrity between the transmitting CREAM and the receiving TELDES.

4.2 Peak recognition firmware

A peak at time t in the channel k is defined as a maximum energy deposit $\mathbf{E}_k(\mathbf{t})$ in space, time and larger than a programmable threshold:

$$\text{Peak in space :} \quad E_{k-1}(t) < \mathbf{E}_k(\mathbf{t}) > E_{k+1}(t) \quad (4.1)$$

$$\text{Peak in time:} \quad E_k(t-3) < E_k(t-2) < E_k(t-1) < \mathbf{E}_k(\mathbf{t}) > E_k(t+1) \quad (4.2)$$

$$\text{Peak over threshold:} \quad \mathbf{E}_k(\mathbf{t}) > E_{\text{threshold}} \quad (4.3)$$

where $E_{k-1}(t)$ and $E_{k+1}(t)$ are the energies at time t in the channels located above and below the channel “k” having the peak energy $E_k(t)$ (each channel is a blue square in figure 3). The expected

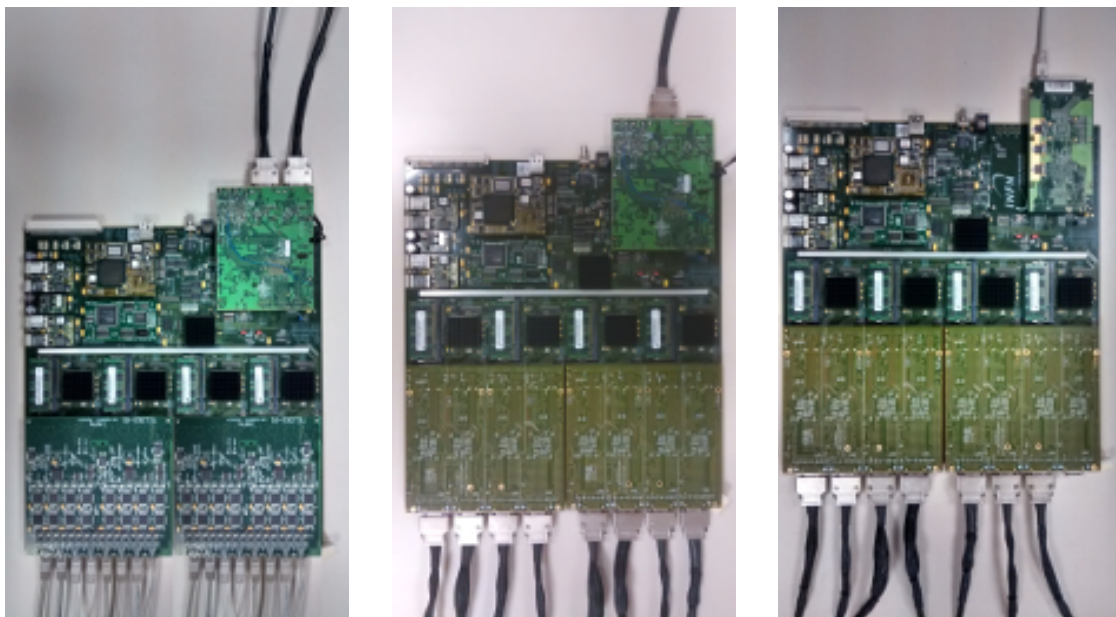

(a) One of the 28 front-end boards, each processing one vertical slice of the calorimeter. 32 TLS are received by two TELDES input mezzanines on serial links over standard Ethernet cables. The information on recognized peaks is redundantly sent, through the TX mezzanine, to two different concentrator boards.

(b) One of the 7 concentrator boards, each receiving data from 8 different front-end boards through two RX mezzanines: 4 calorimeter vertical slices are the region of interest for merging peaks into clusters along the horizontal directions, 2 slices left and 2 slices right are used to avoid multiple counting.

(c) 1 final concentrator board collects all data through two RX mezzanines and transmits trigger primitives to the Level 0 Trigger Processor over a Gbit Ethernet link.

Figure 4. The trigger is a 3-layer system. The TEL62 boards on each layer receive and transmit data through different I/O mezzanines as shown in pictures (a) to (c).

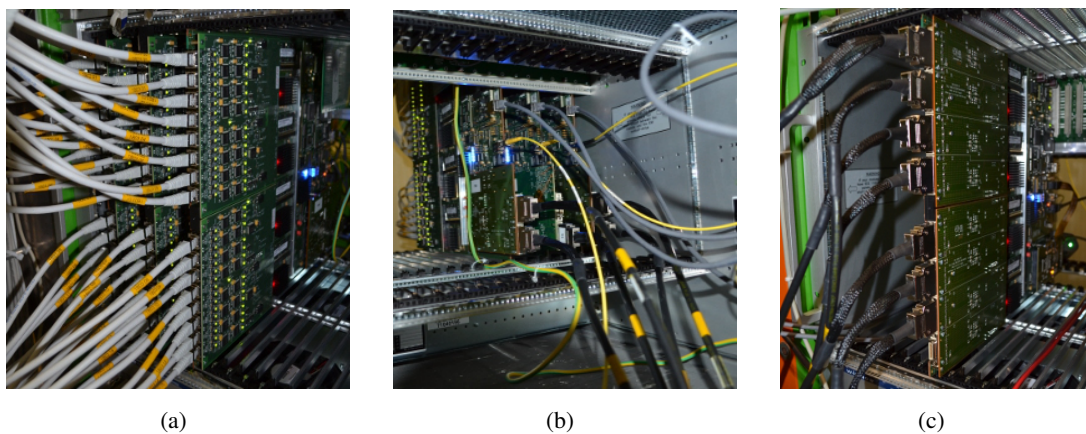

Figure 5. The system commissioned for the 2014 physics test run. Front-end boards are shown in (a) with the TELDES input boards in foreground (section 4.1) receiving serialized data from the CREAM. Elaborated trigger data is transferred with the internal serializer board (section 4.3) visible in (b). A concentrator board (c) merges this information received with the receiver boards (section 4.3).

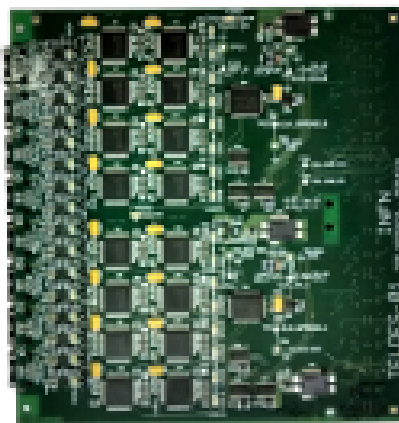

Figure 6. The TEL62 Deserializer Board (TELDES). Each Ethernet connector receives 2 calorimeter read-out channels. 16 equalizers and 16 deserializers chips are also visible.

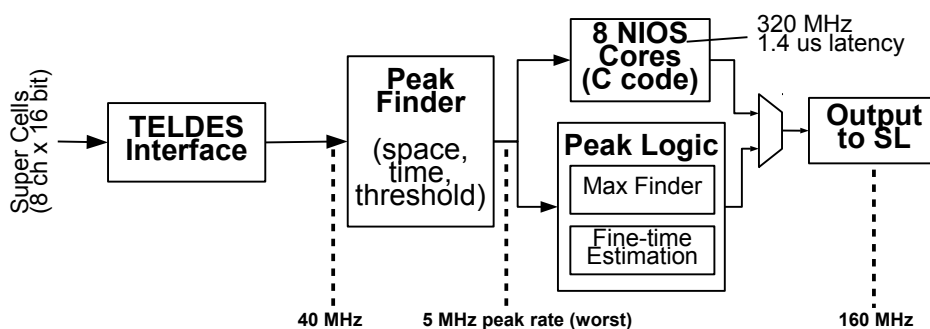

Figure 7. Scheme of the PP firmware: 8 16-bit data streams from the TELDES input mezzanine enter the system and a peak finder algorithm is applied as described by eq. (4.1)–(4.3). Data corresponding to a peak is then processed by a logic described in VHDL or by a software running on 8 NIOS cores. The peak maximum and its fine-time are calculated (see figure 8) and transferred to the rest of system for cluster merging and transmission to the Level 0 Trigger Processor.

maximum instantaneous hit rate on the calorimeter is 30 MHz and, considering the extension of each cluster and the topology of the trigger system, a safe (factor 3 worse) estimation of the maximum peak rate to be sustained by each front-end FPGA (processing 8 channels) is 5 MHz.

The firmware performing the peak recognition in the FPGAs of the front-end boards is sketched in figure 7. Each of the four Pre-Processing FPGAs of the front-end boards receives 8 16-bit input channels at 40 MHz (CREAM TLS, see also section 3 and 4) and looks for peaks in a pipelined and synchronized logic. On the data corresponding to peaks, a parabolic fit is performed to determine the peak maximum and to obtain a fine-time estimation of peak arrival (see later). This can be done with two alternative approaches. The first is a VHDL logic, synchronous with the 40 MHz inputs, with multipliers and dividers for the parabolic fit and recursive bisections between the samples for the fine-time estimation; being synchronous it is intrinsically immune to any change in the peak rate. The second, asynchronous, approach is a software, performing both the fit

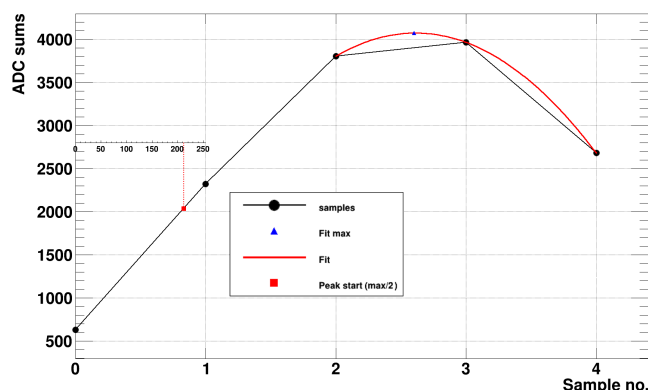

Figure 8. The plot shows the input and the output data of the Peak-Logic block of figure 7, that estimates the peak maximum and fine-time of the peak arrival time. A peak is identified over five 25 ns samples. A parabolic fit is performed around the maximum sample to find the true maximum (blue dot). The fine-time is an high-resolution timing of the peak arrival estimated with a *constant fraction discriminator* technique. If $\max(y_{\text{fit}})$ is the value of the peak maximum found by the parabolic fit, the fine-time is defined as the time t_0 such that $y(t_0) = \text{constant} \cdot \max(y_{\text{fit}})$. The hardware implementation assumes that the signal shape is linear around t_0 and performs an iterative bisection starting from the closest samples (reaching in 8 steps a resolution of $25 \text{ ns}/2^8 \approx 98 \text{ ps}$).

and the estimation of the peak fine-time, running on Altera NIOS II embedded processors clocked at 320 MHz; real-time measurements have shown that the maximum processing latency is $1.4 \mu\text{s}$, therefore 8 cores in a Round-Robin schedule are able to sustain the maximum estimated peak rate of 4.2 MHz.

4.2.1 Fine-time and energy resolution of the readout system

In order to obtain a preliminary determination of the resolution of the readout system, a signal shaped as a calibration pulse has been split and sent to two different CREAM inputs. The L0 trigger system has been used to simultaneously estimate the maximum and the fine-time of the ideally identical peaks on the two channels. The distribution of the differences between the fine-time values of the simultaneous peaks on the two channels is shown in figure 9(a) and has a standard deviation of 166 ps. The same kind of distribution for the difference in the peak maximum is shown in figure 9(b) and has a standard deviation of 0.6% the peak maximum. Both are obtained with the Peak Logic described in figure 8. Because of the systematic (worsening) effects of the measurement setup, they are both upper limits of the real resolutions. These values are lower than the calorimeter time resolution of 350 ps and 5% energy resolution for a photon with energy larger than 10 GeV.

4.3 The internal transmitter and receiver mezzanines

The communication between the three layers of the Level-0 trigger system is implemented with transmitter and receiver mezzanines based on the DS90CR485/6 SerDes chips.

The transmitter board, shown in figure 10(a), mounts an Altera Stratix II FPGA that receives and buffers data from the Sync-Link FPGA on board the TEL62, and transmits it on two links through two serializer DS90CR485. Each of them serializes 24 LVTTTL double edge inputs (48 bits

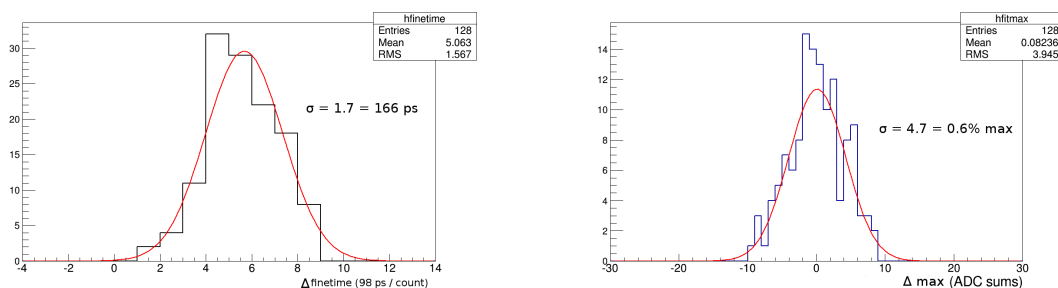

(a) Distribution of the difference between the reconstructed fine-time values of the peak onset of two channels receiving the same input.

(b) Distribution of the difference between the reconstructed maximum peak value (related to the peak energy deposit) of two channels receiving the same input.

Figure 9. Preliminary estimation of the fine-time and energy resolution of the system composed by the CREAM boards and the Level-0 trigger.

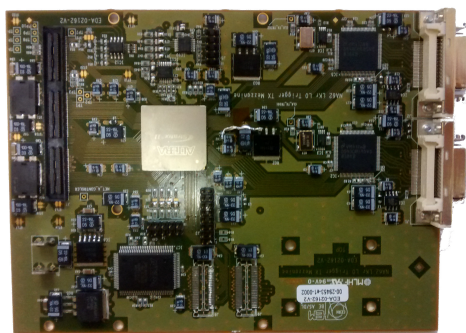

(a) The internal transmitter board with a Stratix II FPGA and two DS90CR485 serializer controlling two links. Each of the 28 front-end boards and of the 7^{1st} concentrator boards are equipped with this transmitter.

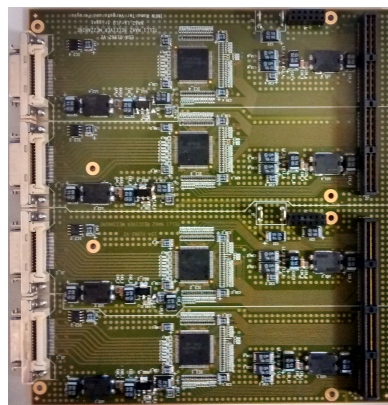

(b) The internal receiver board with four links controlled by DS90CR486 deserializers. Each of the 7^{1st} concentrator boards and the final concentrator are equipped with this receiver.

Figure 10. Transmitter (a) and receiver boards (b), used for data transmission between the front-end and the 1st concentrator layers and between the 1st and the 2nd concentrator layers of the Level-0 trigger.

data latched in per clock cycle) onto 8 LVDS streams. A phase-locked transmit clock is also in parallel with the data streams over a 9th LVDS link. For the test run the transmission clock is 70 MHz (3.360 Gbps per link).

The receiver board, shown in figure 10(b), manages four links with four DS90CR486 chips. Each Pre-Processing FPGAs will receive data from two links, each providing 48 bit data and the received clock. The physical link is a custom, halogen-free, 2 m cable with ten shielded twisted copper pairs and Mini D Ribbon type connectors.

4.3.1 Firmware interface and test results

The SerDes chipset is designed for operations with input clock between 66 and 133 MHz (up to 6.384 Gbps). Data-clock deskew is performed by the deserializer at power up or whenever controlled for this operation. Bit Error Rate (BER) Tests have shown that the quality of the deskew procedure is not constant and this can be critical at higher clock rates or with cables and connectors of lower quality. Therefore the firmware implements features² to check and control the result of the deskew procedure and to avoid uncontrolled transmission errors.

Extensive tests in the laboratory and at the experimental site have shown $BER < 10^{-15}$ (no error detected) in the 41-bit data payload and no single error corrected (or double error detected) by the Hamming decoder up to 85 MHz clock rate. This corresponds to 3.485 Gbps bandwidth for each link. At 100 MHz clock rate, corresponding to 4.1 Gbps per link, the result is still $BER < 10^{-15}$ with no errors in the 41-bit data payload but with single error corrected (no double error detected) by the Hamming decoder with a rate of about 10 errors per second. For the 2014 test run 70 MHz oscillators have been installed (2.870 Gbps per link) postponing the choice of the optimal link frequency for the 2015 physical run.

5 Discussion and conclusion

In this paper we have presented the design and the implementation of the Level-0 Trigger system of the Liquid Krypton Calorimeter of the NA62 experiment. In particular we discussed the tests performed during its commissioning for the 2014 physics test run of the experiment. Although a limited number of inputs is being used compared to the full system, all the hardware components are being tested.

In section 4.2 we have described the peak recognition firmware in the system Front-End layer and the processing limits of its architecture. The identification of the peaks and their processing (fit for maximum and fine-time estimation) can be completely pipelined with the input. Alternatively, the system can use NIOS II embedded processors that would not limit the processing capability as far as a sufficient number of them works in parallel; calculations show that 8 of them, easily fitting in the Stratix III being used, are enough to sustain the foreseen maximum instantaneous hit rate of 4.2 MHz per each front-end FPGA.³ The maximum system throughput is therefore dictated by the bandwidth of the transmission link between the different layers of the system. As described in section 4.3, the transmission link has an effective data transfer of 2.870 Gbps and can be reliably increased up to 3.485 Gbps without any transmission error being detected. Considering a data payload of 82 bits per peak, this translates in a limit of up to 10 MHz peak rate processed by each front-end FPGA (20 MHz per calorimeter vertical slice), that is higher than the worst case estimation of 4.2 MHz.

The 2014 test run will allow to test all components of the system and to be ready for the data taking at full luminosity for the 2015 run.

²Before normal operations each link is initialized with the transmitter sending a Pseudo Random Binary Sequence (PRBS, 23-bit generator) over the 48 bits of the link. The receiver repeatedly commands a deskew of the deserializer and checks the result (counting the errors in the received sequence) till a pre-defined link quality is achieved.

³In the actual implementation there is no functional difference between the VHDL logic and the NIOS software-based logic because the software is written to perform exactly the same task of the VHDL logic. The difference being in the added flexibility in implementing changes to the algorithm in software.

References

- [1] NA62 collaboration, *Proposal to Measure $K^+ \rightarrow \pi^+ \nu \bar{\nu}$ rare decay at the CERN SPS*, [CERN-SPSC-2005-013](#) (2005).
- [2] A.V. Artamonov et al., *New measurement of the $K^+ \rightarrow \pi^+ \nu \bar{\nu}$ branching ratio*, *Phys. Rev. Lett.* **101** (2008) 191802.
- [3] J. Brod et al., *Two-loop electroweak corrections for the $K^+ \rightarrow \pi^+ \nu \bar{\nu}$ decays*, *Phys. Rev. D*, **83** (2011) 034030.
- [4] NA62 collaboration, *NA62 technical design*, NA62-10-07 (2010).
- [5] M. Sozzi, *A concept for the NA62 trigger and data acquisition*, NA62-07-03 (2007).
- [6] NA48 collaboration, *The beam and detector for the NA48 neutral kaon CP violation experiment at CERN*, *Nucl. Instrum. Meth. A* **574** (2007) 433.
- [7] S. Venditti et al., *The NA62 liquid Krypton calorimeter's new readout system*, [2014 JINST 9 C01047](#).
- [8] E. Pedreschi et al., *Firmware approach for TEL62 trigger and data acquisition board*, in *Topical Workshop on Electronics for Particle Physics (TWEPP 2012)*, September 17–21, Oxford, U.K. (2012).
- [9] B. Angelucci et al., *The FPGA based trigger and data acquisition system for the CERN NA62 experiment*, [2014 JINST 9 C01055](#).
- [10] V. Bonaiuto et al., *Status of the NA62 liquid krypton electromagnetic calorimeter Level 0 trigger processor*, [2013 JINST 8 C02054](#).
- [11] A. Fucci et al., *The NA62 liquid krypton electromagnetic calorimeter level 0 trigger*, Proceedings of the 13th ICATPP Conference, 2011.
- [12] <http://www.altera.com>.