

THE BEAM CHOPPER POWER CONVERTER FOR MEDAUSTRON: SAFETY BY DESIGN AND DEVELOPMENT

T. Stadlbauer, R. Filippini, X. German, F. Osmic, P. Urschütz
EBG MedAustron, Wr. Neustadt, Austria

M.J. Barnes, T. Kramer, CERN, Geneva, Switzerland

M. Beerwald, U. Dirksen, Poynting GmbH, Dortmund, Germany

Abstract

MedAustron is the Austrian centre for hadron therapy and non-clinical research. The beam chopper system is an essential component for patient safety in specific hazardous situations as well as for beam delivery from the synchrotron to the irradiation rooms. This paper presents the results from the development phase and the commissioning of the MedAustron beam chopper system. Details will be given on the design, the risk management, the test and the verification of the chopper power converter (PKC).

SYSTEM DESCRIPTION

System Architecture

The beam chopper system is shown in Fig 1. It consists of one PKC, four kicker magnets (MKC [1], [2]) connected in series and a dump block, located in the high energy beam transfer line (HEBT).

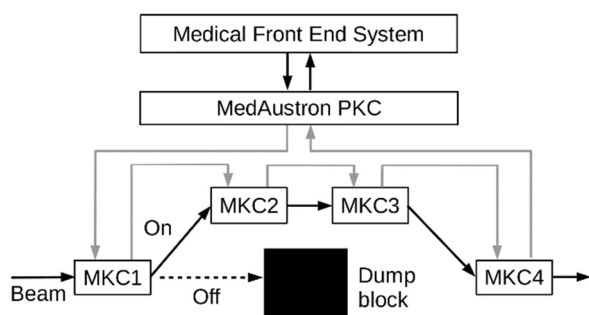

Figure 1: Schematic of the HEBT beam chopper system.

Functioning Principles

The beam chopper in the MedAustron Particle Therapy Accelerator (MAPTA) allows switching the beam in the irradiation room on and off. It performs two functions: 1) it contributes to deliver the beam into the irradiation rooms and 2) protects the patient from specific hazardous scenarios in case of faults. The system is designed to switch off the beam in less than 250 μs (Fig. 2), both in nominal and single fault condition. The beam chopper receives the set points, which are contained in the treatment file, from the accelerator control system (ACS) and is triggered by the Medical Front End (MF) system. If the chopper is switched on, the beam passes from the synchrotron through the chopper chicane in the HEBT to the irradiation room where the patient is treated. In case

of detected faults in MAPTA, the chopper is commanded to switch off the beam; the safe state for the patient.

	Nominal current	100 A – 630 A
	Magnet maximum B-field	136 mT
	Maximum output voltage (pulsed)	1500 V
	Voltage (DC)	60 V
	Repetition rate (max.)	20 Hz
	Rise and fall time (max.)	250 μs
	Dimension in mm	800 x 800 x 2000
	Weight	700 kg

Figure 2: System parameters of PKC SVM-630A manufactured by Poynting GmbH.

REALISATION AND DEVELOPMENT

Design Requirements Specification

The design requirement document was the reference for the beam chopper development, in addition to the quality targets, the test concepts, the applicable standards and the time plan. The specification of the design requirements was structured in order to facilitate the generation of test cases. The preliminary design report, including prototype test, was followed by the definitive design report which concluded the development phase at Poynting GmbH.

Risk Management

The risk assessment of the PKC was carried out according to the MedAustron risk management guidelines in agreement with the EN ISO 14971 standard [3]. The following points were addressed: 1) identification of hazards and categories at risk, 2) compliance with applicable safety standards and 3) risk assessment and evaluation. The hazards analysis identified the situations at risk for the patient during irradiation and for the personnel during service. The risk assessment and evaluation for the PKC was performed by a failure mode, effects and criticality analysis (FMECA) according to IEC 60812 [4]. The FMECA considered the design of the PKC in three stages. The first stage was the preliminary design where the conceptual design was examined; the second stage was the definitive design and the third stage the as-built design. The close collaboration of all involved

experts during the risk assessment process (electrical, software, mechanical, risk and project management) made it possible to obtain a feasible and robust design, for which all necessary risk reduction measures have been applied and validated. The ÖVE/ÖNORM E 8001-6-61 [5] was applied for testing the effectiveness of the mitigation measures against electrical hazards. In addition, provisions are implemented to be able to test the risk reduction measures. During maintenance the functionality of the risk reduction measures will be tested to detect possible failures which stay latent caused by the fault tolerant design.

SAFETY BY DESIGN

Patient Safety System

The PKC timing is controlled according to the treatment plan and by means of an online feedback system during normal treatment cycles, when faults are detected or when the beam has to be stopped. The function consists of switching off the magnet current in less than 250 μ s. Because of the relevant safety implications, this function needs to be very reliable and single fault safe. In order to achieve the objectives, it was decided to implement it exclusively in hardware, Fig. 3. For simple electrical/electronic components failure rates and failure modes are known [6]. These guideline values in addition to expert judgment were used to estimate the initial probability in the FMECA. This approach allowed overrating of particular electrical components or redundant component configurations to be valid risk reduction measures.

The PKC switch off safety chain starts with the trigger interface input section, which receives the trigger signals from the MF. From here, the signal reaches, two redundant branches, galvanically separated and autonomously powered. The two redundant power semiconductor switches sw1 and sw2 are cross triggered by the two independent branches, assuring a safe switch off even in the event of a non-functioning branch (single fault). Because of the particular logic implemented (on = beam passes through, off = the beam is off), the failure of a branch leads to the safe switch off of the PKC, and it is failsafe. This design approach has similarities with triggering distribution and synchronization system of the LHC beam dumping system [7], which commands the kicker magnets to extract the beam from the LHC, in a safe way.

The magnet current and properties of the chopper module, required for switching off the current in less than 250 μ s, are continuously supervised by the hardware based control system. Any detected violation of limits, for instance exceeding of current rise time or upper current limit, immediately results in switching off of the beam by means of the switch off section of the PKC.

The design of the switch off section of the PKC is done such that all other components, including software, can in no way switch on the beam. They can only inhibit the trigger and thus switch off the beam. This design feature

allowed reducing the scope of the FMECA of the PKC only to the parts which are relevant to perform the required switch off function.

The FMECA of the PKC has considered an operation time of 7500 hours per year (312 days) for 30 years, i.e. the lifetime in the risk management of MedAustron. The outcome resulted in more than 60 individual risks, which have been mitigated below the acceptable risk threshold. In order to reduce the risks, some 45 risk mitigation measures have been applied of which 20 are inherently safe (failsafe or robust design), 12 are preventive/protective safety chains, 7 are information for safety (service manual, maintenance, warning labels) and 6 are based on specific fault tolerant solutions. The most effective measures are the inherent safety measures, as these exclude that the hazardous situation can occur. The preventive/protective safety chains are the most demanding in terms of implementation as they must respond to a triggering event and complete the switch off safety action within a specified reaction time. Some safety chains can be reset. For these the PKC can resume operation as soon as the fault has been diagnosed and repaired. Fault tolerance has to be periodically inspected in order to avoid that dormant faults may accumulate. Information for safety is the least effective measure, and is used to increase awareness of personnel about hazardous situations during service.

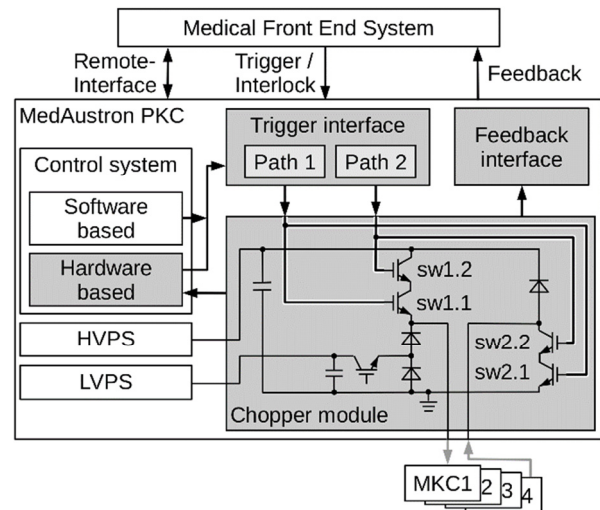

Figure 3: Components of MedAustron PKC (grey shaded components are exclusively implemented in hardware).

Personnel Safety System

The PKC operates at high currents and voltages and potentially represents a considerable danger for personnel. The certification of safety was done with respect to the ÖVE/ÖNORM E 8001, EN ISO 12100-1/2, EN ISO 14121-1, and the EN ISO 13849-1. The standards recommend the installation of specific safeguards, either passive (e.g. separation from live parts) or active such as switch-off mechanisms connected to protective enclosures or the interlocks from the Beam Interlock System during personnel access to the synchrotron. Emergency stop buttons are part of the active safeguards. A requested

current switch off is always realised in less than 250 μ s. In addition, labels and warning signs for specific dangers have been implemented and instructions for safety have been added in the service manual.

TEST, VERIFICATION AND COMMISSIONING

Safety Functions

The generated magnet current and the state of the MedAustron PKC are continuously supervised by the PKC control system. Examples of supervised parameters are the current rise time, current fall time, current overshoot, and lower and upper current thresholds at flat top. During current-off periods the redundant semiconductor switches sw1 and sw2 are tested for short-circuited state and the PKC output, including the cables and magnets, for isolation faults.

These safety functions are tested regularly at maintenance by means of integrated test functions or manual test procedures. The integrated test functions are hardware and software based. The preferred implementation of test functions was hardware based with the possibility of verification by measurements during the test. The test functions are always implemented by changing input parameters of the supervising functions resulting in the fault event. This allows the validation of the correct fault reaction and of the reported fault.

Performance

The performance of the PKC was validated in several stages: (a) at Poynting GmbH, before the delivery to MedAustron, with a test load and the ACS simulation box with predefined test cases, (b) at MedAustron within the site acceptance tests (SAT) and in the final configuration with magnets connected. The SAT was conducted firstly with the ACS simulation box and, afterwards, remotely fully integrated into the ACS. For the SAT verification, in addition to the two PKC internal LEM DCCTs, a setup close to the magnets included a DCCT (Fig. 4) and two Rogowski coils for the measurement of the edges and the flattop ripple, respectively.

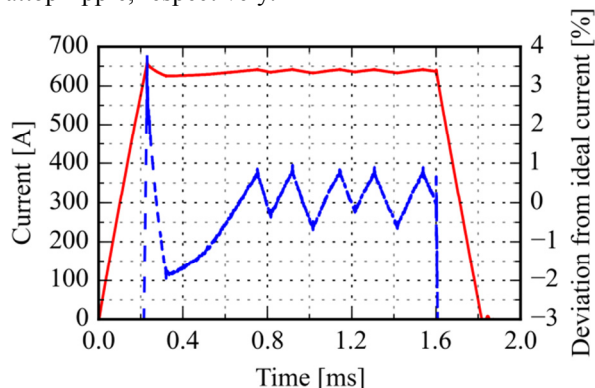

Figure 4: Measured current pulse (solid red: magnet current, dashed blue: deviation from ideal current).

The performance of the PKC fulfils the specified requirements and is compliant to all applicable European requirements (CE). The electromagnetic conformity of the PKC was assessed and confirmed by a notified and independent EMC competence centre [8].

CONCLUSION

In the MedAustron Particle Therapy Accelerator the PKC is an essential element for administering the treatment to the patient as well as for patient safety as it stops the beam in case of detected errors. This paper showed the design solutions that made it possible to reach a good balance between the two attributes, performance during treatment versus safety.

All applied technical solutions in the PKC have been designed in a “risk informed” way by implementing the recommendations that came out from the analysis of risks for the patient and the personnel. The evaluated residual risk for the patient stays largely within the acceptable limit (i.e. Risk Priority Number ≤ 10) and similar high safety levels have been reached with respect to the hazards concerning personnel. All identified safety functions of the PKC have been successfully tested and passed the safety inspection of the notified body.

The PKC has been designed, built, installed and commissioned in less than one year. In the development phase the collaboration among designers, risk analysts and manufacturers from MedAustron, CERN, and Poynting GmbH was a key factor for the successful completion of the project.

The PKC safety functions will be regularly tested according to the maintenance plan. By use of the extensive monitoring functions of the PKC the performance of the system will be constantly recorded and will be regularly analysed for quality assurance. The final verification step before patient treatment will be performed by the end of 2015 and will consist of functional tests of the safety chains of the patient protection system which control the PKC.

REFERENCES

- [1] J. Borburgh, et al., “Design and Development of Kickers and Septa for MedAustron”, proc. IPAC’10, Kyoto, Japan.
- [2] T. Kramer, et al., “Risk Assessment of the Chopper Dipole Kicker Magnets for the MedAustron Facility”, proc. IPAC’11, San Sebastian, Spain.
- [3] EN ISO 14971:2012
- [4] IEC 60812:2006
- [5] ÖVE/ÖNORM E 8001-6-61:2001
- [6] Reliability prediction of electronic equipment, MIL-HDBK-217
- [7] R. Filippini et al., “Reliability Analysis of the Trigger Synchronisation and Distribution System of the LHC Beam Dumping System”, CERN’13, Geneva, Switzerland.
- [8] EMC Test NRW GmbH, Germany