

COMPARISON OF BUNCH COMPRESSION SCHEMES FOR THE AXXS FEL

T. K. Charles, D. M. Paganin,

School of Physics and Astronomy, Monash University, Clayton, Australia

A. Aksoy, Ankara University, Golbasi / Ankara, Turkey

M. J. Boland, R. Dowd, Australian Synchrotron, Clayton, Australia

A. Latina, D. Schulte, CERN, Geneva, Switzerland

Abstract

Different types of electron bunch compression schemes are compared for the AXXS FEL design study. The main linac for the proposed machine is based on CLIC x-band structures. This choice leaves several options for the bunch compression schemes which impact the injection system RF band. Both harmonic linearization and phase modulation linearization are considered and their relative strengths and weaknesses compared. Simulations were performed to compare the performance of an s-band injector with a higher harmonic RF linearization to an entirely x-band injector and linearization scheme. One motivation for the study is to optimize the length of the AXXS machine, allowing the linac to fit onto the proposed site and also act as the injector to the existing storage ring at the Australian Synchrotron

AXXS

AXXS (Australian X-band X-ray Source) [1] is strategically planned to incorporate an upgrade of the current Australian Synchrotron storage ring and provide a new high brightness sub-Angstrom wavelength XFEL. The design includes a 6 GeV linac based around the CLIC x-band linac [2, 3].

PHASE MODULATION LINEARIZATION

In attempting to linearize the longitudinal phase space most FELs around the world employ harmonic linearization. When looking to design an all x-band linac, as is the case of AXXS, the high frequency accelerating structures preceding the first bunch compressor make harmonic linearization more difficult to achieve.

Phase modulation linearization is the term introduced in this paper to describe a new method of linearization. Through independently varying the phases of two cavities positioned before the first bunch compressor, 2nd order effects encountered through bunch compression can be minimized. These 2nd order effects refer to both the RF curvature impressed onto the beam during accelerating, plus the second order longitudinal dispersion, T_{566} , of the magnetic chicane.

Implementation of Phase Modulation Linearization is sketched in Fig. 1. To establish an energy chirp, the RF phase of the first section after the injector, ϕ_0 , is chosen to be 70°. The two additional cavities required for Phase Modulation Linearization are shown as having the parameters V_1, ϕ_1, V_2 and ϕ_2 .

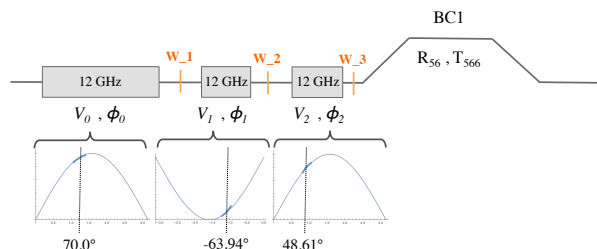

Figure 1: Layout of an x-band FEL accelerator design, up to end of first bunch compressor, which employs Phase Modulation Linearization. Included are markers showing location of longitudinal phase space plots in Fig. 3.

Analytical Approach

The beam energy after passing through the accelerating section leading up to the first bunch compressor is,

$$E_f = E_i + V_0 \cos(\phi_0 + k_x z_0) + V_1 \cos(\phi_1 + k_x z_0) + \dots + V_2 \cos(\phi_2 + k_x z_0), \quad (1)$$

where V_0, V_1, V_2 , represent the RF voltages of the three sections shown in Fig. 1, and ϕ_0, ϕ_1 , and ϕ_2 , are the RF phases of these sections, where the RF phase is defined to be 90° at the crest of the RF acceleration, and over the interval $0 < \phi < 90^\circ$ defines the negative slope of the RF curve (i.e. the head of the bunch is accelerated less than the tail). z_0 is the position of an electron with respect to the bunch center, and k_x is the wave number of the RF frequency.

The longitudinal position of any electron as it passes through the dispersive region of the chicane is,

$$z_f(\delta) = z_i + R_{56}\delta + T_{566}\delta^2 + U_{5666}\delta^3 + \dots \quad (2)$$

Taking the Taylor series expansion of Eq. 1, calculating the relative energy deviation and then substituting the result into to the dispersion relation (Eq. 2), the final longitudinal position is,

$$z_f = z_0 + R_{56}(az_0 + bz_0^2) + T_{566}(az_0 + bz_0^2)^2 + \text{higher order terms} \quad (3)$$

$$= z_0(1 + aR_{56}) + (bR_{56} + a^2T_{566})z_0^2 + 2abT_{566}z_0^3 + b^2T_{566}z_0^4 + \text{higher order terms} \quad (4)$$

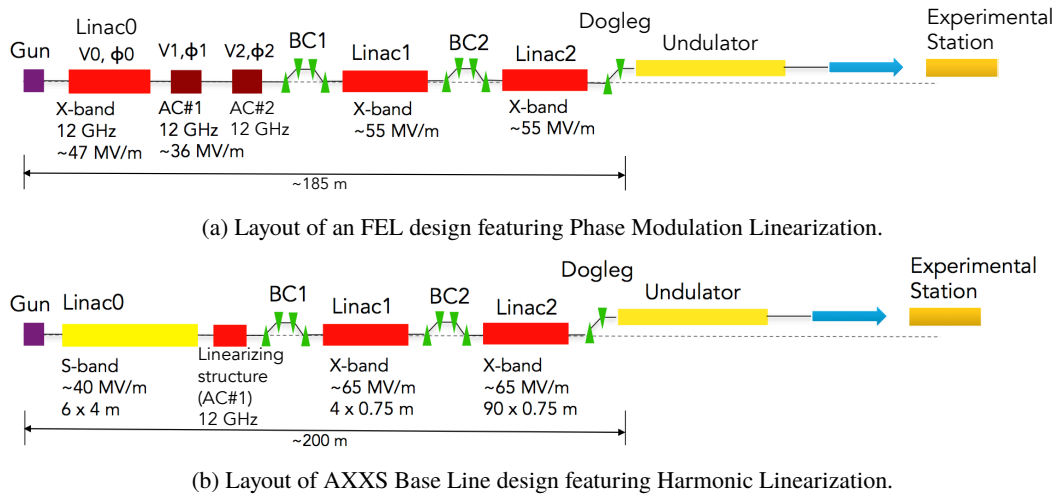

Figure 2: Two FEL design layouts each employing different techniques to linearize the longitudinal phase space.

where

$$a = \frac{k_x V_0 \cos \phi_0 + k_x V_1 \cos \phi_1 + k_x V_2 \cos \phi_2}{E_0} \quad (5)$$

and

$$b = \frac{-k_x^2 V_0 \sin \phi_0 - k_x^2 V_1 \sin \phi_1 - k_x^2 V_2 \sin \phi_2}{2E_0}. \quad (6)$$

To eliminate second order effects, the coefficient of the second order term of Eq. 4, can be made to equal zero, ($bR_{56} + a^2T_{566} = 0$). As there are multiple solutions to this equation, the chosen solution was based on the criteria of minimizing not only the coefficient of the second order term, but also to minimize of the coefficient of the first order term (of Eq. 4), and to ensure minimal deceleration of the beam was required.

A side effect of this linearization technique is that the beam is necessarily decelerated to a degree, but perhaps surprisingly the magnitude of deceleration is not large, at 6.73%, for the scenario simulated in the next section. If only one additional cavity of differing phase was included before the bunch compressor, a large degree of deceleration would be necessary in order to cancel out the 2nd order effects, making it an impracticable solution. It is with the addition of the second additional cavity (again of different phase) which allows the second order effects to be minimized without the need to decelerate the beam significantly.

Elegant Simulation

A 6D simulation of the Phase Modulation Linearization method was created using Elegant [4]. Inclusion of collective effects such as coherent synchrotron radiation, have not yet been included into this simulation. Longitudinal wakefields have been included based upon calculations using the CLIC x-band accelerating structures.

The longitudinal phase space of the electron beam at three positions before the first bunch compressor, is shown in

Table 1: Parameters Used in Simulations (where AC#1 and AC#2 stand for Additional Cavity number 1 and 2).

Parameter		Phase Mod. Lin.	Harmonic Lin.
Linac0 RF voltage (MV)	V_0	46.65	15.97
Linac0 RF phase	ϕ_0	70°	70°
Linac0 RF freq. (GHz)	f_{RF}	12	3
AC#1 RF voltage (MV)	V_1	46.50	46.65
AC#1 RF phase	ϕ_1	-63.94°	-61.5°
AC#1 RF freq. (GHz)	f_{RF}	12	12
AC#2 RF voltage (MV)	V_2	26.70	-
AC#2 RF phase	ϕ_2	48.61°	-
AC#2 RF freq. (GHz)	f_{RF}	12	-
BC1 long. disp. (mm)	R_{56}	-10.91	-13.02
BC1 2 nd order disp. (mm)	T_{566}	16.37	19.53
BC2 long. disp. (mm)	R_{56}	-5.21	-4.22
BC2 2 nd order disp. (mm)	T_{566}	7.82	6.34

Fig. 3, where the distribution labeled W_3 appears just before the bunch compressor. This series of plots shows the linearization of RF induced curvature.

Figure 4, shows the longitudinal phase space at the beginning and end of BC1 and again at the beginning and end of BC2. After two stage bunch compression, a final compression ratio of 132.36 is achieved. At the end of the linac, a final bunch length of 19.86 fs is achieved with a peak current of 33.78 kA (Fig. 5).

COMPARISON WITH HARMONIC LINEARIZATION

In this section we compare Phase Modulation Linearization with the most commonly used other method of linearization, Harmonic Linearization [6]. These simulation results use parameters from the base line FEL design produced by

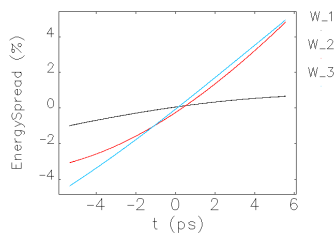
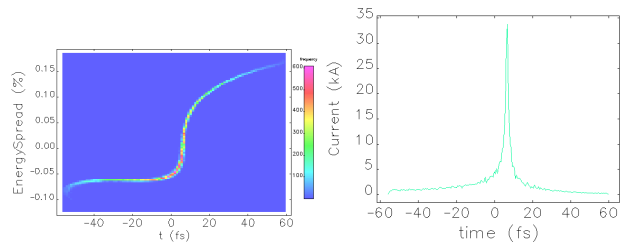
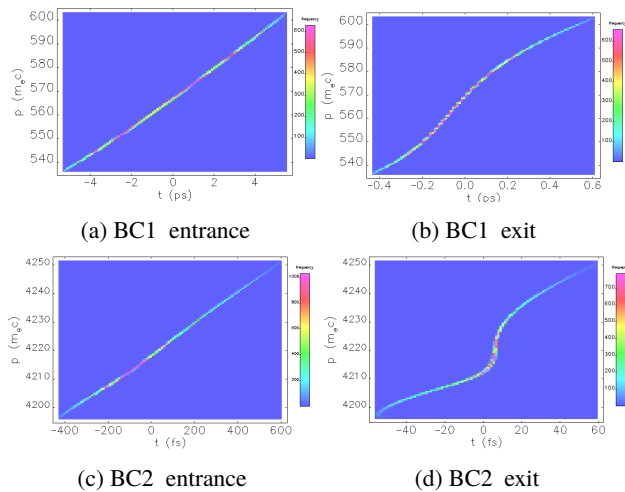

Figure 3: Longitudinal phase space at 3 positions before the bunch compressor, showing linearization of the curvature introduced by the RF curvative. Location where each phase space plot was generated is shown in Fig. 1.



(a) Longitudinal phase space (b) Current profile

Figure 5: Beam properties at the end of Linac2, utilizing Phase Modulation Linearization.



(a) BC1 entrance (b) BC1 exit
(c) BC2 entrance (d) BC2 exit

Figure 4: Longitudinal phase space evolution through two bunch compressors using Phase Modulation Linearization.

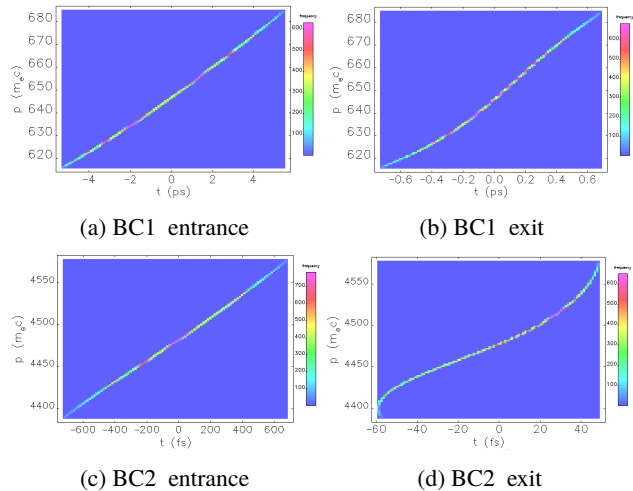

(a) BC1 entrance (b) BC1 exit
(c) BC2 entrance (d) BC2 exit

Figure 6: Longitudinal phase space evolution, through the two bunch compressors using Harmonic Linearization.

the XbFEL collaboration [3]. Beginning with an S-band injector, this design uses harmonic linearization through the inclusion of a 12 GHz structure positioned just before the first bunch compressor. The layout of this design is shown in Fig. 2b.

Elegant simulation results in Fig. 6 show the longitudinal phase space at the beginning and end of BC1 and at the beginning and end of BC2. After two-stage bunch compression, a final compression ratio of 83.25 is achieved. At the end of the linac, a final bunch length of 31.74 fs is achieved with a peak current of 2.95 kA (Fig. 7). Both simulations of Phase Modulation Linearization and Harmonic Linearization require more work to minimize the energy spread at the end of the linac. However the simulations do show how the longitudinal phase space can be effectively linearized.

CONCLUSION

We have shown through simulation, and a brief analytical derivation, the effectiveness of Phase Modulation Linearization. Using this method to eliminate 2nd order effects of bunch compression, the electron bunch can be compressed to a final bunch length of 19.86 fs and a peak current of 33.78 kA. A comparison was made between Phase Modulation Linearization and the widely used Harmonic Linearization

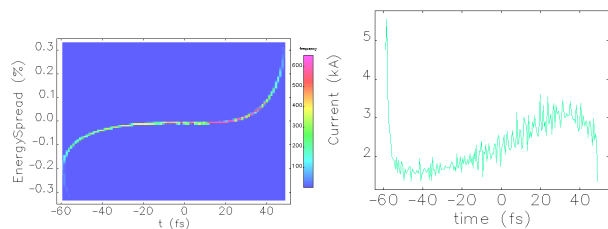

(a) Longitudinal phase space (b) Current profile

Figure 7: Beam properties at the end of Linac2, utilizing Harmonic Linearization.

method. Finally, Phase Modulation Linearization could open up the possibility to tailor the beam current profile through altering the voltage and phase of the additional cavities.

REFERENCES

- [1] M. Boland *et al.*, "Plans for an Australian XFEL Using a CLIC x-band Linac", in *Proc. IPAC'14*, Dresden, Germany, Jun. 2014, paper THPME081, p. 3424.
- [2] A. Grudiev, D. Schulte, "The Accelerating Structure for A 500 GeV CLIC", in *Proc. LINAC'10*, Tsukuba, Japan, Aug. 2010.
- [3] A. Aksoy *et al.*, "Conceptual design of a X-FEL facility using CLIC x-band accelerating structure", in *Proc. IPAC'14*, Dresden, Germany, Jun. 2014, paper THPRO025, p. 2914.

- [4] M. Borland, “Elegant: A Flexible SDDS-Compliant Code for Accelerator Simulation”, Advanced Photon Source, ANL, Argonne, IL, USA, Rep. LS-287, Sep. 2000.
- [5] A. Aksoy *et al.*, “FEL Proposal Based on CLIC X-Band Structure”, in *Proc. FEL'14*, Basel, Switzerland, Aug. 2014, paper MOP062, p. 186.
- [6] P. Emma, “X-Band RF Harmonic Compensation for Linear Bunch Compression in the LCLS”, SLAC, Stanford, CA, USA, Rep. ILCLS-TN-01-1, Nov. 2001.