

# DESIGN AND PROTOTYPING OF HL-LHC DOUBLE QUARTER WAVE CRAB CAVITIES FOR SPS TEST\*

S. Verdú-Andrés<sup>#</sup>, J. Skaritka, Q. Wu, B. P. Xiao, BNL, Upton, NY 11973, USA

S. Belomestnykh, I. Ben-Zvi, BNL, Upton, NY 11973, USA; SBU, Stony Brook, NY 11790 USA  
L. Alberty, K. Artoos, R. Calaga, O. Capatina, T. Capelli, F. Carra, R. Leuxe, N. Kuder, C. Zanoni,  
CERN, Geneva, Switzerland

Z. Li, SLAC, Menlo Park, CA 94025, USA, A. Ratti, LBNL, Berkeley, CA 94707, USA

## Abstract

The LHC high luminosity project envisages the use of the crabbing technique for increasing and levelling the LHC luminosity. Double Quarter Wave (DQW) resonators are compact cavities especially designed to meet the technical and performance requirements for LHC beam crabbing. Two DQW crab cavities are under fabrication and will be tested with beam in the Super Proton Synchrotron (SPS) at CERN by 2017. This paper describes the design and prototyping of the DQW crab cavities for the SPS test.

## INTRODUCTION

The LHC luminosity upgrade would significantly increase the potential to discover new physics from rare events. Bunch crabbing is one of the proposed techniques for increasing and levelling the LHC luminosity [1].

The first phase of the crab cavity program was to validate the design by demonstrating the nominal deflecting voltage. The first prototype of a DQW crab cavity was successfully cold tested at BNL in 2014 [2].

The next phase of the program envisages testing of the crab cavities with proton beams in SPS by 2017. A prototype cryomodule will host two fully dressed DQW crab cavities. The tests will try to crab bunches of proton beams for the first time ever.

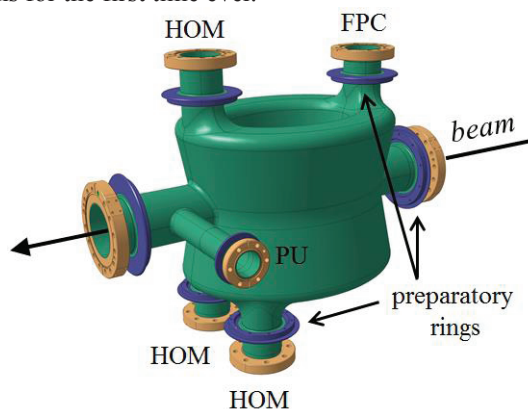

Figure 1: Bare SPS DQWCC with flanges and rings.

\*Work supported by US DOE through Brookhaven Science Associates LLC under contract No. DE-AC02-98CH10886 and the US LHC Accelerator Research Program (LARP) and by EU FP7 HiLumi LHC – Grant Agreement 284404. This research used resources of the National Energy Research Scientific Computing Center, which is supported by US DOE under contract No. DE-AC02-05CH11231.

<sup>#</sup>sverdu@bnl.gov

## DQW CRAB CAVITY FOR SPS TESTS

Optimization of the cavity body and port tubes was discussed in previous papers [3,4] and focused on reducing residual accelerating voltage and peak surface fields while respecting clearance requirements for the adjacent LHC beam pipe.

Position of the flanges has been carefully chosen to reduce the dissipative losses in the copper RF-seal gaskets while respecting space constraints of the cryomodule.

Figure 1 shows a bare DQW crab cavity with flanges and preparatory rings. Table 1 summarizes the main geometric and electromagnetic properties of the SPS DQW crab cavities.

Table 1: Properties of SPS DQWCC

Geometrical parameter (at 300K)	Unit
Cavity length $L$	352 mm
Cavity width $W$	288 mm
Cavity height $H$ (w/o ports)	286 mm
Beam pipe diameter	84 mm
Port diameter	62 mm
Electromagnetic quantity (Microwave Studio [5] simulations)	Unit
Crab mode frequency $f_0$	400 MHz
Nearest mode frequency $f_1$	570 MHz
Deflecting voltage $V_t^{(1)}$	3.34 MV
Deflecting gradient $V_t/L_{\text{cavity}}^{(2)}$	9.5 MV/m
Accelerating voltage $V_{\text{acc}}^{(2)}$	15 kV
Electric field center offset	0.23 mm
Peak surface electric field $E_{pk}^{(2)}$	37 MV/m
Peak surface magnetic field $B_{pk}^{(2)}$	72 mT
Stored energy $U^{(2)}$	10 J
$R_t/Q$	429 $\Omega$
Geometric factor $G$	87 $\Omega$

(1) Nominal deflecting voltage per cavity [6].

(2) For a nominal deflecting voltage  $V_t$  of 3.34 MV.

### Couplers

Ports for the Fundamental Power Coupler (FPC) and Higher Order Mode (HOM) couplers are located in the inductive region of the cavity to ease cavity interior surface cleaning. To provide an efficient coupling to the magnetic field region, hook-type coupling elements are used for both FPC and HOM filters. All couplers are detachable from the cavity to facilitate cleaning and installation. The HOM filter is discussed in a separate paper [7].

The FPC is made of copper. The external Q for the FPC is  $5.3 \times 10^5$ . The input RF power required to reach a nominal deflecting voltage of 3.34 MV is 12 kW. The FPC hook has an elliptical cross section to improve thermal conduction. Dissipated power and maximum peak magnetic field on the hook surface are 100 W and 8 mT, respectively, for the nominal deflecting voltage. The FPC has a water-cooling channel along the stem that ends at the beginning of the hook blending. ANSYS [8] simulations show a maximum temperature of 393K found on the tip of the hook for the nominal deflecting voltage. The FPC hook has been optimized to reduce sensitivity to mechanical tolerances and ease insertion of the coupler into port tube (5 mm clearance with respect to port wall). The main dimensions of the FPC hook are shown in Figure 2.

The RF Pick-Up (PU) port is attached to one of the beam pipes. The PU coupler is made of copper. It has an external Q of  $1.6 \times 10^{10}$ , which allows extracting about 1 W of the fundamental mode power.

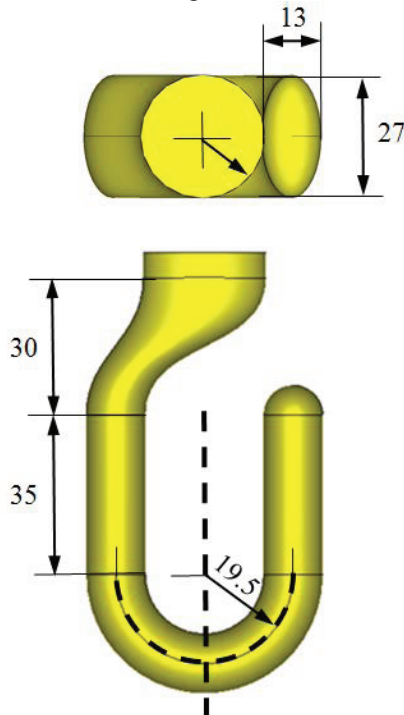

Figure 2: FPC hook for SPS DQWCC.

### Multipacting

Multipacting within the cavity body is predicted by ACE3P [9] at low voltages. The same multipacting band was found for the PoP DQW but was processed through quickly. Weak signatures of possible multipacting are also predicted at the blending of the ports. The multipacting found in the FPC port will require high-power conditioning.

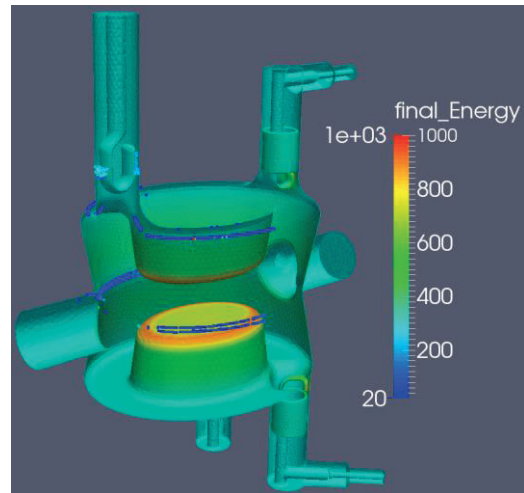

Figure 3: Multipacting sites in SPS DQWCC.

### HELIUM VESSEL AND TUNER

The helium vessel is made of titanium. NbTi rings are used to connect cavity and helium vessel. These rigid connections provide additional stiffening to the inductive region of the cavity. The adjacent beam pipe is integrated into the helium vessel.

The tuning system provides additional stiffening to the capacitive plates of the cavity during cooldown and pressure changes. The tuning system is connected to the central part of the cavity plates and to the external major radius of the plates by NbTi interfaces. The scissor system shown in Figure 5 is adopted for symmetric actuation onto both plates, though a slightly different force is applied to the upper and lower plates due to the asymmetric distribution of cavity ports.

### Frequency Shifts

The finite element solver ANSYS-APDL 14.5 was used to evaluate the frequency shifts for cooldown, pressure variations and cavity operation. The frequency shift for cooldown from 300 K to 2 K is -573 kHz. The pressure sensitivity is about 0.1 Hz/mbar. Expected Lorentz force detuning for nominal deflecting voltage is negligible ( $< 1$  Hz) due to stiffening provided by the helium vessel and tuner in both capacitive and inductive regions.

### Tuning Strategy

The cavity will be pre-tuned by plastic deformation of the capacitive plates. The relative distance between helium vessel top-plate and tuning system can be adjusted

to provide this deformation. This coarse tuning has a sensitivity of 1.6 MHz/mm.

Tuning during operation will be provided by a push-pull system. This fine tuning has a sensitivity of 372 kHz/mm and it is limited to 0.5 mm by the stepper motor. The tuning system also incorporates a piezo for fast tuning.

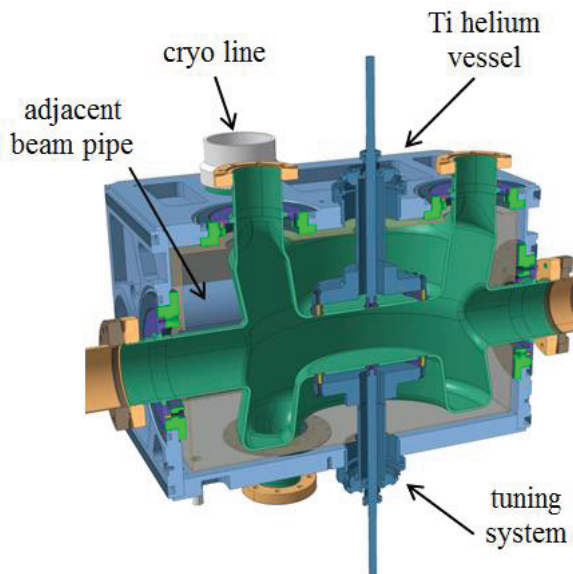

Figure 4: SPS DQWCC into helium vessel with tuner.

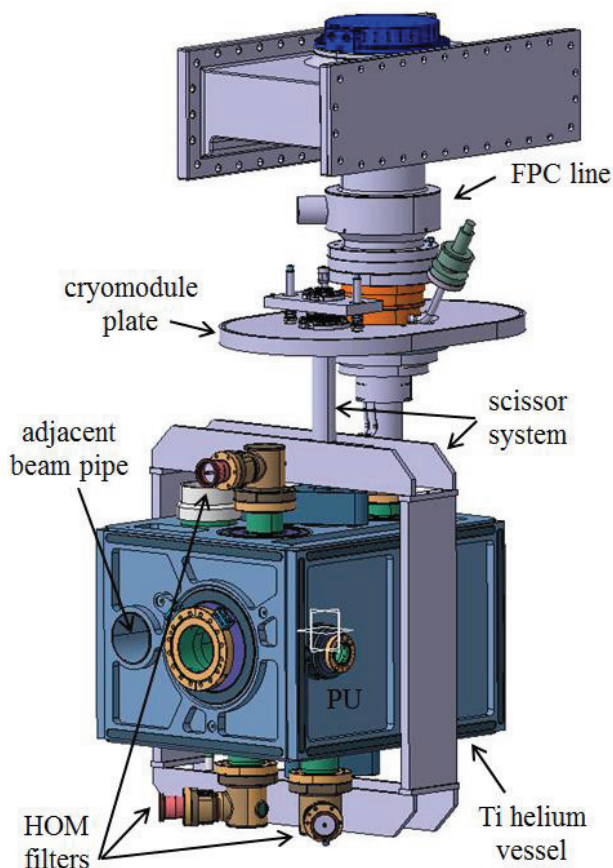

Figure 5: Full view of helium vessel and tuning system.

## DQW CRAB CAVITY PROTOTYPES

Cavity parts will be formed by Niowave Inc. from 4 mm Nb sheets for the main cavity body and 3 mm Nb sheets for the ports. Requested Nb sheets must be fine grain with RRR > 300. All the flanges will be made of SS316LN and will be brazed to the cavity port subassemblies. Then parts will be put together by Electron Beam Welding (EBW).

The most sensitive parameters to machining tolerances are the cavity height and waist, for which the frequency changes about 0.5% and 0.3%, respectively, for a 1 mm fabrication error.

The geometry provided for fabrication is dimensioned to account for shrinkage due to cooldown and for the inner volume increase as result of a series of bulk Buffer Chemical Polishing (BCP) of 150  $\mu\text{m}$  thickness removal and two light BCPs of 30  $\mu\text{m}$  thickness removal each prior to cavity installation in SPS. The expected frequency shift due to a total 210  $\mu\text{m}$  of BCP is 0.17 MHz according to ANSYS-APDL simulations.

## STATUS AND FUTURE PLANS

Two DQWCC prototypes for beam tests at SPS are currently under fabrication.

The cavity prototypes will undergo surface treatment, baking, and then vertical cryogenic tests will be conducted at BNL in 2016. Afterwards the cavities will be assembled into their helium vessels and pre-tuned.

The cavities will be then sent to CERN for assembly into the cryomodule and installation in SPS for the beam tests of 2016-2017.

## REFERENCES

- [1] R. Calaga and E. Jensen, "LHC Crab Cavity Progress and Outlook", SRF'2013, Paris, France (2013).
- [2] B. P. Xiao et al., "Design, Prototyping and Testing of a Compact Superconducting Double Quarter Wave Crab Cavity", Phys. Rev. ST Accel. Beams 18, 041004 (2015).
- [3] R. Calaga et al., "A Double Quarter Wave Deflecting Cavity for the LHC", WEPWO047, IPAC'13, Shanghai, China (2013).
- [4] S. Verdú-Andrés et al., "Optimization of the Double Quarter Wave Crab Cavity Prototype for Testing at SPS", THP041, SRF'2013, Paris, France (2013).
- [5] CST Microwave Studio Suite 2014.
- [6] P. Baudreghien et al., "Functional Specifications of the LHC Prototype Crab Cavity", CERN-Acc-Note-2013-003 (April 2013).
- [7] B. P. Xiao et al., "Higher Order Mode Filter Design for Double Quarter Wave Crab Cavity for the LHC High Luminosity Upgrade", these proceedings.
- [8] ANSYS v. 14.5.
- [9] ACE3P code: Omega3P and Track3P.