

HiLumi LHC

FP7 High Luminosity Large Hadron Collider Design Study

Deliverable Report

Design Study of the Cooling

Bozza, G (CERN) *et al*

12 October 2015



The HiLumi LHC Design Study is included in the High Luminosity LHC project and is partly funded by the European Commission within the Framework Programme 7 Capacities Specific Programme, Grant Agreement 284404.

This work is part of HiLumi LHC Work Package 3: **Magnets for Insertion Regions**.

The electronic version of this HiLumi LHC Publication is available via the HiLumi LHC web site <<http://hilumilhc.web.cern.ch>> or on the CERN Document Server at the following URL:
<<http://cds.cern.ch/search?p=CERN-ACC-2015-0125>>

Grant Agreement No: 284404

HILUMI LHC

FP7 High Luminosity Large Hadron Collider Design Study
Seventh Framework Programme, Capacities Specific Programme, Research Infrastructures,
Collaborative Project, Design Study

DELIVERABLE REPORT

DESIGN STUDY OF THE COOLING

DELIVERABLE: D3.4

Document identifier:	HILUMILHC-Del-D3-4-v1.0
Due date of deliverable:	End of Month 48 (October 2015)
Report release date:	12/10/2015
Work package:	WP3 IR Magnets
Lead beneficiary:	CERN
Document status:	Final

Abstract:

This report summarizes the design choices for the inner triplets' baseline cooling option by means of superfluid helium, the main requirements which the magnets and their cryostat piping have to adhere to as well as the expected cooling performance. The cooling performance is evaluated in terms of temperature margin of the magnets under full steady state heat load conditions and in terms of local maximum-sustainable load. The cooling method is based on transfer of the proven superfluid helium cooling method, as used in the present LHC, to the HiLumi inner triplet magnets. The focus of the report is primarily on the cryogenic requirements to be imposed on the magnet cold masses and the evaluation of resultant temperature margins.



Copyright notice:

Copyright © HiLumi LHC Consortium, 2015.

For more information on HiLumi LHC, its partners and contributors please see www.cern.ch/HiLumiLHC

The HiLumi LHC Design Study is included in the High Luminosity LHC project and is partly funded by the European Commission within the Framework Programme 7 Capacities Specific Programme, Grant Agreement 284404. HiLumi LHC began in November 2011 and will run for 4 years.

The information herein only reflects the views of its authors and not those of the European Commission and no warranty expressed or implied is made with regard to such information or its use.

Delivery Slip

	Name	Partner	Date
Authored by	R. van Weelderen, G. Bozza	CERN	23/09/2015
Edited by	R. van Weelderen, C. Noels	CERN	08/10/2015
Reviewed by	S. Claudet, WP9 Coordinator E. Todesco, WP3 Coordinator L. Tavian, Cryogenics Group leader L. Rossi, Project Coordinator	CERN CERN CERN CERN	29/09/2015
Approved by	Steering Committee		08/10/2015

TABLE OF CONTENTS

1. INTRODUCTION 5

2. DESCRIPTION OF THE INNER TRIPLET MAGNETS 6

3. COOLING REQUIREMENTS FOR CRYOSTATS LAYOUT AND MAGNET COLD MASSES..... 6

3.1. COOLING BY SUPERFLUID HELIUM: MAIN – LONGITUDINAL – HEAT EXTRACTION6

3.2. COOLING BY SUPERFLUID HELIUM: RADIAL EXTRACTION10

 3.2.1. *MQXF-quadrupoles*10

 3.2.2. *D1-dipole*10

3.3. SUMMARY OF MAIN COLD MASS REQUIREMENTS11

4. THERMAL PERFORMANCE EVALUATION 11

4.1. THERMAL MODEL AND INPUT CONDITIONS11

4.2. STEADY STATE TEMPERATURE DISTRIBUTION, TEMPERATURE MARGIN AND LOCAL MAXIMUM-SUSTAINABLE LOAD15

 4.2.1. *MQXF-quadrupole*.....15

 4.2.2. *D1 dipole*.....18

4.3. MAXIMUM TRANSIENT POWER EXTRACTION LIMITS OF THE MQXF DESIGN (MQE/TAU).....20

5. CONCLUSIONS..... 21

6. REFERENCES 22

Executive summary

The general cooling layout and infrastructure needed to extract more than one kW of power at 1.9 K from the 58 m long string of magnets (Q1 up to D1) is similar to proven LHC configurations. The 1.9 K specific sizing requirements are shown to be feasible within the available cold mass space as long as the two-phase cooling loops are composed of two parallel bayonet heat exchangers and separated into three independent units, which together cover the full magnet string.

The requirements imposed on the cold mass design to enable cooling the inner triplets by superfluid helium have been integrated in the magnet design since the early stage of the design study. The design details enabling to radially conduct the power deposit due to debris from the interaction points from the coils towards the cold source have been gradually refined, and the combined effect on magnet performance is evaluated in terms of temperature margin of the magnets under full steady state heat load conditions and in terms of local maximum sustainable load; i.e. minimum quench energy (MQE). The resultant temperature margins as modelled for the MQXF – quadrupoles (4.1 K) and for the D1 – dipole (2.4 K) are within the acceptable range for safe operation. Improvement can be inferred from the temperature margin maps if the most critical zones so identified could be better shielded

With the steady state cooling layout defined and the magnet performance quantified as fully acceptable one has now to address the thermo hydraulics due to transients. The exploration of the transition in MQE values from well cooled to partially-cooled and finally adiabatic would necessitate a refinement of the global cooling model developed so far. A safety analysis of pressure development after magnet quench or catastrophic insulation vacuum break down is necessary to define the safety strategy and quantify the safety devices.

1. INTRODUCTION

The final focusing magnets for the High Luminosity upgrade of the LHC (HL-LHC [1]) will receive a heat load due to debris coming from the adjacent particle interaction points: the computed peak heat deposition in the coil is of the order 4 mW/cm^3 ([2], [3]). Superconducting magnets based on Nb_3Sn cable technology and operating in superfluid helium at temperatures below 2 K are the objective of current magnet R&D and constitute the baseline for the project [4]. They are of a new type and the integrated heat load they have to handle is higher than accustomed.

The cooling method is based on a transfer of the proven superfluid helium cooling method, as used in the present LHC, to the HiLumi inner triplet magnets. The overall cryogenic infrastructure needed is similar, but scalable from the existing configuration. A backup cooling method using supercritical helium, but at higher temperatures and thus lower magnetic field gradient, is reported in [5].

This report builds upon the intermediate milestone report on superfluid helium cooling [6]. It summarizes the design choices for the inner triplets' baseline cooling option by means of superfluid helium, the main requirements which the magnets and their cryostat piping have to adhere to as well as the expected cooling performance. The cooling performance is evaluated in terms of temperature margin of the magnets under full steady state heat load conditions and in terms of local maximum sustainable load; i.e. minimum quench energy (MQE).

2. DESCRIPTION OF THE INNER TRIPLET MAGNETS

The magnets have one beam pipe protruding over the full length through which the accelerated particles travel. Separated from it by an annular gap, filled with He, are the superconducting coils, usually two layers, embedded in an iron structure to maintain all the forces and to guide and shape the magnetic field. This whole, so-called cold-mass, is enclosed in a vessel, to be kept at the chosen operating temperature and supported in a vacuum insulated cryostat. In the following we will discuss the cooling channels and their configuration specific to the cold masses only.

The Inner Triplet magnets are installed on both sides of the interaction points IP1 and IP5. They comprise of four ensembles of six cryostats housing the following magnets: four inner triplet quadrupoles (Q1, Q2a, Q2b, and Q3), one corrector package (CP) and one dipole (D1). The quadrupoles will be made using Nb₃Sn coils whereas the CP and D1 will use Nb-Ti coils. The cryostats are about 4 m to 7 m in length each, with up to 3 m of cold interconnects. One ensemble forms a continuous cryostat with a total length of 58 m.

The heat loads due to debris from the adjacent particle interaction point are intercepted at two distinct magnet locations and temperature levels. A first heat intercept is on tungsten absorbers which are placed inside the beam pipe vacuum and which will be cooled in the 40 K to 60 K range. This heat intercept is outside of the scope of this report. The remaining heat load will fall on the cold mass volume comprised of the yoke, collars and coils, referred to as “cold masses” for the remainder of this article. The heat loads for only one set of 6 magnets are used for calculation. For the purpose of the evaluation of the cooling, the heat load to the cold masses is taken at 1050 W. It includes an estimated static load of 100 W, arriving mainly at the cold-mass periphery, and 950 W from particle debris distributed over the full magnet section. All values are based on an ultimate luminosity of $7.5 \times 10^{34} \text{ cm}^{-2} \text{ s}^{-1}$ ([2], [3]).

3. COOLING REQUIREMENTS FOR CRYOSTATS LAYOUT AND MAGNET COLD MASSES

3.1. COOLING BY SUPERFLUID HELIUM: MAIN – LONGITUDINAL – HEAT EXTRACTION

The cooling principle as depicted in Figure 1 is an evolution of the one proposed for the LHC-Phase-I Upgrade [7]. The cold masses will be cooled in a pressurized static superfluid helium bath at 1.3 bar and at a temperature of about 1.9 K. The heat generated in the magnets will be extracted by vaporization of superfluid helium which travels as a low pressure two-phase flow in two parallel bayonet heat exchangers (HX) [8], protruding the magnet yokes (depicted as one bold line in Figure 1). The low vapour pressure inside the heat exchanger is maintained by a cold compressor system, with a suction pressure of 15 mbar, corresponding to the saturation temperature of 1.776 K.

The flow diagrams for the four site implementations (Left of IP1, Right of IP1, Left of IP5, and Right of IP5), are very similar. They differ in orientation left-right, so Q1 will always face the IP, and have slope dependence for the HeII two-phase flow in the HX, so the flow is always down-stream. Figure 2, courtesy D. A. Berkowitz, shows the flow diagram version applicable to the right side of IP5. On top are depicted the supply headers for cryogenes, with

two jumper connections between it and the magnet cryostats. Their specifics are summarized in Table 1. All cryogenic valves are on the supply header-side.

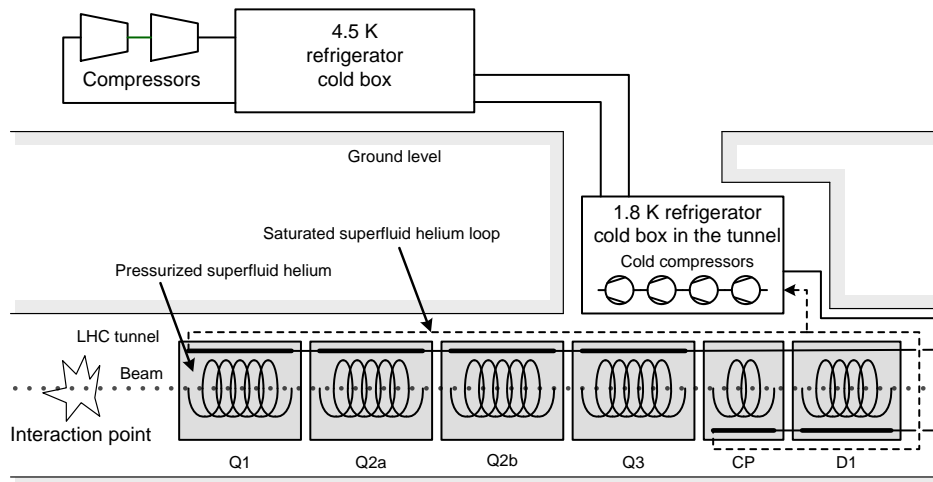

Figure 1: Architecture of the cooling by using superfluid helium. Lowest point on the left.

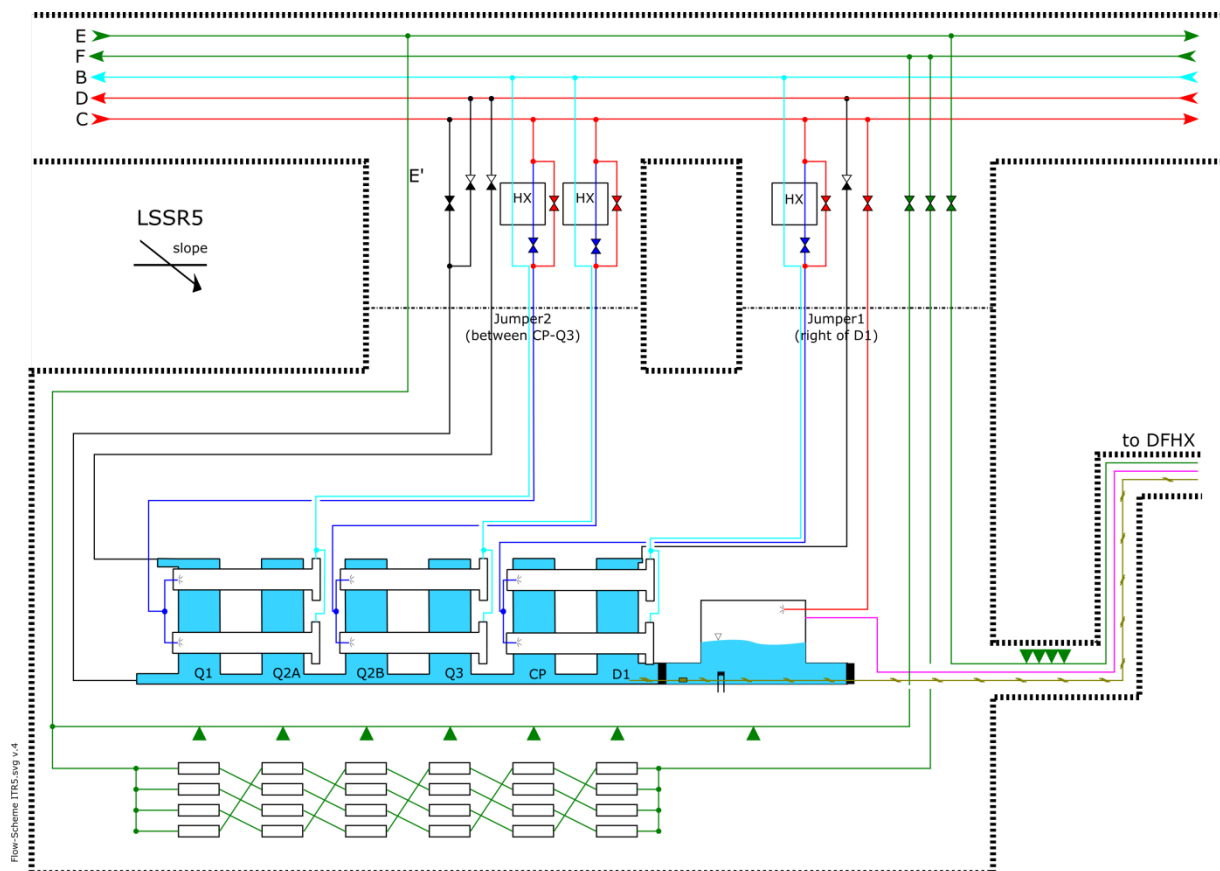

Figure 2: Flow diagram for inner triplet, right of IP5. Lowest point on the right

Table 1: Cryogen supply header (values non definitive).

Header	Nominal Temperature	Nominal Pressure	Design Pressure	Comment
B	1.9 K	17 mbar	5 bar	Low pressure HeII pumping
C	5 K	3.5 bar	20 bar	Supply for HeII-cooling, cool-down & fill supply, superconducting link interface-box
D	60 K – 80 K	1.3 bar	25 bar	Quench line, cool-down & fill return
E	40 K	20 bar	25 bar	Thermal screen & beam screen supply
F	60 K	19 bar	25 bar	Thermal screen & beam screen return

Due to constraints on magnet design, the bayonet heat exchanger can be made to be continuous only through the quadrupole magnets or through the corrector package and dipole. The size and number of heat exchangers is determined by the maximum vapour velocity of 7 m/s above which the heat exchangers do not function anymore and the total available heat exchange area, when they are wetted over their full length. For the quadrupole heat exchangers, the vapour velocity limit is the more stringent condition and is met if one uses two heat exchangers in parallel with inner diameters greater than 68 mm and lengths limited to two quadrupoles in series. As a consequence the flow diagram exhibits three sets of bayonet heat exchanger cooling-units (D1+CP, Q3+Q2b, Q2a+Q1), each with their own supply and low vapour pressure return. These supply and return are forcibly proper to the cooling loops such as to keep the counter flow heat exchangers, situated on the cryogenic supply headers' side, balanced. Each of these cooling loops integrates a phase separator at its end. These have to absorb the liquid present in the bayonet heat exchangers in case magnet quenches would drive it out. The liquid volumes to accumulate, without obstructing the low-vapour pressure return inlet, are estimated to be 12.5 ℓ for each of the quadrupole cooling loops and 5.5 ℓ for the D1+CP cooling loop.

The heat exchangers themselves are smooth pipes, to be made of copper to assure proper heat conduction across the walls. A wall thickness of about 3 mm is required to sustain the external design pressures of 20 bar. With, in addition, an annular space of 1.5 mm between the HX and the yoke to allow contact area of the pressurized superfluid helium on the coil-side, the yoke-hole size required is 77 mm minimum. With this configuration one set of parallel quadrupole heat exchangers can safely extract about 400 W. Thus two sets of parallel heat exchangers together, one set for Q1+Q2a and one set for Q2b+Q3, remove about 800 W from the magnets. The 77 mm yoke-hole size is compatible with the mechanical design of the magnet, but should not be increased otherwise one would need to increase as well the overall diameter of the cold mass. Coping with the remaining 250 W is to be done via active cooling of the D1 and CP. Two parallel bayonet heat exchangers of 51 mm ID through D1 and CP are foreseen, requiring yoke holes of 60 mm diameter.

For correct functioning of the two-phase heat exchanger configuration, heat must be given some freedom to redistribute along the length of the cold-masses. This is no hard criterion, and a free longitudinal area of $\geq 150 \text{ cm}^2$ through the Q1, Q2a, Q2b, Q3, and their

interconnections and $\geq 100 \text{ cm}^2$ through D1, CP and their interconnections are deemed to be sufficient.

At present two pressure relief devices are foreseen as safety in case of sudden energy release to the cold mass helium due to either magnet quenches or catastrophic loss of insulation vacuum. The quench energies released are substantial for the MQXF – quadrupoles and D1 – dipole only. The energy per local helium volume for the magnets in the corrector package are so low that they can be absorbed by the surrounding helium without consequences for the neighbouring magnets (Figure 3 and Figure 4). In future, the safety aspects shall be addressed in detail so these devices can be dimensioned as needed.

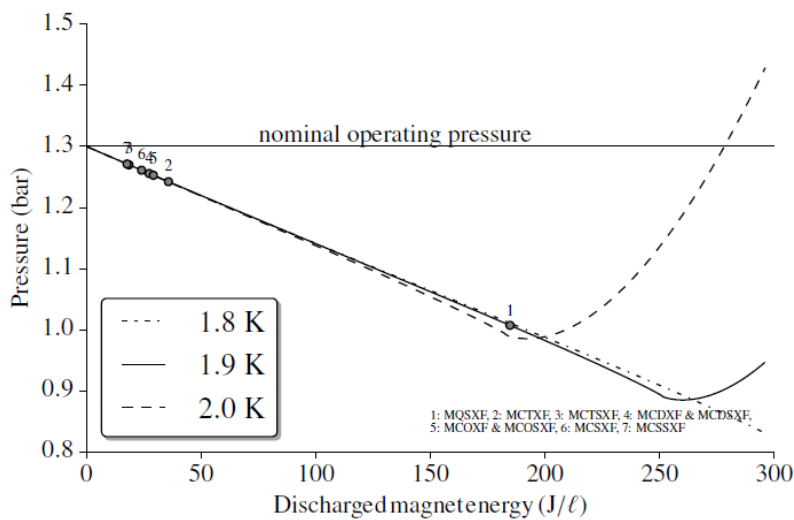

Figure 3: Isochoric pressure rise for corrector magnets

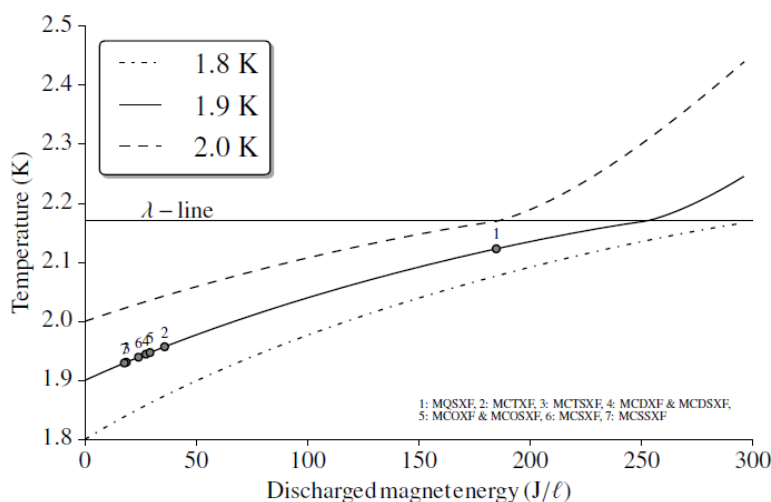

Figure 4: Isochoric temperature rise for corrector magnets

3.2. COOLING BY SUPERFLUID HELIUM: RADIAL EXTRACTION

3.2.1. MQXF-quadrupoles

The Nb₃Sn quadrupole coils are fully impregnated, without any helium penetration. The heat loads from the coils and the beam-pipe area can only evacuate to the two heat exchangers by means of the pressurized HeII. To this end the cold mass design shall incorporate the necessary radial helium passages.

Figure 5 shows the typical heat flow path: out from the coil areas, through the annular spacing between cold bore and inner coil-block, and subsequently via free passages through the titanium insert and G10-alignment key and around the axial rods towards the cooling channels where the two-phase flow bayonet heat exchangers will be inserted. They will occupy the two-upper yoke-holes marked “Cooling channel”. Since only two of the four possible cooling channels will house bayonet heat exchangers, free helium paths interconnecting these four cooling channel holes shall be implemented in the cold mass design. Doing so allows for equilibrating the heat flows and increasing the heat extraction margins as a whole.

The annular space between cold bore and inner coil block is set at 1.5 mm and the free passage needed through the titanium insert and G10-alignment key should be of the order of 8 mm holes repeated every 40 mm – 50 mm along the length of the magnet. Magnet design is presently integrating 8 mm diameter holes every 50 mm. This value and repetition rate will be used in the temperature margin evaluation in subsequent paragraphs. Around the axial rods a free passage of 1.5 mm has to be guaranteed.

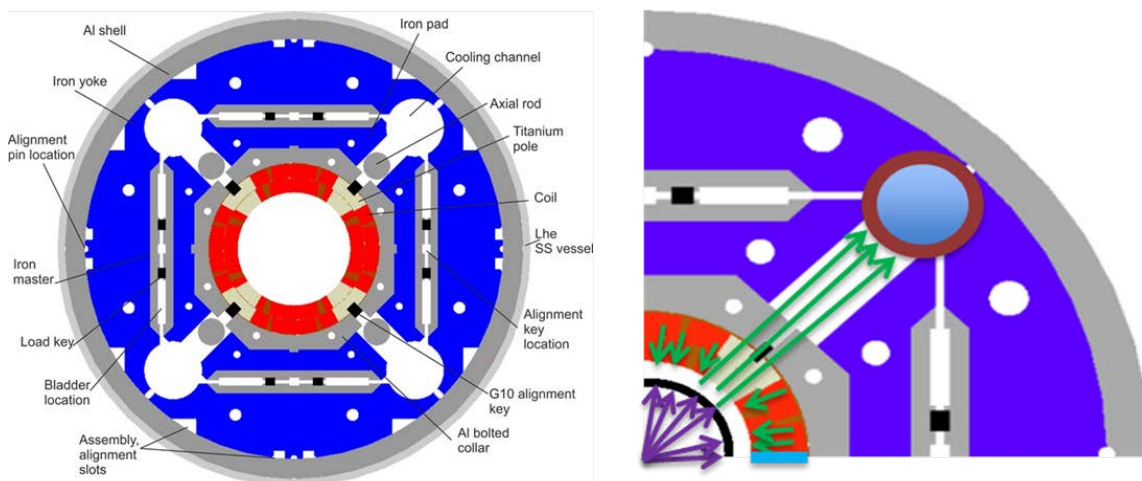

Figure 5: Heat flow paths from coil to one of the two-phase heat exchangers located in the upper right quadrant

3.2.2. D1-dipole

D1 has a single-layer coil, 4-split spacer collars and collared yoke by keying. Figure 6 shows a 3D-CAD of a 2 m-long model of D1. A major difference with MQXF is that D1 does not have cooling channels, but relies on the spacing of collars (96% packing factor) and yoke (98% packing factor), as well as the porosity of the NTi coils (0.118 % HeII) to allow for HeII cooling.

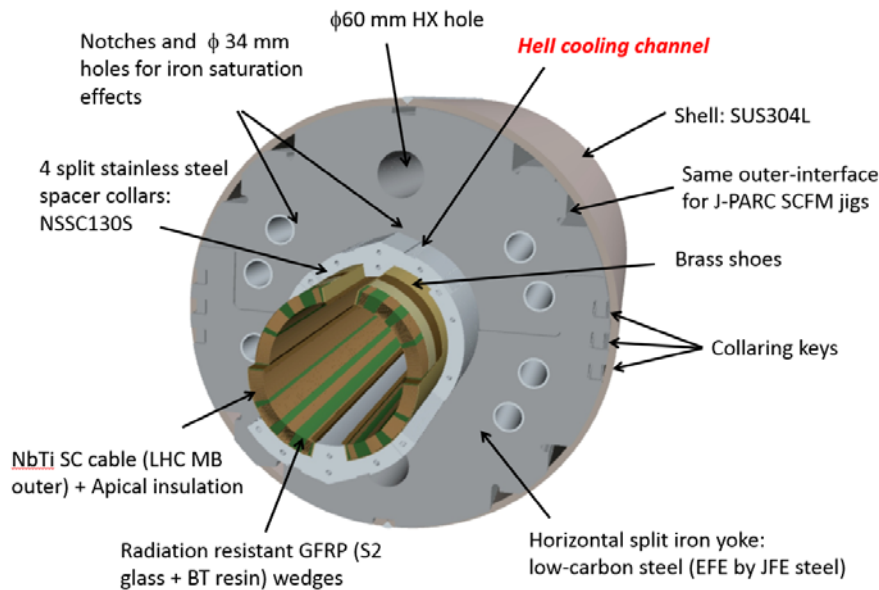

Figure 6: A 3D-CAD of a 2 m-long model of D1

3.3. SUMMARY OF MAIN COLD MASS REQUIREMENTS

Table 2: Summary of main cold mass requirements

Q1,Q2a,Q2b,Q3, including interconnects	no./rep.	size	unit	comment
Yoke hole for HX	2	77	(mm)	
HX inner diameter	2	68	(mm)	assuming 1.5 mm annular gap, 3 mm pipe-thickness
Yoke-HX annular gap	-	1.5	(mm)	
Phase separator	2	≥ 12.5	(ℓ)	
Total free longitudinal area	-	≥ 150	(cm ²)	for cooling stabilization and sharing with CP-D1
beam-pipe - inner layer annular gap	-	1.5	(mm)	part of heat extraction path
annular to heat exchanger	every 40 - 50 mm	8	(mm)	via Titanium insert, G10 alignment keys
annular to heat exchanger	-	1.5	(mm)	Passage around axial rods
cooling channel interconnects	4			98 % packing factor equivalent
D1, CP, including interconnects				
Yoke hole for HX	2	60	(mm)	
HX inner diameter	2	51	(mm)	assuming 1.5 mm annular gap, 3 mm pipe-thickness
Yoke-HX annular gap	-	1.5	(mm)	
Phase separator	1	≥ 5.5	(ℓ)	
Total free longitudinal area	-	≥ 100	(cm ²)	for cooling stabilization and sharing with Q1-Q3
beam-pipe - inner layer annular gap	-	1.5	(mm)	part of heat extraction path
radial passages	-			98 % packing factor equivalent

4. THERMAL PERFORMANCE EVALUATION

4.1. THERMAL MODEL AND INPUT CONDITIONS

Development of a generic CFD toolkit for heat flows in combined solid – liquid systems was launched in parallel to the inner triplet magnet designs to enable a detailed thermal evaluation and provide timely feedback [9]. The modelisation results assume heat load distributions for Q1, Q21, Q2b, Q3 and D1 over the magnet cross-sections at the most unfavourable locations

(Figure 7 and Figure 8) [3]. These power deposition density maps, as used in the modelisations, have a radial resolution of 3 mm. When averaged over the cable radial size (about 15 mm) peak power densities of about 4 mW/cm³ for MQXF quadrupoles and 1.5 mW/cm³ for D1 are reached.

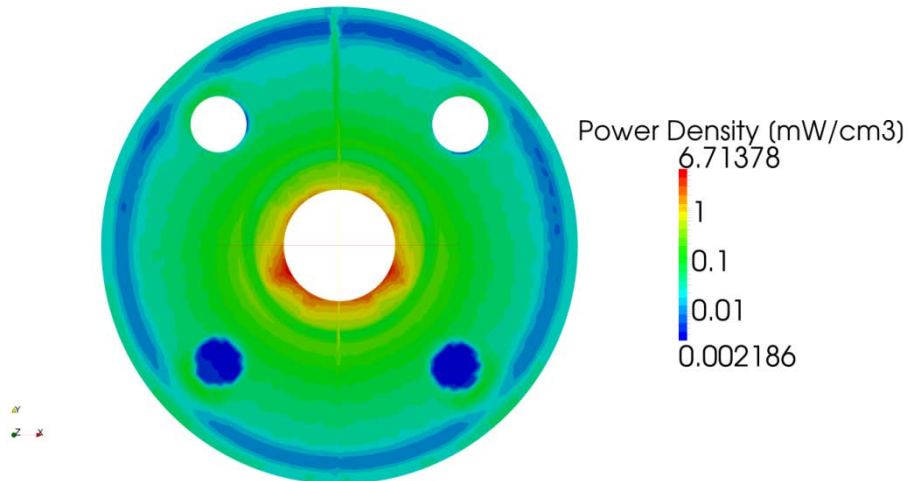

Figure 7: Power deposition map for Q3 at ultimate peak luminosity, radial resolution 3 mm

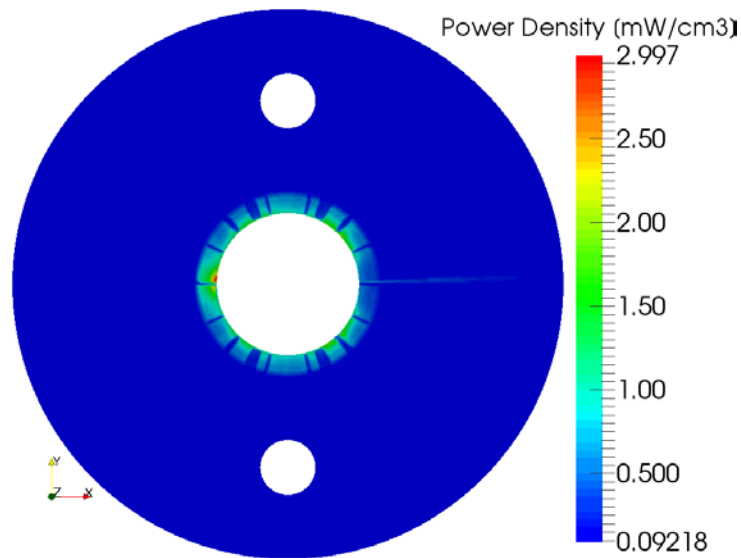

Figure 8: Power deposition map for D1, radial resolution 3 mm

These power deposition maps are used as modelling input to produce temperature distribution maps of the cold masses. The results are then converted into temperature margin maps by comparison with the respective current sharing maps, calculated on an assumed homogeneous temperature distribution of 1.9 K (Figure 9 and Figure 10).

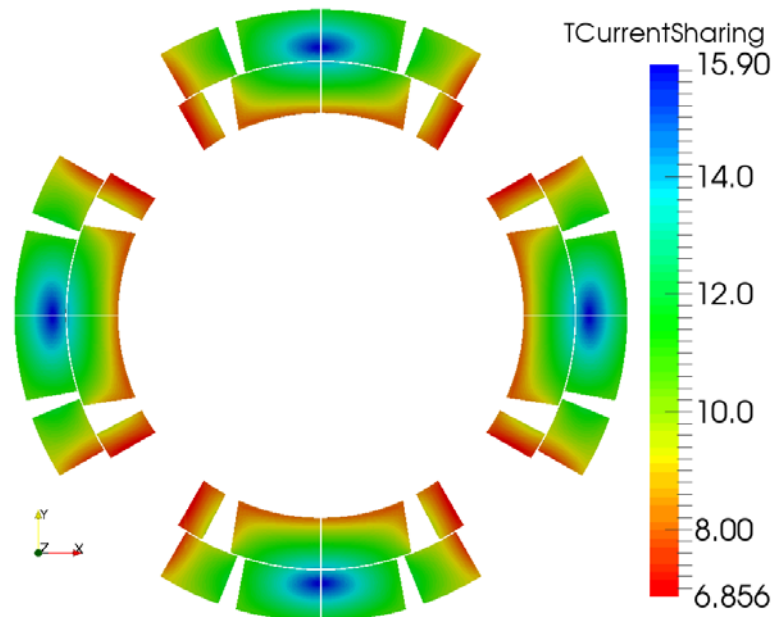

Figure 9: Current sharing map of MQXF quadrupole

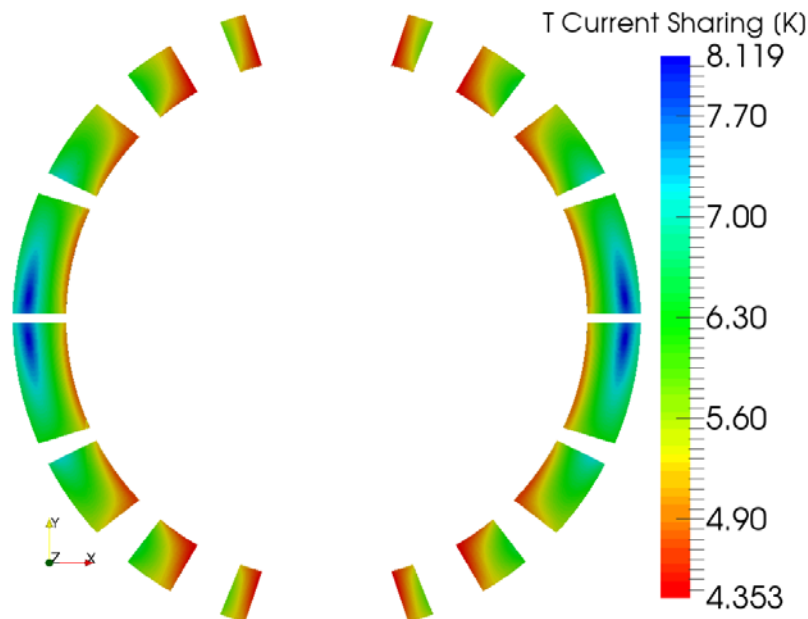

Figure 10: Current sharing map of D1 dipole

The MQXF-quadrupole and D1-dipole coil materials were implemented with the coil pack details as shown in Figure 11 and Figure 12. “Porous” quench heaters are assumed to be placed on the MQXF inner coil layer (Figure 13). They were modelled as accurately as possible. This will give conservative results (as these are right in the heat extraction path), should the inner layer quench heater later be retracted from the quench protection scheme. The porous Nb-Ti Rutherford cable of D1 was conservatively modelled, not taking fully into account the helium inside. Detailed listings of materials used for D1 were provided by T. Nakamoto from KEK.

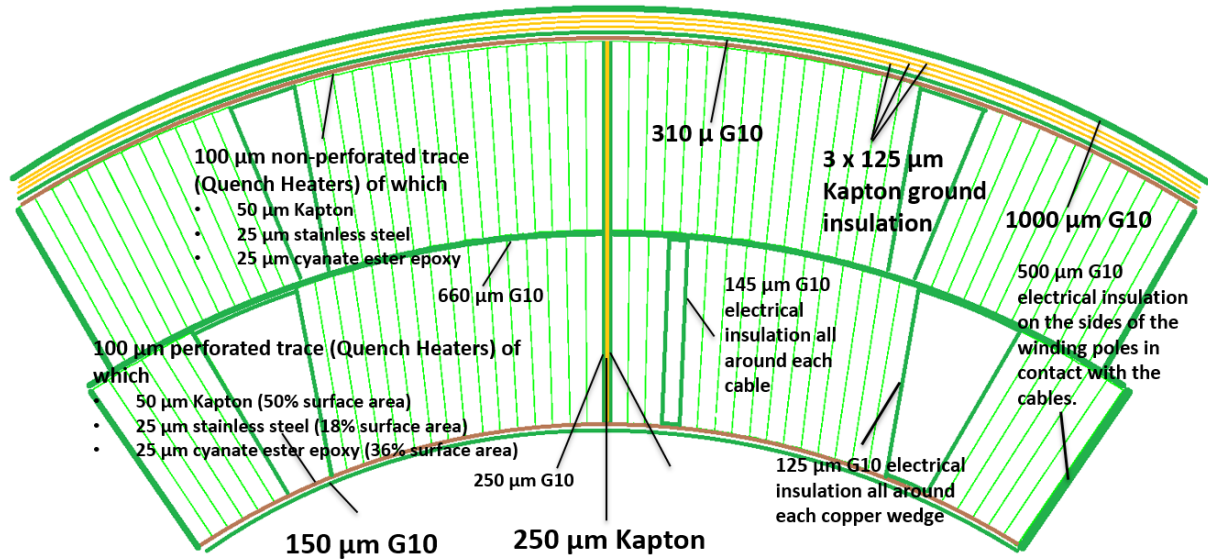

Figure 11: MQXF - quadrupole Nb_3Sn coil materials assumed for the calculations.

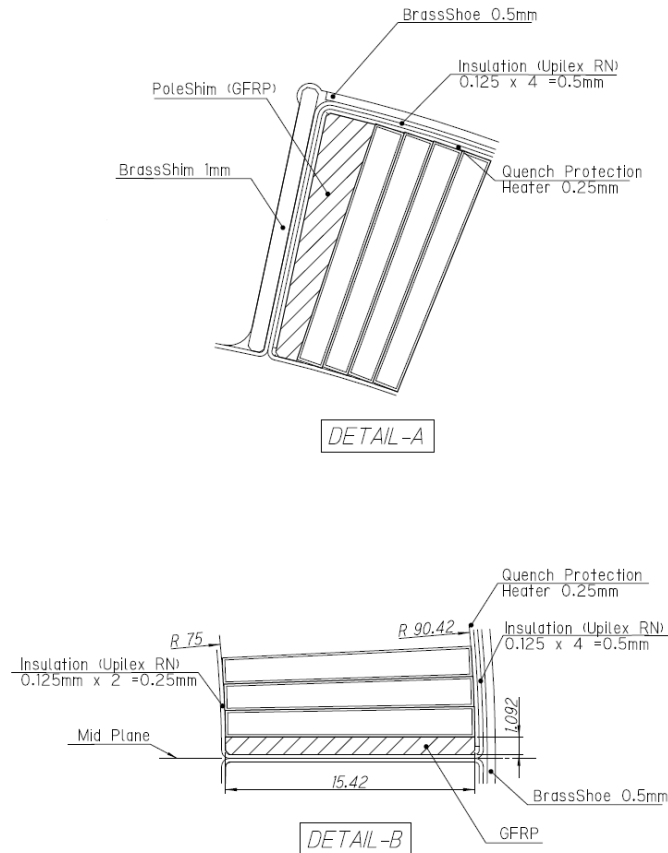

Figure 12: D1-dipole Nb-Ti coil materials assumed for the calculations.

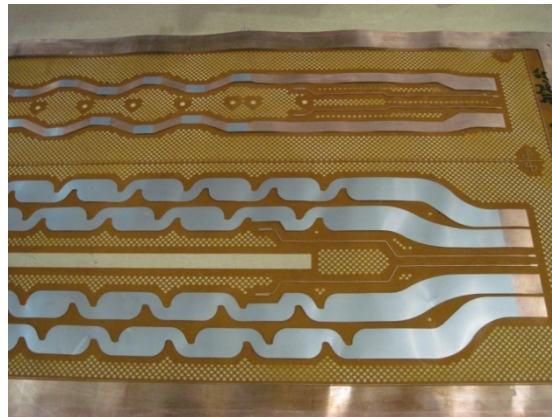

Figure 13: Perforated kapton quench heaters.

4.2. STEADY STATE TEMPERATURE DISTRIBUTION, TEMPERATURE MARGIN AND LOCAL MAXIMUM-SUSTAINABLE LOAD

4.2.1. MQXF-quadrupole

Figure 14 to Figure 17 show the temperature and temperature-margin maps with their respective zooms. These were all calculated assuming a 1.9 K cold source (bayonet heat exchanger) temperature. Although the highest temperatures of about 3.15 K are reached in the outer coil layer, when combined with the current sharing maps, we find the most critical zones at the inner layer pole edges. There, the temperature margin goes down to about 4.1 K. Note that The value of 4.1 K is reached in a small fraction of the coil (see Figure 17), and further optimization of the beam screen W absorber could remove this singularity and bring the temperature margin above 5 K all over the coil.

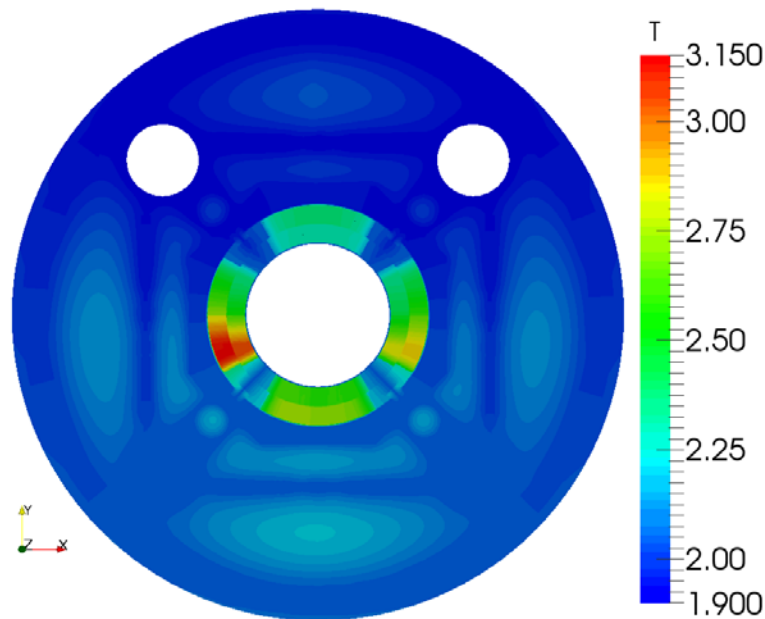

Figure 14: MQXF quadrupole temperature map; full section.

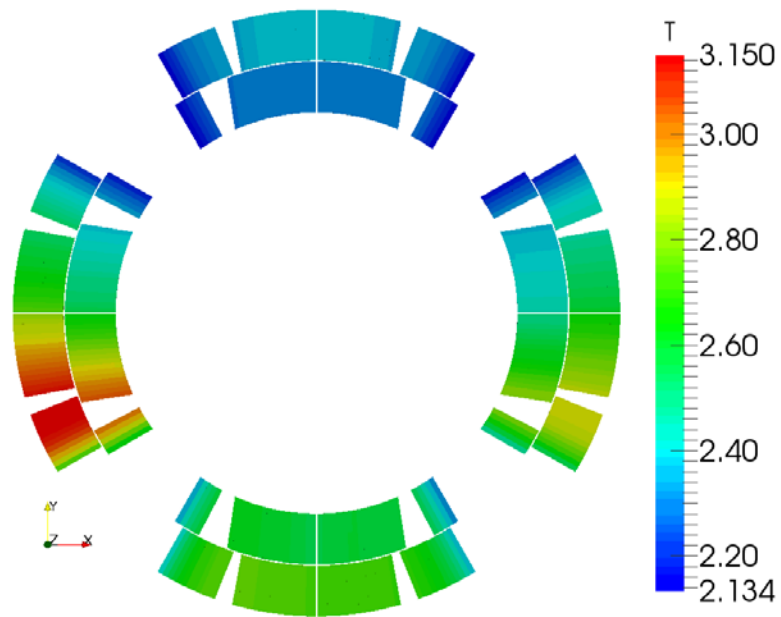

Figure 15: MQXF quadrupole temperature map; coil section.

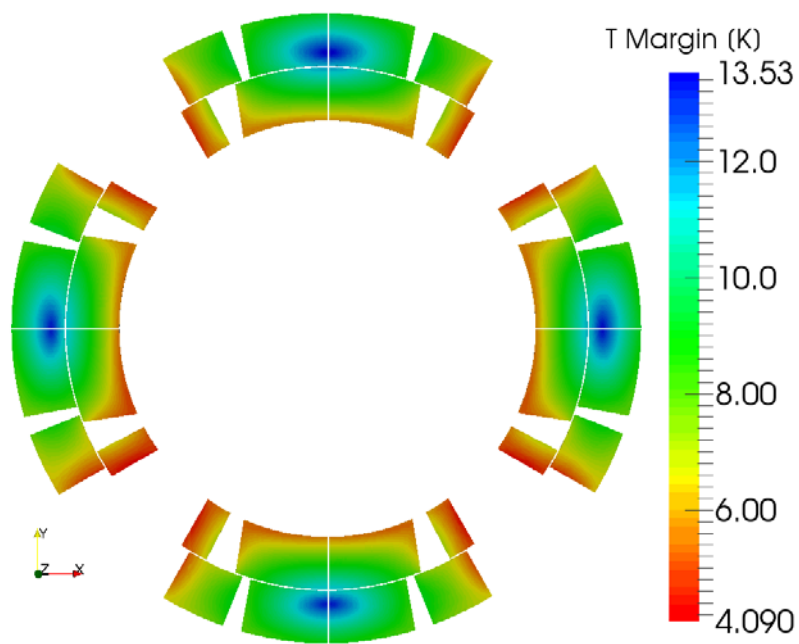

Figure 16: MQXF quadrupole temperature-margin map.

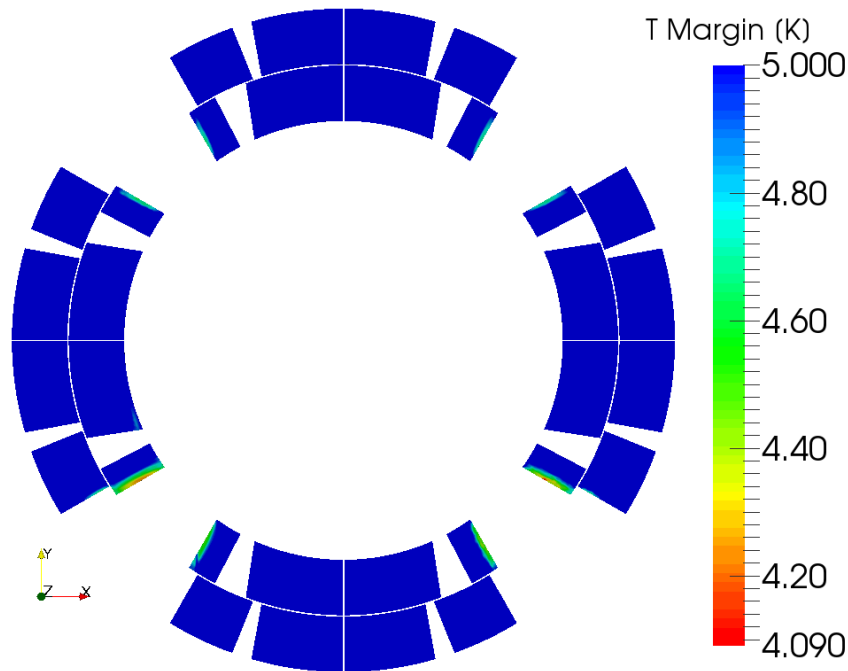

Figure 17: MQXF quadrupole temperature-margin map, capped off at 5 K to expose the critical zones.

The robustness of the MQXF thermal design is addressed by steady state local power deposit values that the coil can withstand without either the cooling breaking down or the cable reaching a temperature margin of 0 K. We found that in these steady state cases the local cooling break-down occurs first. Figure 18 shows that locally we can sustain powers from 56 mW/cm³ at 1.9 K down to 19 mW/cm³ at 2.1 K bayonet heat exchanger temperature. This constitutes a factor 8 at 1.9 K down to 3 at 2.1 K with respect to the expected peak load of 6.7 mW/cm³ at ultimate luminosity.

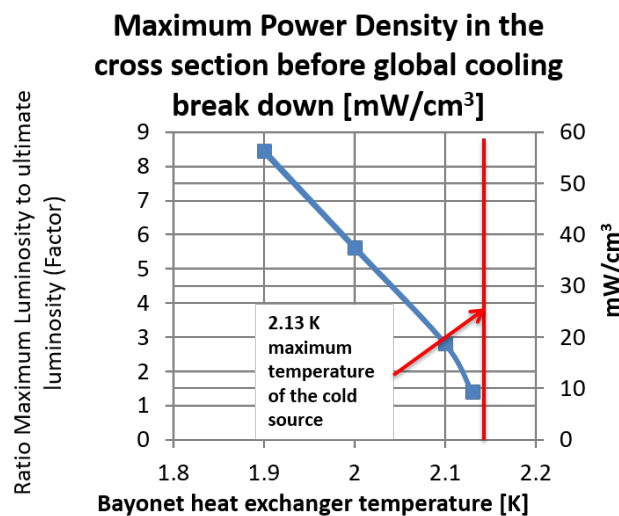

Figure 18: MQXF - quadrupole steady state power margin.

4.2.2. D1 dipole

Figure 19 to Figure 21 show the temperature and temperature-margin maps with their respective zooms. These were all calculated assuming a 1.9 K cold source (bayonet heat exchanger) temperature. Highest temperatures of about 2.05 K are reached. When combined with the current sharing maps, we find the most critical zones near the poles. There, the temperature margin goes down to about 2.4 K. Further optimization of the W-absorbers could bring this margin higher.

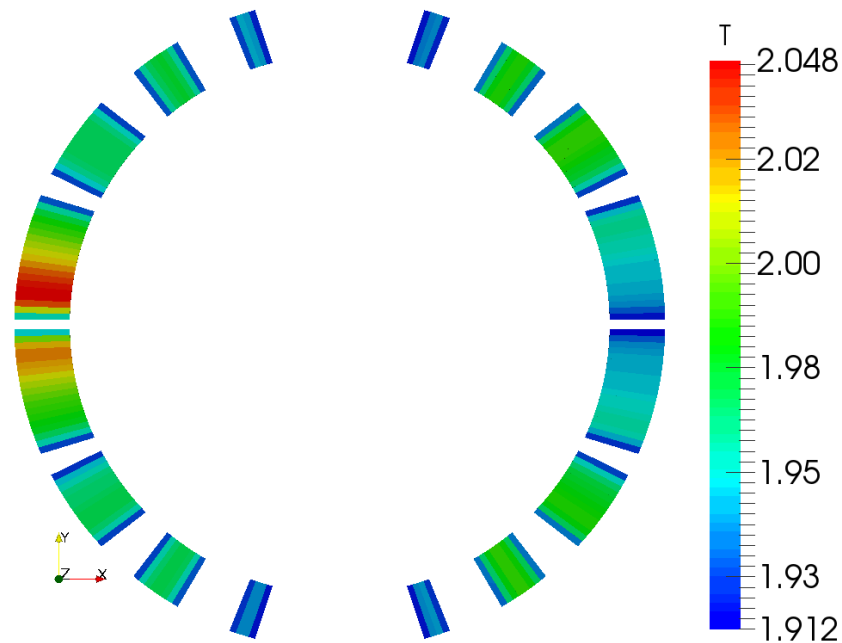

Figure 19: D1 – dipole temperature map

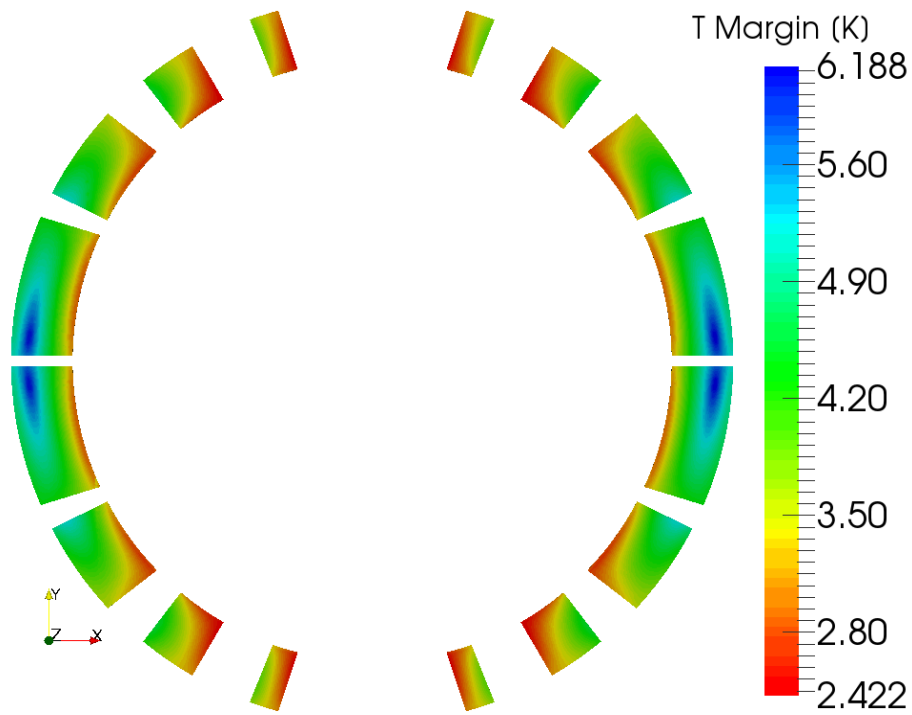

Figure 20: D1 - dipole temperature-margin map.

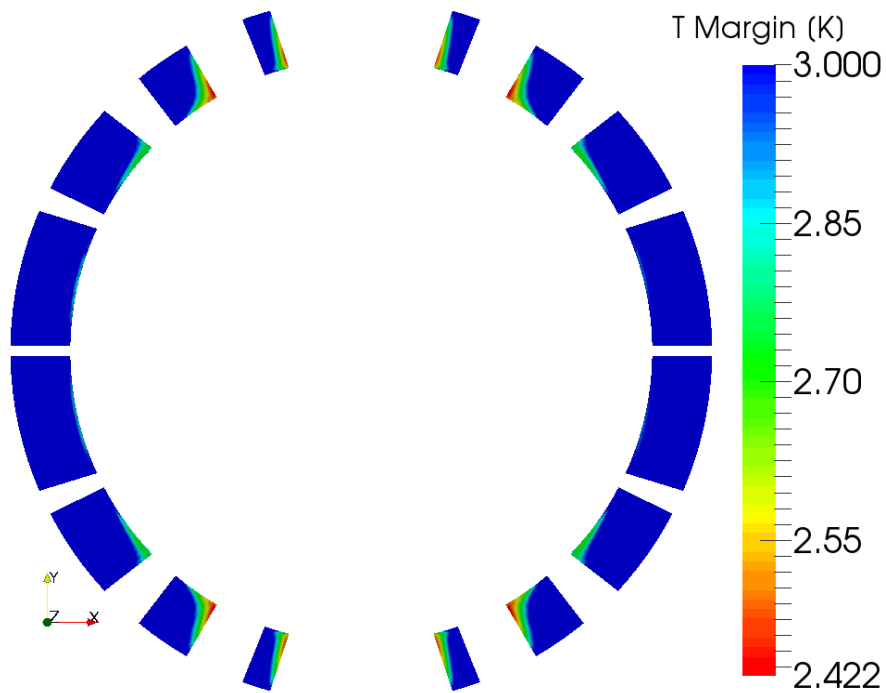

Figure 21: D1 - dipole temperature-margin map, capped off at 3.0 K to expose the critical zones.

4.3. MAXIMUM TRANSIENT POWER EXTRACTION LIMITS OF THE MQXF DESIGN (MQE/TAU)

In paragraph 4.2.1 we showed that the MQXF quadrupole can sustain local powers from 56 mW/cm^3 at 1.9 K down to 19 mW/cm^3 at 2.1 K bayonet heat exchanger temperature, limited due to local cooling break-down. The coil can withstand higher values for short duration pulses. We applied the model in transient mode to gradually shorter heat pulses until break-down due to reaching a temperature margin of 0 K was reached. Figure 22 and Figure 23 illustrate the rise in sustainable power pulses, expressed as Minimum Quench Energy per pulse duration (MQE/ τ). For reference, the adiabatic limits for cable and strands only are shown as well. It is found that the temperature margin of 0 K is reached for 100 mW/cm^3 at pulse duration of 2.3 s, when having the bayonet heat exchanger temperature at 1.9 K. This limit is due to cable insulation. It has to be compared to the value of 56 mW/cm^3 for longer duration pulses caused by local cooling break down due to helium channel sizing.

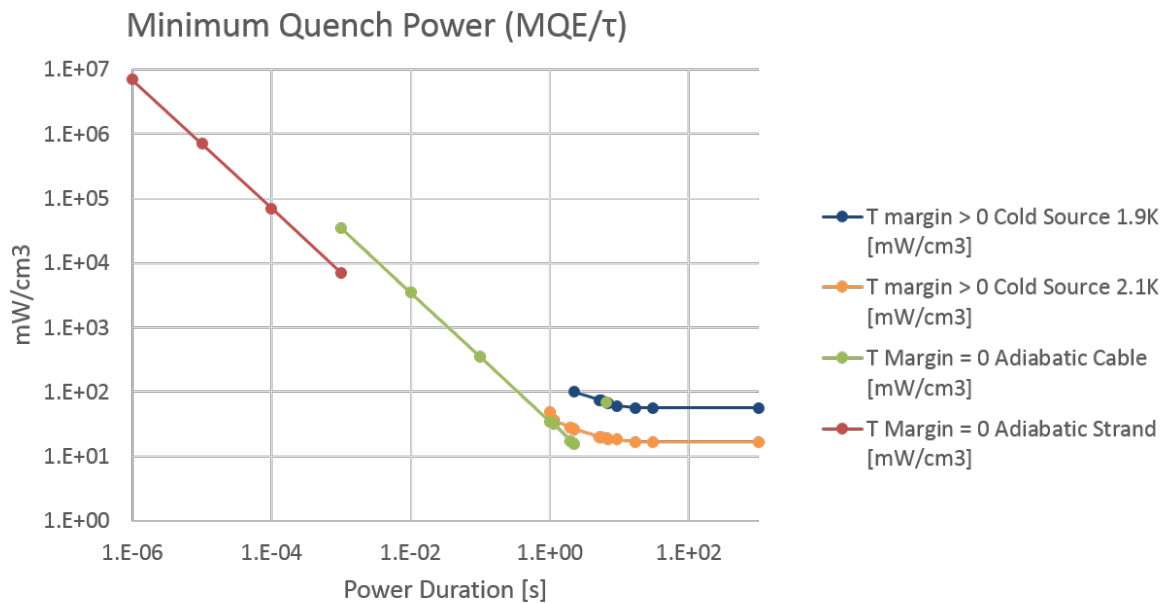

Figure 22: MQXF - quadrupole minimum quench power: log scale.

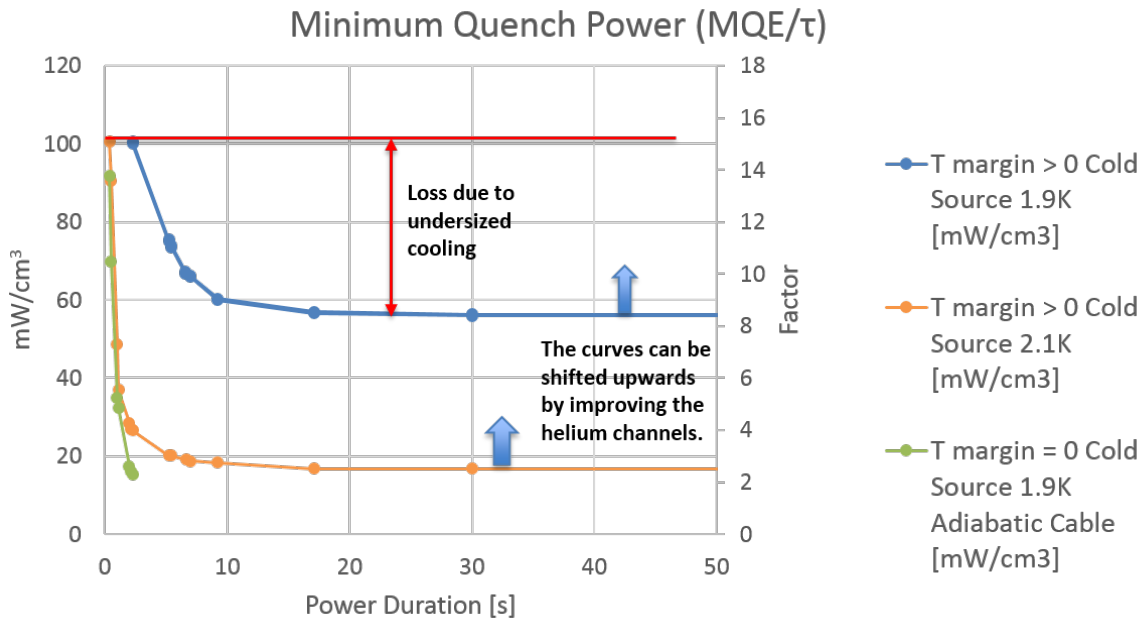

Figure 23: MQXF- quadrupole minimum quench power: linear scale.

5. CONCLUSIONS

The general cooling layout and infrastructure needed to extract more than one kW of power at 1.9 K from the 57 m long string of magnets (Q1 up to D1) is similar to proven LHC configurations. The 1.9 K specific sizing requirements are shown to be feasible within the available cold mass space as long as the two-phase cooling loops are composed of two parallel bayonet heat exchangers and separated into three independent units, which together cover the full magnet string.

The requirements imposed on the cold mass design to enable cooling the inner triplets by superfluid helium have been integrated in the magnet design since the early stage of the design study. The design details enabling to radially conduct the power deposit due to debris from the interaction points from the coils towards the cold source have been gradually refined, and the combined effect on magnet performance is evaluated in terms of temperature margin of the magnets under full steady state heat load conditions and in terms of local maximum sustainable load; i.e. minimum quench energy (MQE). The resultant temperature margins as modelled for the MQXF – quadrupoles (4.1 K) and for the D1 – dipole (2.4 K) are within the acceptable range for safe operation. Improvement can be inferred from the temperature margin maps if the most critical zones so identified could be better shielded.

With the steady state cooling layout defined and the magnet performance quantified as fully acceptable one has now to address the thermo hydraulics due to transients. The exploration of the transition in MQE values from well cooled to partially-cooled and finally adiabatic would necessitate a refinement of the global cooling model developed so far. A safety analysis of pressure development after magnet quench or catastrophic insulation vacuum break down is necessary to define the safety strategy and quantify the safety devices.

6. REFERENCES

- [1] *High Luminosity Large Hadron Collider A description for the European Strategy Preparatory Group*, Rossi, L.; Brüning, O., CERN-ATS-2012-236
- [2] *Energy deposition on triplet and D1*, L. Esposito, Joint HiLumi LHC-LARP Annual Meeting 2014, Tsukuba, Japan,
- [3] *Recap of energy deposition*, F. Cerutti, WP3 Collaboration meeting, 21-08-2015
- [4] *Design Studies for the Low-Beta Quadrupoles for the LHC Luminosity Upgrade*, Todesco E., Allain H., Ambrosio G., Borgnolutti F., Cerutti F., Diedrich D., Esposito L., Felice H., Ferracin P., Sabbi G., Wanderer P., van Weelderren R., Applied Superconductivity, IEEE, Volume 23 (2013)
- [5] *Study of the Supercritical He Cooling: MS41*
- [6] *Study of the Superfluid He Cooling: MS42*
- [7] *The Cryogenic Design of the Phase I Upgrade Inner Triplet Magnets for LHC*, van Weelderren, R.; Vullierme, B.; Peterson, T., 23rd International Cryogenic Engineering Conference, Wroclaw, Poland, 19 - 23 Jul 2010
- [8] *Cooling Strings of Superconducting Devices below 2 K: The Helium II Bayonet Heat Exchanger*, Lebrun Ph.; Serio L.; Tavian L.; van Weelderren, R., Adv. Cryog. Eng., A: 43 (1998)
- [9] *Development and application of a generic CFD toolkit for heat flows in combined solid-liquid systems aimed at thermal design of HiLumi superconducting magnets*, G. Bozza, Z. M. Malecha, R. van Weelderren, CHATS on applied superconductivity, 2015, Bologna, Italy