



The ATLAS upgrade programme for LHC Run-3 and the HL-LHC

Edson Carquín López

Pontificia Universidad Católica de Chile

On behalf of the ATLAS Collaboration



LISHEP - 2015, August 2-8, Manaus, Brazil



The LHC Operation time-line (updated)



LHC / HL-LHC Plan

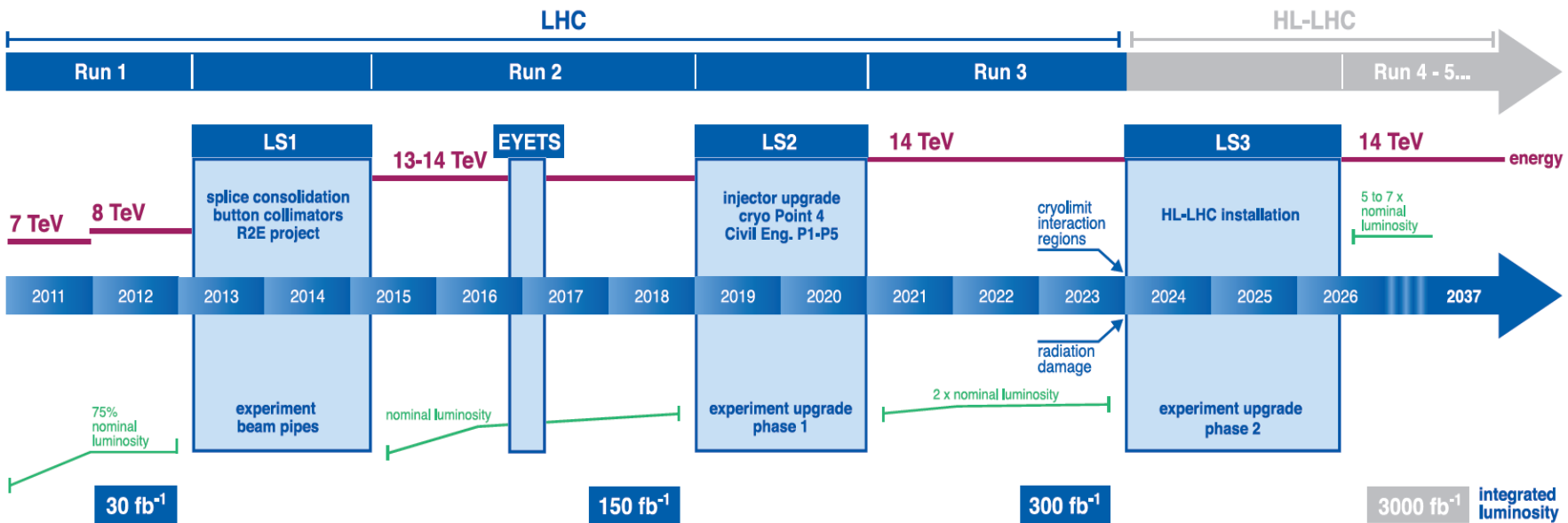

ATLAS UPGRADE



“Europe’s top priority should be the exploitation of the full potential of the LHC, including the high luminosity upgrade of the machine and the detectors with a view to collecting 10 times more data than in the initial design, by around 2030”



The LHC Operation time-line – Run 1 & 2



LHC / HL-LHC Plan

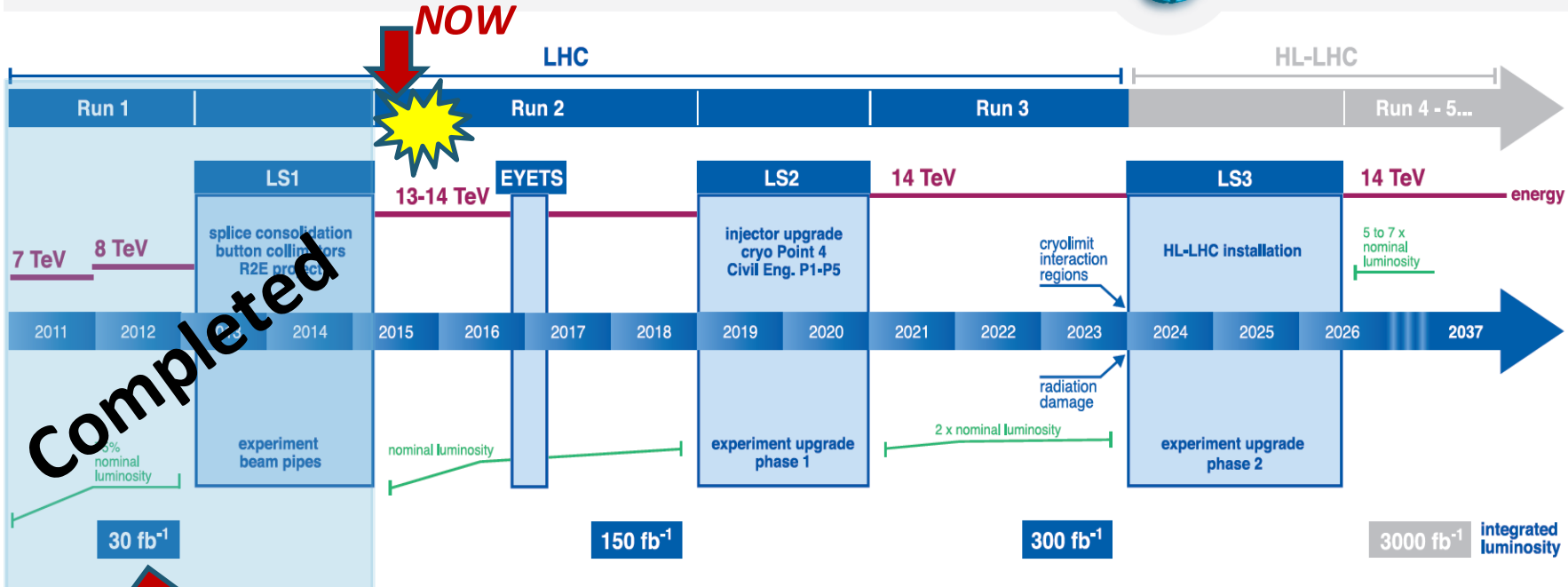

Completed

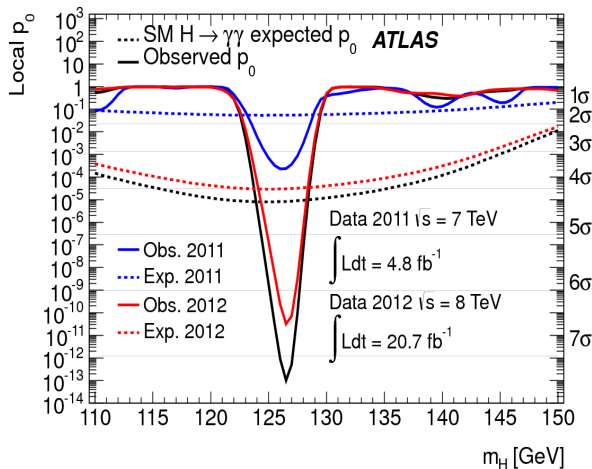

Englert & Higgs

Won the 2013 Nobel Prize



ATLAS UPGRADE



A flavour on the Run 2 (early physics & performance)



ATLAS talks showing early Run 2 results

Physics

- **ATLAS status and results in the dawn of Run-2**
- **B-physics and quarkonia results from ATLAS**
- **ATLAS results on top-quark physics**
- **QCD and electroweak physics with ATLAS**
- **Searches for supersymmetry with ATLAS**
- **Searches for exotic new phenomena with ATLAS**

Performance

- **The TileCal Energy Reconstruction for LHC Run2 and Future Perspectives**
- **The ATLAS Trigger System: Ready for Run-2**
- **The Upgrade of the ATLAS Electron and Photon Triggers towards LHC Run 2 and their Performance**

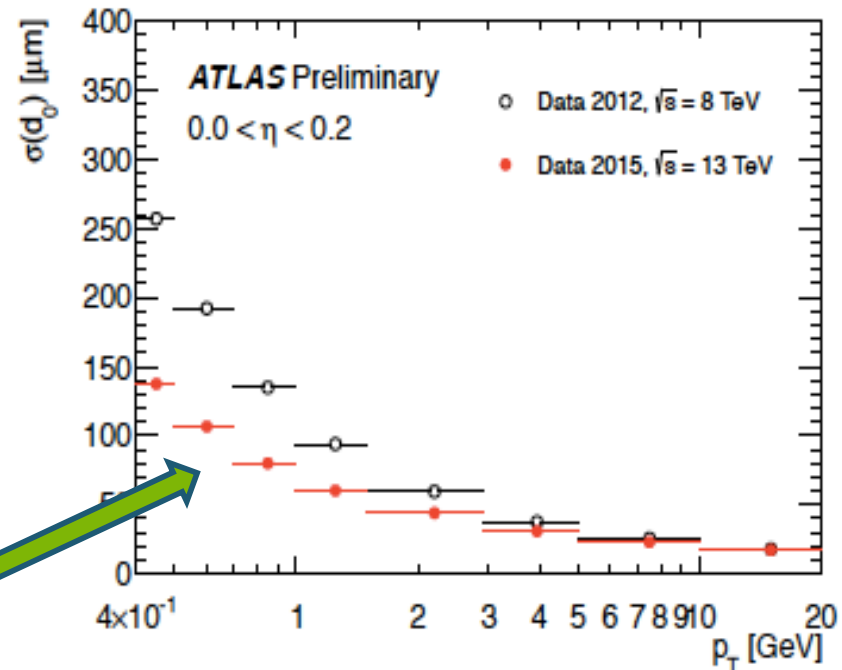

Improved track reconstruction with IBL



Main physics motivations for future LHC runs, beside many others...



ATLAS Simulation Preliminary

$\sqrt{s} = 14$ TeV: $\int L dt = 300 \text{ fb}^{-1}$; $\int L dt = 3000 \text{ fb}^{-1}$

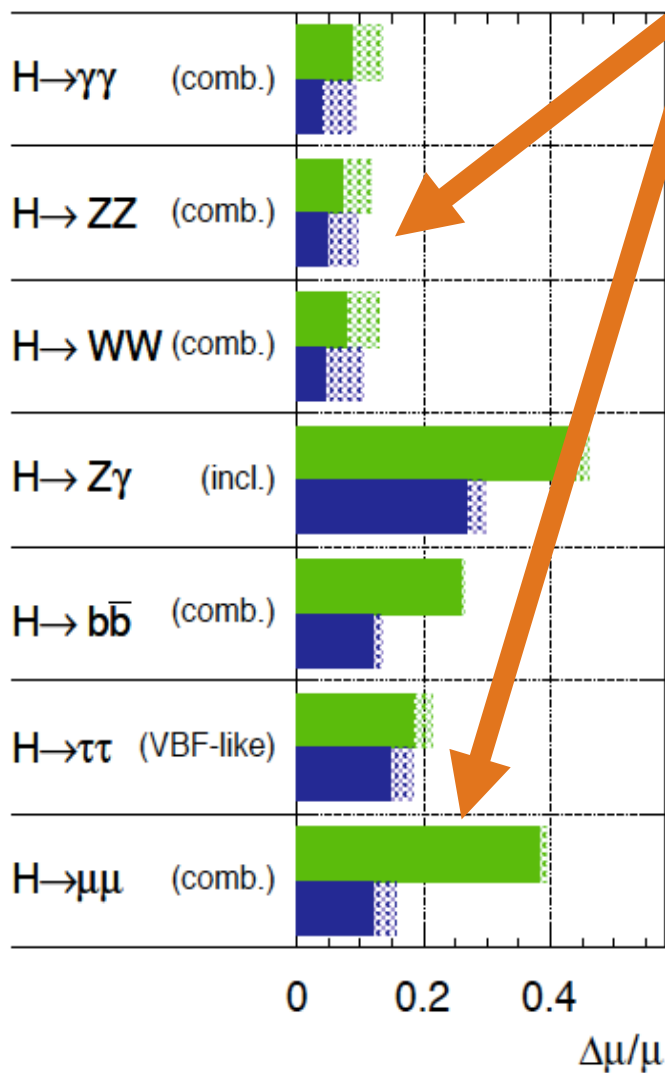

- ❖ Significant improvements in Higgs precision measurements (maintaining good performance for low-pT objects crucial !), access to Rare processes (H→μμ, and HH)

- ❖ Reach in SUSY particles searches significantly extended in Run 3 and the HL-LHC

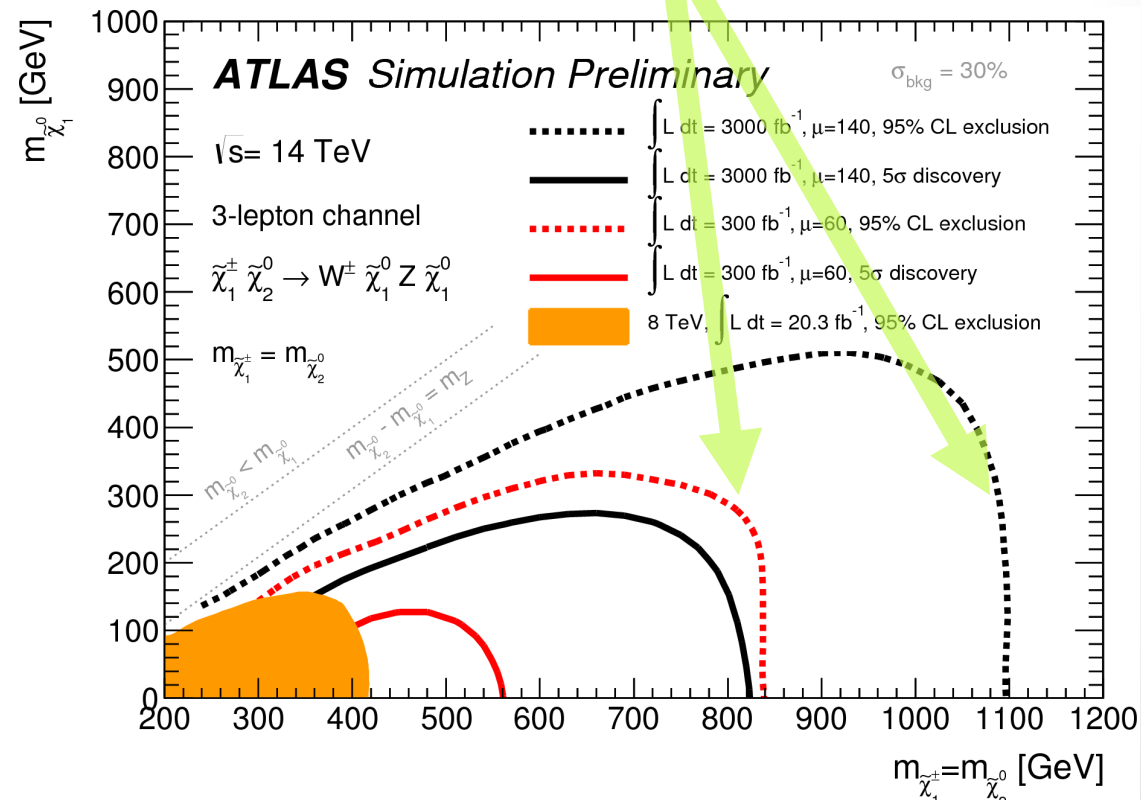

ATLAS UPGRADE



The LHC Operation time-line LS2 & Run 3



LHC / HL-LHC Plan

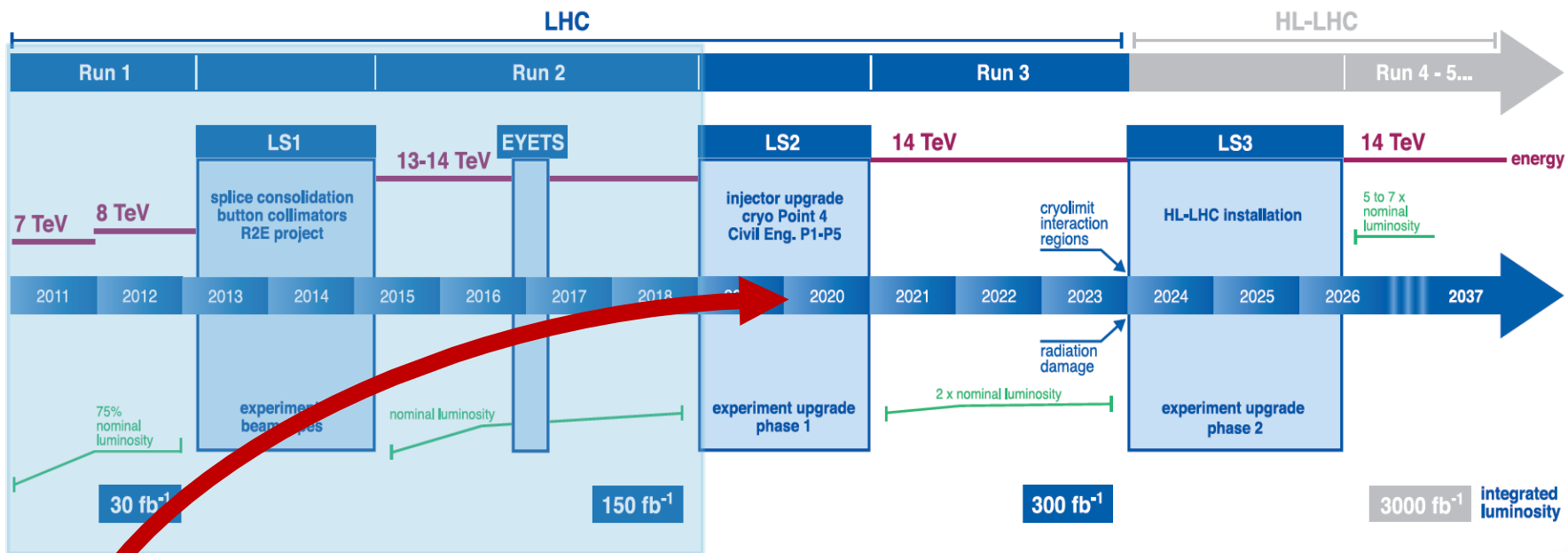

Significant changes will be made to the LHC injector and the ATLAS detector during the LS2 in order to reach and to cope respectively with the ultimate design luminosity of Phase-I



□ Run 3 Main ATLAS Upgrades

- **Improve of the L1 Trigger architecture.**
- **Triggering Fast TracKing (FTK) – 1.5 Trigger level.**
- **New Small Wheels (NSW) detector installation.**



L1 Trigger – LAr Super cells



Improve the trigger energy resolution and efficiency for selecting electrons, photons, leptons, jets, and missing transverse momentum (E_T^{miss}), while enhancing discrimination against backgrounds and fakes in an environment with high instantaneous luminosity.

Exploiting the higher-resolution and longitudinal shower information from the calorimeter for being used in the Level-1 trigger processors.

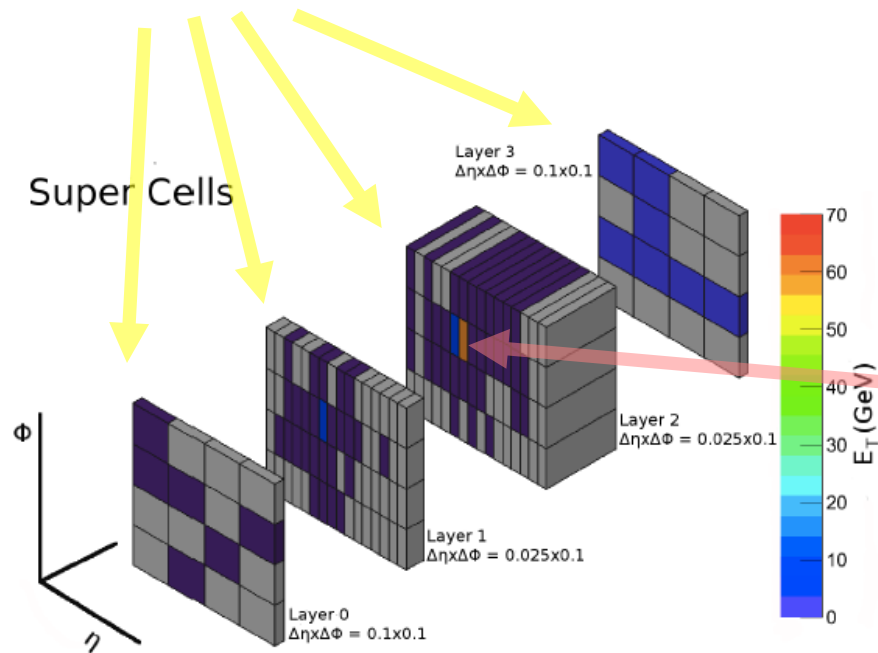

Electron (70 GeV E_T) seeing with finer granularity

Current Trigger Cell

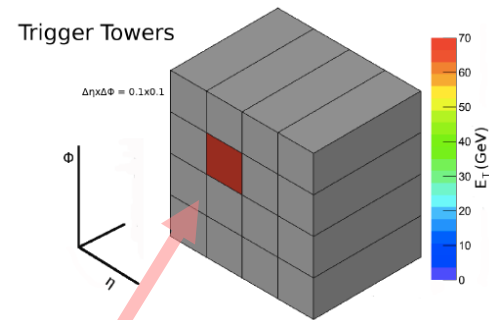

Electron (70 GeV E_T) at current L1 read-out

Allowing largest Jet rejection, crucial for efficient electron identification



L1Calo trigger read-out evolution



Significant improvements in the L1 trigger architecture already in place for the current *Run 2*.

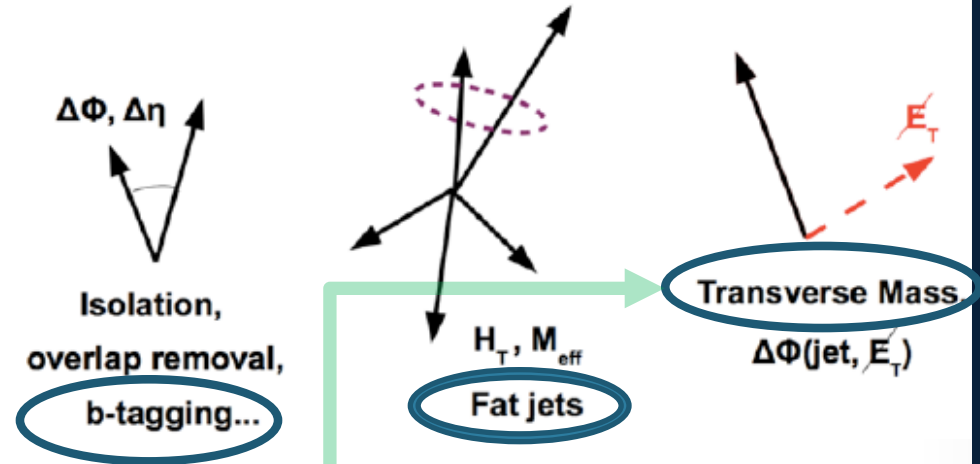
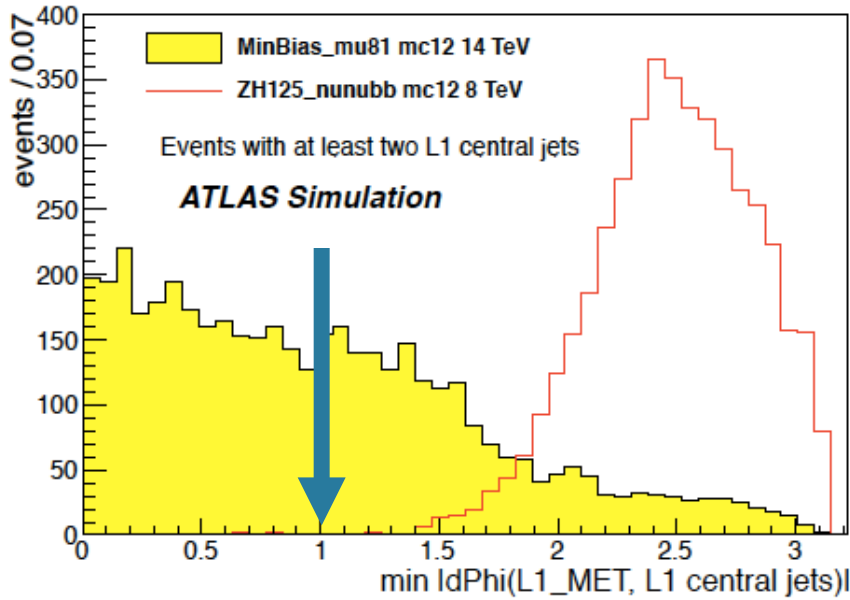

Allow a variety of topological cuts already at the L1 and a better control of pile-up.

Topological cuts provide good rejection against pile-up and a significant L1 rate reduction.

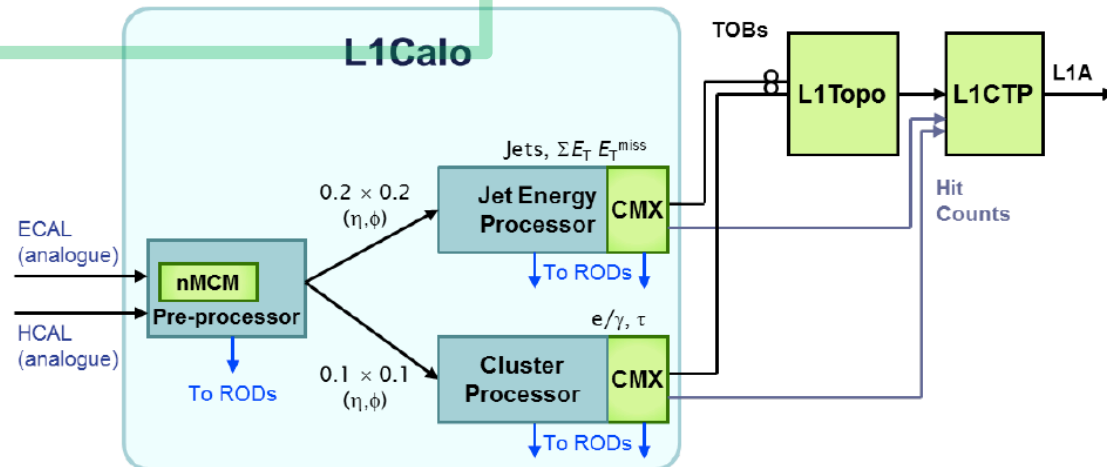

Run 2 upgrades in green.



L1Calo trigger read-out evolution



In addition, for the upcoming Run 3 there will be major upgrades in L1Calo, which will include the Electron, Jet and global FEXs, taking full advantage of the longitudinal shower shape information.

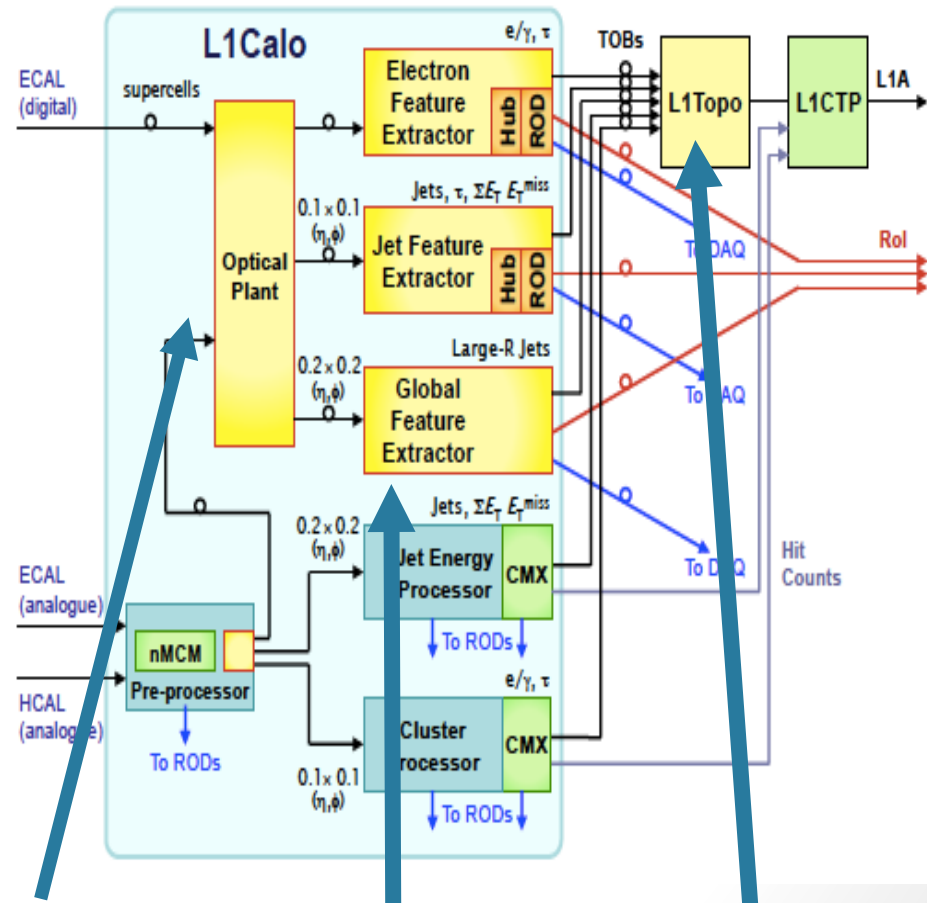
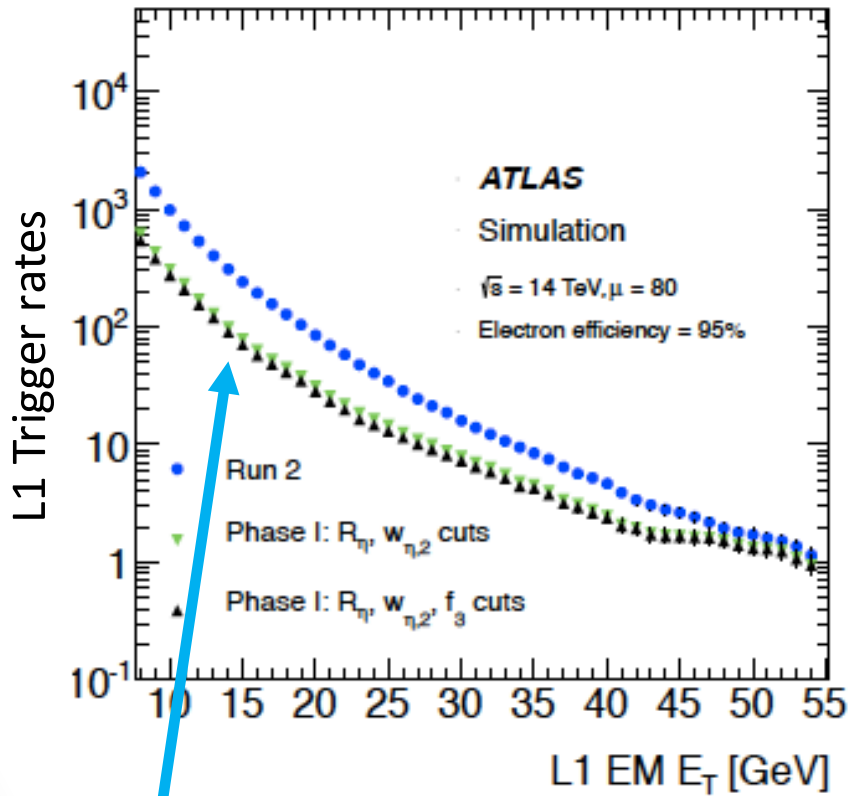

Significant reduction for low-pT particles compared with **Run-2**.

Run 3 upgrades, needed for taking full advantage of detailed information at the L1 Trigger level.



Triggering with Fast Tracking (FTK)



Dedicated FAST hardware-based track finder ($\sim 25 \mu\text{s}$) acting after L1 and providing full event tracking information for the HLT.

- ❖ FTK will take information from the ID silicon detectors, allowing an offline quality track reconstruction
- ❖ Additional tracking and vertexing information at the start of the HLT, good for handle pile-up.

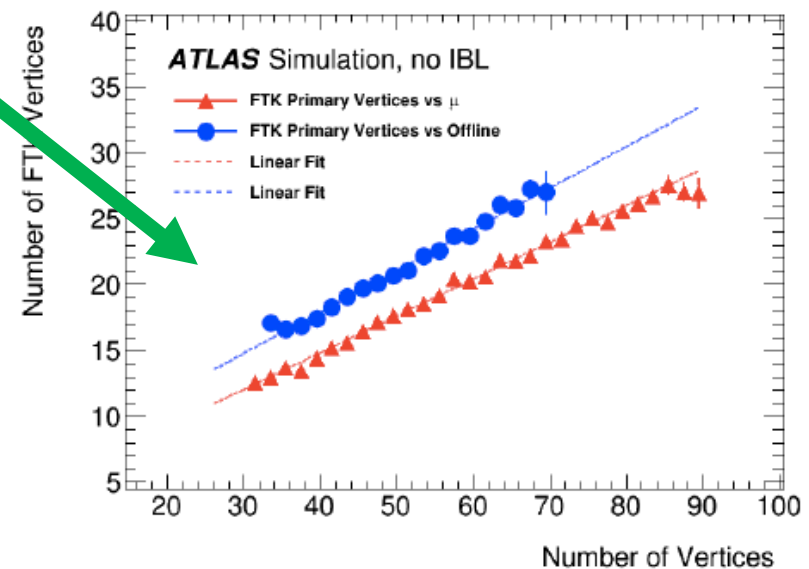
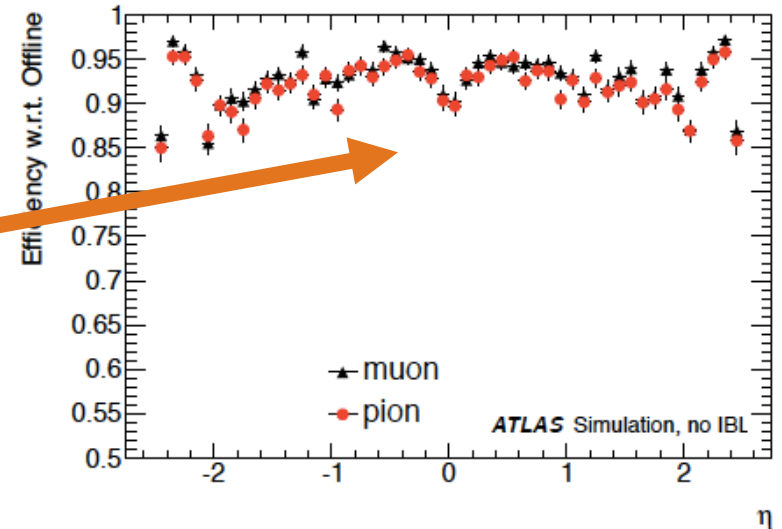
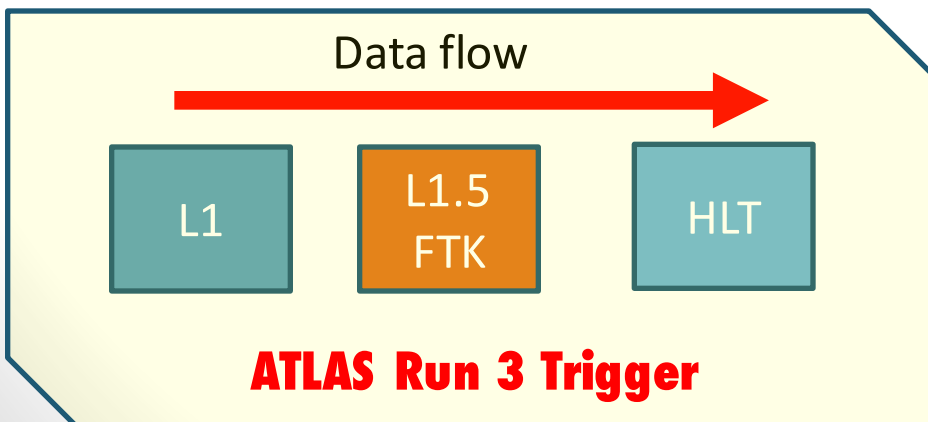



New S wheels for muon spectrometer

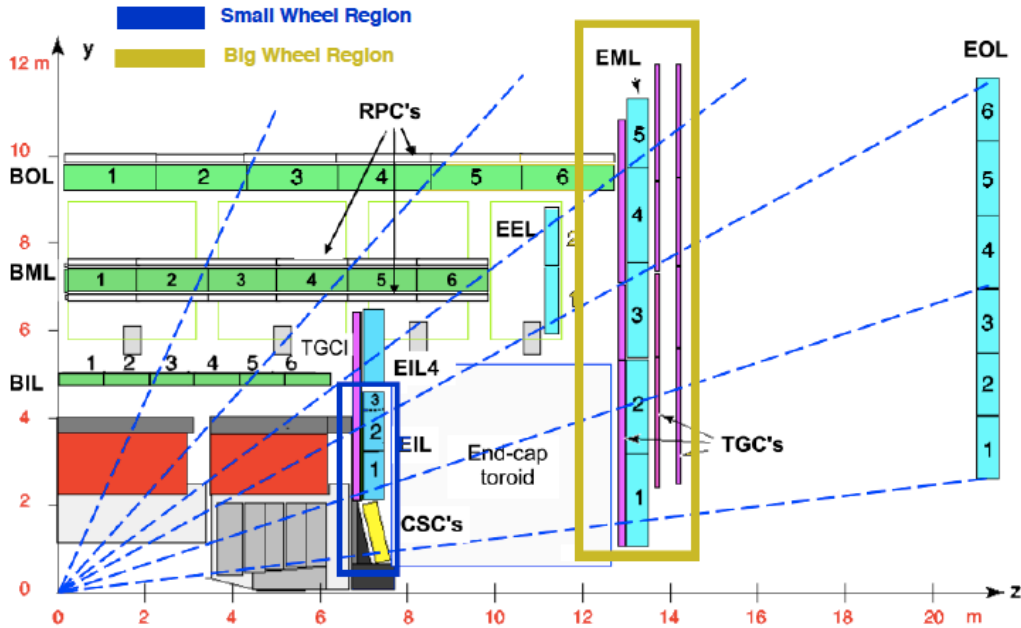

- After Run 2 will have to replace current muon system SW, due to radiation damage.
- New detector will help reducing the large background rate suffered in the muon detector end-caps.

TGC-MM-MM-TGC detector Sandwich

- Trigger chambers with angular resolution of ~ 1 mrad
- Precision offline tracking chambers with spatial resolution of $\sim 100 \mu\text{m}$
- Results in a very precise redundant system

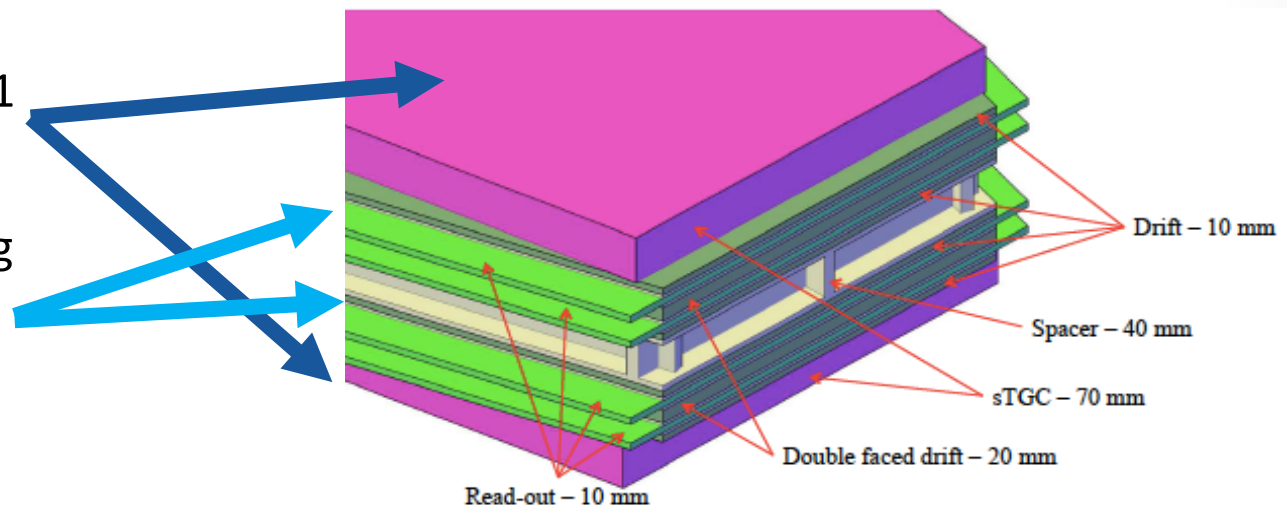

The new detector design satisfies the Phase-II requirements !



Forward Physics for ATLAS (AFP) at Run-2 and 3.



Physics with tagged forward protons @ ± 212 m from the IP.

❖ Primary goal is to study high rate diffractive physics in special low- μ runs.

❖ Eventually, the detector could work also on high $\langle\mu\rangle$ as an useful tool for searching new physics, but this option is still under investigation.



Central exclusive production (CEP)

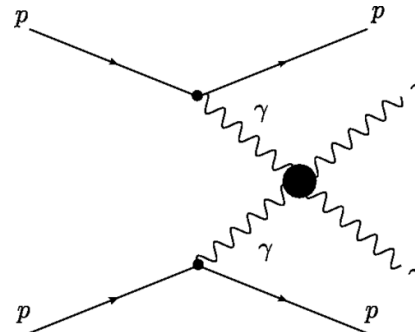

4-photon couplings are absent in the SM

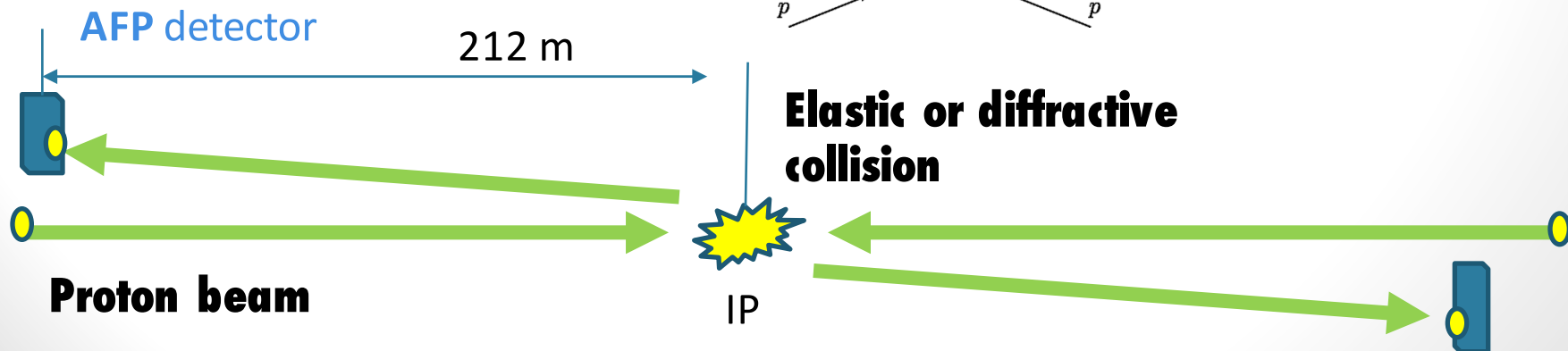



The LHC Operation time-line LS3 & HL-LHC stage after 2024..



LHC / HL-LHC Plan

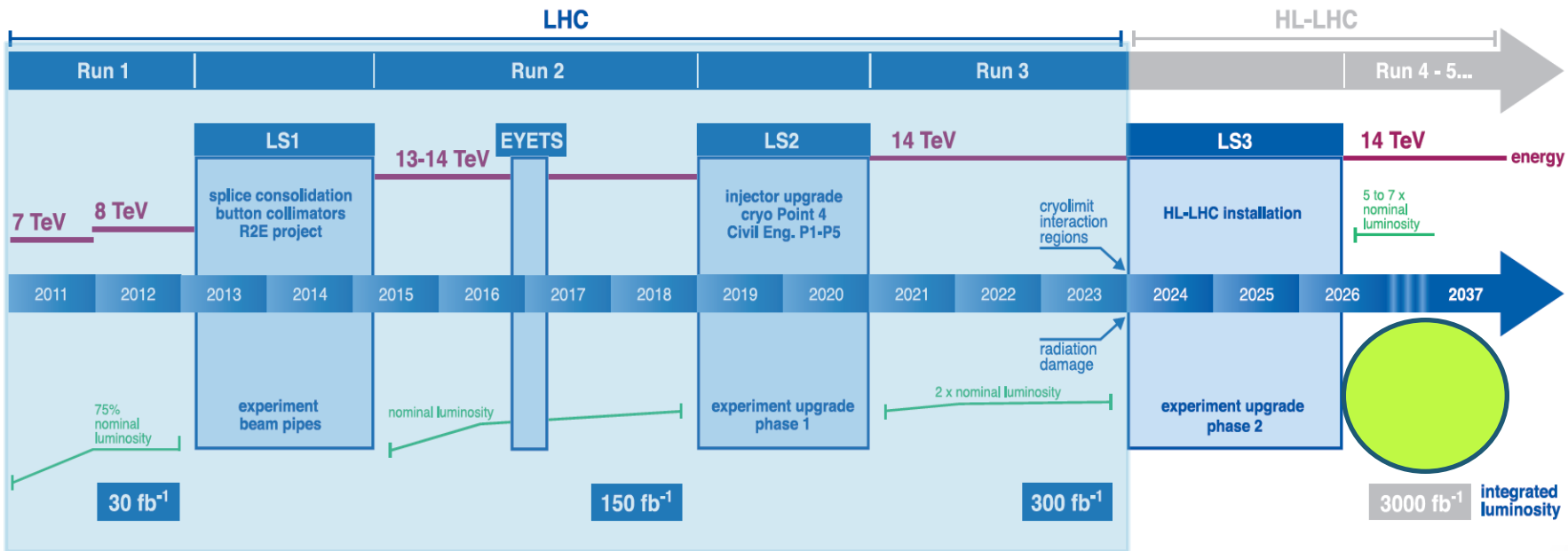

ATLAS UPGRADE



□ HL-LHC Main ATLAS Upgrades

- **New all silicon inner tracking detector ITK.**
- **New trigger L0/L1 system architecture**
- **New Calorimeter and muon system electronics**



The busy HL-LHC environment



The HL-LHC detector and trigger upgrades in phase II will have to deal with a very hostile environment while maintaining good performance and efficiency.



Run I - $\langle \mu \rangle \sim 25$

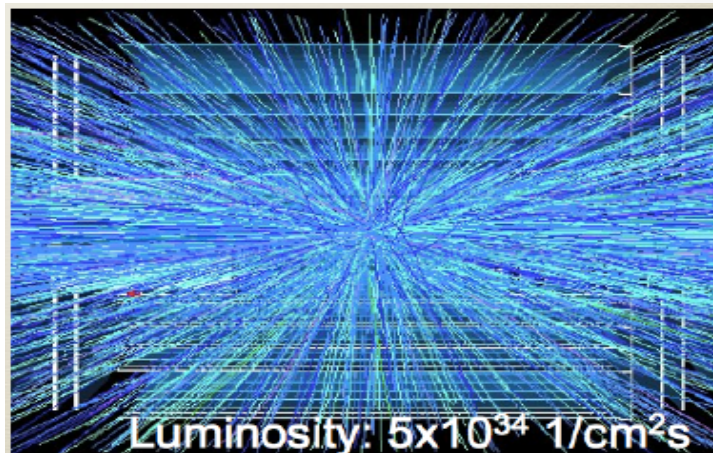
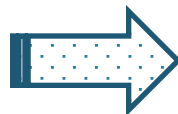

Run IV... $\langle \mu \rangle \sim 200$

- ❑ corrJVF variable used to discriminate between PU and HS jets.

- ❑ Good rejection against PU jets for area corrected HS jets, at High μ .

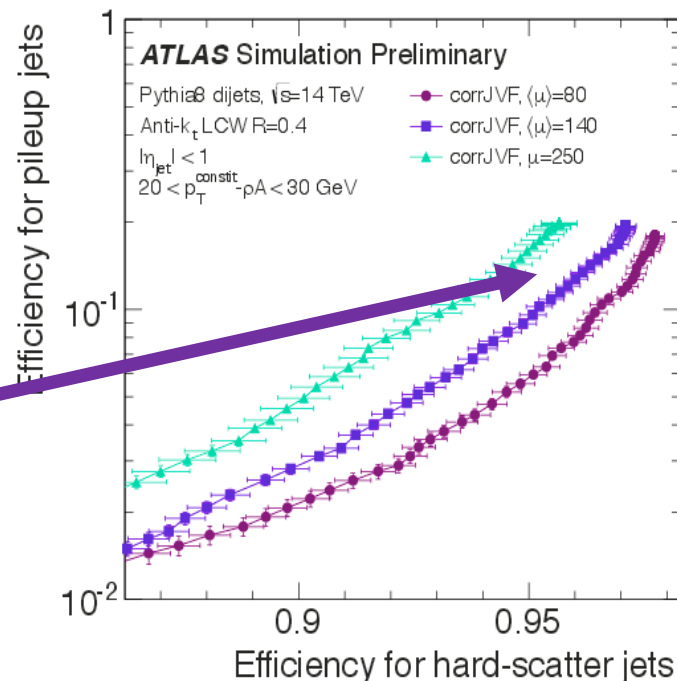
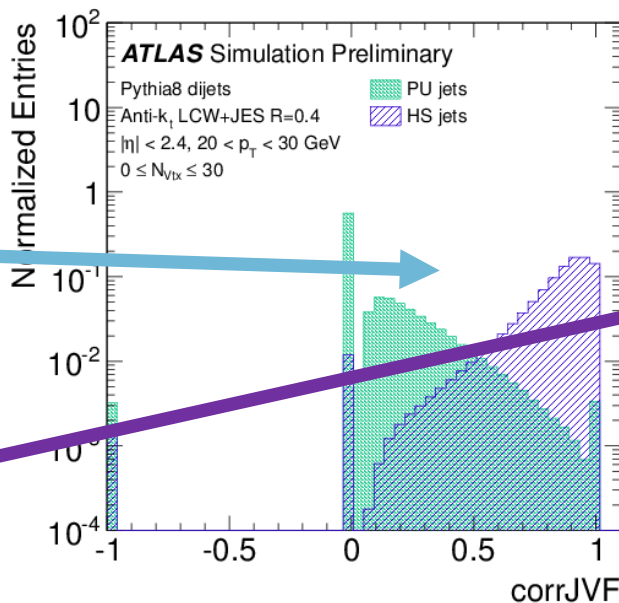



A fully new inner tracking detector (ITK)



- ❑ Current ID will be replaced by the ITK after Run 3.
- ❑ Fully silicon detector will be built extending significantly current pixel+SCT radial coverage in the radial and forward directions and the detector performance.
- ❑ A number of around 1000 tracks are expected per unit of rapidity, and an even larger track density is expected inside jets at the HL-LHC.
- ❑ B-tagging performance will be kept to good level using new multi-variate tagger, new techniques will be needed to recover Run 3 (or better) performance.

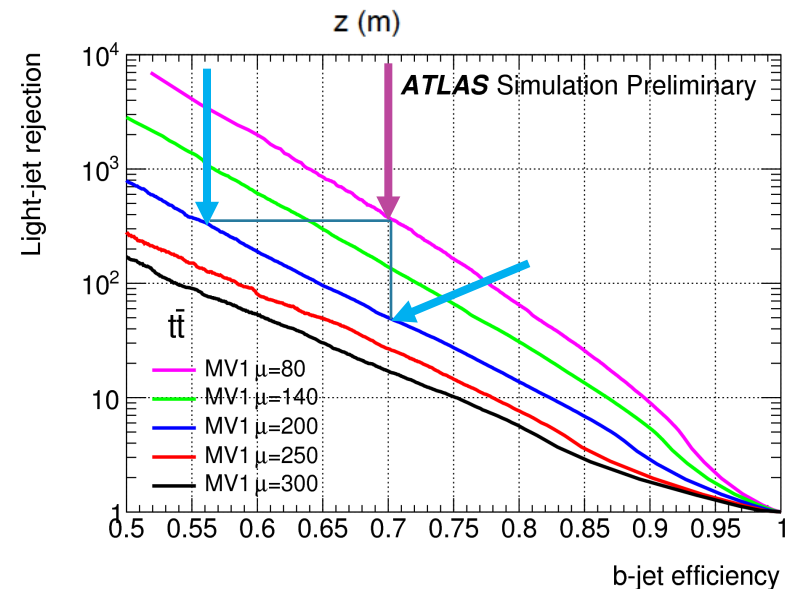
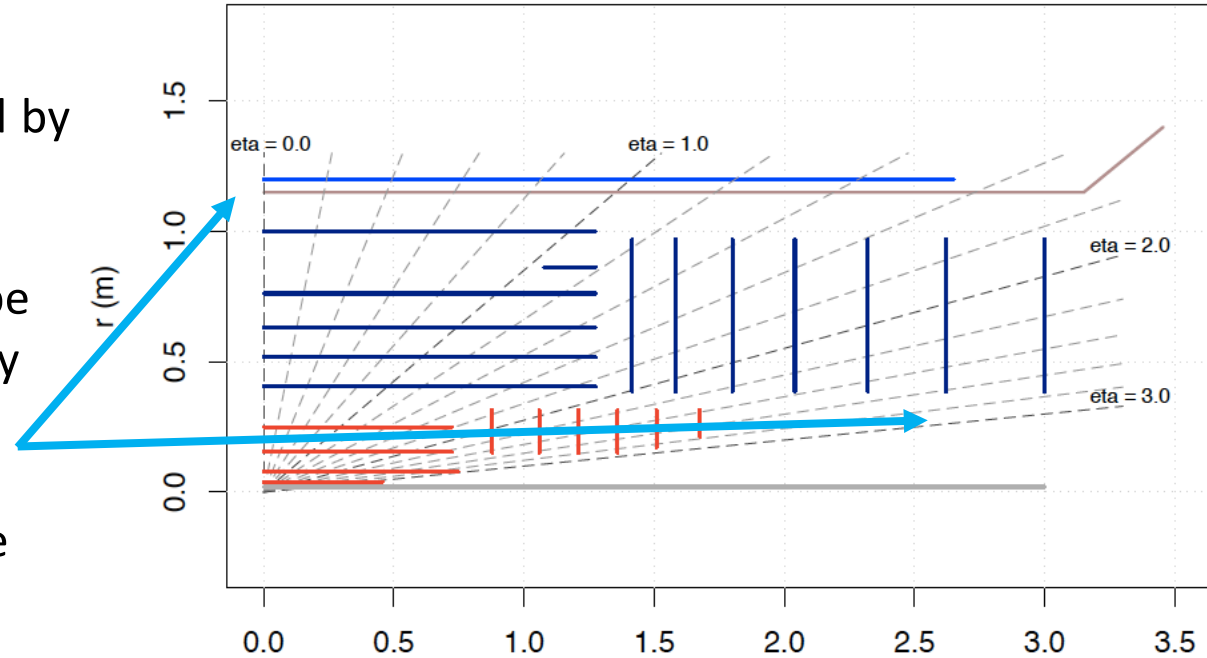



Split ATLAS hardware trigger system L0/L1 @ HL-LHC



❑ MDT detectors will be part of the L1-trigger at the HL-LHC

❑ Current L1 trigger rate and latency is constrained by the MDT read out, which would be difficult to access/change

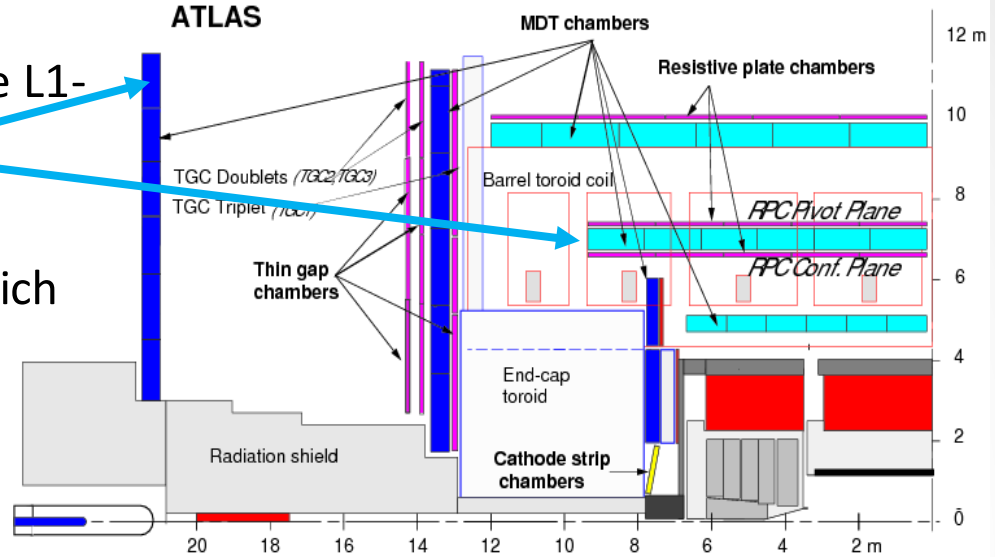

Detector	Max. Rate	Max. Latency
MDT	~ 200 kHz	~ 20 μ s
LAr	any	any
TileCal	> 300 kHz	any
ITK	> 200 kHz	< 500 μ s

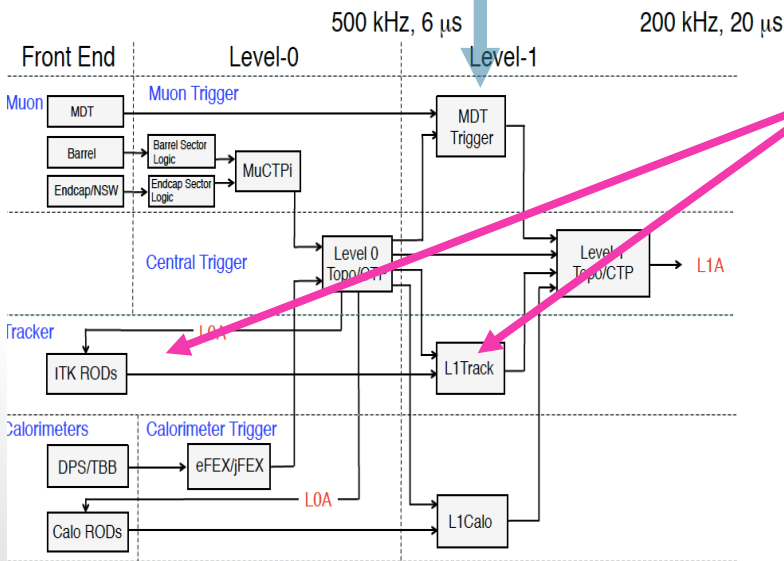

❑ L0/L1 Tracking will take information from the new ITK detector providing new triggering options at L1 and subsequent background/rate reductions, allowing a L1 output rate of 200 kHz after L0.

❑ This new trigger rates will demand the replacement of the calorimeters and muon system front and back-end electronics.



Summary



The ATLAS collaboration have developed an ambitious and detailed upgrade program for fulfilling the stringent luminosity conditions of the HL-LHC, while maintaining or improving the current detector performance.

☐ Run 2

- New innermost pixel layer (IBL).
- L1 topo-clustering.
- Detector consolidation.

☐ Run 3

- Improve of the L1 Trigger architecture, to cope with the high rate.
- Forward Tracking (FTK) Trigger
- NSW detector installation.

☐ HL-LHC

- New all silicon inner tracking detector.
- New trigger L0/L1 system architecture
- New Calorimeter and muon system electronics