

BIBLIOTHEQUE
C
28.10.69NPA/Int. 69-13
31 July, 1969

CERN

4700

THE HIGH-VOLTAGE CAPACITOR DISCHARGE SYSTEM
OF THE 200 kJ, 500 kA PULSED CURRENT SUPPLY FOR THE
MAGNETIC HORN AND REFLECTORS OF THE CERN NEUTRINO BEAM

G. Gruber, R. Gr^{ub} and B. Langeseth

SUMMARY

This report describes the capacitor discharge circuits of the new 500 kA, 200 kJ, 12 kV pulsed current excitation system of the magnetic horn and reflectors of the three-stage focusing system of the CERN neutrino beam, which is now being modified and adapted for an experiment with the Gargamelle bubble chamber. A brief general outline is given of the whole system, followed by a more complete description and specifications of the parameters, performance requirements, and essential technical details of the energy storage capacitor battery, the discharge switching assemblies, and the low-inductance pulse transmission cables and connectors.

CONTENTS

	Page
1. INTRODUCTION	1
1.1 General outline	1
1.2 Basic requirements	2
1.3 Selected method of solution	3
1.4 Operation experience with existing pulse systems	4
1.5 Prototype module for new pulse system	4
2. BASIC CIRCUIT OPERATION, PARAMETERS, AND SYSTEM LAYOUT	6
2.1 Circuit operation	6
2.2 System layout	7
2.2.1 The d.c. power supply	7
2.2.2 Energy storage capacitor battery	8
2.2.3 Discharge switching assembly	8
2.2.4 High-current pulse cables and connectors	8
2.2.5 Magnetic lens	9
2.2.6 Control electronics	9
3. ENERGY STORAGE CAPACITOR BATTERY	9
3.1 Voltage rating	10
3.2 Current rating	10
3.3 Mounting	13
4. DISCHARGE SWITCHING ASSEMBLY	13
4.1 The switching problem and available switching devices	13
4.1.1 Ignitron switches	15
4.1.2 Thyatron switches	15
4.1.3 Air spark-gap switches	16
4.1.4 Solid-state switches	16
4.2 Ignitron assembly	16
4.2.1 Ignitron switches	16
4.2.2 Trigger unit	17
4.2.3 Temperature control unit	20
4.3 Polarity reversal switches	20
4.3.1 Manual polarity reversal switches of the switching modules	20
4.3.2 Remotely controlled polarity reversal switch at the magnet	21
4.4 Crow-bar resistor	21
4.5 Auxiliary discharge circuit and safety switches	23
4.6 Measuring devices and ground connection	23
4.7 Cabinet layout	26

5. LOW-INDUCTANCE HIGH-VOLTAGE PULSE CABLES AND CONNECTORS	28
5.1 Cables	28
5.2 Connectors	31
REFERENCES	33
APPENDIX I: Data on the Existing Pulse Systems	35

List of Tables

	Page
Table 1.1 Parameters of the CERN neutrino beam pulse system	5
Table 3.1 Energy storage capacitor data	11
Table 4.1 Basic switching requirements	14
Table 4.2 Switching requirements for one of the 12 sections	17
Table 4.3 Ignitron trigger requirements	19
Table 4.4 Crow-bar resistor data	22
Table 4.5 Measuring facilities	24
1. Requirements	24
2. Proposed solution	24
Table 5.1 Pulse cable parameters corresponding to 2 parallel cables for each of the twelve parallel sections	30
Table A.I Components used in the existing equipment	35

List of Photographs

- 96-9-66 The 130 kJ capacitor discharge installation (consisting of 13 parallel branches).
- 46-6-67 Pulse cable connections to Reflector R2.
- 26-11-66 High-voltage switch.
- 195-5-69 Energy storage and discharge switching assembly module (closed model).
- 194-5-69 Energy storage and discharge switching assembly module (closed model).
- 299-5-69 High-voltage coaxial connector.
- 286-5-69 Trigger unit.

List of illustrations

Drawings:

- 224-244-0 : Neutrino beam installation layout
- 224-468-4A : Block diagram
- 224-133-3C : Discharge circuit diagram
- 224-480-4 : Currents and voltages in the discharge circuit
- 224-479-4 : Capacitor voltage as function of time
- 224-484-4 : Coaxial septum lens
- 224-443-3 : Tentative cabinet layout
- 224-325-3A : High-voltage switch
- 224-326-3A : Current transformer
- 224-457-2 : Auxiliary discharge resistor, carbon type
- 224-456-2 : Auxiliary discharge resistor, wire type
- 224-448-3 : Crow-bar resistor
- 224-449-3 : Crow-bar resistor details
- 224-455-3 : Polarity switch
- 224-458-2 : High-voltage coaxial connector
- 224-444-3 : Firing circuit
- 224-459-2 : Insulation plate
- 224-450-3 : Connexion
- 224-451-4 : Connexion
- 224-454-3 : Insulating piece
- 224-447-3 : Insulating piece
- 224-445-4 : Insulator
- 224-453-3 : Connexions
- 224-446-3 : Connexions
- 224-452-3 : Connexions

1. INTRODUCTION

1.1 General outline

The high-voltage capacitor discharge system described here is required to provide a high-current excitation of the magnetic field in the focusing devices of the new neutrino beam now being constructed for experiments with the 10 m³ Gargamelle heavy-liquid bubble chamber.

The beam is based on a three-stage focusing system¹⁻⁴⁾ (Drawing 224-244-0) with three coaxial septum lenses usually called magnetic horns⁵⁾ or reflectors, R1, R2, and R3⁶⁾. These magnetic lenses focus the neutrino parent particles (π and K mesons) produced in the target of an external proton beam operating with a 2 μ sec burst of 10^{12} protons of 25 GeV/c momentum at a regular repetition period of approx. 1.5 sec. The lenses have single-turn excitation conductors arranged as coaxial cylindrical structures up to 5 m in length and 2 m in diameter, and in the maximum field region the flux density reaches 10 Tesla at a peak current of 500 kA. The particles emitted from the target must traverse the inner current-carrying structure of the lenses, which therefore must be very light and transparent for particles in order to reduce absorption losses.

Since a constant magnetic field is required only for the 2 μ sec duration of each beam burst, a pulsed type of excitation system is sufficient; this is also necessary in order to limit the problems of stresses due to electromagnetic forces and heat dissipation, especially in the most critical region of the inner conductor of the lenses where a peak current density of the order of 10,000 A/mm² is required during each beam burst. The necessary current pulses are produced by discharging into the lens the energy stored in a high-voltage capacitor battery. The storage capacitors are recharged during the 1-2 sec intervals between beam pulses to an accurately preselected energy of up to 200 kJ at a voltage of maximum 12 kV. The charge is supplied by a controlled d.c. power supply.

Following a definition of the basic requirements and a brief outline of the adopted solution for the system, a more detailed description of the circuit is given in Section 2; the essential parameters, performance requirements and technical details of the energy storage capacitors, the discharge switching units, and the pulse transmission cables are specified in Sections 3, 4 and 5.

1.2 Basic requirements

The magnetic lenses are required to produce an intense magnetic field, and the necessary excitation current must remain at an essentially constant value of up to 500 kA during the 2 μ sec duration of each beam burst and be reproducible from pulse to pulse. The inductance and magnetic energy of a lens is typically 1.0 μ H, 125 kJ. In order to reduce particle absorption losses in the material of the magnetic lens structure, the cross-section -- especially of the inner conductor -- must be reduced to a strict minimum determined by the electromagnetic forces and the heat dissipated during each pulse.

Continuous d.c. excitation is therefore excluded, and a pulsed method is the only possible solution. Indeed it is of crucial importance to aim for a pulse of the shortest possible duration that is practically achievable by economically acceptable means.

Reliable continuous functioning without interruption during each beam operation period is of essential importance in order to use the Proton Synchrotron beam with maximum efficiency for bubble chamber exposures during the time the beam is allocated for the experiment. Not only is beam operation cost per hour very high, but more significantly the amount of beam operation time allocated to each research project is strictly limited, and an occasion lost due to equipment failure cannot be easily compensated for but may be lost for ever. Reliable operation without maintenance is therefore required for durations of several million pulses. According to experience, this is perfectly achievable by safe design and an adequate standard of execution for all parts throughout the entire system, with the following exceptions :

- The inner conductor of the lenses, especially R1, should be critically dimensioned and may therefore need replacing due to fatigue failure from time to time.
- The reliable operation life limit of available discharge switches is not reproducible but is spread over a wide range with an average value of less than 10^6 pulses.
- Radiation damage of the high-voltage cable insulation and other sensitive items located in the target region is expected after an

integrated beam current in the range 10^{18} - 10^{19} protons has been reached at the target. Assuming 10^{12} protons/pulse, operation difficulties due to radiation effects may therefore be expected to become a problem after an operation period in the range 10^6 - 10^7 pulses; the exact limit depends on many factors and cannot be easily assessed.

1.3 Selected method of solution

A capacitor discharge system has been chosen as the most suitable solution. By this method, a sinusoidal current pulse with a base time of approximately 100 times the desired constant field duration (2 μ sec) can be achieved using mainly commercially available components, except for certain critical items.

Several different pulse circuit configurations and their various particular features have been considered.

In the simplest capacitor discharge circuit the magnet is switched to the capacitor in series with a damping resistor in which most of the energy is dissipated. In an oscillatory circuit with little damping, the current reversal is harmful to the main discharge switch and the voltage oscillations are harmful to the capacitor and cable insulation, and expensive components must be used. With a critically damped or over-damped circuit these problems are avoided, but in this case the energy transfer efficiency is very low since most of the energy is lost in the bigger damping resistor, and a correspondingly bigger energy storage is required. The compromise of a moderately damped oscillatory circuit is a practical solution when simplicity and inherently safe operation is important. This solution was actually selected for the first magnetic horn system⁷⁾.

The high efficiency of the oscillatory circuit is maintained and the unwanted features avoided by introducing a crow-bar circuit which produces a short circuit in series with a damping resistor just after the first quarter oscillation period. Such a system is more complex and involves the problem of achieving reliable functioning of the crow-bar switch. This circuit was chosen for the present case as well as for the two similar existing systems made for reflectors R2 and R3 because of the high-energy transfer efficiency, and it also facilitated a very economical solution for the energy storage capacitors.

1.4 Operation experience with existing pulse systems

Certain experience in design, construction, and operation of high-current pulse systems is already available at CERN, and the new system will largely be based on this experience.

The first magnetic horn pulse system was constructed already in 1962-1963, and is described in Refs. 5 and 7. This system had a very low energy transfer efficiency, and only about 40 kJ (25%) was transferred to the magnet, since most of the total 150 kJ energy stored in the capacitor was absorbed in the 90 m Ω damping resistors included for safety reasons in series with each of the eight parallel capacitor sections. It operated for several million pulses mostly in the range 200-300 kA at a repetition period of 2-3 sec during the 1963-1964 neutrino experiment. Performance reliability was limited by frequent uncontrolled premature firing ("prefiring") of the main ignitron discharge switches. A certain fraction of the pulse cables and connectors also failed. Following repeated breakdowns and because of increased output energy requirements, this system must now be renewed.

Two bigger pulse systems with improved transfer efficiency were constructed^{8,9)} and operated for about 2×10^6 pulses for the 1966-1967 neutrino experiment, and for various development tests on new magnetic horn devices mostly in the range 300-400 kA at a 2.0 sec pulse repetition rate (Photo 96-9-66 and 46-6-67). Frequent voltage breakdown (prefiring) of the main ignitron discharge switches limited the performance reliability and made it difficult to operate the two systems at full voltage (12 kV). Increasing firing delay with age of the crow-bar ignitrons also caused a certain amount of interruption of operation in order to replace defective ignitron units.

The parameters of the R1, R2, and R3 pulse systems are listed in Table 1.1.

1.5 Prototype module for new pulse system

The concept for the new pulse system is based on the experience gained with the existing R2 and R3 systems. The new system will be constructed with 12 energy storage capacitor and discharge switching modules.

Table 1.1

Parameters of the CERN neutrino beam pulse systems

	Old Horn system	New R1 system	Existing R2 system	Existing R3 system
Peak pulse current total (kA)	300	500	500	500
per section, nominal (kA)	38	42	42	42
per section, max. (kA)	-	50	50	50
Stored energy $\frac{1}{2} CV^2$ (kJ)	150	200	200	120 (initial) 200 (extended)
Energy transferred to magnet $\frac{1}{2} L I^2$, approx. (kJ)	45 at 300 kA	-	106 at 400 kA	56 at 400 kA
Transfer efficiency $(\frac{1}{2} L I^2)/(\frac{1}{2} CV^2)$, approx. (%)	30	-	70	60
Charging voltage, max. (kV)	11.6	12.0	12.0	12.0
Capacitor voltage reversal (%)	30	25	25	25
No. of parallel circuit sections	8	12	12 (+1 reserve)	12 (+1 reserve)
Inductance of magnetic lens (horn or reflector) (μH)	≤ 1.0	0.5-1.5	1.3	0.7
Total circuit inductance (μH)	1.1	1.0-2.0	1.6	1.0
Current rise-time $\frac{1}{2} (LC)^{\frac{1}{2}}$ (μsec)	80	80-120	80	50
Capacitance				
total (μF)	2227	2780	2780	1710 (initial) 2780 (extended)
per section (μF)	278	235	235	143 (initial) 235 (extended)
Electric charge in capacitor bank				
total (Asec)	25.8	33.3	33.3	20.5 (initial) 33.3 (extended)
per section (Asec)	3.2	2.8	2.8	1.7 (initial) 2.8 (extended)

The new modules should be basically similar and electrically identical to the old type, but the general execution, the safety aspects, monitoring facilities and the construction of many practical details must be brought to a higher standard.

A model of the improved version has therefore been constructed as a tentative prototype module for the new system. The new module is self-contained and completely enclosed in an independent closed metal cabinet (Photo 194-5-69 and 195-5-69). This construction should reduce the acoustical and electrical noise level, and permit an over-all simplified arrangement of the installation as compared to the old modules, which were assembled in open frames and enclosed together in a common high-voltage safety cage with interlocked doors preventing access while the circuit was under tension.

The cabinet of the prototype module (Photo 194-5-69) is divided into two compartments. The energy storage capacitors are accommodated in the rear compartment, and the discharge switching assembly is located in the front compartment, which has a transparent window intended mainly for visual inspection of the discharge switches. Further details are described more completely in Sections 3 and 4.

2. BASIC CIRCUIT OPERATION, PARAMETERS, AND SYSTEM LAYOUT

The basic schematic diagram of the 500 kA pulse system is shown in Drawing 224-133-3. The high-current capacitor discharge circuit has been divided into twelve branches or sections in order to reduce the switching problem down to the range attainable by practical switching devices.

2.1 Circuit operation

The various voltages and currents in the capacitor discharge circuit as function of time are represented in Drawing 224-480-4.

A precision-controlled d.c. power supply charges the twelve energy-storage capacitor sections to an adjustable preselected voltage of max. 12 kV during the approximately 1.5 sec intervals between beam bursts. At a programmed instant about 100 μ sec (exactly $\frac{1}{4}$ oscillation period) before each beam burst, all sections are switched simultaneously to the low-inductance magnetic lens by means of individual discharge switches and coaxial transmission cables. A sinusoidal current pulse starts to flow

through the magnet and reaches a maximum after about 100 μ sec, while the capacitor voltage falls cosinusoidally to zero and then reverses to negative values. The voltage reversal will normally be limited to 3 kV (or 25% of max. charging voltage) by means of the parallel crow-bar circuits, which start conducting soon after the capacitor voltage has reversed polarity. Consequently, the oscillation stops, and the magnet current and the crow-bar voltage decrease exponentially with a time-constant of approximately 150 μ sec determined mainly by the lens inductance and the resistance of the crow-bar circuits. At the same time, the capacitor voltage decreases with a time characteristic determined by the parameters of the HV charging circuit, except in the case of back-firing of the main discharge switch.

Occasionally the crow-bar switches of one or more sections may fire with a delay, or may fail to fire completely. The total current is then shared by the reduced number of remaining circuit branches, each of which must therefore carry a higher current above the normal value. This results in an increased voltage drop across the crow-bar resistors, and therefore in an abnormally high reverse voltage on the capacitors. In the extreme case when all crow-bar switches fail, the capacitor voltage may reach a reverse value of up to 85% of the original charging voltage since the oscillations continue at a frequency of around 2.5 kHz and are attenuated only by the natural circuit resistance. In the more common case, rarely more than a few crow-bar switches fail for the same discharge pulse, and the reverse capacitor voltage then exceeds the normal value only moderately.

2.2 System layout

The pulse system is built up of functional assemblies and modules, as represented in the block diagram Drawing 224-468-4. The basic functions and features of the main constructional units are listed below:

2.2.1 The d.c. power supply

The d.c. power supply charges the energy storage capacitor battery to a preselected voltage adjustable in the range 0-12 kV during the interval of 1-2 sec between discharge pulses. The charging current is adjustable in the range 0-35 A. Accurate current and voltage stability are achieved by means of a thyristor controller on the primary side of the HV transformer. The twelve outgoing charging circuit branches are fully

protected against all normally occurring faults in the high current discharge circuit. Complete details are described in Ref. 10.

2.2.2 Energy storage capacitor battery

The capacitor battery is built up of 12 modular sections usually in the range of 10-20 kJ (140-280 μF) each at 12 kV. Each modular section is made up of several smaller units of 2-3 kJ per container. Further details are described in Section 3.

2.2.3 Discharge switching assembly

Each discharge switching assembly is rated for 50 kA, 20 kJ (280 μF) at 12 kV, 1.0 pulse/sec max., and includes the following constructional parts:

- Main discharge ignitron switch with isolation transformer for the trigger pulse circuit.
- Crow-bar circuit with a low-inductance water-cooled crow-bar resistor in series with the crow-bar ignitron switch provided with a self-ignition circuit.
- Toroidal current transformers for providing the necessary signals for current monitoring and interlock circuits.
- Auxiliary discharge circuit with an auxiliary discharge contactor operated by the interlock circuits and connected in series with a dumping resistor into which the stored energy is discharged when the system is stopped manually or, in cases of faults, by the protection interlock system.
- Manual safety switch for shorting and grounding both capacitor terminals.
- Polarity reversal switch for changing the direction of the current through the load.

Further details are described in Section 4.

2.2.4 High-current pulse cables and connectors

Two low-inductance coaxial cables in parallel with a resulting inductance of 25 nH/m connect each energy storage section to the magnetic lens, which is located at a distance of 50-100 m from the supply equipment. Further details are described in Section 5.

2.2.5 Magnetic lens

The magnet is a low-inductance single-turn air-core coaxial septum lens (magnetic horn or reflector, Drawing 224-484-4) with an inductance in the range 0.5-1.5 μH and a resistance of negligible value. The lenses and their beam optical applications are described in Refs. 1 to 6.

2.2.6 Control electronics

The electronic control instrumentation is divided into the following groups: The local and remote units with the interlocks, the timing system, and the signal measurement and display unit. The remote control unit contains extensions of the most important controls and indication lamps on the local control unit, and in addition a delay control for adjusting the timing of the discharge current pulse.

The timing system receives a synchronizing pulse train, from which it derives timing pulses for the charging supply, the interlocks, the current measuring unit and, via the local control unit, for the ignitron trigger unit.

The interlocks are an important part of the local control unit, ensuring continuous automatic protection of the system. They will switch off or prohibit switching on in case of danger to personnel or equipment, and a set of lamps indicates the nature of the failure.

The signal measurement and display unit gives a digital display of the peak current in the magnetic lens, and provides an oscilloscope for displaying the current waveforms. Complete details are described elsewhere¹¹⁾.

The energy storage capacitor battery, the discharge switching assembly, the high-current pulse cable, and the connectors are described in full detail in the following sections. The d.c. power supply, the magnetic lens, and the control electronics are described separately in the references quoted above.

3. ENERGY STORAGE CAPACITOR BATTERY

Each of the twelve energy storage capacitor sections is designed for a maximum energy of 20 kJ at 12 kV. Each section is composed of several smaller units (containers) mounted in the rear compartment of the modular assembly cabinet (Photo 194-5-69). An energy of 2-3 kJ per capacitor

container has been assumed since this corresponds roughly to the heaviest weight and largest size that can conveniently be handled in case replacements should be required in the upper parts of the cabinets.

The most essential capacitor data are specified in Table 3.1, and further explanations are given below.

3.1 Voltage rating

The working voltage is 12 kV. It may be assumed that the capacitor will normally be charged at roughly constant rate during the first 3/4 of each repetition interval, and that it remains at the final voltage for the last 200-300 msec before each discharge. However, to allow for triggering failure and for manual timing it is desired that the capacitor can withstand full voltage for longer periods of duration, to be proposed by the supplier. Exceptionally the capacitor voltage may reach 13 kV in case of faulty operation of the voltage control circuits of the d.c. power supply.

The voltage reversal on the capacitor is normally limited to 3 kV by the crow-bar circuit, which fires just after the capacitor voltage starts reversing after $\frac{1}{4}$ period. The reliability of the crow-bar circuit may be assumed to be 99.9%, and in case of failure the voltage reversal will reach 80-85 %.

3.2 Current rating

The energy and the current rating of each storage section depend largely on the rating of readily available discharge switching ignitrons, and a peak current value of 50 kA/20 kJ at a repetition rate of 1 pulse per second should be assumed as normal operation. The period of the damped oscillatory discharge will normally be in the range 200-400 μ sec, but the oscillation is stopped by firing the crow-bar ignitron shortly after $\frac{1}{4}$ period. (See Section 2.) A peak fault current of 150 kA/20 kJ should be considered.

All internal and external connections and the cooling must be sufficient for these conditions. Furthermore, the design must be such that when the total energy of a section is discharged into a local fault in one of the capacitor containers, no catastrophic effects result, and there is no damage to the other containers of the section. The charging circuits of different sections are separated by diodes or other means, such that harmful

Table 3.1

Energy storage capacitor data

1. Voltage ratings

1.1	Charging voltage, normal operation	:	12 kV
	fault condition	:	13 kV
1.2	Voltage reversal on capacitor, normal operation	:	3 kV
	fault condition	:	85%
1.3	Duration of voltage application between discharge pulses	:	1.0-2.0 sec
1.4	d.c. test voltage applied during 60 seconds	:	To be specified
1.5	d.c. test voltage applied during 1.0 hour	:	To be specified

2. Discharge current ratings

2.1	Repetition peak current	:	2.5 kA/kJ
2.2	Current pulse duration	:	30-300 μ sec
2.3	Pulse repetition frequency	:	1 pulse per second - 1 pulse per 2 sec
2.4	Cooling	:	Natural air at 20 \pm 20°C
2.5	Fault current	:	Limited only by internal inductance and resistance
2.6	Current test	:	20 discharges with short terminals

3. Life

3.1	Expected life	:	To be quoted by manufacturer
3.2	Guaranteed life, allowing 10% failure	:	5 million discharges or 1 year, whichever is shorter

Table 3.1 (cont.)

Energy storage capacitor data

4. Execution

- | | | | |
|-----|--|---|---|
| 4.1 | Weight per container | : | Max. 100 kg, preferably 50-75 kg, exact value to be specified by manufacturer |
| 4.2 | Capacitance and energy per container | : | Preferably about 40 μ F, 3.0 kJ |
| 4.3 | Capacitance tolerance | : | To be agreed |
| 4.4 | Inductance and self-resonance frequency | : | To be agreed |
| 4.5 | Terminals | : | Both poles insulated from casing |
| 4.6 | Dimensions and mounting | : | To be specified by manufacturer |
| 4.7 | Energy density in Joules per litre of volume (terminals, brackets, etc., not included) | : | To be specified by manufacturer |
| 4.8 | Insulating material, thickness, and number of layers | : | To be specified by manufacturer |
| 4.9 | Impregnation material | : | To be specified by manufacturer |

currents cannot flow from one section to another via the charging circuit.

Energy absorbing resistors or fuses in series with each capacitor element to limit the effects of a local fault are not desired.

3.3 Mounting

The containers of each section are mounted in the rear compartment of the cabinet designed for indoor installation in still air of a temperature between 0°C and +40°C.

Forced air-cooling is undesirable, but if necessary a fan could be foreseen for each cabinet.

The terminals should be arranged to facilitate low-inductance parallel connections between the various containers of each storage section with closely spaced parallel busbars. Both terminals must be insulated from the case.

4. DISCHARGE SWITCHING ASSEMBLY

4.1 The switching problem and available switching devices

The HV switching problem is basically to switch a stored energy of 200 kJ at 12 kV to produce a current pulse of max. 500 kA through the magnet, and to crow-bar this current at the first current maximum of the oscillation. This operation is repeated for millions of pulses at a regular repetition period adjustable in the range of 1.0-2.0 sec. The basic switching requirements are listed in more detail in Table 4.1, which is based on the circuit shown in Drawing 224-133-3, and on the voltage and current pulse forms illustrated in Drawings 224-480-4 and 244-479-4.

The main discharge switch is under voltage nearly continuously, but must hold off the full 12 kV only for the last 100 msec of each charging period.

The crow-bar switch should switch, at close to zero voltage, a crow-bar current rising from zero to 500 kA in 10 μ sec.

Since no single switch will meet the specification, the total current is split into the number of branch currents that is suitable for the practical switching devices actually available, and several types of switches have been considered including

Table 4.1

Basic switching requirements

1. Main switch

Forward voltage	12 kV
Duration of application	1.3 sec
Reverse voltage	3 kV
Duration of application	200 msec
Pulse duration ($\frac{1}{4}$ sine-wave)	100 μ sec
Repetition period	1.5 sec
Peak current	500 kA
r.m.s. current	2.3 kA
Initial rate of rise of current	10 kA/ μ sec
i^2t -integral	12×10^6 A ² sec
Charge transported	33 Asec

2. Crow-bar switch

Forward voltage	3000 V
Duration of application	5 μ sec
Reverse voltage	12 kV
Duration of application	100 μ sec
Pulse duration (exponential decay, 10% value)	350 μ sec
Repetition period	1.5 sec
Peak current	500 kA
r.m.s. current	3.5 kA
Initial rate of rise of current	50 kA/ μ sec
i^2t -integral	20×10^6 A ² sec
Charge transported	75 Asec

- a) ignitrons
- b) thyratrons
- c) air spark-gaps
- d) solid-state switches (thyristors, silicon diodes).

4.1.1 Ignitron switches

Ignitrons of various makes are used in the existing systems. They have the advantage of being very rugged and able to withstand very high overcurrents under fault conditions inherent to them, without suffering permanent damage. One of these faults is premature firing of a single ignitron, which results in a current up to twice the nominal peak value in the particular branch. The ignitron life is on the average about 10^6 pulses for exceptionally good samples. The performance from sample to sample is not reproducible and spreads over a wide range from a few pulses up to well above 10^6 pulses. Ignitrons have the disadvantage that they require anode heating and careful temperature control of the cathode (and walls) by means of a water circuit.

At present, preference is being given to ignitrons over the other types of switches, because 12 of them in parallel can cope with the switching load defined in Table 4.1. The cost of the battery of devices required seems to be less than for the alternative solutions.

4.1.2 Thyratron switches

Thyratrons are available for a very wide range of applications up to moderate pulse current ratings. They have the particular feature that they can be triggered with very small delay and jitter, of the order of nanoseconds. Relatively little information has been available about the durability and general performance of thyratrons for the type of heavy current pulse application considered here.

Although these devices are used extensively and may be suitable for very short high-voltage pulses, we have no indication that thyratrons could provide an economically competitive solution to the present switching problem. Since they also do not seem to be as robust as ignitrons, the use of thyratrons does not seem to be a practical proposition.

4.1.3 Air spark-gap switches

Triggered spark-gap switches operating in air at various pressures are used for certain high-voltage high-current fast-switching applications. These devices can be made with particular features, including short trigger delay, small trigger jitter, and very fast current rise-time. For a moderate charge of 10^{-2} Asec/pulse, an operation life of 10^7 pulses has been achieved¹²⁾, corresponding to an integrated charge transfer of 10^5 Asec. Tests on spark gaps for very high currents have shown that only a very small amount of electrode erosion, with no effect on performance, was caused by a charge transfer integral of 2.5×10^5 Asec at 250 kA, 50 Asec per pulse¹³⁾.

Spark-gap switches suitable for our purpose are at present not commercially available, and due to limitation of our available effort a more complete consideration of the possibility of a solution with spark gaps has been postponed.

4.1.4 Solid-state switches

Blocking voltage and current-carrying capability of commercial thyristors and silicon diodes are steadily increasing, and they have also been considered as a possible alternative. Their definite advantage is reliability and long operation life if properly used. But at present more than 300 of these devices would be needed in a series and parallel arrangement¹⁴⁾ -- a solution that does not seem to be economical.

This number of elements could be considerably reduced by introducing di/dt limiting saturating series reactors that would be of sufficient size to prevent high current until a large enough junction area has been ionized¹⁵⁾.

The possibility of using solid-state switching devices for the present type of application seems technically feasible, but the cost and testing effort required to check in certain points reliably would be beyond our possibilities for the present project.

4.2 Ignitron assembly

4.2.1 Ignitron switches

Although in past experiments the ignitron switches, as described

Table 4.2

Switching requirements for one of the 12 sections

1. Main ignitron

Forward voltage	1-12 kV
Duration of application	0.8-1.8 sec
Reverse voltage	0-3 kV
Duration of application	200 msec
Pulse duration ($\frac{1}{2}$ sine wave)	80-120 μ sec
Repetition period	1.0-2.0 sec
Peak current, max. with 12 branches	42 kA
" " max. with 10 branches	50 kA
" " under fault condition, max.	150 kA
r.m.s. current, max.	300 A
Initial rate of rise of current, max.	1 kA/ μ sec
i^2t -integral, max.	10^5 A ² sec
Charge transported, max.	3 Asec

2. Crow-bar ignitron

Forward voltage	300-3000 V
Duration of application	5-20 μ sec
Reverse voltage	1-12 kV
Duration of application	80-120 μ sec
Pulse duration (exponential decay, 10% value)	300-500 μ sec
Repetition period	1.0-2.0 sec
Peak current, max. with 12 branches	42 kA
" " max. with 10 branches	50 kA
" " under fault condition, max.	150 kA
r.m.s. current, max.	400 A
Rate of rise of current, max.	4 kA/ μ sec
i^2t -integral, max	1.5×10^5 A ² sec
Charge transported, max.	8 Asec

earlier, have not met the requirements, there is no indication that other switching devices will give a better performance without time- and money-consuming development work. Therefore it is proposed to use ignitrons both as main and crow-bar switches for the new R1 system. Therefore, this system is divided into 12 parallel units as the R2 and R3 discharge switching assemblies.

The nominal peak current rating of the system is 500 kA. When equally shared among 12 parallel branches, this would correspond to 42 kA/branch. However, each branch should be rated for 50 kA in order to allow for uneven current-sharing and to permit operation at full current with one or two branches missing.

The switching requirements per branch are collected in Table 4.2.

4.2.2 Trigger unit

The most important ignitron trigger requirements are compiled in Table 4.3. The data in this table are very general and not matched to any specific make or model on the market.

An example of the firing circuit used in the existing systems to transform the external timing pulse into the more powerful pulses required to fire the main discharge ignitrons is shown in Drawing 224-444-3. The circuit is assembled in a standard 19" chassis unit (Photo 286-5-69).

The circuit must be capable of operating from the input pulse shown in the diagram, and provide the required output pulse at a maximum repetition rate of 1 pulse per second.

The circuit operation is as follows: A positive pulse of 1 ± 0.3 μ sec duration is applied to the transformer T1. The positive pulse from the secondary winding of T1 is applied to the gate of thyristor SCR1 via diode D1; SCR1 discharges capacitor C1 via transformer T2. The positive output pulse from the secondary winding of T2 is applied to the ignitor of ignitron V1. This ignitron discharges the capacitors in the 12 parallel circuits via their respective transformers. The output pulses from the transformers are fed to the ignitors of the main ignitrons. Precaution is taken, by means of a diode between ignitor and cathode, to ensure that the ignitor never reaches a negative potential in excess of 5.0 V with respect to the cathode.

Table 4.3

Ignitron trigger requirements

Type of trigger circuit	separate excitation
Type of trigger switch	ignitron
Trigger capacitor	0.25-1.0 μ F
Charging voltage	1.5-3.0 kV
Current limiting resistor	2-10 Ω
Trigger loop inductance (including transformer leakage inductance)	1.0-20 μ H
Trigger current, peak	50-200 A
Trigger pulse duration	5-50 μ sec
Rate of rise of trigger current	0.1-1.0 kA/ μ sec
Maximum firing jitter	\pm 1.0 μ sec
Negative voltage between ignitor and ignitron cathode	0-5 V

At the present time it might be possible to replace ignitron V1 by a high-voltage thyristor and to modify the trigger circuit accordingly.

4.2.3 Temperature control unit

Since the ignitrons have to be operated at a constant temperature around 40°C, they are connected to a closed-loop distilled-water circuit. It consists of a water reservoir, a heater, a heat exchanger cooled by the normal water supply in the building, a temperature sensor, a transfer pump, the temperature control electronics, and some indication lamps. All wet parts in this circuit are non-ferrous or made of stainless steel. The temperature control electronics switches the cooling water in the heat exchanger or the current in the heaters on or off in such a way that the predetermined temperature is maintained to within $\pm 2^\circ\text{C}$. The working temperature can be selected anywhere between 20°C and 80°C. If the temperature excursion exceeds the specified limit, the interlock chain should be activated to switch the whole system off.

The high-pressure side of the transfer pump is connected to the ignitrons and, via a throttle valve, to a bypass circuit. The water pressure in and the flow through the ignitrons can be adjusted by means of the throttle valve. The bypassed water flow serves to cool the pump and to stir the water in the reservoir in cases of reduced water flow requirements.

4.3 Polarity reversal switches

4.3.1 Manual polarity reversal switches of the switching modules

From time to time it is necessary to reverse the magnet current and magnetic field direction in the lens in order to focus particles of the opposite sign (for producing a beam of neutrinos and anti-neutrinos, respectively). Polarity changing facilities have therefore been included at the outgoing terminals of each switching module. These switches (Drawing 224-455-3) consist essentially of two pairs of partially overlapping plates which are connected to the outgoing cables and the switching module, respectively. By means of four heavy bolts passing through two isolating and two electrically conducting tubular spacers, one can connect each plate of one pair to each plate of the other pair. Proper insulation between all of these plates is required in order to avoid spark-over and surface discharges. The construction must be very rigid because of the magnetic forces involved.

This arrangement has the disadvantage that the cables must be operated with the full voltage on the outer conductor against ground for one of the two polarities and for approximately half of the operation time. The insulation of the outer cable conductor against earth must therefore be made for 12 kV.

4.3.2 Remotely controlled polarity reversal switch at the magnet

In order to avoid high voltage on the outer cable conductor, an alternative solution with a polarity reversal switch located at the magnet end of the cables would be desirable. Since this switch would be located in the radiation area, it should preferably be remotely controlled, or at least be such that any manual change-over operation could be made quickly. A satisfactory solution has not yet been found, but it is hoped to install such switches at a later stage.

4.4 Crow-bar resistor

The crow-bar resistor (see Table 4.4) is a low-inductance heavy-duty resistor, and represents most of the R in the RL circuit after the crow-bar ignitron has fired. The resistance value of 60 m Ω has been chosen so that the negative voltage overswing does not exceed 3 kV and the time constant for the current decay is $L/R = 150 \mu\text{sec}$, which is sufficiently short to limit satisfactorily the heat dissipation in the magnet and other circuit components. Typical values for voltage and current are shown in Drawing 224-480-4.

Occasionally it may occur that the crow-bar ignitron breaks through immediately after the main ignitron has fired. In this case a very short current pulse of 150 kA peak flows through the crow-bar circuit. Although this happens very rarely and the protection circuit switches off immediately after such a failure, the crow-bar resistor must withstand the electrical and mechanical stresses.

The crow-bar resistor must have a very low inductance in order to achieve a sufficiently short rise-time of the crow-bar current. Short rise-time is needed to limit the negative voltage overswing. In order to achieve low inductance, the crow-bar resistor is made of a stainless-steel foil, which is folded together and insulated by mylar sheets. Water-cooled copper plates between the mylar insulation remove the energy dissipated (Drawing 224-448-3).

Table 4.4

Crow-bar resistor data

Essential requirements:

Resistance	:	60 m \pm 3%
Inductance	:	45 nH \pm 10%
Peak pulse current, normal operation with 12 sections	:	42 kA
normal operation with 10 sections	:	50 kA
fault condition	:	150 kA
Heat dissipation per pulse	:	15 kJ
Heat dissipation, average	:	10 kW
Pulse voltage	:	12 kV

Construction data of actual components used in the existing equipment

Conductor	:	stainless steel 0.30 mm \times 228 mm = 68.4 mm ²
Current density at 50 kA	:	730 A/mm ²
Cooling water flow at P = 3 kp/cm ² , per circuit	:	1.5 l/min
total for 4 parallel circuits	:	6 l/min
Max. water pressure, at inlet	:	6 kp/cm ²
at outlet	:	3 kp/cm ²
External dimensions	:	1160 \times 380 \times 150 mm
Weight	:	59 kg

The ends of the stainless-steel foil are both covered with an electrolytically deposited copper layer of about 0.4 mm thickness over a length of 80 mm and are soldered to the electrical connections. The sides of the crow-bar resistor are covered with SRBF plates, and are clamped together by means of aluminium U-profiles and bolts. Further details are shown in Drawing 224-449-3.

The cooling water circuits are connected in parallel by means of a small manifold mounted at one of the U-profiles.

4.5 Auxiliary discharge circuit and safety switches

A high-voltage dump switch is provided to discharge the capacitor into a dump resistor of approximately 1 k Ω (Drawing 224-325-3A and Photo 26-11-68). It is used when the system is switched off manually or by the interlock circuit in case of certain fault conditions. This switch is closed by gravity forces and/or a spring-load, and is opened by a 24 V d.c. solenoid. Sufficient damping prevents bouncing of the tungsten contacts, which should be tested to withstand many years of normal operation (about 10,000 discharges). The dump switch is fitted with a microswitch (working contact to indicate when the switch is open) for the interlock chain. The power capability of the dumping resistor allows dumping of the maximum energy stored in the unit 10 times in 10 seconds every 20 minutes (Drawing 224-457-2 and Drawing 224-456-2).

A safety switch is provided which is operated manually from outside the cabinet. It is not to be used for discharging the capacitors but to ensure that both capacitor terminals are at earth potential and that charge accumulation is impossible. Therefore a d.c. current rating of 300 A \pm 100 A is sufficient. There is no danger in the fact that this switch will disintegrate if, due to a coincidence of faults, it is closed when the capacitors are charged. Since no unknown transient voltages can appear across that switch, one can choose a relatively small-size model which has a low commercial voltage rating, e.g. as in Table A.I.

4.6 Measuring devices and ground connection

Because of the high voltages involved, measuring devices (see Table 4.5) are either housed in the switching units cubicle and/or galvanically separated from the discharge circuit.

Table 4.5

Measuring facilities

1. Requirements

1.1 Voltmeter, pointer instrument

Signal	Pointer deflection
Over-all accuracy	±2%
Scale, linear	0-13 kV
Full-scale deflection within	200 msec

1.2 Current transformer with iron core

Signal, proportional to primary current	10.0 V secondary for 10.0 kA primary
Over-all accuracy (1-60 kA primary)	±1%
Phase shift, max.	±0.2°
Frequency range	1-10 kHz
Primary current range	0-60 kA
Permissible overcurrent	150 kA
Current rise-time ($\frac{1}{4}$ sine wave), min.	80 μ sec
Current tail (exponential decay to 10%), max.	500 μ sec
Current-time integral, primary, max.	15 Asec
Impedance of measuring device	75 Ω

2. Proposed solution

2.1 Moving coil voltmeter with voltage divider,
e.g. as in Table A.I.

2.2 Toroidal current transformer

Current ratio	300:1
Number of turns	Primary 1 Secondary 300
Core material	Silicon grain oriented iron
Core dimensions ID	31 mm
OD	62 mm
width of iron tape	25 mm
enamel layer	0.5 mm
tape thickness	0.3 mm
air gap	2 × 0.07 mm

Table 4.5 (cont.)

Measuring facilities

Winding conductor (copper) diameter	0.8 mm
Winding resistance, approx.	1 Ω
Terminating resistance	0.300 Ω
Type of term. resistance	Painton MV1A, or equivalent
Cooling	still air
Duty ratio	$< 10^{-3}$
Inductance in iron core at 50 kA, approx.	1.2 Wb/m²

A fast responding voltmeter, connected by means of a voltage divider across the capacitor terminals, is incorporated in each switching unit. Three current transformers are built into different branches of the circuit for measuring the following quantities separately: the current in the capacitor bank; the current through the magnet; and the current through the crow-bar resistor. Physically these transformers are mounted close to the earthing point for safety reasons. Technically they consist of: the primary winding, represented by a bolt connecting two busbars in the main circuit; an iron core with a sufficiently large cross-section so as not to go into saturation for primary currents up to 60 kA, and with an air gap to keep the remanence down and to enhance linear response; and a termination resistor of 0.3 Ω . The transformer in the magnet branch is reserved for precise current measurement only. The external measuring equipment (e.g. precision oscilloscope) permits measurement of the current of each section singly, as well as the total current of the system. The other current transformers are needed for displaying the current waveforms and for supplying signals for the electronic fault detection and protection circuits.

Each discharge switching circuit is grounded singly by a separate heavy current cable to the central building earth. No other connection to ground of less than 1 M Ω is permitted for any part of the 12 kV circuit. This holds for the switching units, as well as for the charging supply and the magnet. As shown in Drawing NPA 224-133-3C, the negative side of the capacitor is connected to ground at the point where the crow-bar circuit branches off.

The cabinet structure of each switching unit is also connected to the central building earth, and by no means to the circuit inside it.

4.7 Cabinet layout

The energy storage and discharge switching assemblies are self-contained cabinet-type units, located some distance away from the magnetic horn and the reflectors in a separate building in order to avoid nuclear radiation problems. For safety reasons, i.e. to reduce possible damage due to capacitor or connector explosion, etc., these units are completely enclosed with sheet metal (Photo 195-5-69) in such a way that they can be safely touched when in operation. The ignitron anodes can be inspected

through a safety glass window in the front panel. The top cover is made so that the heavy-current cables, including their connectors, can be put into and taken out of the unit easily, and that enough natural air convection is possible to cool those components of the circuit that are not water cooled.

The interior of the cabinet is essentially divided into two regions (Photo 194-5-69). The larger one, in the rear, houses the energy storage capacitor units. The switching circuitry is located in the front part where the ignitrons and the polarity switch are arranged in such a way that they can be exchanged and operated, respectively, with greatest possible ease when the front panel is removed. Access from the sides may never be required. The ignitron anodes are each heated by a 250 W infrared lamp.

In the cooling water loop, the crow-bar ignitron is connected in series behind the main ignitron. The cooling water hoses are fitted with snap-on connections, which seal themselves automatically when taken off.

All heavy-current connections inside the cabinet are of low-inductance, low-resistance design using large cross-section copper-bar strip-lines whenever possible. Special attention must be paid to the mechanical rigidity of all these connections because of the strong magnetic forces associated with the high pulse currents. In particular, the strip-lines have to be compressed by rigid clamps exerting a high pressure. The total inductance of the unit when short-circuited at the cable connectors is less than 1.0 μH .

Since the ignitrons are a source of strong acoustical noise, they are mounted on rubber pads and connected to the circuit by means of braided conductors. The cabinet walls next to the ignitrons are covered with non-flamable sound-absorbing material.

For the purpose of standardization all low-voltage connectors should be of CERN standard type. The selected connectors are listed below.

1. Current transformer signals : BNC 50 Ω
2. 24 d.c. for high-voltage switch and aux.
contacts : Burndy, type
UTO 2-14-12P-5T
3. Trigger pulse input : Cannon, type
MS 3102A 18-16P
4. 220 V for infrared lamps : Metronic AG, Zurich;
plug fixed 3 poles,
6 A 250 V.

The energy storage compartment of the cabinet must be suitable for accommodating capacitor containers of different shapes and sizes (Bosch, BICC, etc.) up to a total amount of 20 kJ. The detailed fixing structure must therefore be of a screwed and not of a welded construction. For dimensioning the cabinet, the following dimensions may be assumed for the capacitors (terminals and fixing brackets included): 820 mm \times 160 mm \times 650 mm. A container of this size usually accommodates 2-3 kJ, depending on the execution.

The cabinet must be equipped with eye-bolts for lifting by crane, and have a robust base structure with 120 mm high legs in order to permit easy transport by fork-truck. Front and back panels must be removable.

The equipment must be constructed in such a way that all components can be easily inspected, tested, or exchanged. The execution must conform to up-to-date techniques and standards as required so as to ensure a high degree of reliability under the load condition specified.

The construction must comply with normal safety practice and regulations, and the equipment should be suitably protected so that it can be operated without hazard by experimental personnel possessing no special knowledge of the system.

5. LOW-INDUCTANCE HIGH-VOLTAGE PULSE CABLES AND CONNECTORS

5.1 Cables

The energy storage and discharge switching units are located outside the radiation area at a distance of 50-100 m from the magnets (horn and reflectors), depending on the experimental layout, which is changing from

time to time. A typical installation layout is shown in Drawing 224-244-0.

Also, it is desired that as much as possible of the total energy $\frac{1}{2}CU^2$ accumulated in the storage capacitors should be transferred to the magnet, and this requires that the total inductance of the transmission cables should be small compared to the approximately 1.0 μH inductance of the magnet. It is considered reasonable to admit an inductive energy loss of 10% in a 50 m long transmission system. This corresponds to an inductance of 2.0 nH/m, which could in principle be achieved by means of a parallel-plate ("strip-line") type of transmission line, but a parallel array of flexible low-inductance coaxial cables has been preferred.

A cable inductance of 50 nH/m is proposed as the most practical solution, assuming two parallel cables for each of the twelve energy storage and switching sections. This arrangement has also been used with satisfactory result in the existing R2 and R3 systems. A single cable per section of 25 nH/m would also be acceptable, and would also have the advantage of requiring only half the number of connectors; however, such a cable would be inconveniently rigid and heavy to handle, and would presumably be a less economical solution.

More detailed data of the preferred cable are listed in Table 5.1.

In addition to the essential requirements of low inductance and high current-carrying capacity for high-voltage pulse duty, the cables must also be made with an insulation that can withstand intense nuclear radiation without being damaged too rapidly. Paper, oil, and the most radiation-sensitive plastic materials (Teflon, PVC, etc.) should therefore be excluded. A special radiation-resistant material would be preferred, if this could be combined with the high-voltage low-inductance requirements at a reasonable cost. An insulation of polyethylene is acceptable as an economical compromise solution.

The small inductance value of 25 nH per loop metre for each section or 50 nH/m for each cable assuming two cables per section, requires a ratio (insulation thickness)/(perimeter) = 0.01 (approximately). Clearly the insulation must therefore be very thin in order to limit the cross-sectional size of the cable, and it must also be of a very high and uniform quality so as to withstand the voltages involved.

There is no restriction on the capacitance of the cable, since it will in any case be small compared to that of the energy storage capacitors.

There is no practical restriction on the resistance and conductor cross-section of the cable, except that the cable must be suitably dimensioned for the pulse currents specified both for normal operation and for fault conditions.

The outer conductor must be insulated for the full 12 kV voltage against earth, since current polarity reversal will be carried out at the supply end of the cables until a satisfactory solution has been found for a remotely controlled reversal switch located at the magnet end. An additional outer coating is required as protection against mechanical damage.

5.2 Connectors

The cables will be connected perpendicularly to closely spaced parallel collector plates (Drawing 224-455-3) by means of special coaxial connectors (Photo 299-5-69). The end joined to the collector plates of the magnetic horn or reflectors is exposed to radiation, and therefore all insulating pieces of the connectors must be radiation resistant and easily exchangeable in case of damage. Outline dimensions are standardized to make the connectors interchangeable between the three capacitor discharge systems of the magnetic horn R1 and reflectors R2 and R3.

Constructional details of the connectors are shown in Drawing 224-458-2.

Acknowledgements

Direct or indirect contribution to the work for the pulsed current supply system for the magnetic horn and reflectors of the CERN neutrino beam in the PS South-East Area has been made by G. Acquistapace, A. Ball, G. Davies, P. Del Rey, M. Etienne, R. Gerst, J.J. Hirsbrunner, J. Hözer, J.M. Maugain, J.M. Michaud, J. Perez, H. Pflumm, F. Völker, J. Zaslavsky of the NPA Pulsed Beam Transport Group, with the general support, encouragement and advice of C.A. Ramm, Division Leader. Useful collaboration with J.C. Dusseux, G. Griot, B. Pattison, W. Venus, W. Wachsmuth, G. Ziebarth, and many present and past members of the experimental teams and technical services is acknowledged.

REFERENCES

- 1) C.A. Ramm, Development of high-energy neutrino experiments at CERN, Nature 217, 913 (1968).
- 2) A. Asner and Ch. Iselin, A new focusing system considerably increasing the actual PS neutrino beam flux density, CERN 65-17 (1965), and Layout of the new neutrino beam, CERN 66-24 (1966).
- 3) R. Bartolotto, D. Bloess, R.C.A. Brown, R. Grüb, B. Langeseth, J. Mann, J.M. Maugain, J.B.M. Pattison, H. Pflumm, G. Plass, D. Rusch, K.M. Vahlbruch and H.W. Wachsmuth, Performance of the new neutrino beam at the CERN Proton Synchrotron, Proc. 6th Int. Conf. on High-Energy Accelerators, Cambridge, Massachusetts (1967).
- 4) B. Pattison, The CERN neutrino beam, Proceedings of Informal Neutrino Conference, CERN, January 1969 (to be published).
- 5) S. Van der Meer, A directive device for charged particles and its use in an enhanced neutrino beam, CERN 61-70 (1961).
- 6) A. Asner, The focusing system of the new neutrino beam-line of CERN, Proc. 2nd Int. Conf. on Magnet Technology, Oxford (1967).
- 7) M. Giesch and S. Van der Meer, The 150 kJ capacitor bank of the magnetic horn, CERN 66-16 (1966).
- 8) B. Langeseth, Specification for energy storage capacitor battery, CERN Internal Note NPA/PBT 15.6.1965;
Specification for high-voltage low-inductance pulse power cables, CERN Internal Note NPA/PBT 22.7.1965 (I-3816/NPA);
and
Specification for power supply for capacitor charging, CERN Internal Note NPA/B/BL/fv 13.4.1965 and Addendum NPA/PBT/BL/sd 10.5.1965.
- 9) H. Pflumm, d.c. charging supplies for reflectors R2 and R3 (to be published);
and
Current-measuring circuits and protection interlocks for reflectors R2 and R3 (to be published).
- 10) B. Langeseth and F. Völker, d.c. power supply for charging of a 12 kV 200 kJ energy storage capacitor battery of a 500 kA pulse system for the magnetic horn and reflectors of the CERN neutrino beam, CERN Internal Report NPA/Int. 68-25 (1968).
- 11) J. Høyer and J. Zaslavsky, Control electronics for 500 kA pulsed current supply system (in preparation).
- 12) L. Caris, Private communication from CERN, Proton Synchrotron Division, Geneva, Switzerland.

- 13) D.L. Smart, Private communication from Culham Laboratory, Culham, England.
- 14) P.L. Davies, Private communication from Westinghouse Brake and Signal Comp., Electrical Research Laboratory, Radlett, England.
- 15) H. Pflumm, Switching capability of power thyristors for high-current pulses of short duration, CERN Internal Report NPA/Int. 69-12 (1969).

DATA ON THE EXISTING PULSE SYSTEMS

In order to facilitate the design and selection of components for new pulse systems, the most important components used in the existing R1, R2, and R3 pulse systems are listed in Table A.I below.

Certain of these items have also been used in the new prototype module.

Table A.I

Components used in the existing equipment

1. Energy storage capacitors : a) Type MP-K03GH416, 17.4 μ F, 1.180 kJ, 11.6 kV. Robert Bosch GMBH, Stuttgart, Germany.
b) Type CX3040, 2 \times 23.4 μ F, 2 \times 1.685 kJ, 12.0 kV. BICC, Holsby, Cheshire, UK.
2. Main discharge switch : a) Ignitron type BK178 and type BK478 (co-axial). English Electric Valve Co., Ltd., Lincoln, UK.
: b) Ignitron type TH7040, type TH7043, and type TH7040Z (special model). Thomson Houston, Thonon-les-Bains, France.
: c) Ignitron type PL5553 and type PL 5555. Philips, Eindhoven, Netherlands.
: d) Ignitron type NL-1095. National Electronics Inc., Geneva, Illinois, USA.
: e) Ignitron type AJ5553 B. AEG, Frankfurt, Germany.
3. Crow-bar switch : As for main discharge switch.
4. Auxiliary discharge switch : Made to CERN Drawing NPA 224-325-3A.
5. Safety switch : Type CA201A, 13/2 short, 1 kV - 250 A - 1 pole. Gardy S.A., 1211 Genève 13, Switzerland.
6. Energy dump resistor : Made to CERN Drawing NPA 224-456-2, using 1 k Ω , 1 kW continuous duty, wire mesh type resistor. Schniewindt, D 5982 Neuenrade, Germany.

6. Energy dump resistor (cont.) : b) Made to CERN Drawing NPA 224-457-2, using 8 discs type Y763, $150 \Omega \pm 20\%$. Morganite Resistors Ltd., Bede Industrial Estate, Jarrow, County Durham, England.
7. Low-inductance HV pulse cable : a) Type KV5037, 40 nH/m. Datwyler A.G., Altdorf, Switzerland.
: b) Type special, 55 nH/m. Les Câbles de Lyon, Lyon, France.
8. HV cable connectors : Made to CERN Drawing NPA 224-458-2 by R. Merz, 13 ch. des Coquelicots, CH 1214 Vernier/GE, Switzerland.
9. Current transformers : a) Toroidal air-core pick-up coils and electrical integrator. This type will be replaced by b) or similar.
: b) Current transformer made to CERN Drawing NPA 224-326-3A. Tests on this TYPE are not concluded.
10. Crow-bar resistor : Made to CERN Drawing NPA 224-448-3, by A. Besson, CH 1260 Nyon, Switzerland.
11. Components of ignitron firing circuit in discharge unit : a) Isolating transformer type EAB-W1224. Elektro-Apparatebau AG, CH 2608 Courtelary/ BE, Switzerland.
: b) Capacitor type Erie 5000, P AN 3000 VW.
: c) Diode type AEG SI 03 N.
: d) Resistor 5.6Ω type Painton P200 IF, 2.Y.C.
12. Components of self-firing circuit : a) Diode type Silec P200 H.
: b) Resistors: 10Ω , 100Ω , $1 \text{ k}\Omega$, Painton, 6 W.
: c) Capacitor $0.05 \mu\text{F}$ type Bosch MP, 2.5/3.75 kV.
13. Ignitron anode heater : Infrared lamps, 250 W. Philips, Holland.
14. Water flow monitor : Type V1-G15. Eletta, Segeltorp, Sweden.
15. Water hose connectors : Type T2SI. Walter Präz., Wuppertal, Germany.

- 16. Voltmeter : Type DQ48R (200 msec full scale), 12 kV voltage divider. Müller and Weigert, D8500 Nürnberg, Germany, Kleinreuther Weg 88.
- 17. 24 V d.c. connector : Type UTO 2-14-12P-5T. Burndy.
- 18. Trigger pulse connector : Type MS3102A 18-16P. Cannon.
- 19. 220 V a.c. connector (for IR lamps) : 3 pole, 6A, 250 V plug fixed. Metronic AG, Zürich.
- 20. Coaxial cable connectors : BNC 50 Ω .

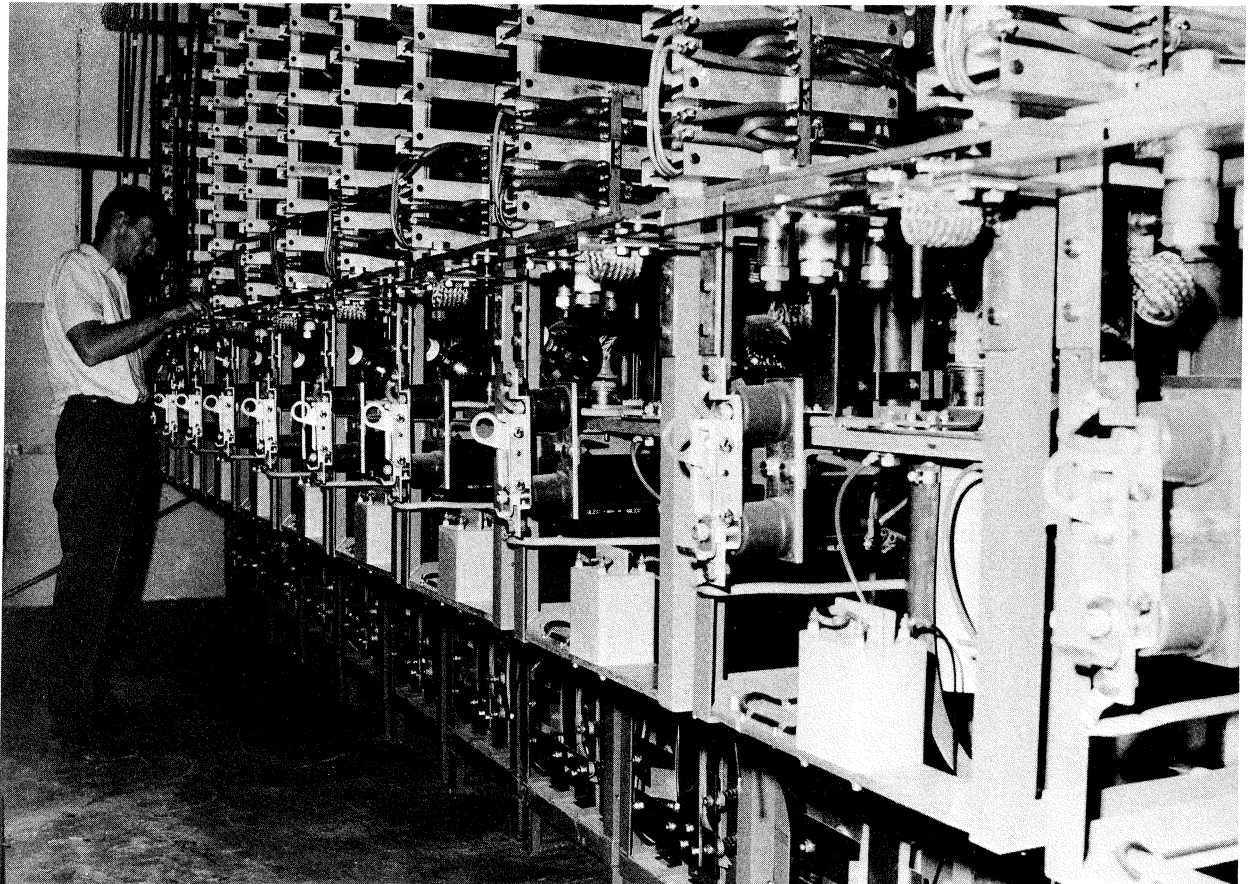

THE 130 kJ CAPACITOR DISCHARGE INSTALLATION (consisting of 13 parallel branches).Photo CERN n° 96_9_66

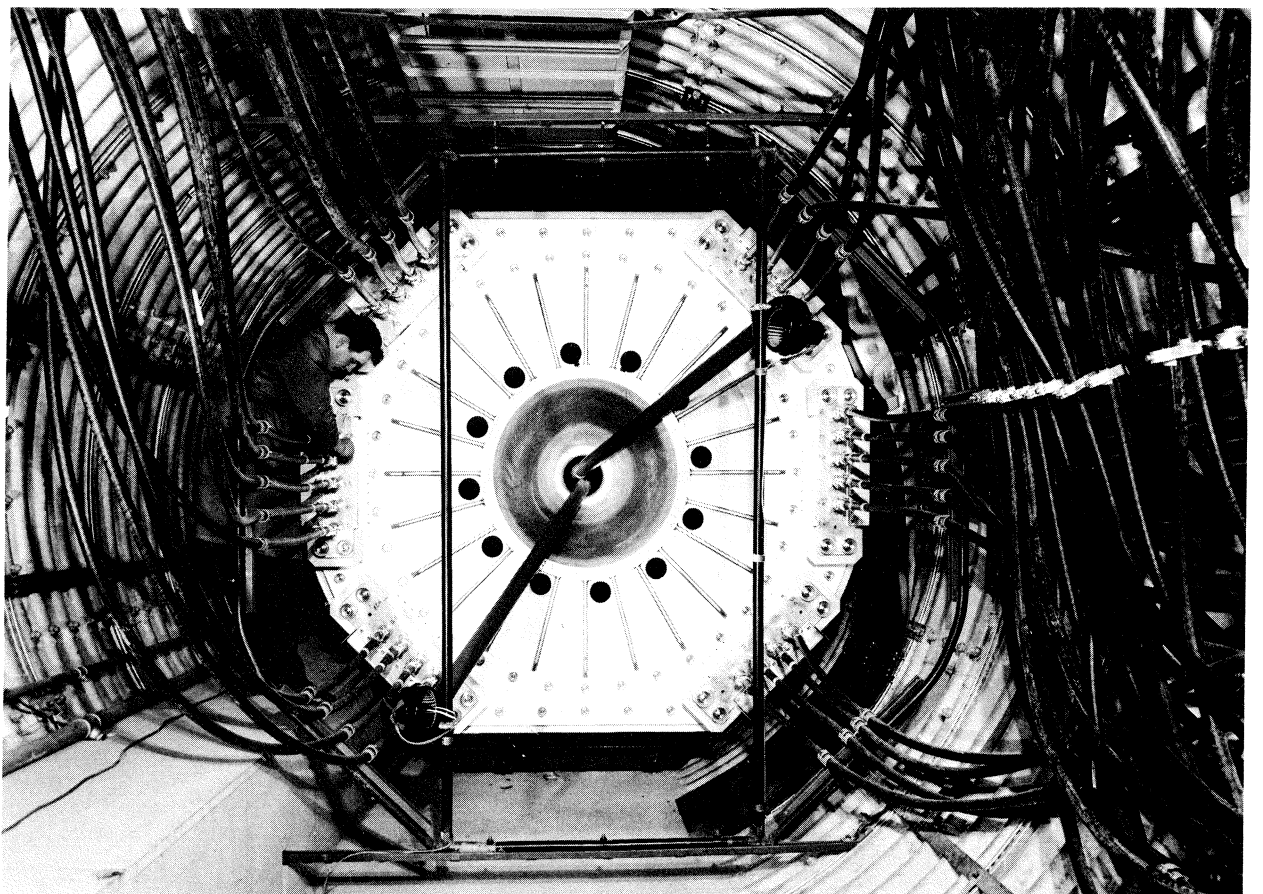

PULSE CABLE CONNECTIONS TO REFLECTOR R 2.
Photo CERN n° 46_6_67

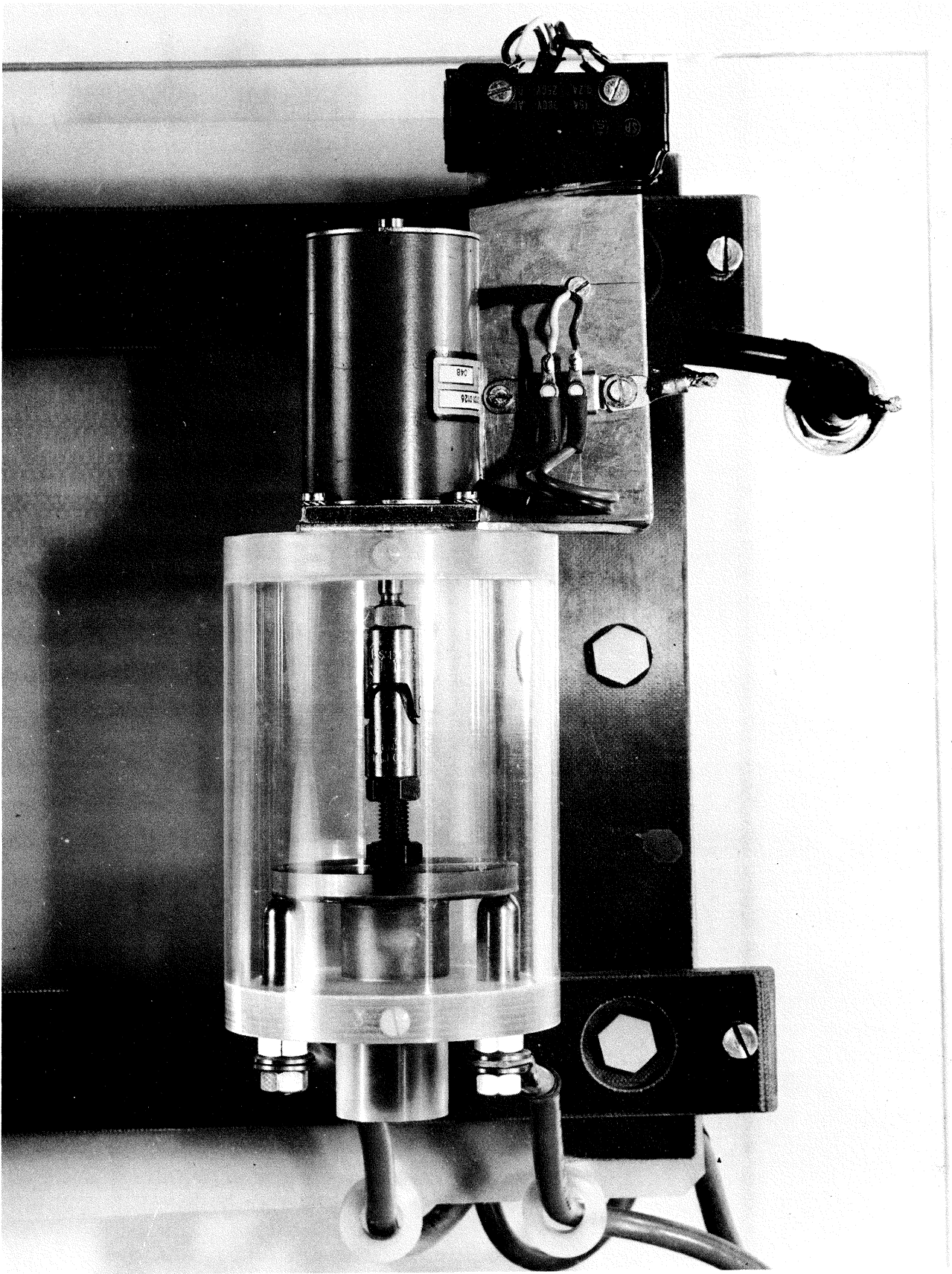

HIGH VOLTAGE SWITCH. Photo CERN n° 26_11_66

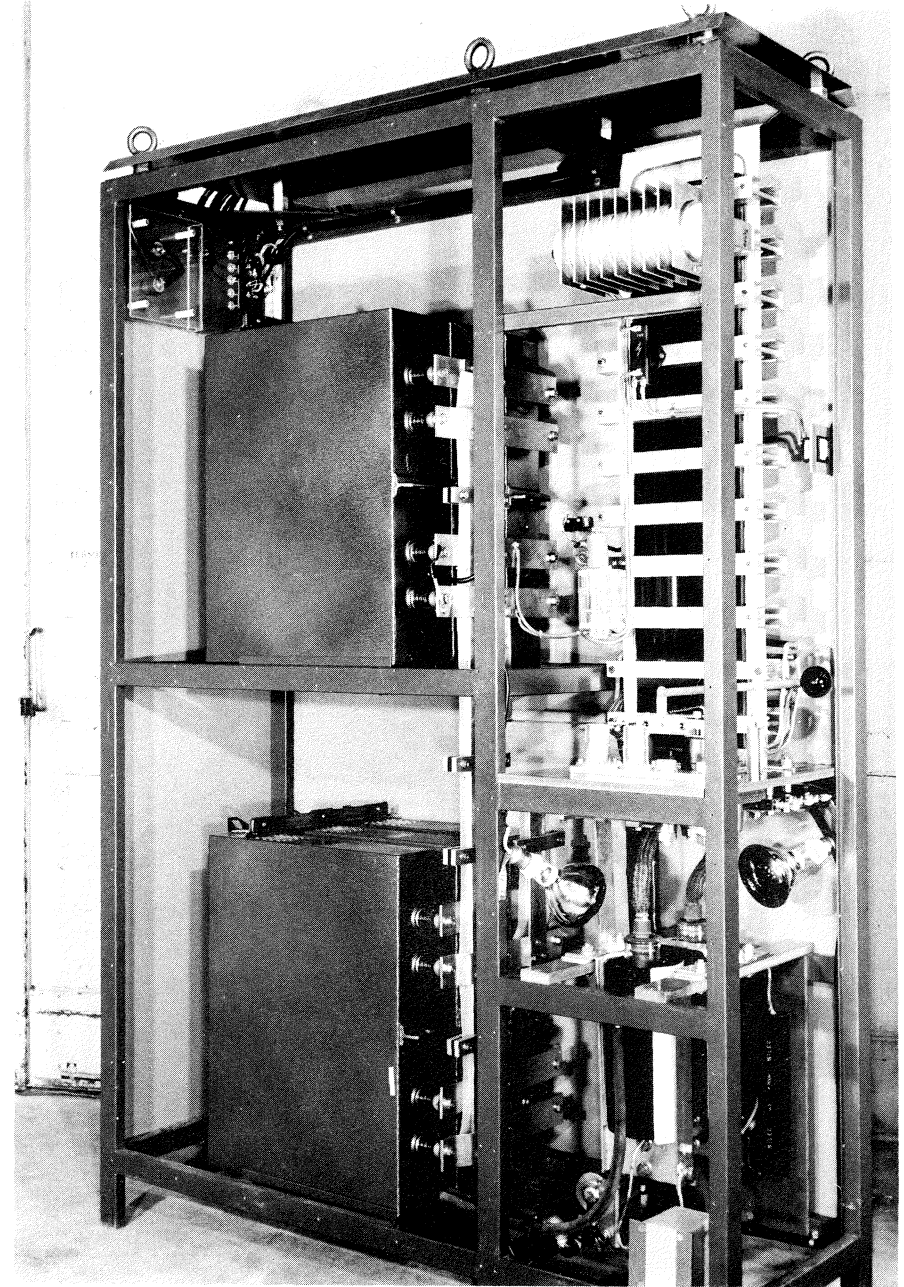
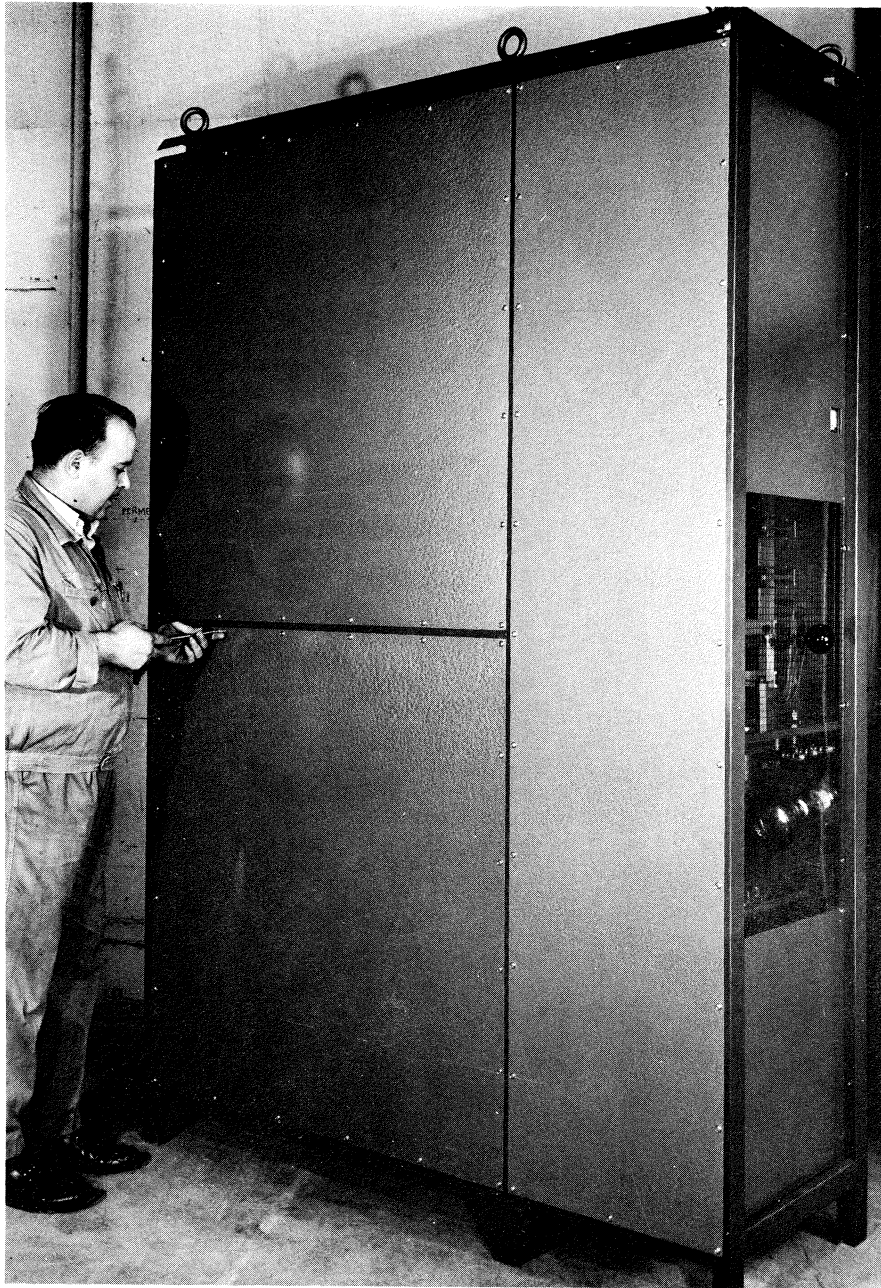

ENERGY STORAGE AND DISCHARGE SWITCHING ASSEMBLY MODULE (MODEL CLOSED).

Photo CERN n° 195.5.69 and n° 194.5.69

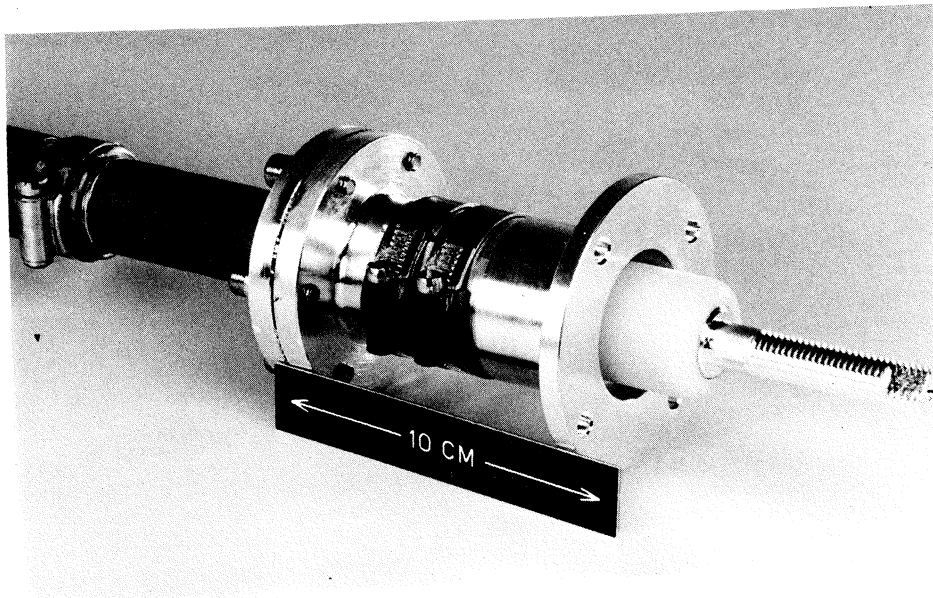

HIGH VOLTAGE COAXIAL CONNECTOR
Photo CERN n° 299.5.69

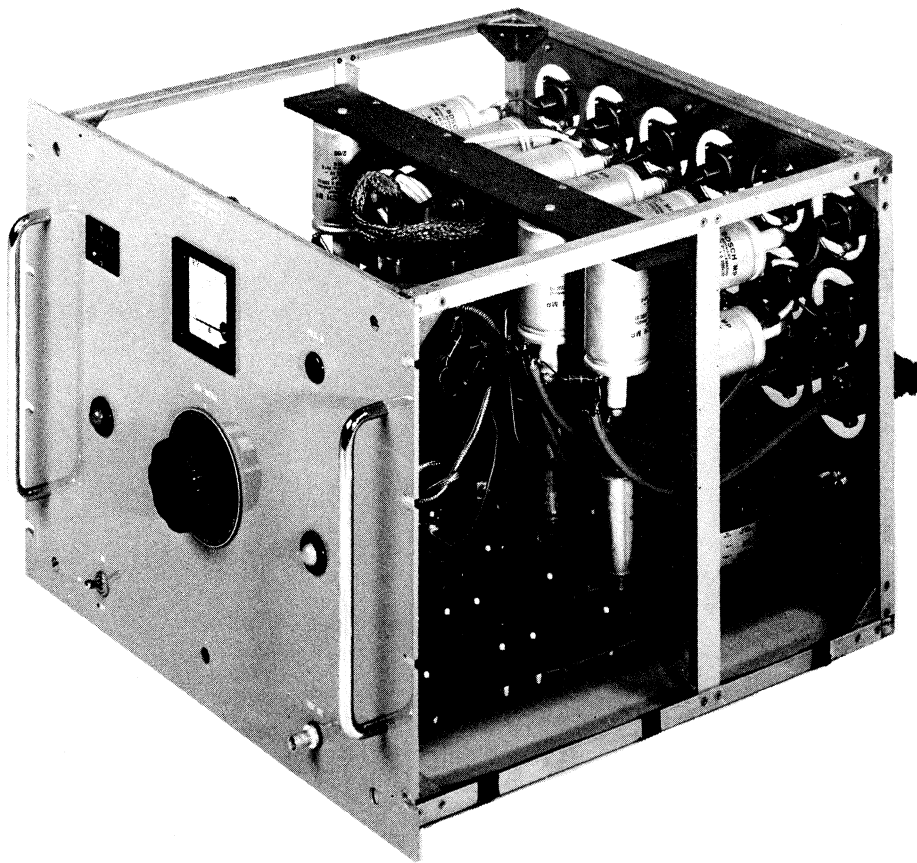

TRIGGER UNIT. Photo CERN n° 286.5.69

TV	SCINTILLATING SCREEN VIEWED BY TELEVISION
BPM	BEAM POSITION MONITOR
BCT	BEAM CURRENT TRANSFORMER
Q	QUADRUPOLE
VD	VERTICAL DEFLECTING
HD	HORIZONTAL DEFLECTING
BS	BEAM STOPPER
BIM	BEAM INTENSITY OR LOSS MONITOR

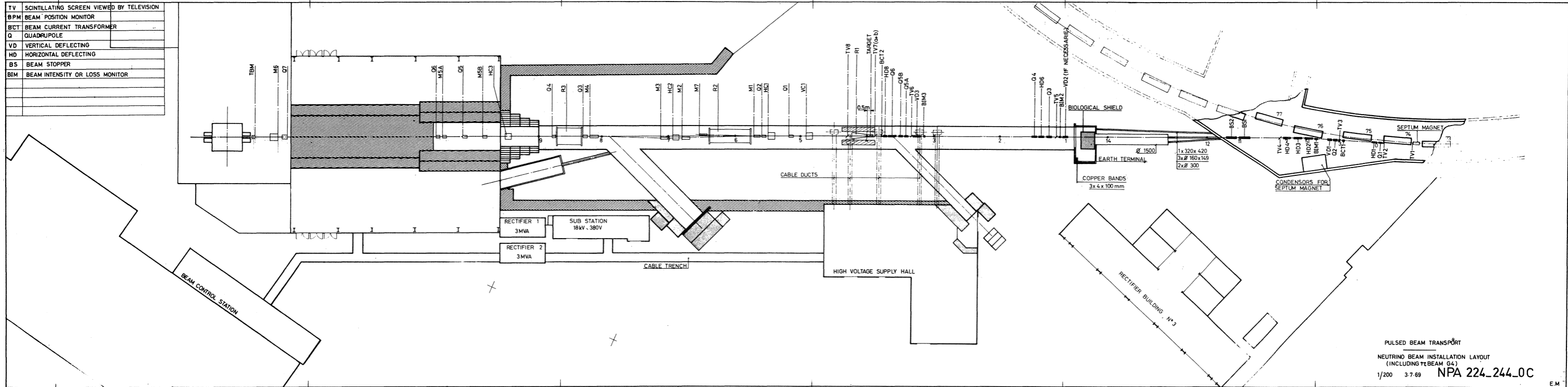

PULSED BEAM TRANSPORT
 NEUTRINO BEAM INSTALLATION LAYOUT
 (INCLUDING TELEBEAM G4)
 1/200 3-7-69 NPA 224_244_0C E.M.

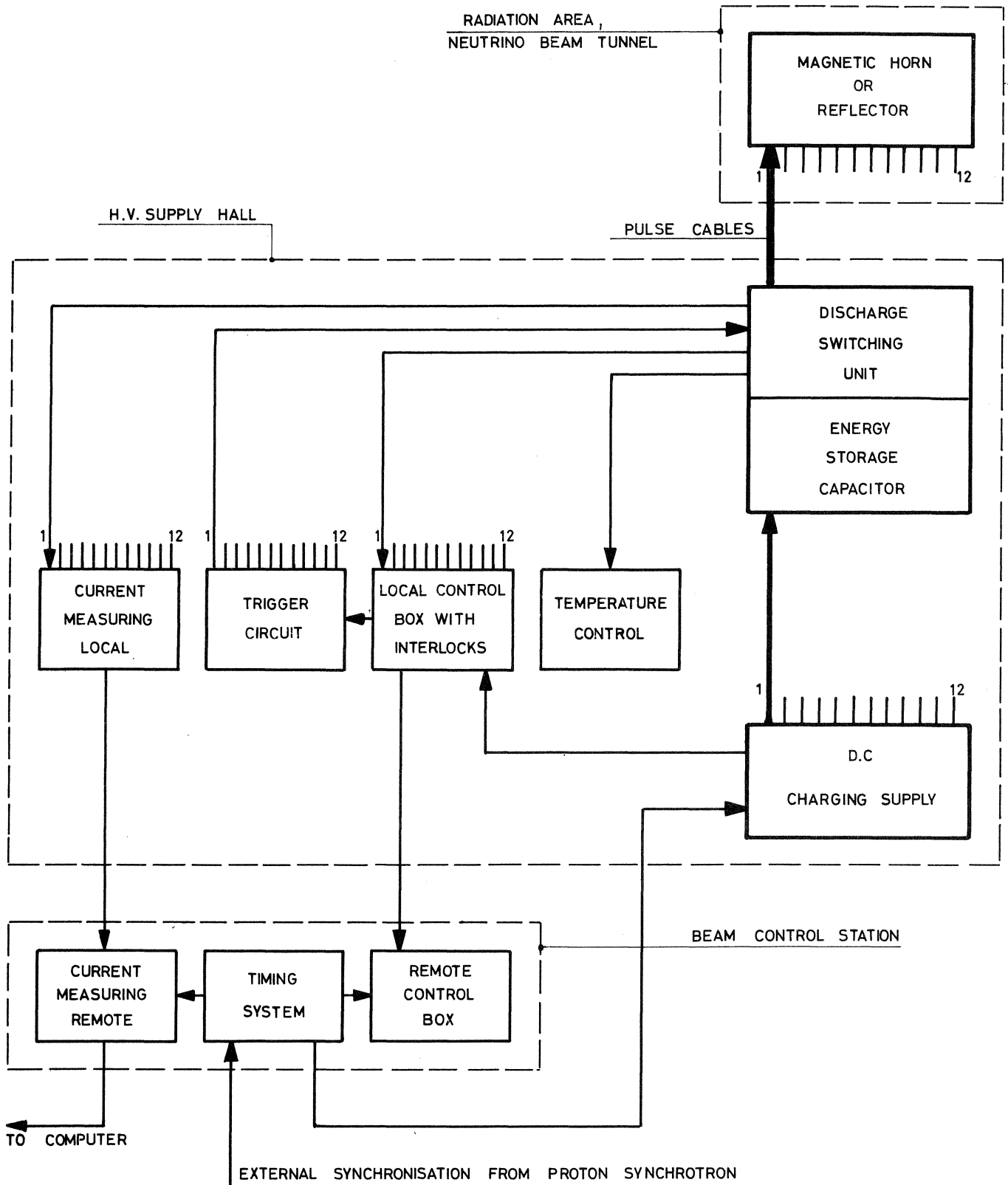

BLOCK DIAGRAM OF 500 kA PULSED
CURRENT SUPPLY SYSTEM FOR MAGNETIC
SEPTUM LENS (magnetic horn or reflector)

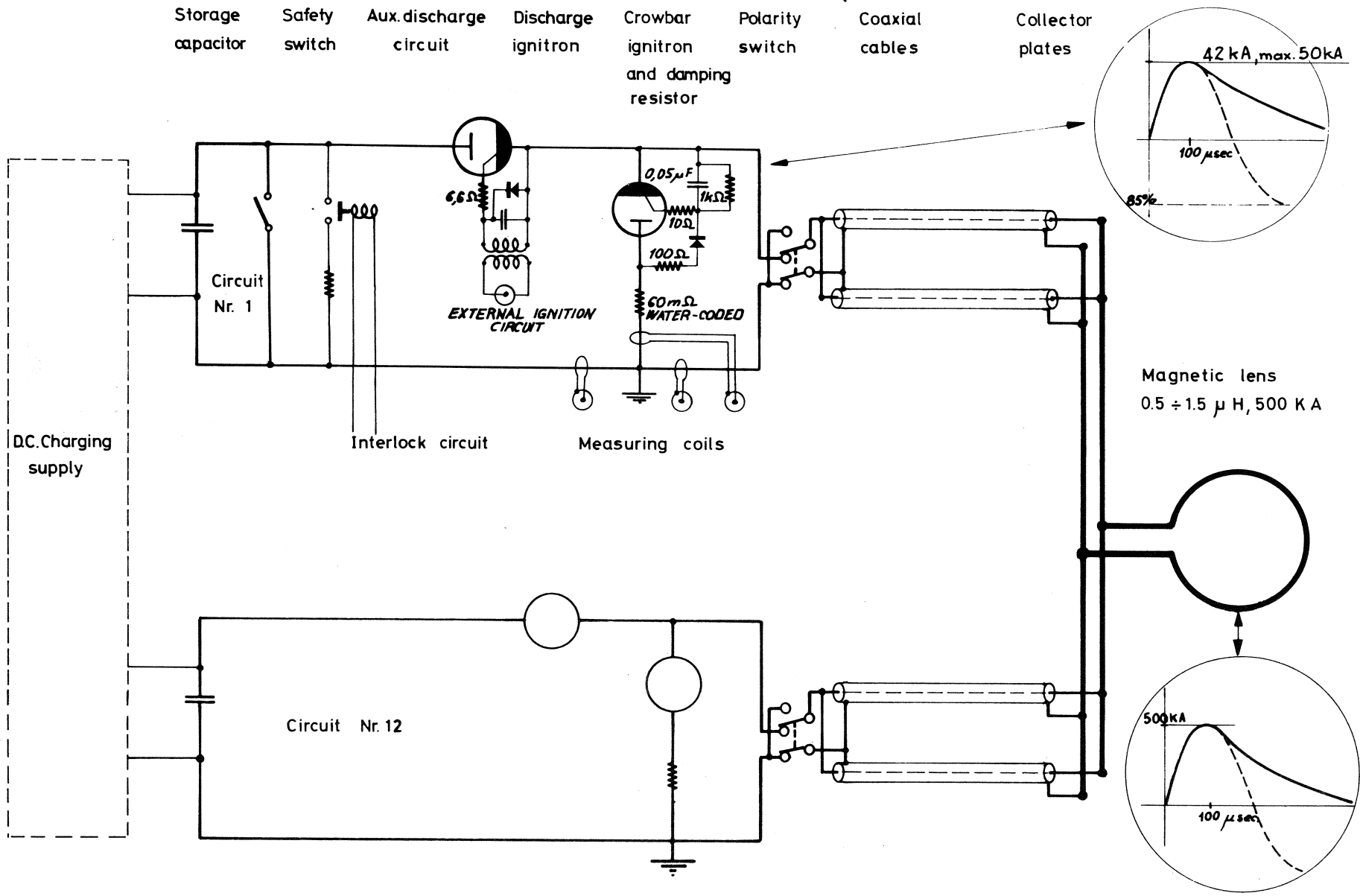

DISCHARGE CIRCUIT DIAGRAM

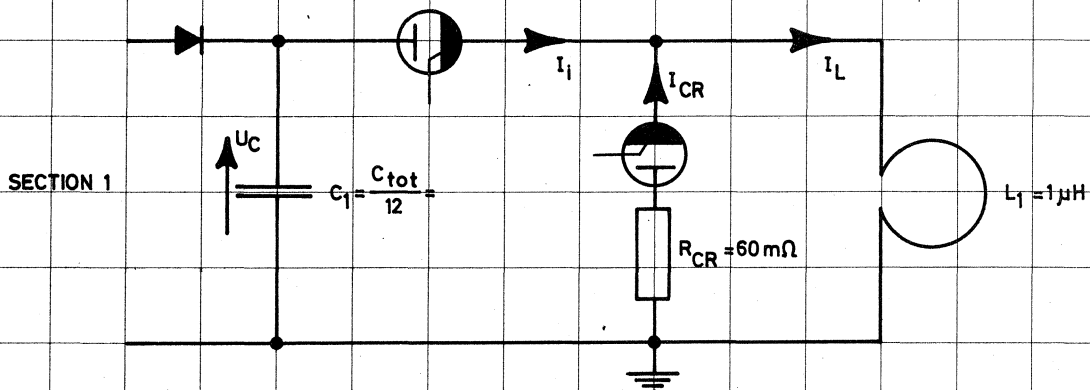
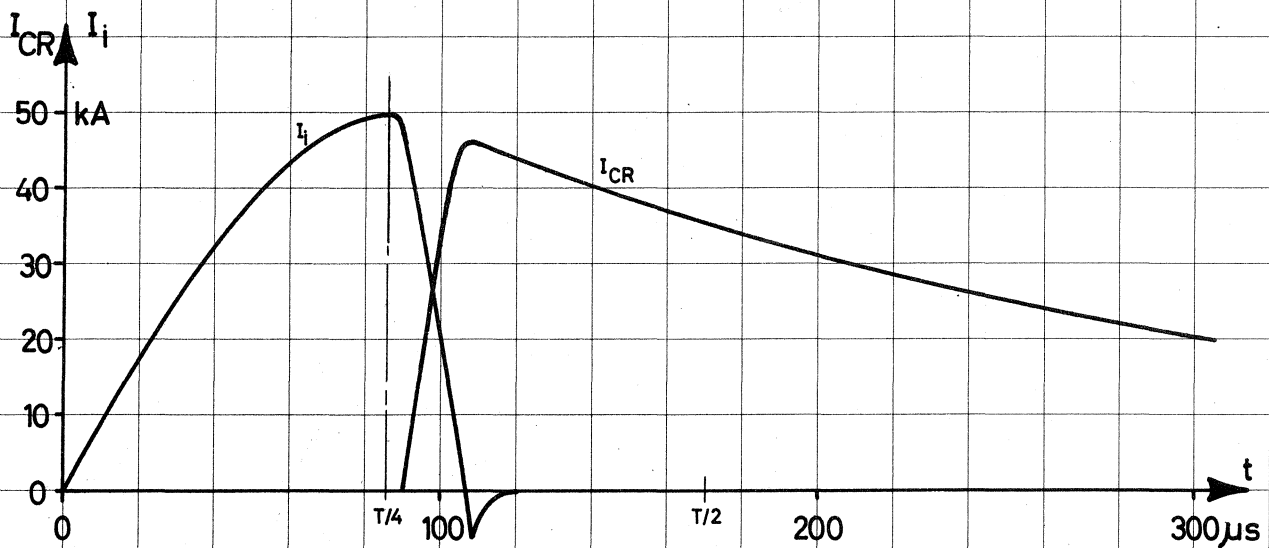
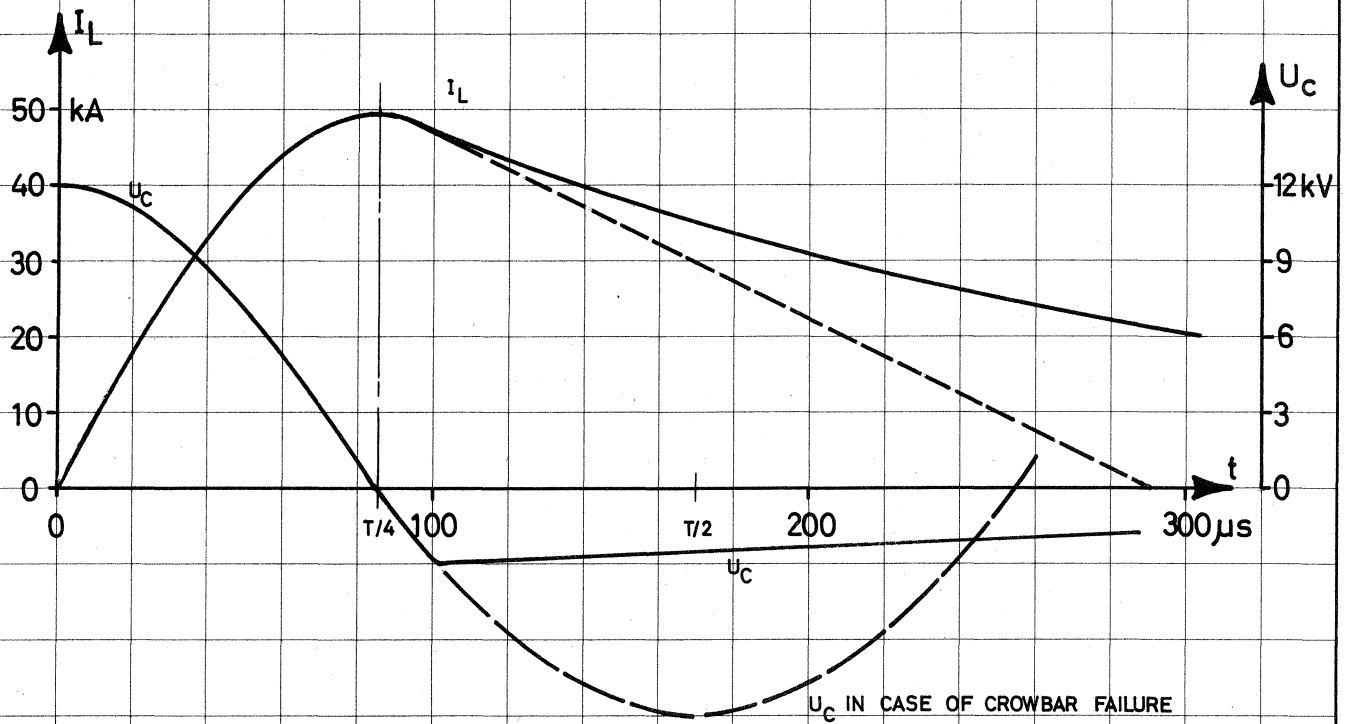

Currents and voltages
in the discharge circuit

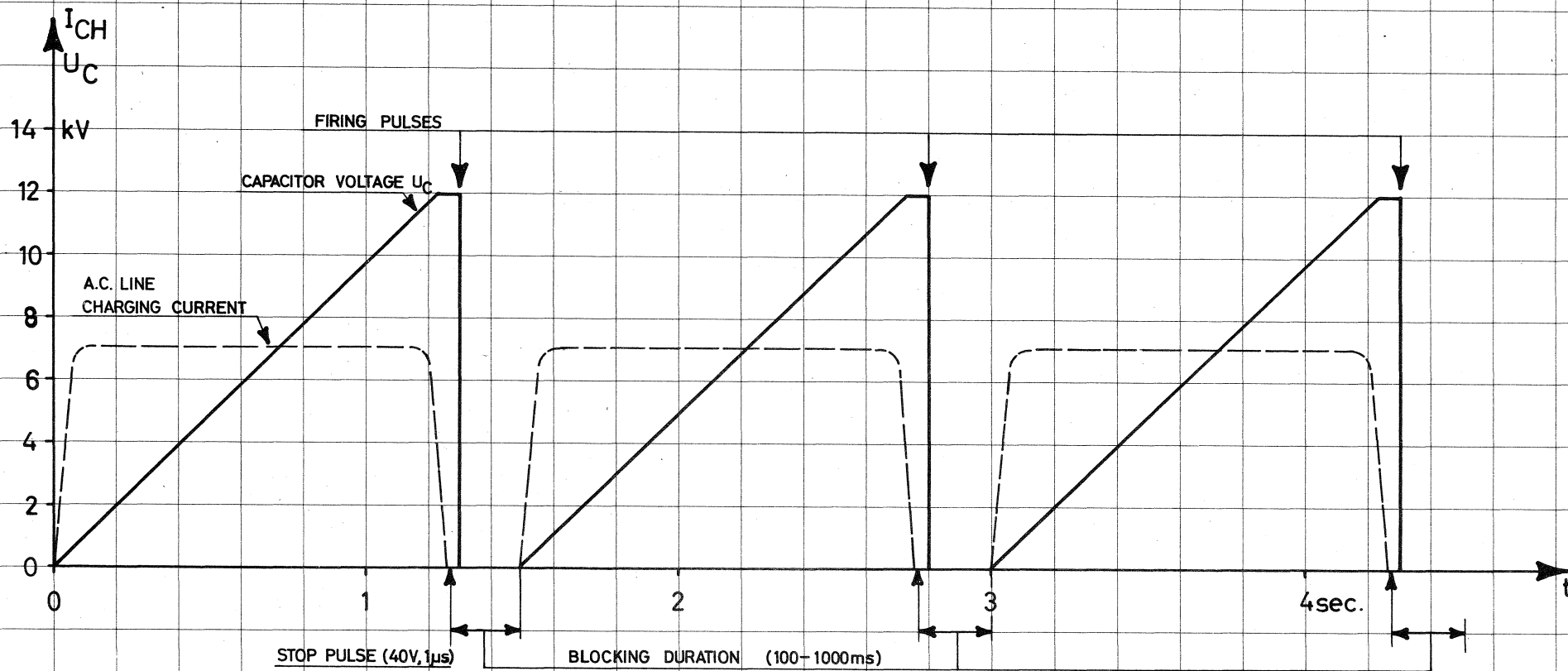

Capacitor voltage as function of time

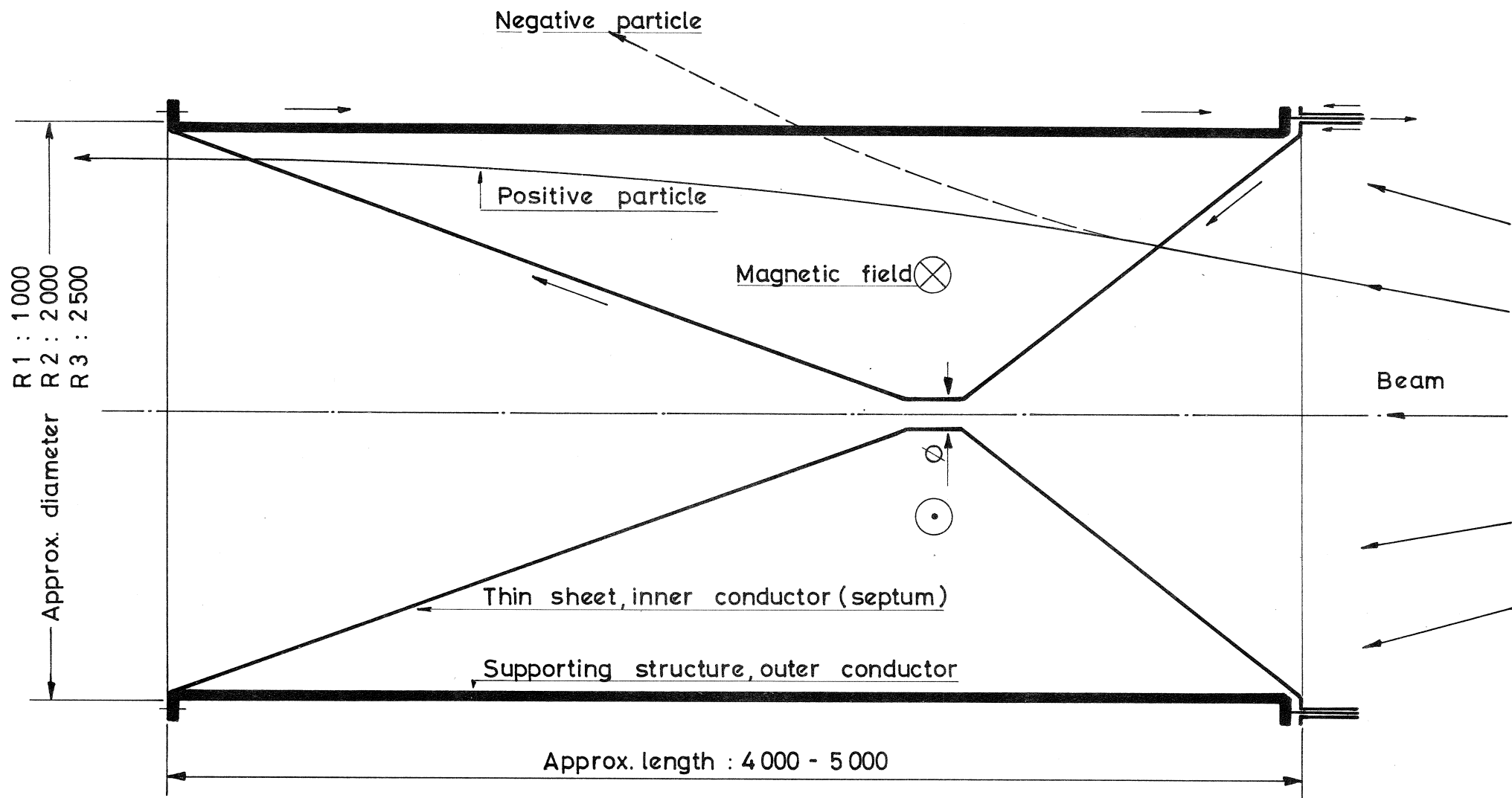

COAXIAL SEPTUM LENS
(Magnetic horn or reflector)

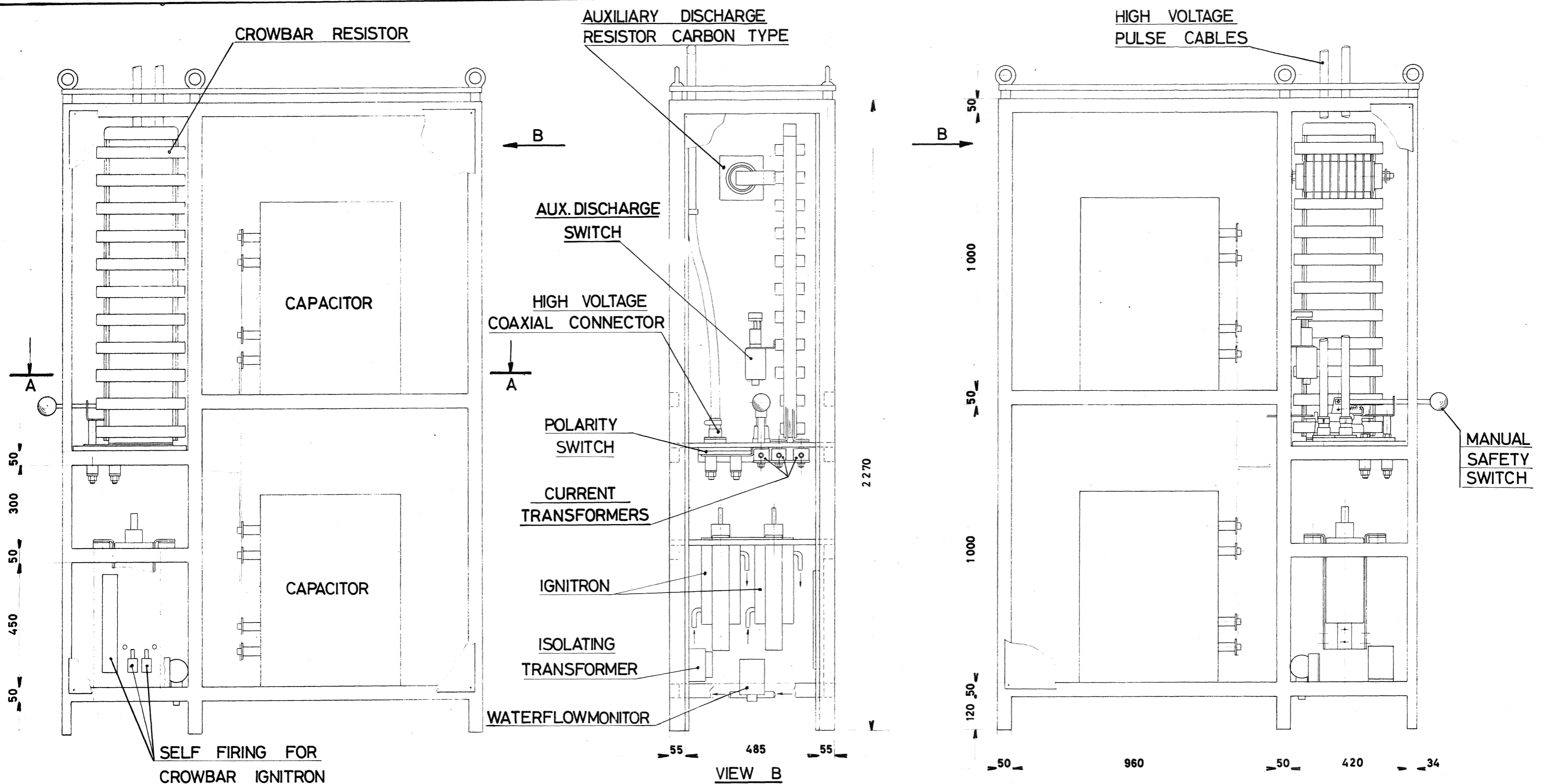

SECTION A

VIEW B

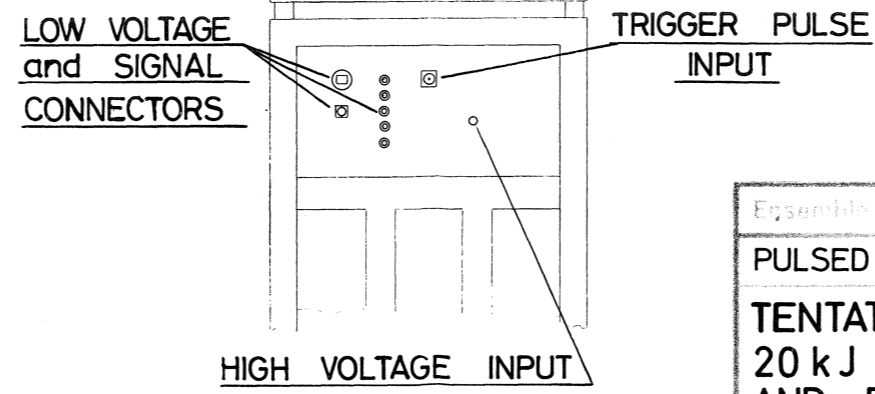
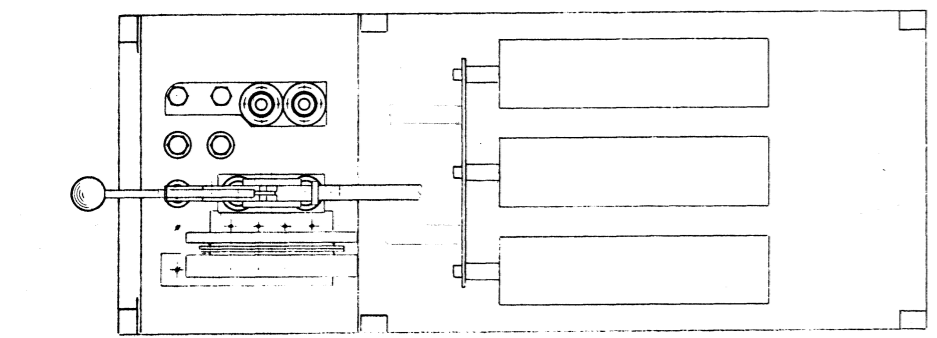

Ensemble	G Ensemble	Dessiné	J.P	5.69
PULSED BEAM TRANSPORT		Contrôle		
TENTATIVE CABINET LAYOUT FOR 20 kJ ENERGY STORAGE CAPACITOR AND DISCHARGE SWITCHING ASSEMBLY		Vu		
ORGANISATION EUROPEENNE POUR LA RECHERCHE NUCLEAIRE CERN EUROPEAN ORGANIZATION FOR NUCLEAR RESEARCH		Remplace		
		Remplacé par		
				224-443.3

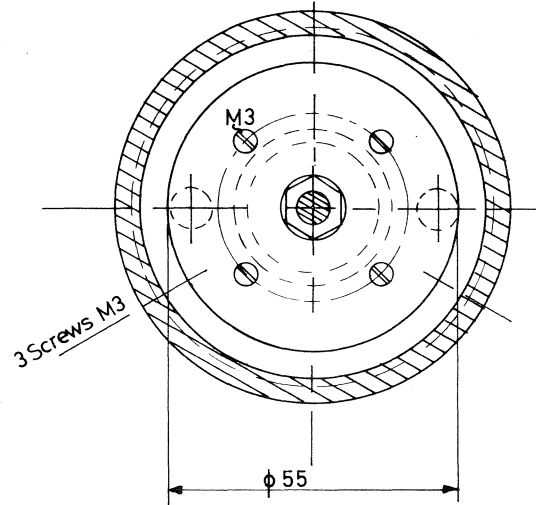
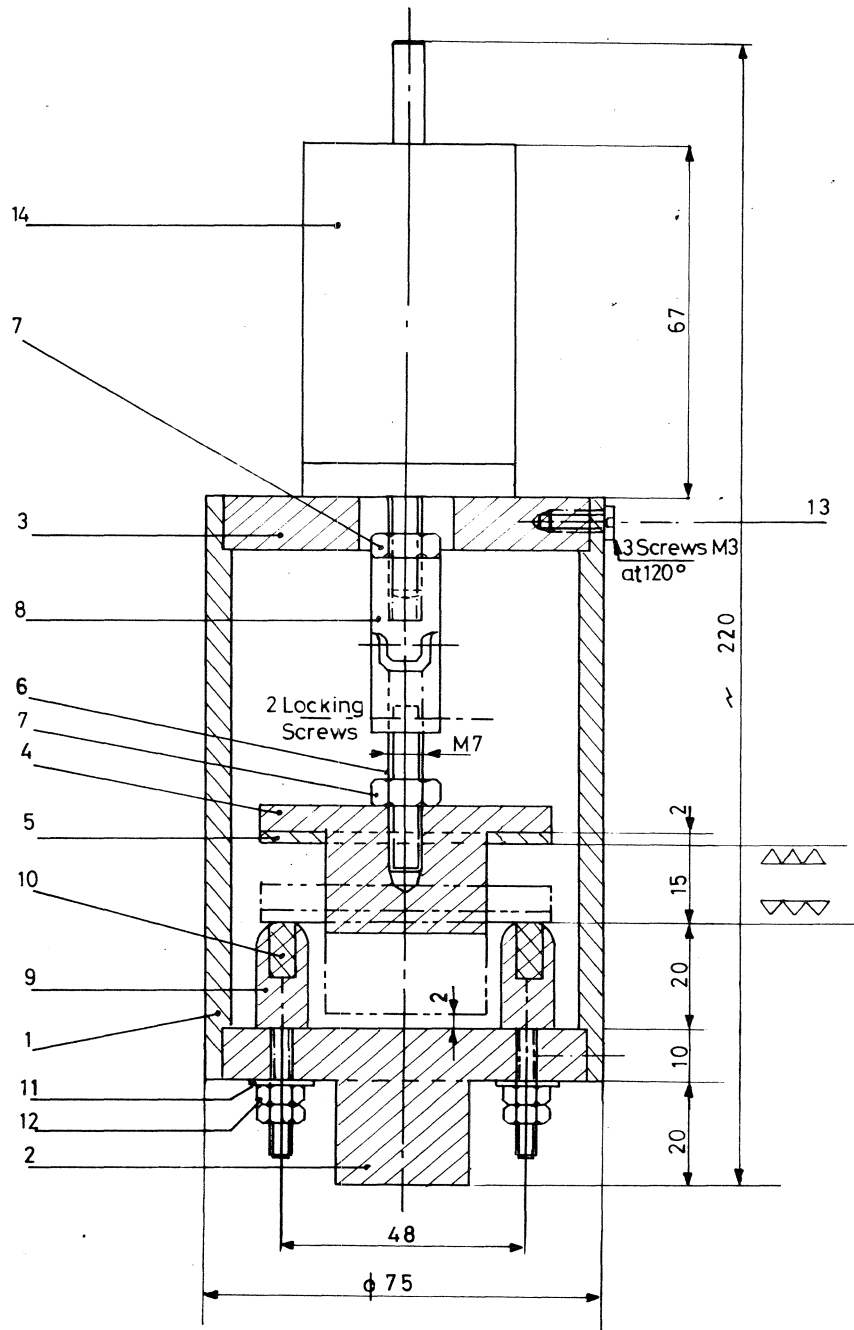

1	Solenoid	14		Harting Typ HM 41, 100% ED 24 V =
6	Screws M3 L = 10	13	Nylon	
4	Nuts M5	12	Brass	
2	Washers 5.3 x 12	11	Brass	
2	Rods $\varnothing 5L = 10$	10	Tungsten	Press fit into. item 9
2	Rods $\varnothing 10L = 45$	9	Brass	
1	Joint	8	Steel	
2	Nuts M7	7	Steel	
1	Threaded rod M7 L = 30	6	Steel	
1	Ring 55 x 32 th.2	5	Tungsten	Epoxy resin on item 4
1	Upper contact support	4	Perspex	
1	Lid $\varnothing 70$ thickness 10	3	Perspex	
1	Base $\varnothing 70$ thickness 30	2	Perspex	
1	Tube $\varnothing 75 \times 65 L = 110$	1	Perspex	

Nombre de pièces		Désignation		Pos.	Matière	Observations
III	II	I	Mod.	Date	Nom	Tolérances générales
			A			de à ±
			B			de à ±
			C			de à ±
Ensemble					S. Ensemble	Dessiné Contrôlé Vu
PULSED BEAM TRANSPORT					Echelle	Remplace
HIGH VOLTAGE SWITCH						Remplacé par
Dossier N.º	Dossier N.º	Dossier N.º	ORGANISATION EUROPÉENNE POUR LA RECHERCHE NUCLÉAIRE CERN EUROPEAN ORGANIZATION FOR NUCLEAR RESEARCH			DIVISION NPA 1211 GENÈVE 23
						224 - 325 - 3 A

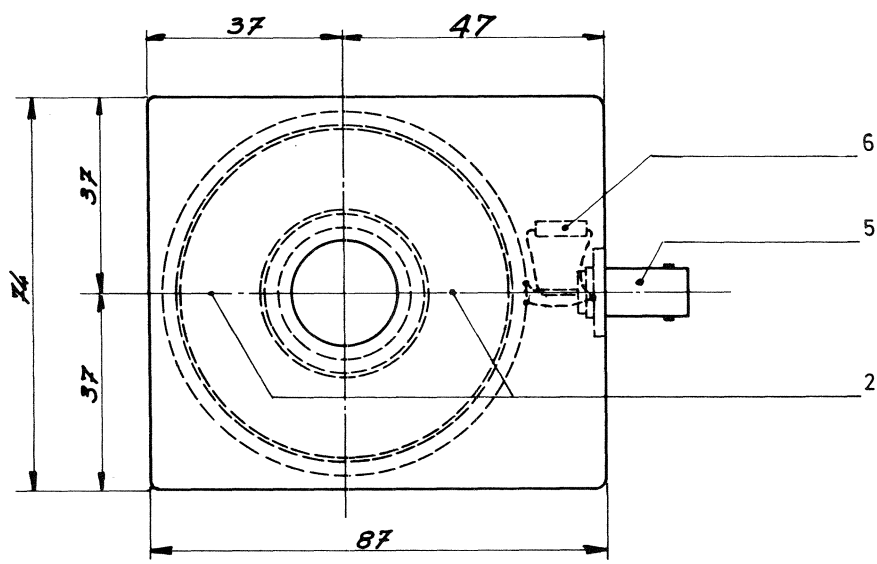
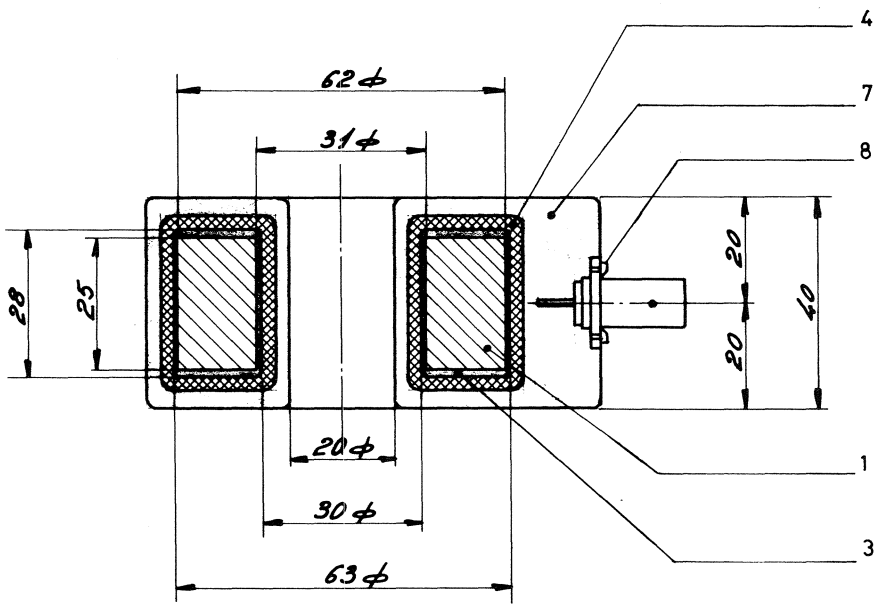

	4	screw M3 x 6	8	Steel	
	1	encapsulation	7	Epoxy resin	
	1	resistor	6		1Ω - 1W, Low inductance
	1	BNC - connector	5		
	1	secondary winding ø 0,8	4	enameled copper wire	300 turns in 3 tightly wound layers
	1	insulation	3	insulating material	
	2	gap thick 0,07	2	Mylar	
	1	core	1	Iron	grain oriented silicon iron

Nombre de pièces		Désignation		Pos.	Matière	Observations
III	II	I	Mod. Date Nom	Tolérances générales		
			A 5.69 J.P	de	à	±
			B	de	à	±
			C	de	à	±
Ensemble		S. Ensemble		Dessiné 5.11.68 J.P.		
Pulsed beam transport		Echelle 1:1		Contrôlé		
Current transformer				Vu		
ORGANISATION EUROPEENNE POUR LA RECHERCHE NUCLEAIRE		DIVISION NPA		Remplace		
CERN EUROPEAN ORGANIZATION FOR NUCLEAR RESEARCH		1211 GENÈVE 23		Remplacé par		
				224-326-3 A		

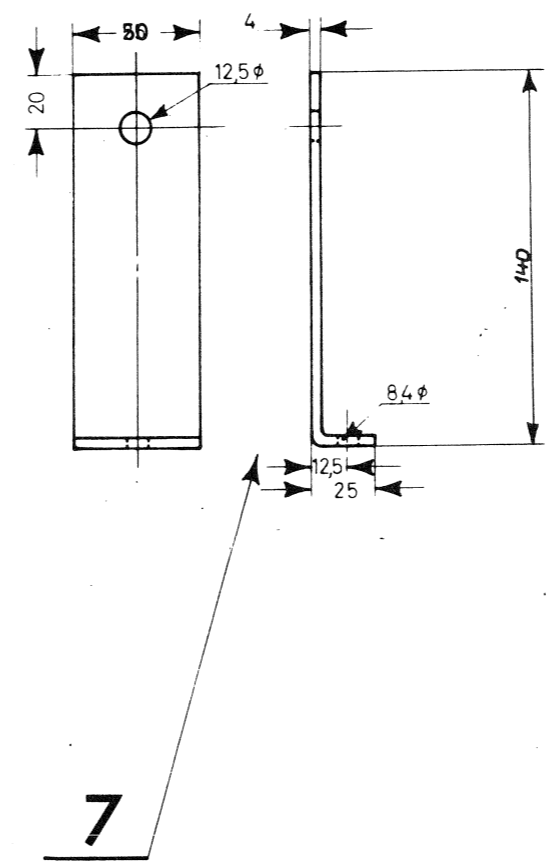
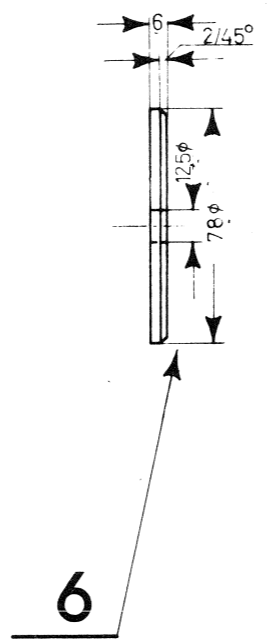
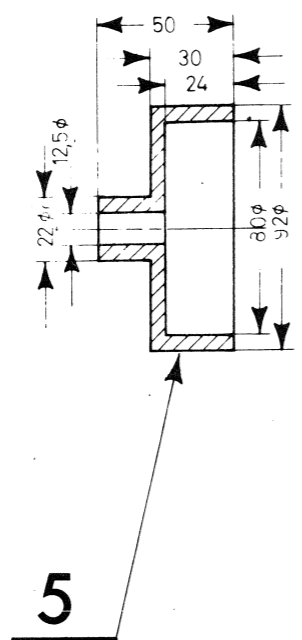
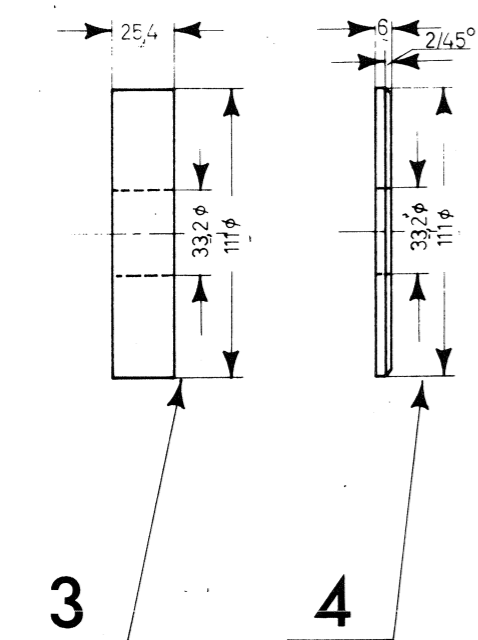
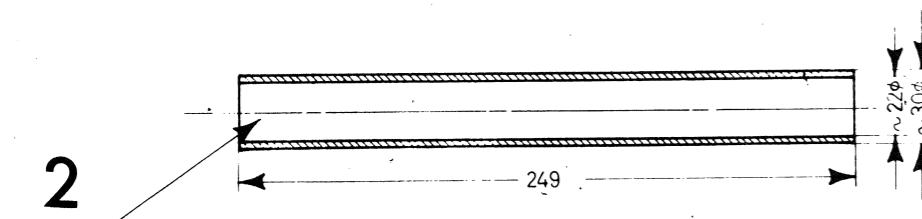
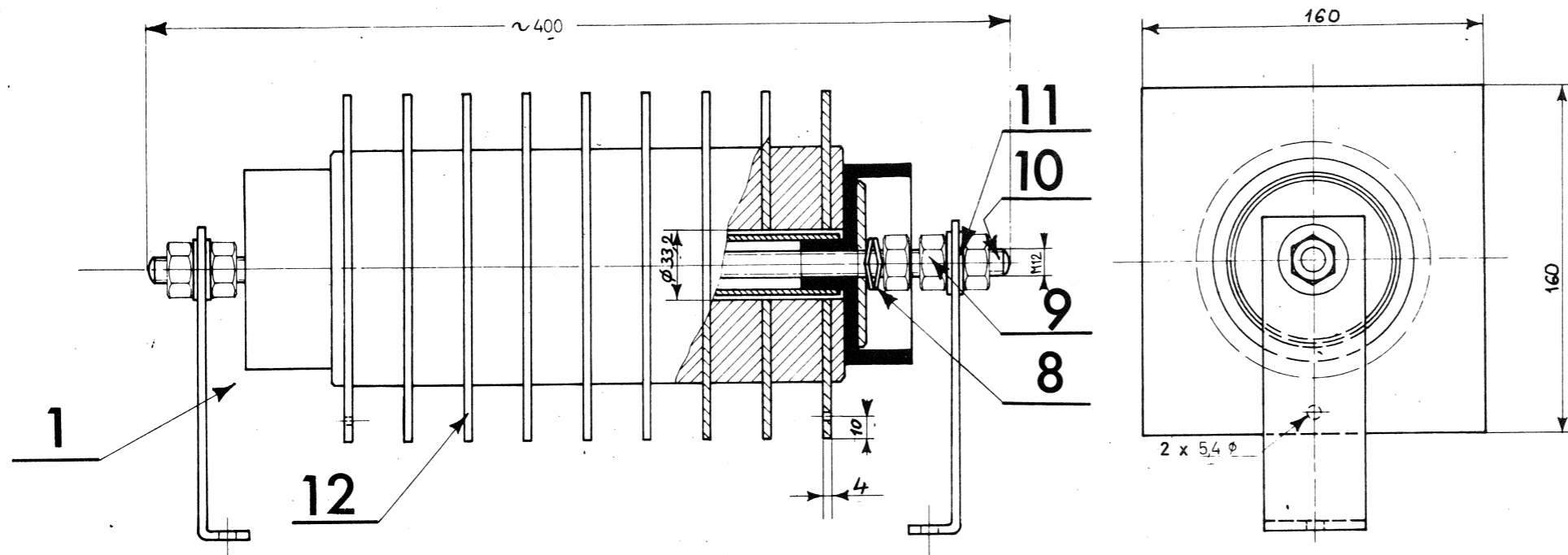

Pos.	Matière	Observations
9	Cooling Fin	12 Aluminium
4	Washer	11 Brass
1	Clamping bolt	10 Brass
5	Nut M12	9 Brass
2	Schnorr Washer	8 -
2	Fixing bracket	7 Brass
2	Disc	6 Brass
2	Insulator	5 Polyet. or equiv.
2	Disc	4 Brass
8	Resistor	3 Morganite Type Y763 150Ω
1	Insulating tube	2 Tufnol or equiv
1	Assembly	1 -

Mod.	Date	Nom	Tolérances générales	Observations		
A			de à ±			
B			de à ±			
C			de à ±			
Ensemble			S. Ensemble	Dessiné		
PULSED BEAM TRANSPORT			Echelle	Contrôlé	3.3.69	Devo ulmy
AUXILIARY DISCHARGE			1/2	Remplace		
RESISTOR CARBON TYPE				Remplacé par		
ORGANISATION EUROPÉENNE POUR LA RECHERCHE NUCLÉAIRE DIVISION				224.457.2		
CERN EUROPEAN ORGANIZATION FOR NUCLEAR RESEARCH NPA				1211 GENÈVE 23		

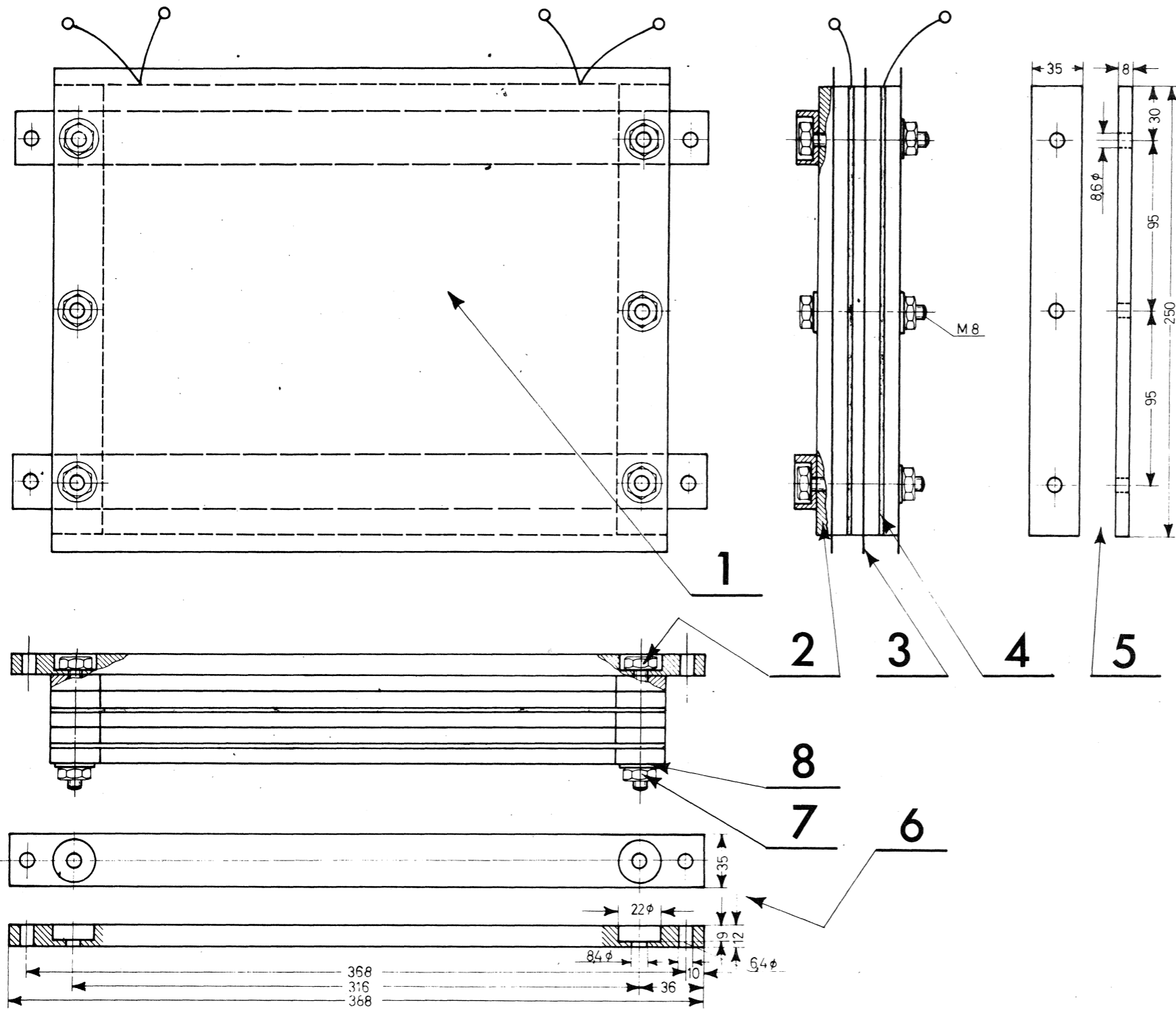

Nombre de pièces	Désignation	Pos.	Matière	Observations
		11		
		10		
		9		
6	Washer	8	Nylon	or equiv.
6	Nut	7	Nylon	or equiv.
2	Support frame strip	6	SRBF	
10	Support frame strip	5	SRBF	
2	Resistor	4	Schniewindt resistor Type DMC 0,35g 560Ω	
3	Insulator	3	Mylar	357 x 268 x 0,35
6	Bolt	2	Nylon	or equiv.
1	Assembly	1	—	

Mod.	Date	Nom	Tolérances générales	
A			de	à ±
B			de	à ±
C			de	à ±

Ensemble		S. Ensemble		Dessiné	
PULSED BEAM TRANSPORT				Contrôlé	3.3.69
AUXILIARY DISCHARGE RESISTOR WIRE TYPE				Vu	Deoulay
				Echelle	
				1/2	
				Remplace	
				Remplacé par	

Dossier N°	Dossier N°	Dossier N°	ORGANISATION EUROPEENNE POUR LA RECHERCHE NUCLEAIRE CERN EUROPEAN ORGANIZATION FOR NUCLEAR RESEARCH	DIVISION NPA	224.456.2
			1211 GENEVE 23		

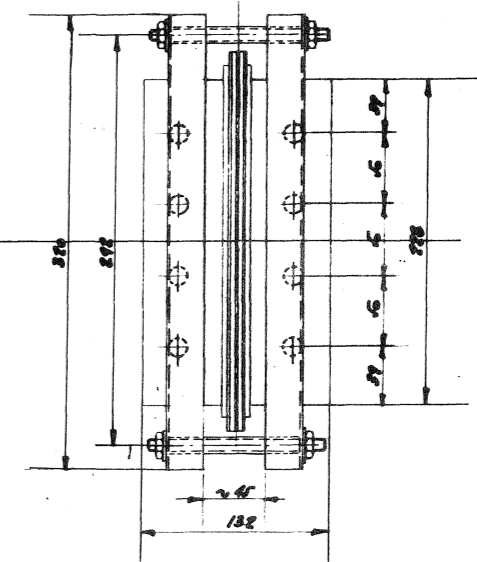
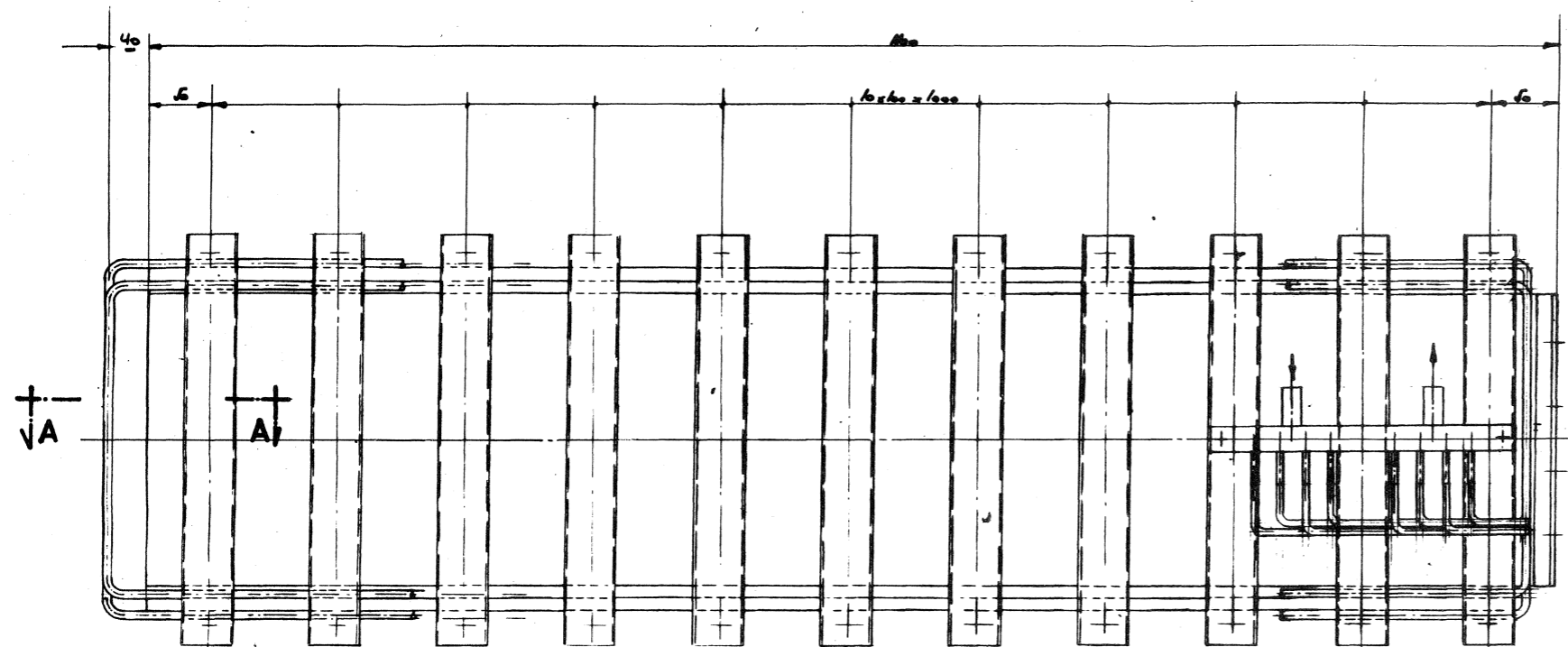

SCHEMA DE CONNEXION D'EAU

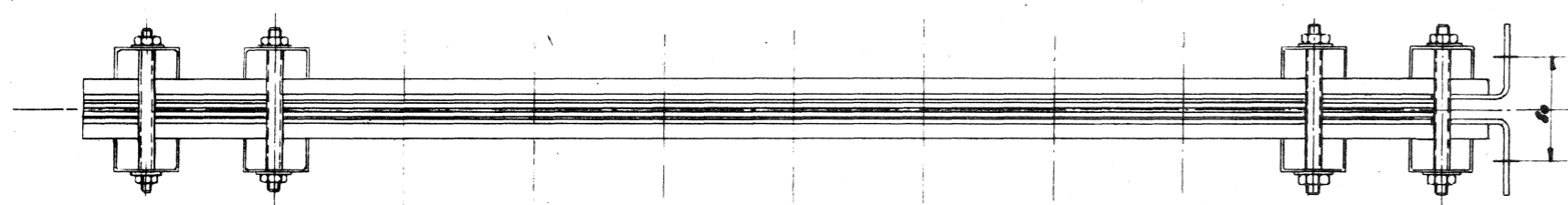
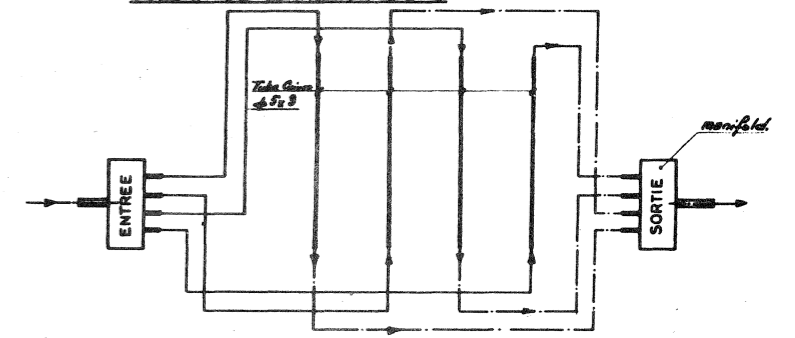

MANIFOLD

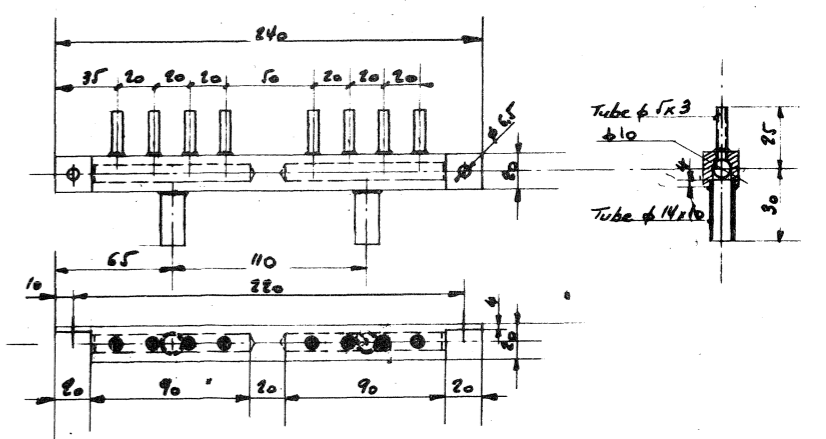

COUPE A-A

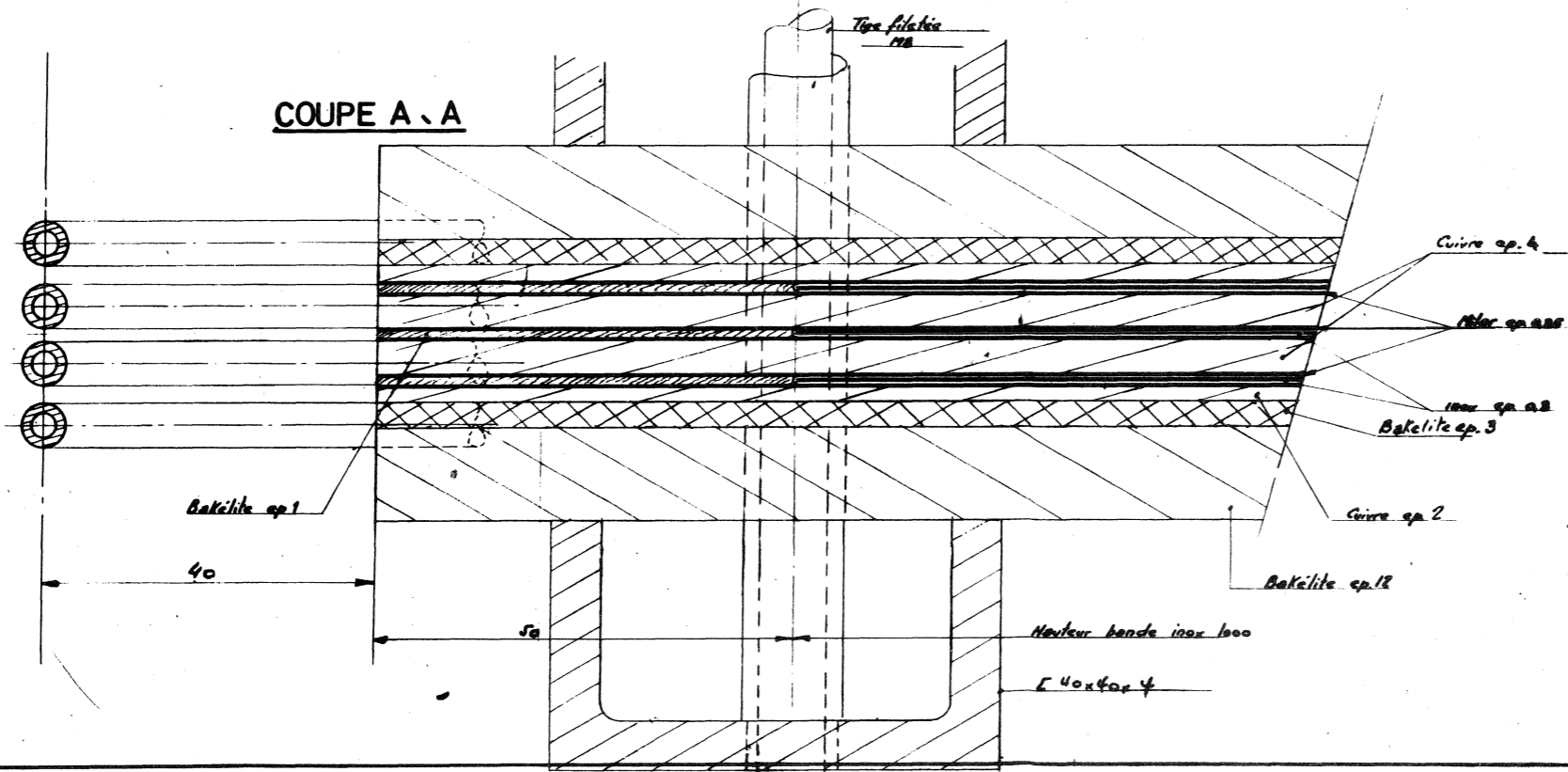

Nombre de pièces		Désignation		Pos.	Matière	Observations
III	II	Mod.	Date	Nom	Tolérances générales	
		A	3.3.66	<i>Wipac</i>	de	à ±
		B			de	à ±
		C			de	à ±
Ensemble		S. Ensemble		Dessiné		<i>Wipac</i> 17.2.66
PULSED BEAM TRANSPORT				Contrôle		Vu
CROW - BAR RESISTOR				Echelle		1/25
				Remplace		25/1
				Remplacé par		
ORGANISATION EUROPEENNE POUR LA RECHERCHE NUCLEAIRE		DIVISION		NPA		224.448.3
CERN EUROPEAN ORGANIZATION FOR NUCLEAR RESEARCH		1211 GENÈVE 23				

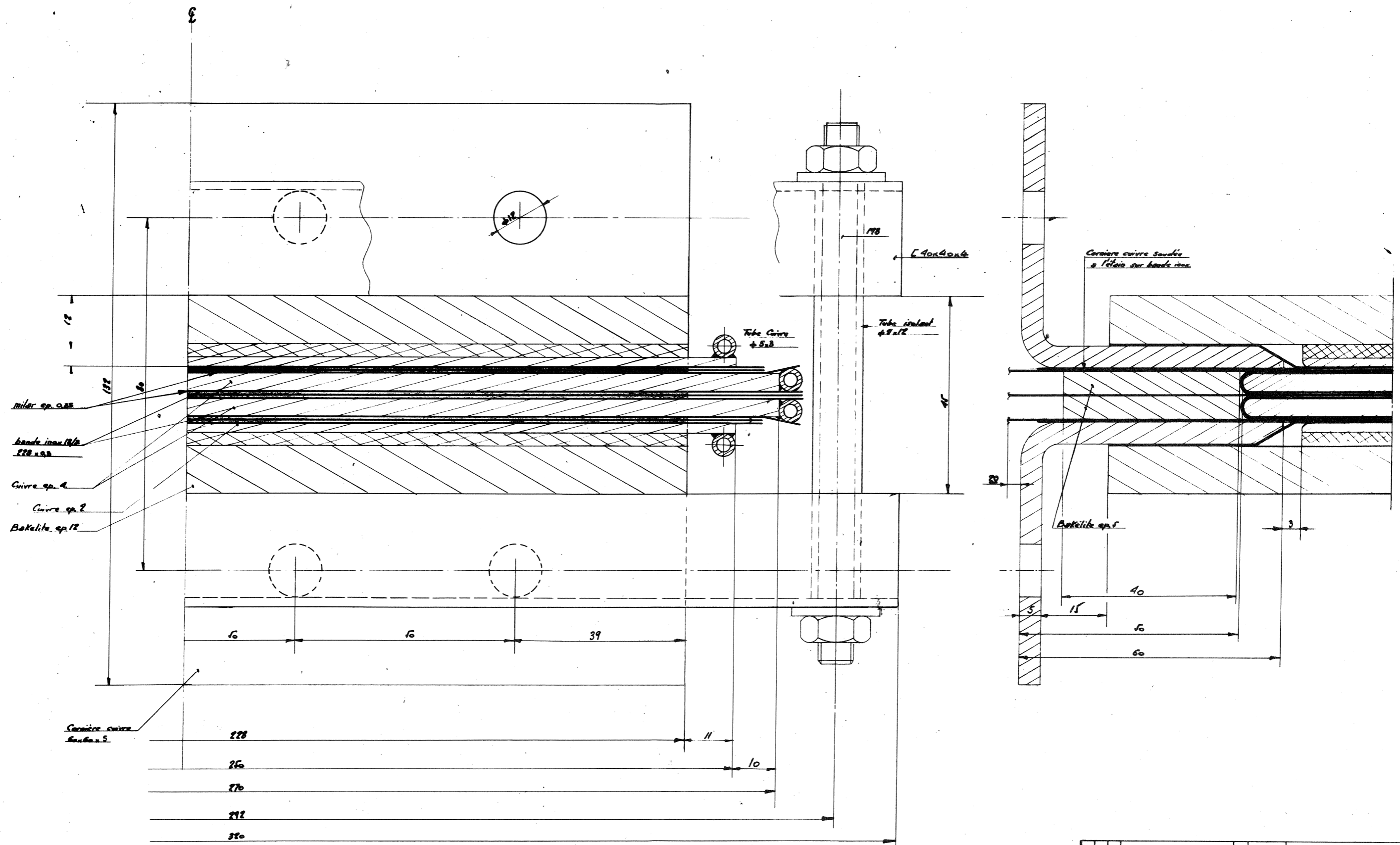

N° de pièce		Désignation	Pos.	Matière	Observations		
III	II	I	Med.	Date	Nom	Tolérances générales	
			A	2.3.66		de 0 ±	
			B			de 0 ±	
			C			de 0 ±	
Ensemble		S. Ensemble		Dessiné		7/11/66	
Ensemble		S. Ensemble		Contrôle		Vs	
Ensemble		S. Ensemble		Remplace		Remplacé par	
Ensemble		S. Ensemble		Echelle		2,5/1	
Ensemble		S. Ensemble		Remplacé par			
Dossier N°.	Dossier N°.	ORGANISATION EUROPÉENNE POUR LA RECHERCHE NUCLÉAIRE		DIVISION		NPA	
		CERN EUROPEAN ORGANIZATION FOR NUCLEAR RESEARCH		1211 GENEVE 23		224.449.3	

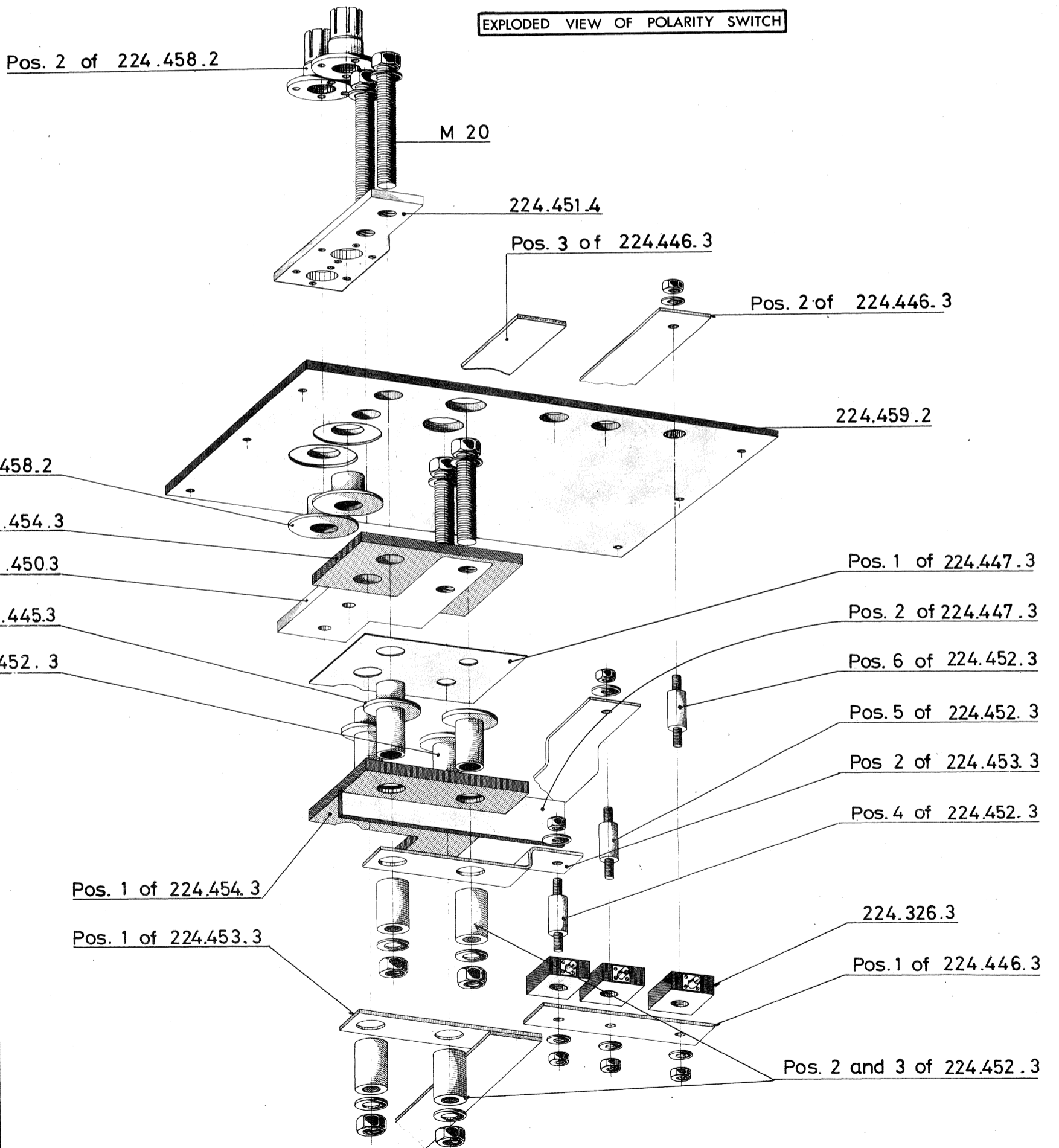
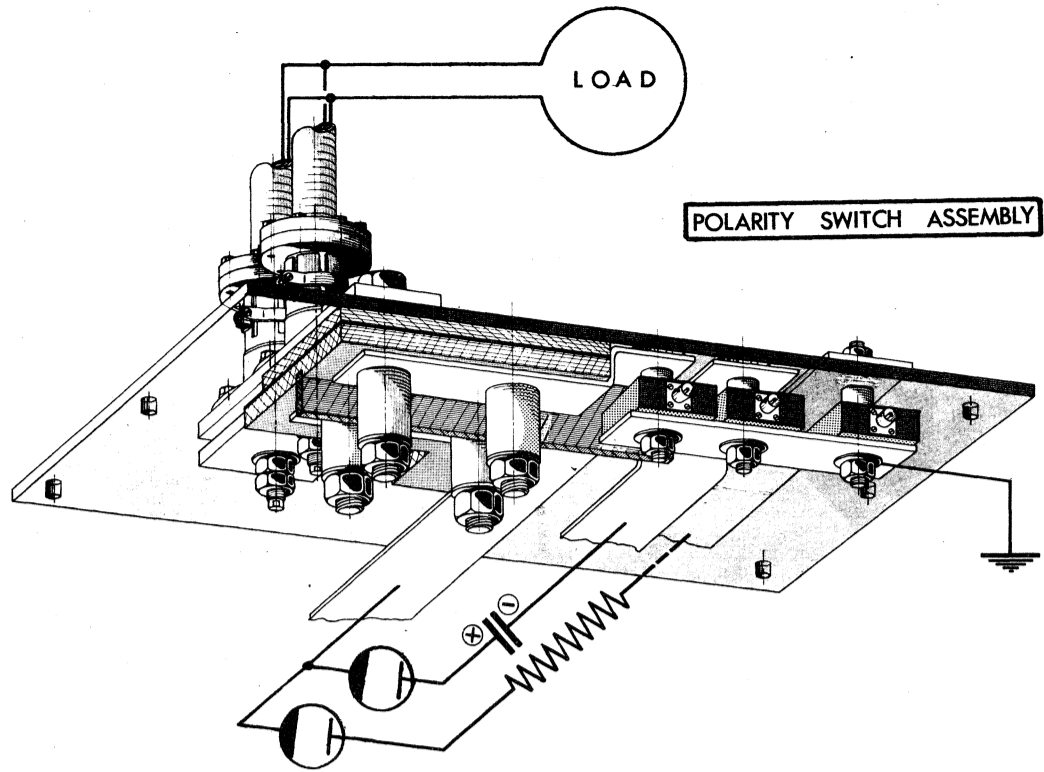

POLARITY SWITCH FOR 12kV
DISCHARGE CIRCUIT

CERN NPA
224.455.3

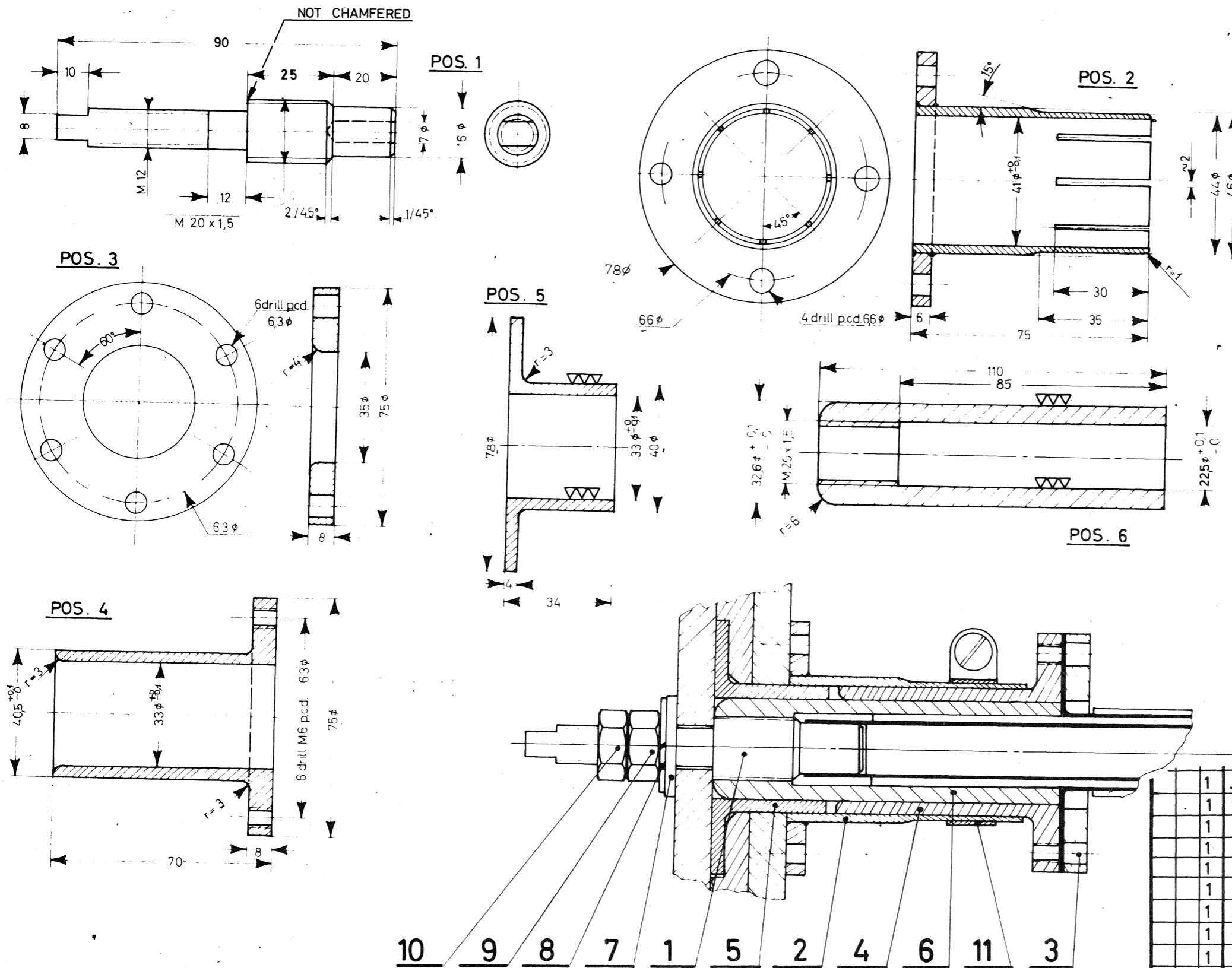

1	Jubilee clip	11	
1	Lock nut	10	M12 VSM 12698
1	Nut	9	M12 VSM 12700
1	Lock washer	8	Ø12 VSM 12740
1	Flat washer	7	Ø13·20 VSM12722
1	Insulator	6	POLYPHENYLENOXIDE (PPO)
1	Insulator	5	" "
1	Outer conductor body	4	Brass With silver layer 10µ
1	Clamping ring	3	Brass " " " "
1	Connector fixing clamp	2	Brass " " " "
1	Center pin	1	Brass " " " "
Nombre de pièces		Désignation	Pos. Matière Observations

III	II	I	Mod.	Date	Nom	Tolérances générales		
			A			de	à	±
			B			de	à	±
			C			de	à	±
			Ensemble		S. Ensemble		Dessiné	
			PULSED BEAM TRANSPORT		Echelle		Contrôlé	
			HIGH VOLTAGE COAXIAL CONNECTOR		1/1		Vu	
			ORGANISATION EUROPÉENNE POUR LA RECHERCHE NUCLÉAIRE DIVISION CERN EUROPEAN ORGANIZATION FOR NUCLEAR RESEARCH NPA				Remplace	
							Remplacé par	
Dossier N°	Dossier N°	Dossier N°					224.458.2	
1211 GENÈVE 23								

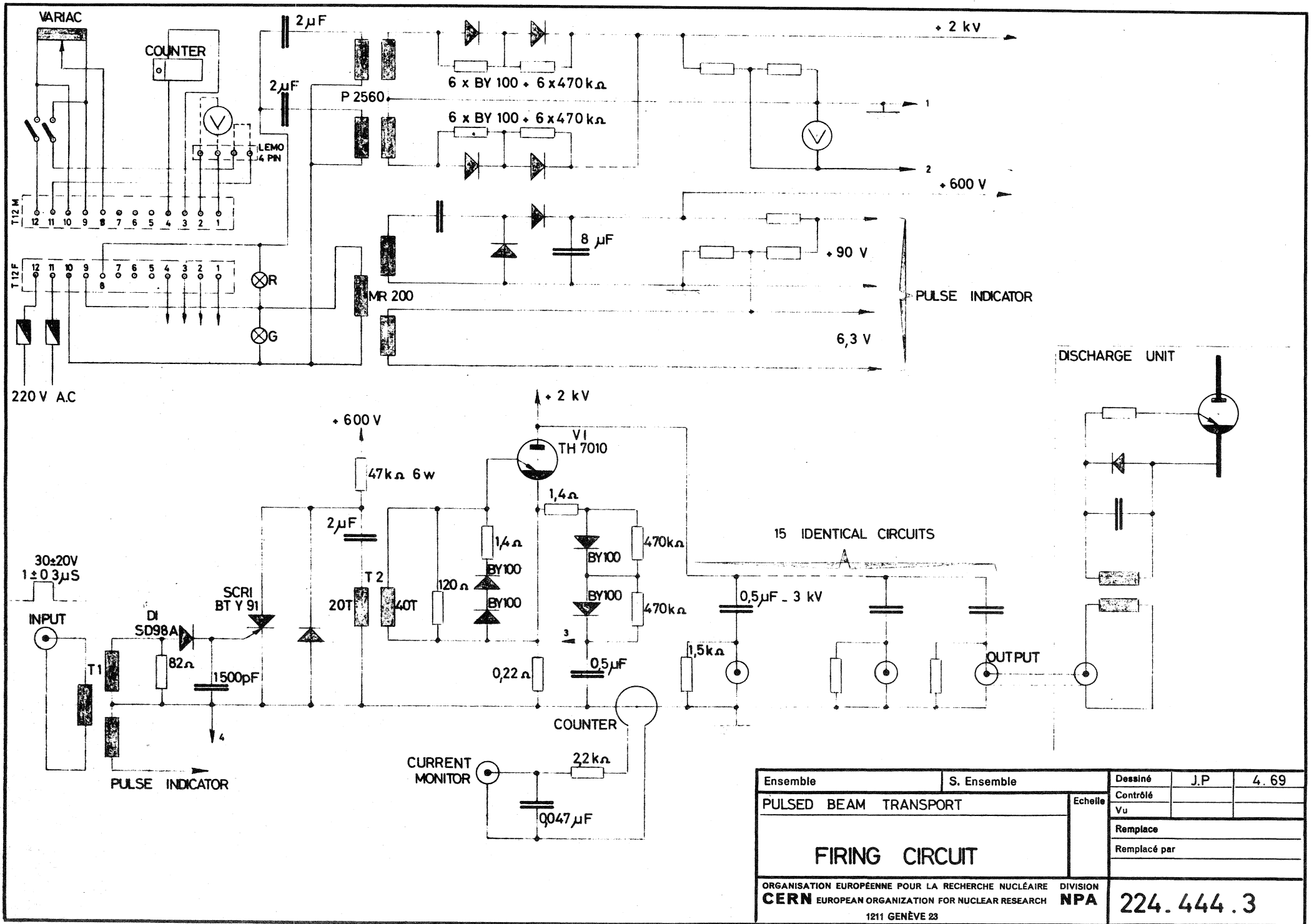

Ensemble	S. Ensemble	Dessiné	J.P	4.69
PULSED BEAM TRANSPORT		Contrôlé		
FIRING CIRCUIT		Echelle		
		Remplace		
ORGANISATION EUROPÉENNE POUR LA RECHERCHE NUCLÉAIRE CERN EUROPEAN ORGANIZATION FOR NUCLEAR RESEARCH		Remplacé par		
				224.444.3
1211 GENÈVE 23				

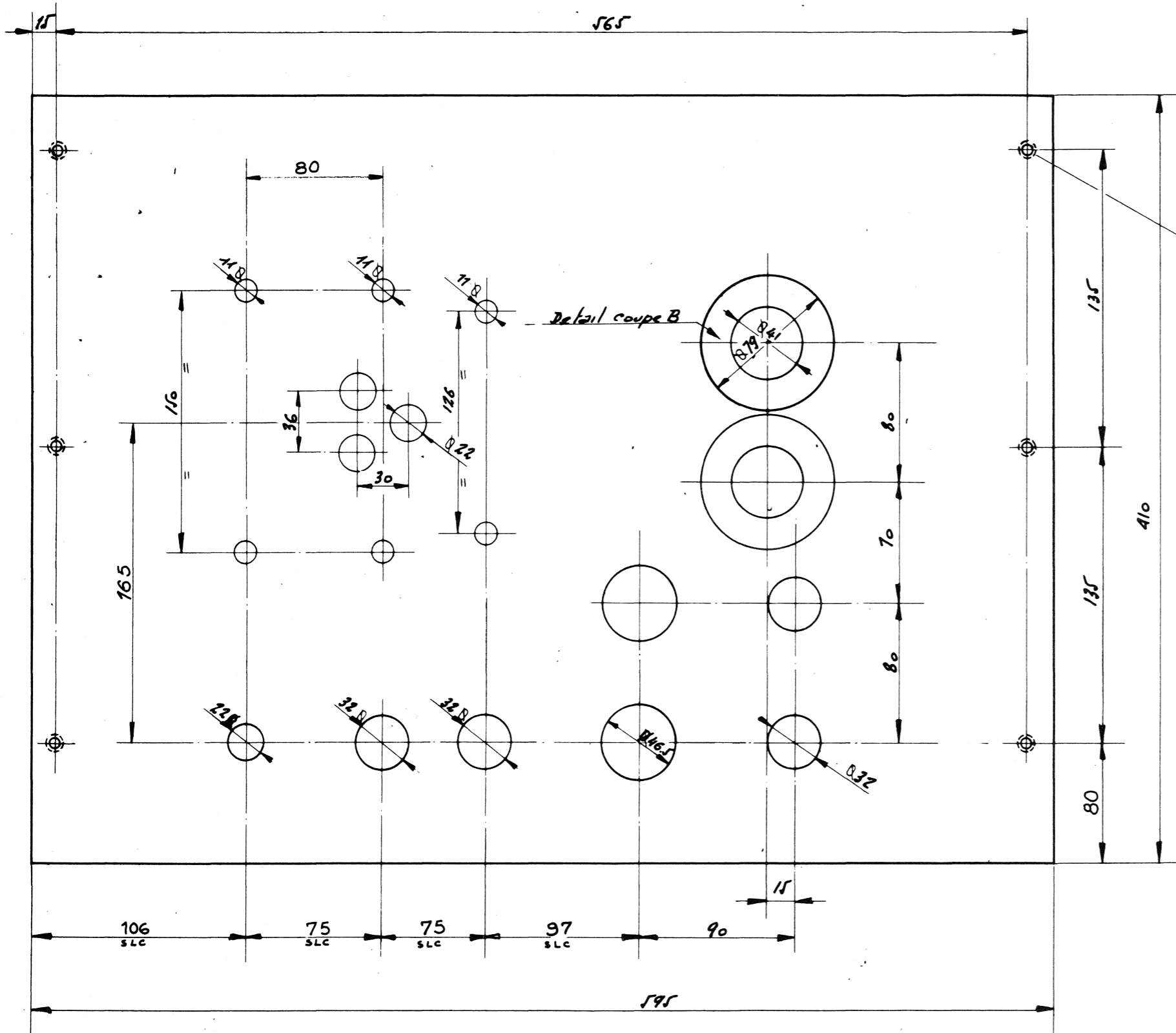

Détail en coupe "A"

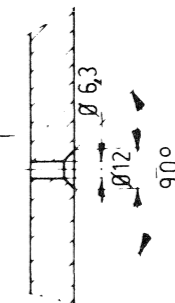

Détail en coupe "B"

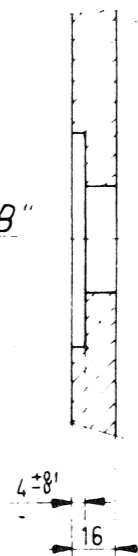

1		Plaque 595 x 440 x 16		1	Résofil		
Nombre de pièces		Désignation		Pos.	Matière	Observations	
III	II	I	Mod. Date Nom	Tolérances générales			
			A	de	à	±	
			B	de	à	±	
			C	de	à	±	
Ensemble		S. Ensemble		Dessiné		11.3.69	Demoulaye
PULSED BEAM TRANSPORT		Echelle		Contrôle			
INSULATION PLATE		1/2		Vu			
ORGANISATION EUROPÉENNE POUR LA RECHERCHE NUCLÉAIRE DIVISION		CERN EUROPEAN ORGANIZATION FOR NUCLEAR RESEARCH NPA		Remplace			
1211 GENÈVE 23		224.459.2		Remplacé par			

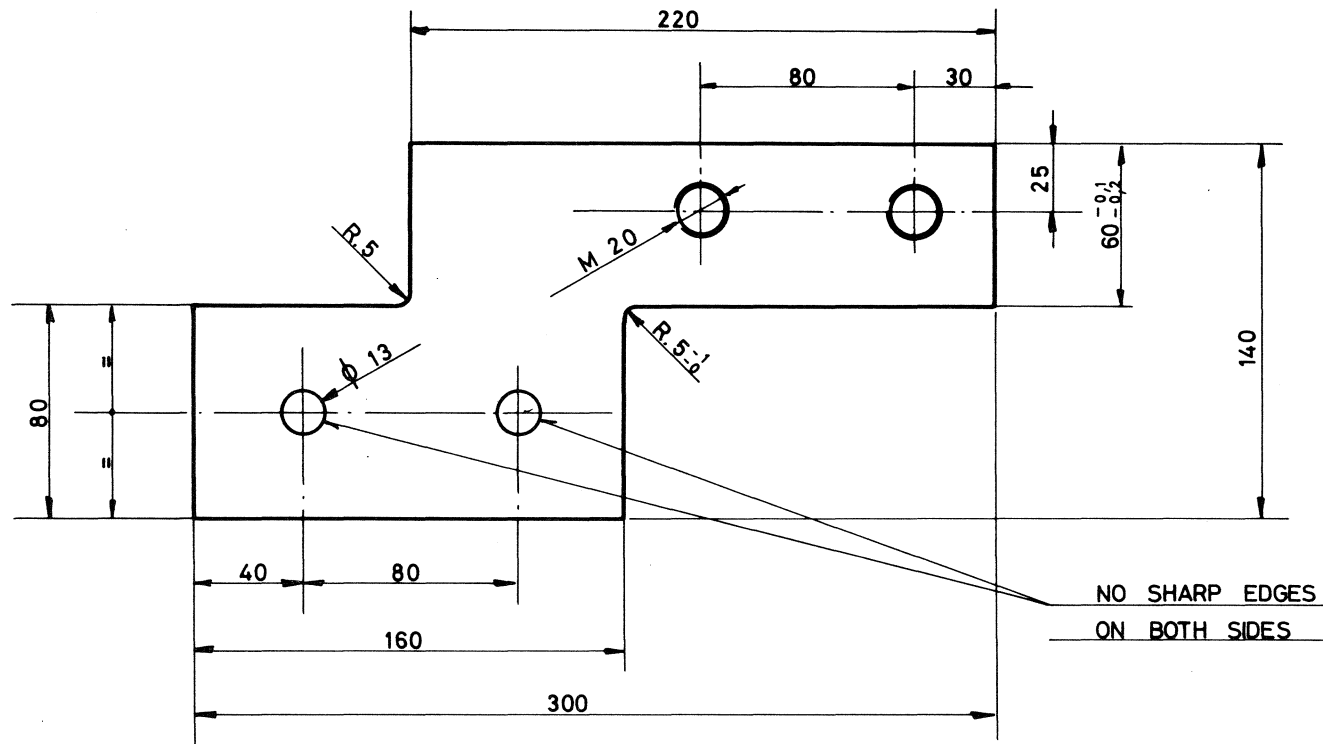

			1	300 x 140 Thickness 12		ANTICO		
Nombre de pièces		Désignation			Pos.	Matière		Observations
III	II	I	Mod.	Date	Nom	Tolérances générales		
			A			de	à	±
			B			de	à	±
			C			de	à	±
Ensemble		S. Ensemble			Dessiné		J.P.	8.69
PULSED BEAM TRANSPORT		Echelle		Contrôlé		Vu		
CONNEXION		1/2		Remplace		Remplacé par		
Dossier N°		Dossier N°		Dossier N° FOR ONE RACK		ORGANISATION EUROPÉENNE POUR LA RECHERCHE NUCLÉAIRE DIVISION		
						CERN EUROPEAN ORGANIZATION FOR NUCLEAR RESEARCH NPA		224.450.3
						1211 GENÈVE 23		

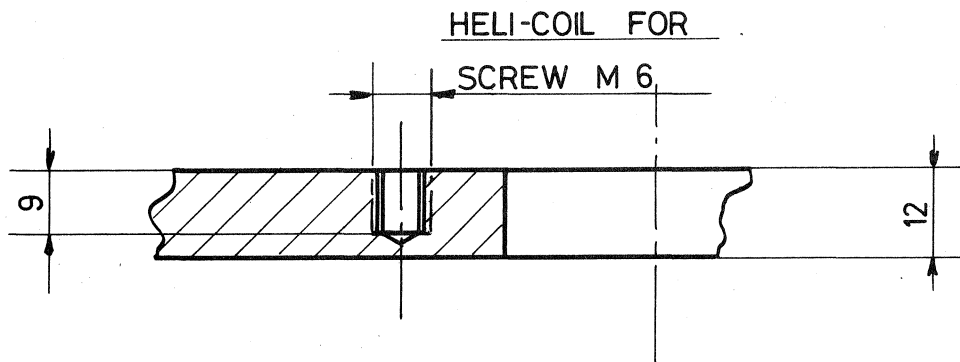
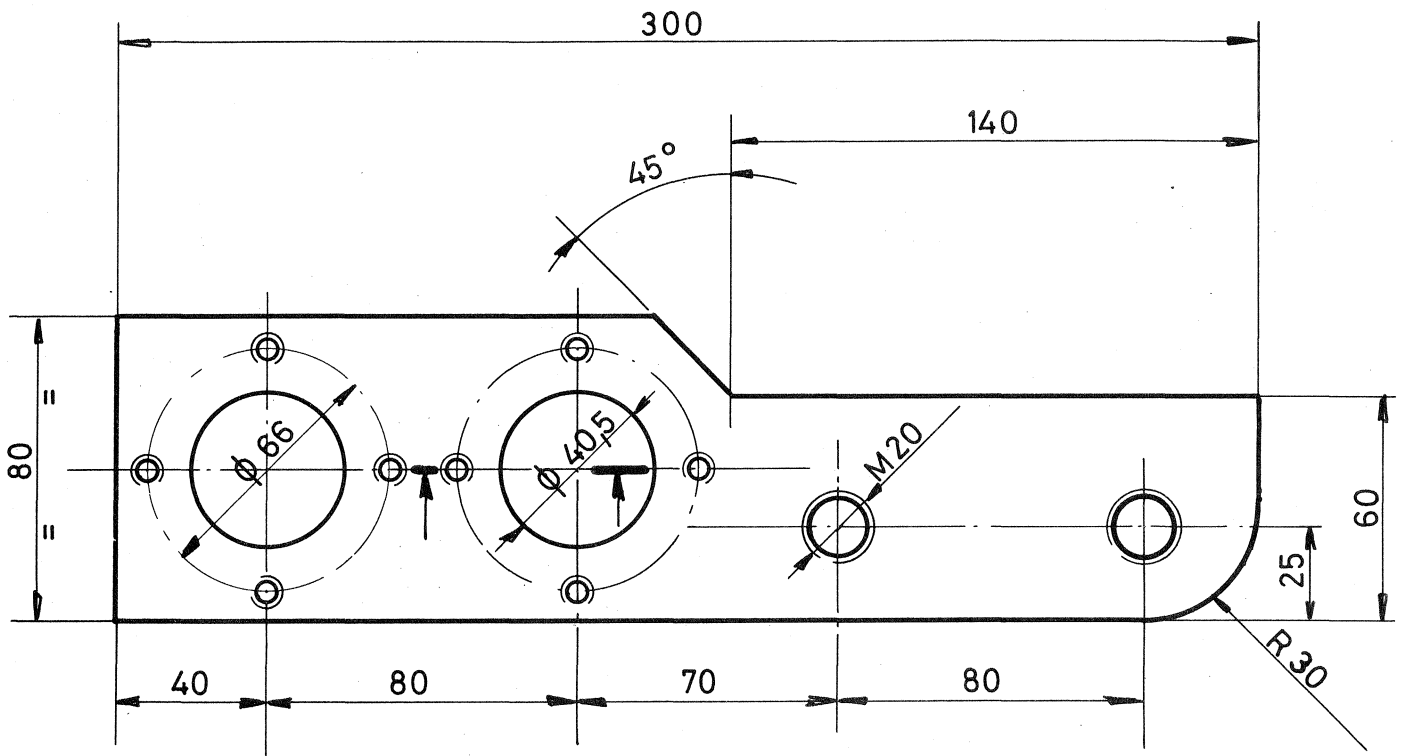

	1	300x80 Thickness 12	ANTICO		
Nombre de pièces		Désignation	Pos.	Matière	Observations
III	II	I	Tolérances générales		
		Mod.	Date	Nom	
		A			de à ±
		B			de à ±
		C			de à ±
		Ensemble		S. Ensemble	
		PULSED BEAM TRANSPORT			Echelle
		CONNEXION			1/2
					1/1
Dossier N ^o	Dossier N ^o	ORGANISATION EUROPÉENNE POUR LA RECHERCHE NUCLÉAIRE			DIVISION
		CERN EUROPEAN ORGANIZATION FOR NUCLEAR RESEARCH			NPA
		1211 GENÈVE 23			224.451.4
				Dessiné	J.P 8.69
				Contrôlé	
				Vu	
				Remplace	
				Remplacé par	

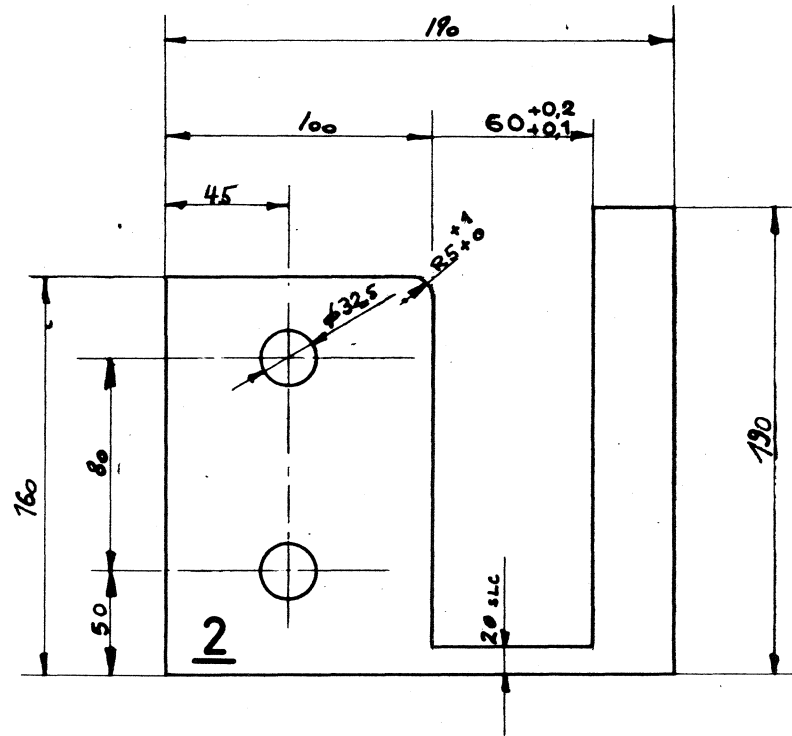
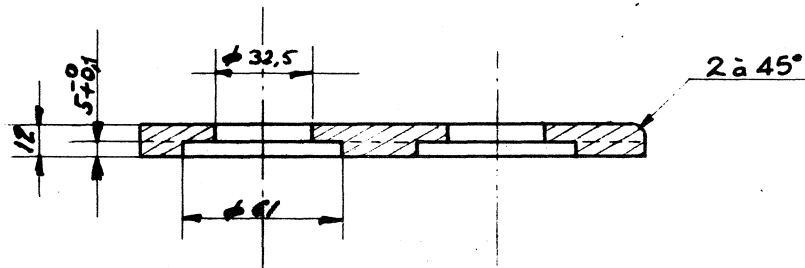
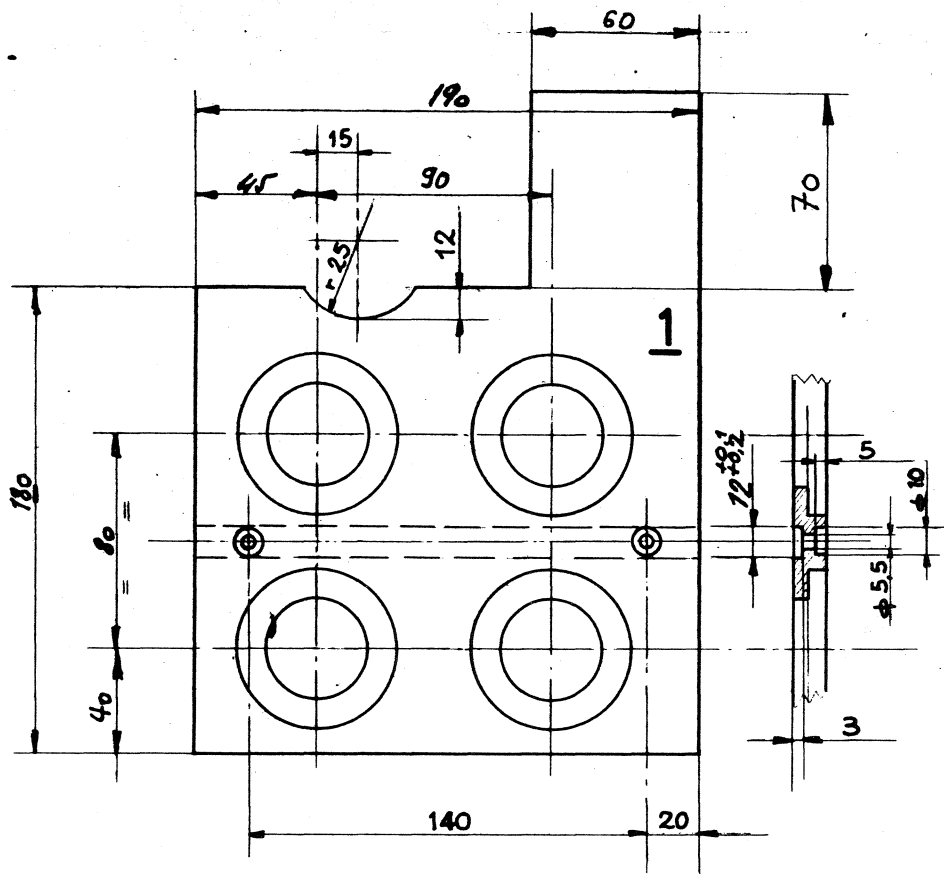

		1	Plaque 190 x 190 ep. 12	2	Resofil	
		1	plaque 190 x 250 ep. 12	1	Resofil	
Nombre de pièces		Désignation		Pos.	Matériau	Observations
III	II	I	Mod.	Date	(Nom)	Tolérances générales
			A			de à ±
			B			de à ±
			C			de à ±
			Ensemble		S. Ensemble	Desiné <i>W. H. F. F. 22.8.66</i>
			PULSED BEAM TRANSPORT		Echelle	Contrôlé
			INSULATING PIECE		1/2	Vu
			ORGANISATION EUROPÉENNE POUR LA RECHERCHE NUCLÉAIRE DIVISION CERN EUROPEAN ORGANIZATION FOR NUCLEAR RESEARCH NPA			Remplace
			1211 GENEVE 23			Remplacé par
						224.454.3

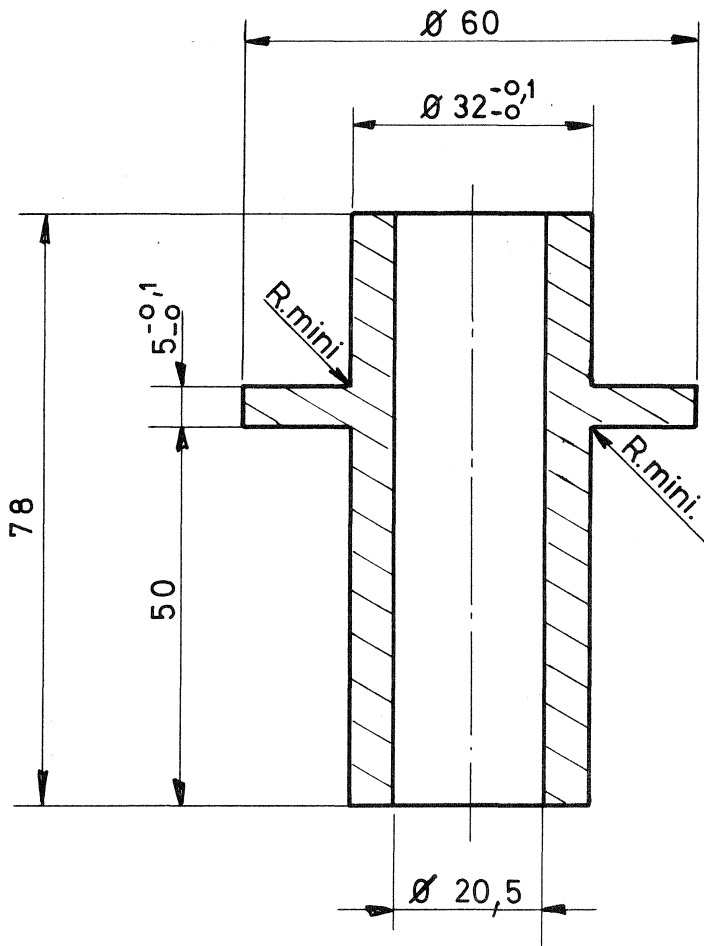

		2	ROND Ø 60 long. 80		Polyethyl.						
Nombre de pièces			Désignation		Pos.	Matière		Observations			
III	II	I	Mod.	Date	Nom		Tolérances générales				
			A				de	à ±			
			B				de	à ±			
			C				de	à ±			
Dossier N° Dossier N° Dossier N° p.r 1 rack			Ensemble		S. Ensemble		Dessiné	J.P	7. 69		
			PULSED BEAM TRANSPORT					Echelle 1/1	Contrôlé		
			INSULATOR						Vu		
								Remplacé par			
			ORGANISATION EUROPÉENNE POUR LA RECHERCHE NUCLÉAIRE CERN EUROPEAN ORGANIZATION FOR NUCLEAR RESEARCH				DIVISION NPA		224.445 _ 4		
1211 GENÈVE 23											

1

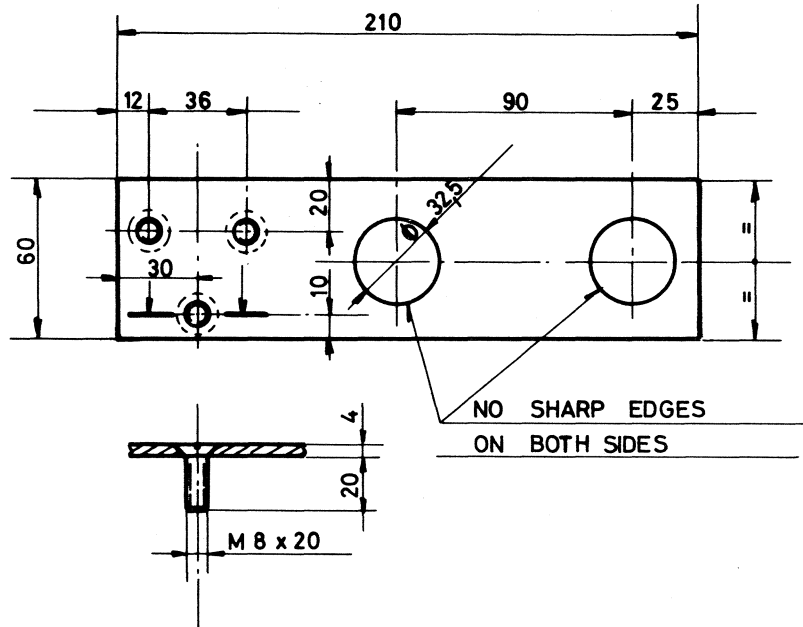

2

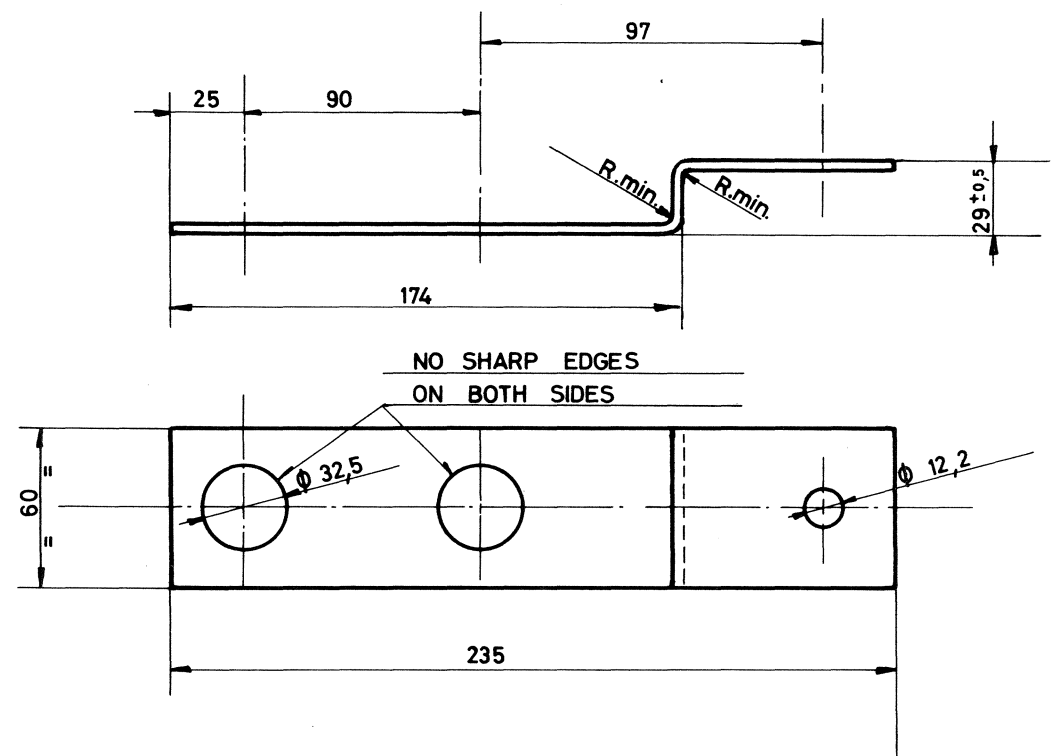

		1	60 x 4 Length 260	2	COPPER	
		1	60 x 4 Length 210	1	COPPER	
Nombre de pièces			Désignation	Pos.	Matière	Observations
III	II	I	Mod.	Date	Nom	Tolérances générales
			A			de à ±
			B			de à ±
			C			de à ±
Ensemble			S. Ensemble			Dessiné J.P. 8.69 Contrôlé Vu Remplacé Remplacé par
PULSED BEAM TRANSPORT					Echelle	
CONNEXIONS					1/2	
ORGANISATION EUROPÉENNE POUR LA RECHERCHE NUCLÉAIRE DIVISION						
CERN EUROPEAN ORGANIZATION FOR NUCLEAR RESEARCH NPA						224.453-3
1211 GENEVE 23						

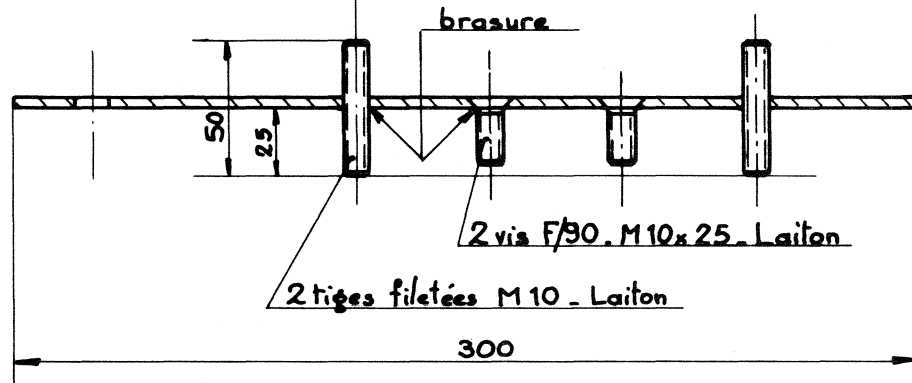
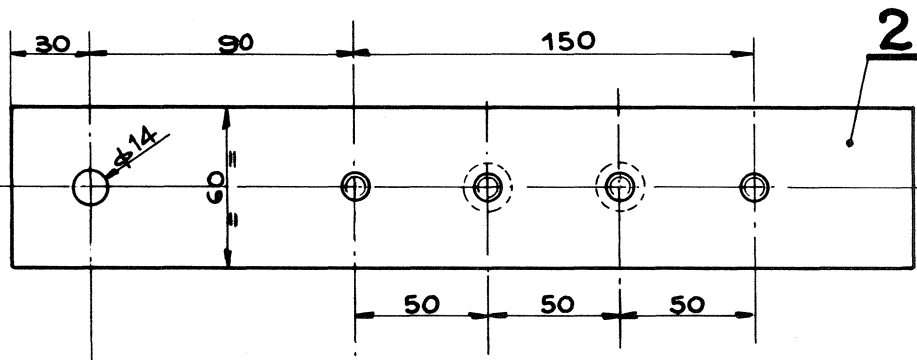
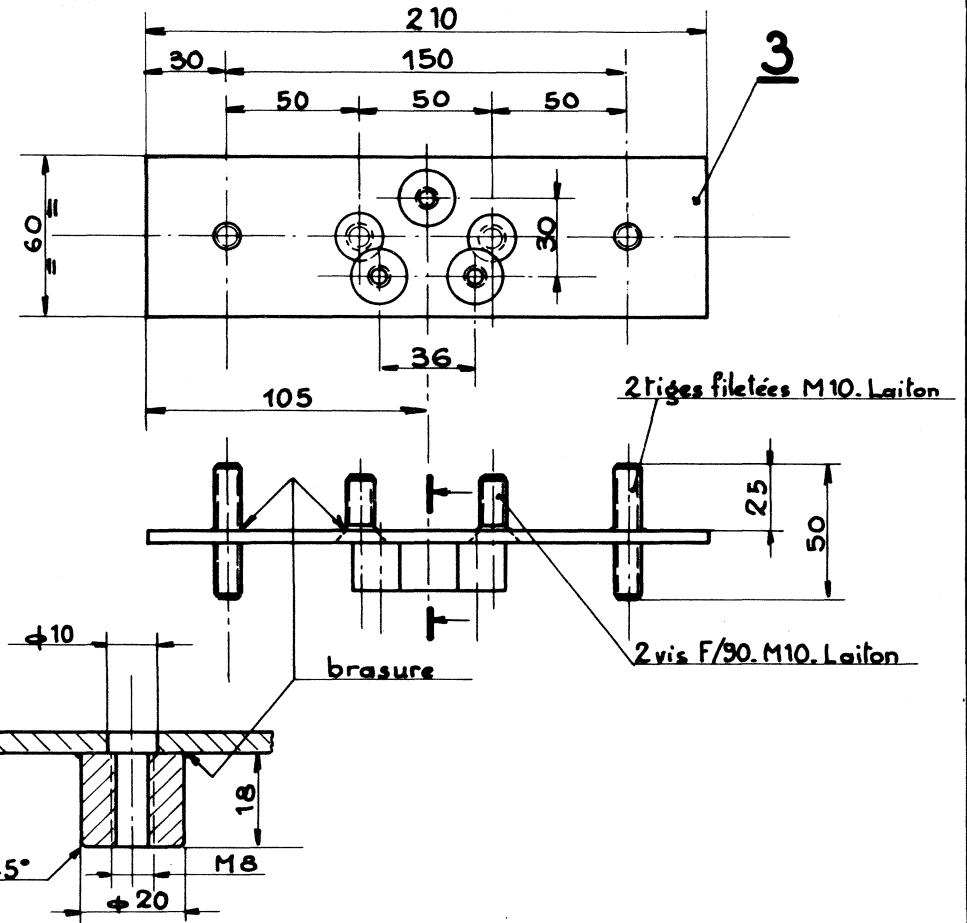
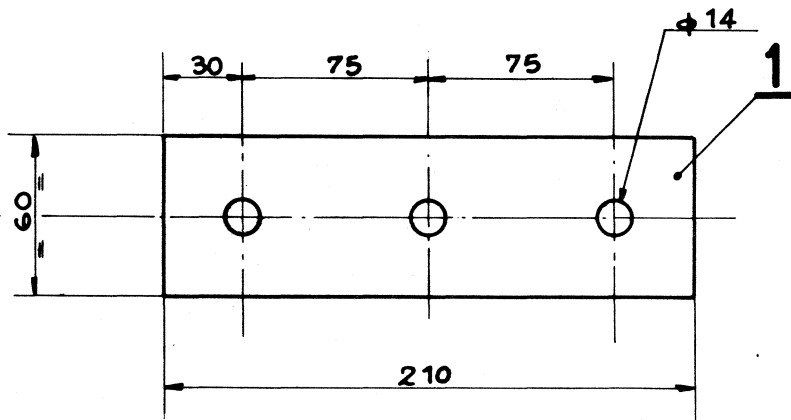

1	Plaque 210x60x4	3	Cuivre	Visserie brasée
1	Plaque 300x60x4	2	Cuivre	Visserie brasée
1	Plaque 210x60x4	1	Cuivre	
Nombre de pièces	Désignation	Pos.	Matière	Observations

Dossier N° Dossier N° Dossier N° Pour 1 rak	III	II	I	Mod.	Date	Nom	Tolérances générales			
				A			de	à	±	
				B			de	à	±	
				C			de	à	±	
			Ensemble		S. Ensemble			Dessiné	J.P	4.69
			PULSED BEAM TRANSPORT					Echelle	Contrôlé	
			CONNEXIONS					1/2	Vu	
									Remplace	
			ORGANISATION EUROPÉENNE POUR LA RECHERCHE NUCLÉAIRE DIVISION CERN EUROPEAN ORGANIZATION FOR NUCLEAR RESEARCH NPA					Remplacé par		
								224.446.3		
			1211 GENÈVE 23							

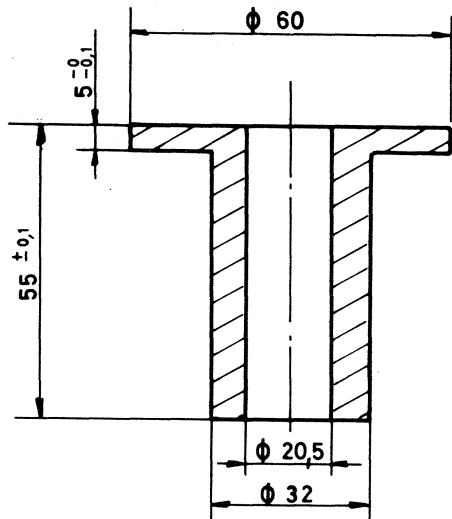

1

NO SHARP EDGES

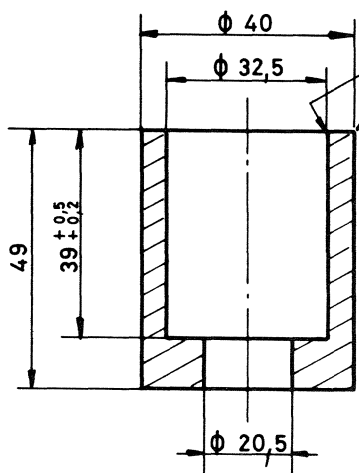
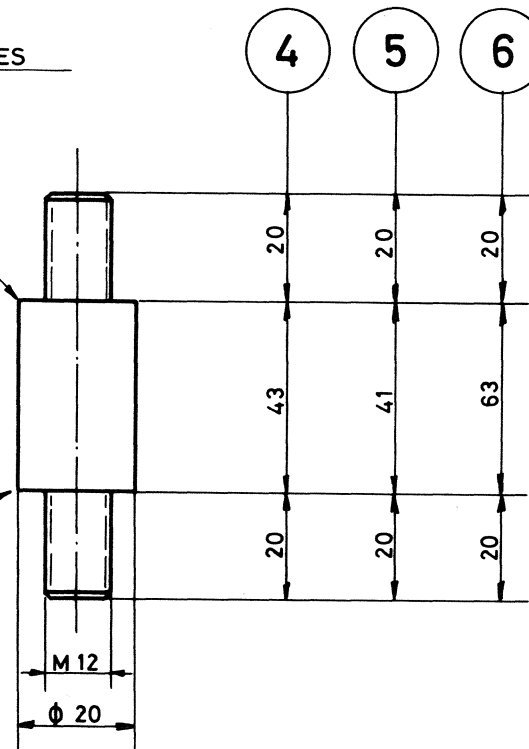

NO SHARP EDGES
ON POS. 3

2

3

	1	∅ 20	Length	103	6	BRASS	
	1	∅ 20	Length	81	5	BRASS	
	1	∅ 20	Length	83	4	BRASS	
	2	∅ 40	Length	50	3	BRASS	with silver layer 10μ
	2	∅ 40	Length	50	2	Polyethylen	
	2	∅ 60	Length	55	1	Polyethylen	
	Nombre de pièces		Désignation		Pos.	Matière	Observations

Dossier N°	II	I	Mod.	Date	Nom	Tolérances générales			
			A			de	à	±	
			B			de	à	±	
			C			de	à	±	
Ensemble						S. Ensemble	Dessiné	J.P	8.69
PULSED BEAM TRANSPORT						Echelle	Contrôlé		
CONNEXIONS						1/1	Vu		
ORGANISATION EUROPÉENNE POUR LA RECHERCHE NUCLÉAIRE						DIVISION			
CERN EUROPEAN ORGANIZATION FOR NUCLEAR RESEARCH						NPA		224.452.3	
1211 GENÈVE 23									

BIBLIOTHEQUE
28.10.69

CERN