

**THE PRODUCTION OF CHARMED PARTICLES IN  
HIGH-ENERGY  $^{16}\text{O}$ -EMULSION CENTRAL INTERACTIONS**

S. Aoki<sup>h)</sup>, A.C. Breslin<sup>e)</sup>, D.H. Davis<sup>g)</sup>, K. Hoshino<sup>h)</sup>, R. Ihara<sup>i)</sup>, M. Imada<sup>p)</sup>, T. Ishigami<sup>d)</sup>,  
M. Kazuno<sup>d)</sup>, H. Kitamura<sup>h)</sup>, M. Kobayashi<sup>d)</sup>, M. Kobayashi<sup>h)</sup>, K. Kodama<sup>h)</sup>, Y. Maeda<sup>p)</sup>,  
A. Marzari-Chiesa<sup>n)</sup>, M. Maserà<sup>n)</sup>, M.A. Mazzoni<sup>b)</sup>, F. Meddi<sup>l)</sup>, F. Minakawa<sup>d)</sup>, M. Miyanishi<sup>h)</sup>,  
M.T. Muciaccia<sup>a)</sup>, K. Nakamura<sup>h)</sup>, M. Nakamura<sup>h)</sup>, S. Nakanishi<sup>h)</sup>, K. Nakazawa<sup>e)</sup>, K. Niu<sup>h)</sup>,  
K. Niwa<sup>h)</sup>, M. Nomura<sup>h)</sup>, H. Okabe<sup>k)</sup>, G. Poulard<sup>b)</sup>, G. Romano<sup>m)</sup>, G. Rosa<sup>l)</sup>, Y. Sato<sup>o)</sup>,  
H. Shibuya<sup>d)</sup>, S. Simone<sup>a)</sup>, H. Tajima<sup>h)</sup>, S. Tasaka<sup>e)</sup>, M. Teranaka<sup>j)</sup>, I. Tezuka<sup>o)</sup>, D.N. Tovee<sup>g)</sup>,  
K. Tsukagoshi<sup>h)</sup>, N. Ushida<sup>f)</sup> and J. Yokota<sup>k)</sup>

**ABSTRACT**

The production of charmed particles has been detected in 200 GeV per nucleon  $^{16}\text{O}$ -emulsion central interactions. Their production cross-section in elementary nucleon-nucleon processes has been estimated to be

$$\sigma_{\text{charm}} = [14.1 \pm 9.3 \text{ (stat.)} \pm 8.4 \text{ (syst.)}] \mu\text{b}.$$

(Submitted to Physics Letters B)

- 
- a) Dipartimento di Fisica dell'Università and INFN, Bari, Italy.
  - b) CERN, Geneva, Switzerland.
  - c) Physics Department, University College Dublin, Eire.
  - d) Department of Physics, Toho University, Funabashi, Japan.
  - e) Faculty of Education, Gifu University, Gifu, Japan.
  - f) Aichi University of Education, Kariya, Japan.
  - g) Physics Department, University College London, UK.
  - h) Department of Physics, Nagoya University, Nagoya, Japan.
  - i) Department of Informatics, College of Sakuyo, Okayama, Japan.
  - j) Physics Department, Osaka City University, Osaka, Japan.
  - k) Science Education Institute of Osaka Prefecture, Osaka, Japan.
  - l) Dipartimento di Fisica, Università 'La Sapienza' and INFN, Rome, Italy.
  - m) Dipartimento di Fisica Teorica e SMSA dell'Università and INFN, Salerno, Italy.
  - n) Dipartimento di Fisica dell'Università and INFN, Turin, Italy.
  - o) Faculty of Education, Utsunomiya University, Utsunomiya, Japan.
  - p) Faculty of Education, Yokohama National University, Yokohama, Japan.

Heavy-flavour production in ultrarelativistic ion collisions may well impart information about the various stages of the collision process. In particular, the suppression of the production of  $J/\psi$  particles has been put forward as a possible signature of the formation of a quark-gluon plasma [1]. Such a suppression relative to the  $\mu\mu$  continuum was observed in central ion collisions [2]. Alternatively, mechanisms have recently been proposed [3], based on models of thermodynamic equilibrium, which would give rise to charmed-particle yields that are two orders of magnitude higher than the more conservative estimates based on the parton model. Such an enhanced charm-production rate would not only add to the overall  $\mu\mu$  continuum (through semileptonic decay), but would presumably also augment the  $J/\psi$  production rate through  $c\bar{c}$  recombination in the hadronization phase.

In these circumstances it was considered desirable to estimate the charmed-particle production rate directly in ultrarelativistic ion collisions, despite the great experimental difficulty of detecting decays of short-lived particles among events containing hundreds of secondary particles. This letter presents the results of such an analysis, performed on a sample of central  $^{16}\text{O}$ -emulsion (mainly Ag and Br) collisions obtained during the NA34/2 Emulsion-HELIOS programme with ion beams at CERN.

Stacks of Fuji ET-7B emulsion were exposed vertically to the 200 GeV/nucleon  $^{16}\text{O}$  beam at the CERN Super Proton Synchrotron (SPS). Each stack consisted of eight double-coated sheets, of area  $25 \times 15 \text{ cm}^2$  and 700  $\mu\text{m}$  thickness (a 70  $\mu\text{m}$  polystyrene base coated on both sides with a 315  $\mu\text{m}$  thick emulsion layer), and presented 4.2% of an  $^{16}\text{O}$ -emulsion interaction length to the beam.

Some  $5 \times 10^4$  interactions were collected in each stack, and central collisions were selected in which no projectile fragments with  $Z \geq 2$  remained and whose multiplicity exceeded 180 shower particles—about 5% of all observed inelastic interactions. The search was performed on a sample of 541 central interactions, the average shower multiplicity of which was 210.

Since very high multiplicities inhibit the tracing of individual tracks—which is generally the more reliable method of detecting decay vertices—the search for secondary interactions and decay vertices of both neutral and charged particles was performed by volume scan in the region defined in fig. 1. Whenever a decay-like topology was found, the search was repeated twice in order to detect a second one.

The scan found 347 charged secondary interactions and 68 neutral ones, all of them exhibiting evaporation tracks. A further 20 events occurred so close to the primary vertex that it was not possible to distinguish whether the parent was charged or neutral. More significantly, 40 ‘white’ stars with charged primaries and 15 with neutral ones were found, of which 28 and 13, respectively, showed decay-like topologies. Their details are summarized in table 1, where it can be seen that six pairs of decay-like events have been found.

In order to deduce the charm signal from the observed number of white stars, it is necessary to estimate both the contributions of background processes and the scanning efficiency. In some circumstances the background is dominant, and in these cases it is preferred to cut the sample and to estimate the corresponding loss of signal.

Five N2 topologies found within the scanned volume were coplanar with the primary interaction and are thus most likely to be interpreted as  $K_S^0$  decays. These have been rejected. If the  $K/\pi$  ratio in ion interactions is assumed [4] to be the same as in proton interactions at the same energy per nucleon, it is estimated that the efficiency of finding  $K_S^0$  decays is  $(57 \pm 25)\%$ . It is also calculated that the rejection of coplanar N2 events reduces the charm signal by 6%.

In order to reduce the background from electron pairs in the N2 topology to negligible proportions, only those events with an opening angle  $> 40$  mrad were accepted for inclusion in table 1. Furthermore, there had to be no detectable scattering on either track. It is estimated that also some 7% of charmed-particle decays with N2 topology were cut.

Events with C1 topology where the daughter was seen to scatter appreciably were rejected, such events being mainly due to low-momentum electrons. Similarly, C1 topologies exhibiting a small change in angle  $\Delta\theta$ , less than  $\theta$ , the angle made by the primary to the beam direction,  $\Delta\theta/\theta < 1$ , were also rejected. These are dominantly elastic scatterings, and it is estimated that some 16% of charmed-particle decays with C1 topology are lost by this cut.

The background from charged secondary nuclear interactions was estimated from the observed ratio of white stars to other stars in emulsion, 10% to 15%, and from the interaction mean free path of secondary charged particles (assumed to be pions) as a function of their momentum [5]. The momentum distribution was computed from the measured angular distribution in  $^{16}\text{O}$ -emulsion interactions, assuming that the  $p_T$  distribution is of the form

$$\frac{d\sigma}{dp_T^2} \propto \exp(-5p_T).$$

As expected, a large fraction of the background comes from interactions of low-momentum particles ( $< 10 \text{ GeV}/c$ ), and these contribute dominantly to C1 topologies (see table 1). The overall rate for both decay-like and non-decay-like white stars is estimated to be 0.1 per event.

The background due to nuclear interactions of neutral particles is estimated in a similar way, it being assumed that there are, on the average, eight neutrons, ten  $K^0$ , and three  $\Lambda$  ( $\bar{\Lambda}$ ) emitted per interaction. The interaction mean free path for kaons has been assumed to be the same as that for charged pions; for baryons, it is the same as for protons [6]. Since neutral particle interactions are much less numerous than charged ones, this source of background is expected to contribute correspondingly less than that due to charged particles (about 0.01 per event). Again, this fact is confirmed by the rates shown in table 1. An even lower contribution has been estimated for neutral particles produced in upstream interactions, which cannot be linked unambiguously to a given interaction. In this case, however,  $K_S^0$  decays cannot be rejected, as they generally do not fulfil the coplanarity condition. An overall rate of 0.003 per event is estimated.

Finally, because of their long lifetimes, the decays of  $K_L^0$  and of  $K^\pm$  mesons are not expected to contribute to the background to any noticeable extent.

From the above-mentioned sources it is estimated that there should be  $60^{+20}_{-13}$  singles and  $4^{+4}_{-2}$  pairs of white stars due to background. The probability of one of a charmed pair,  $p = 33.5\%$ , or both,  $q = 48.7\%$ , decaying within the scanned cylinder has been calculated assuming that the production characteristics are the same as those for 200 GeV proton interactions [7], and that the ratio of charged to neutral charm is 1:1. If  $D^*$  production is important, the ratio will become smaller, but this has very little effect on the values of  $p$  and  $q$ . Taking into account the above information and the experimental numbers presented in table 1, it is possible to determine the number of charm events  $N_{\text{charm}}$  in the sample, and also the efficiency  $\eta$  for finding a white star in one scan. The results are

$$N_{\text{charm}} = 14.0 \pm 9.3 \text{ (stat.)} \pm \frac{5}{8.3} \text{ (syst.)},$$

$$\eta = 0.547 \pm 0.083 \text{ (stat.)} \pm 0.160 \text{ (syst.)}.$$

Hence, one charmed pair is found in about forty central  $^{16}\text{O}$ -Ag(Br) collisions, and the ratio between charmed particles and charged mesons is  $R = 2.5 \times 10^{-4}$ .

These data lead to the following cross-section for charmed-particle production in elementary nucleon-nucleon collisions:

$$\sigma_{\text{charm}} = [14.1 \pm 9.3 \text{ (stat.)} \pm \frac{5}{8.4} \text{ (syst.)}] \mu\text{b},$$

assuming that the average number of participating projectile nucleons is 15, and that there is an  $A^1$  dependence of the cross-section. This dependence seems to be more appropriate in our conditions (strong selection on central events) than that found, for instance, in WA78 [8] ( $A^{0.8}$ ).

Two results [9, 10] indicate that with protons of the same energy interacting on different targets, the cross-section would be smaller, but still compatible within the errors. A compilation of data at different energies [11] and of results from QCD calculations, including next-to-leading corrections [12], are shown in fig. 2. It is seen that there is no huge increase in the charm production cross-section in central  $^{16}\text{O}$  interactions, over and above what might be expected from a superposition of N-N interactions.

Nevertheless, central interactions from higher-mass projectiles on larger target nuclei could well provide an unexpected result. In this case—as it is much more difficult to be free of background pairs of decay-like topologies in heavy-ion interactions than in interactions of protons or pions—any further experiment must be so designed that there is a low-density decay region beyond the target.

Support from the Mitsubishi Foundation, from the Japan Society for the Promotion of Science, and from the Monbusho International Scientific Research Program is greatly appreciated.

## REFERENCES

- [1] T. Matsui and H. Satz, *Phys. Lett.* **178B** (1986) 416.
- [2] A. Bussière et al., *Z. Phys.* **C38** (1988) 117.
- [3] T. Matsui, preprint MIT-CTP-1510 (1987).
- [4] K. Jaeger et al., *Phys. Rev.* **D11** (1975) 2405.
- [5] G. Baroni et al., CERN Em C63/16, 29.5.63 (unpublished).  
Z.V. Anzon et al., *Sov. J. Nucl. Phys.* **10** (1970) 570; *Nucl. Phys.* **B129** (1977) 205.  
S.C. Chakravartty et al., *Phys. Rev.* **C16** (1977) 1907.  
M. Juric et al., *Z. Phys.* **C22** (1984) 131.
- [6] H. Winzeler, *Nucl. Phys.* **69** (1965) 661.
- [7] M. Aguilar-Benitez et al., *Phys. Lett.* **189B** (1987) 476.
- [8] H. Cobbaert et al., *Phys. Lett.* **206B** (1988) 546.
- [9] O. Erriquez et al., *Phys. Scr.* **33** (1986) 202.
- [10] S. Barlag et al., *Z. Phys.* **C39** (1988) 451.
- [11] S.P.K. Tavernier, *Rep. Prog. Phys.* **50** (1987) 1439.
- [12] G. Altarelli et al., *Nucl. Phys.* **B308** (1988) 724.

**Table 1**

List of observed white stars.  $N_i$  and  $C_i$  stand for neutral and charged topologies, with  $i$  being the number of secondary charged prongs.  
 Note: C1 events with  $\Delta\theta/\theta < 1$  and N2 events with opening angle  $< 40$  mrad are not included.

	Decay-like		Not decay-like		Total
Pairs	N2 + C3	2	C3 + C2	1	7 + 1 *)
	C1 + C3	2	N2 + C4	1	
	C1 + N2	1 + 1 *)			
Singles	C1	14	C2	3	35 + 4 *)
	C3	5	C4	3	
	N2	3 + 4 *)	C6	3	
	N4	1	C8	1	
			N6	1	
			N8	1	

\*) N2 coplanar with primary vertex.

## Figure captions

- Fig. 1 Fiducial volume downstream from a primary interaction, for scanning secondary interactions and decay vertices.
- Fig. 2 Compilation of charmed-particle cross-section as a function of centre-of-mass energy [11]. Results from this experiment and from ref. [10] are included. Curves refer to QCD calculations with next-to-leading corrections [12].

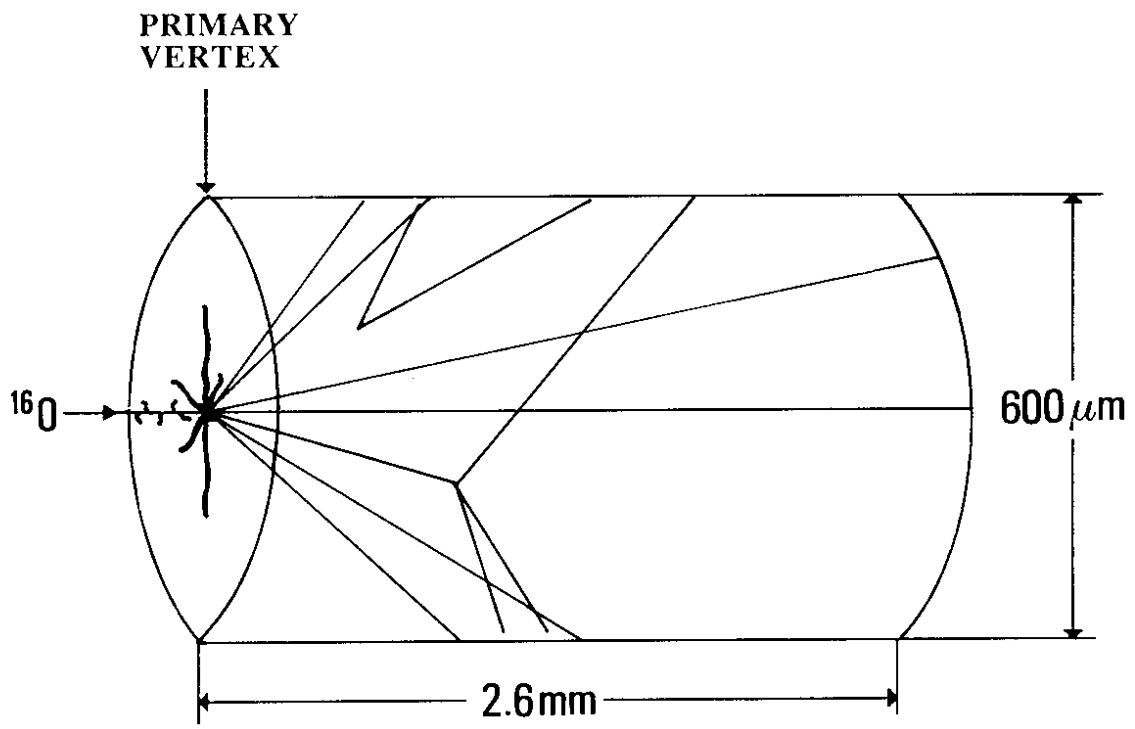

Fig. 1



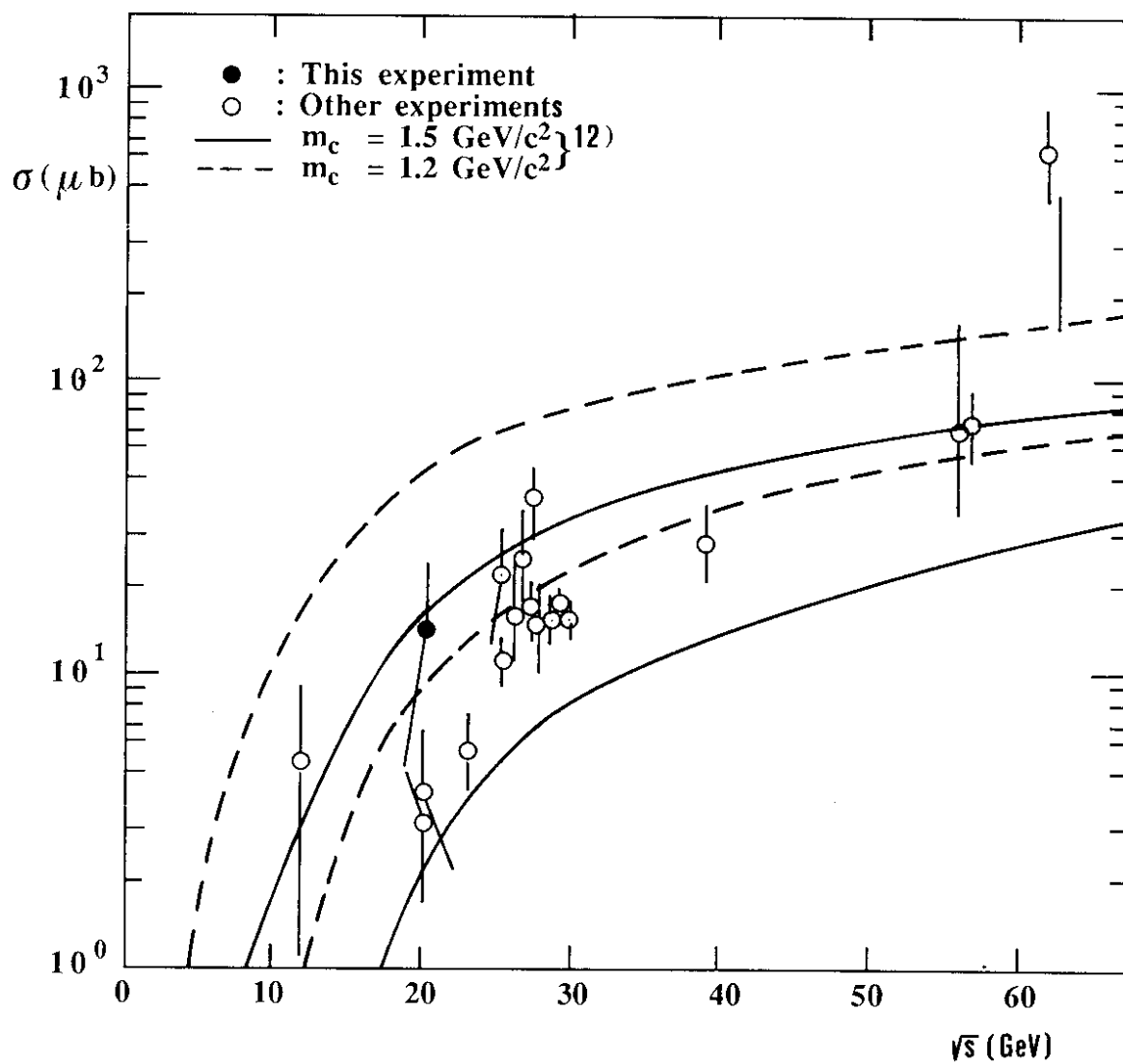

Fig. 2