



CERN-ACC-2014-0268

roberto.kersevan@cern.ch

Preliminary Design of the HiLumi-LHC Triplet Area Beam Screen

R. Kersevan, C. Garion, N. Kos
CERN, Geneva, Switzerland

Keywords: HL-LHC, HiLumi

Abstract

The so-called beam screen (BS) is a proven solution for intercepting the thermal loads caused by the circulating beams in the cryogenically-cooled sections of the LHC and minimizing dynamic vacuum effects [1]. The new triplet area foreseen for the HiLumi-LHC (HL-LHC) machine upgrade [2] has the additional feature of needing internal tungsten shields to reduce the amount of collision debris which is deflected by the high-gradient triplet magnets towards the superconducting magnets' cold masses and coils. The very aggressive optics design, based on large beam separations, calls for a maximum of physical space to remain available to the counter rotating beams in the common BS. This places severe constraints to the fabrication and installation tolerances of the BS itself, in addition to affecting the design and routing of the cryogenic lines in the area. The latest version of the BS design will be shown and discussed, together with future plans for testing materials, fabrication procedures, and installation.

Presented at: IPAC14, 15-20 June, Dresden, Germany

Geneva, Switzerland
October, 2014

CERN-ACC-2014-0268
11/11/2014



PRELIMINARY DESIGN OF THE HILUMI-LHC TRIPLET AREA BEAM SCREEN

R. Kersevan, C.Garion, N. Kos, CERN, Geneva, Switzerland

Abstract

The so-called beam screen (BS) is a proven solution for intercepting the thermal loads caused by the circulating beams in the cryogenically-cooled sections of the LHC and minimizing dynamic vacuum effects [1]. The new triplet area foreseen for the HiLumi-LHC (HL-LHC) machine upgrade [2] has the additional feature of needing internal tungsten shields to reduce the amount of collision debris which is deflected by the high-gradient triplet magnets towards the superconducting magnets' cold masses and coils. The very aggressive optics design, based on large beam separations, calls for a maximum of physical space to remain available to the counter rotating beams in the common BS. This places severe constraints to the fabrication and installation tolerances of the BS itself, in addition to affecting the design and routing of the cryogenic lines in the area. The latest version of the BS design will be shown and discussed, together with future plans for testing materials, fabrication procedures, and installation.

BACKGROUND

About 1.2 km of the present LHC ring will be modified during the LS3 shutdown, when the HL-LHC machine upgrade is scheduled to take place (see L. Rossi, "The HL-LHC Project", in [2]). Among the many new devices and components, and modifications to the existing hardware, a new shielded BS for the low- β triplets stands at the center of the project. Detailed calculations carried out by the FLUKA Team at CERN, and other members of the collaboration (see, for instance, N. Mokhov in [2]) indicate that without a properly designed BS shielded with a dense absorbing material, the energy deposition caused by the collision debris of the high-luminosity optics to the high-gradient Nb₃Sn triplet magnets would not make the latter survive for the planned 3000 fb⁻¹ integrated luminosity and would also exceed the cryogenic limit of their cold masses kept at 1.9 K, leading to a heavy burden on the cryogenic system of the machine, possibly leading to a magnet quench. It becomes therefore imperative to absorb and block as much as possible of this debris energy on the BS, and remove it at a higher temperature, to improve the Carnot efficiency of the process (see L. Taviani's presentation in [2]).

LATTICE AND MAGNET APERTURES

Without going into the details of the choice of the HL-LHC optics (see, for instance, R. De Maria's presentation in [2]) it can be said that the new optics need a 150 mm internal diameter (ID) for the new superconducting (SC)

Nb₃Sn triplet coils (see table on page 13 of E. Todesco's presentation in [2]). This choice, together with detailed analysis of the collision debris trajectories, has led to the proposal of a tungsten-shielded BS, where 4 inserts, placed on the vertical and horizontal planes of symmetry of the BS, absorb the vast majority of the debris and consequent nuclear showers (see L. Esposito, in [2]).

The material of choice is a tungsten-based industrial product already in use at CERN and elsewhere [3], which possesses the suitable mechanical, thermal and electric characteristics compatible with the vacuum environment of this particular application as well as the strength to sustain a magnet quench and related current discharge loads.

TRIPLET AREA CONFIGURATION

Fig.1 shows the arrangement of the different SC magnets along the triplet area, up to the beam recombination/separation D1 dipole.

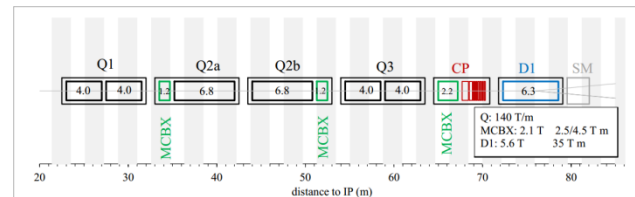

Fig.1 – Proposed HL-LHC triplet area magnet configuration

The shaded vertical areas are those forbidden for the installation of beam position monitors, placing an additional burden on the design and position of the cryostats' interconnects, and BS lengths. It can be seen that the Q1 quadrupole has a twin cold mass, with no sufficient longitudinal separation for two independent BS segments, and a total combined length of more than 8 meters. Likewise, the Q2 magnet is in reality made up of two independent cold masses, Q2a and Q2b, which will be separated by an interconnect section, allowing an independent BS inside each one of them. Note that Q2b and Q3 can be considered, in some ways, mirror-symmetric images of Q2a and Q1 respectively, taking the mentioned interconnect as the origin. For the two Q2s the length of the BS is also of the order of that of Q1 and Q3, i.e. 8 meters or so. The exact lengths of the BS segments will be fixed only after a detailed design of the quadrupoles' cold masses and cryostats will be available.

The tracking simulations of the collision debris and related nuclear showers have indicated that a thickness of 16 mm and 6 mm are, respectively, needed along the BS of the Q1 magnets and of the others, as indicated in Fig.2 (taken from L. Esposito, [2]).

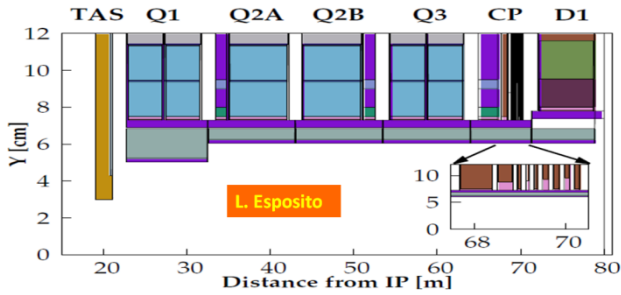

Fig.2 – Vertical cross section of the triplet area: Moving from the beam axis out radially, 2 mm-thick BS (magenta), Inermet 180 shielding (grey), 4 mm-thick cold-bore (magenta), 1.5 mm for the LHe ring (pink), cold masses (light blue).

BEAM SCREEN CROSS SECTION

The initial proposal for the BS cross section has been proposed by E. Todesco during a Work Package 3 meeting, and has quickly evolved into the concept shown in Fig.3, where the two versions are shown side by side.

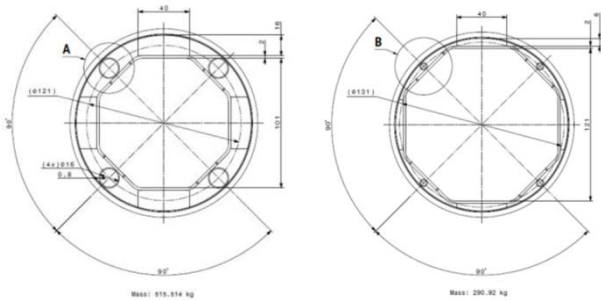

Fig.3 16mm (left) and 6mm (right) versions of the BS inside a 147 mm OD, 4 mm-thick cold bore. A radial gap of 0.2 mm is left between the BS Inermet inserts and cooling capillaries and the ID of the 1.9 K cold bore.

The very high density of the Inermet 180 (18.5 t/m^3) makes such that an 8 m-long BS with 16 mm-thick shielding weighs more than 500 kg, a feature which poses additional constraints on the procedure required to insert the BS inside the cold bore. Different options are being analysed at this time for this procedure, but are not reported here.

The cooling capillaries are now 4, instead of the usual 2 used in the arc regions of the LHC. It is evident from Fig.3 that the 16 mm version of the BS allows a large capillary diameter, while the 6 mm version does not, and therefore needs to be modified and improved, since a peak in the debris' energy deposition is expected in areas where the 6 mm BS version needs to be employed for beam stay clear and aperture reasons (see L. Esposito in [2]).

A worrying issue with any BS design and configuration is given by the requirement that the BS sustain without damage any magnet quench episode. The discharge curve of such a magnet quench has been calculated and the related electrodynamic and mechanical stresses have been

computed using the finite-element code CASTEM, see Fig.4 and 5.

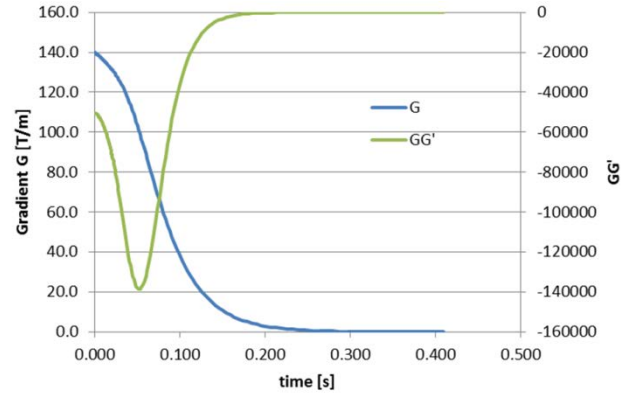

Fig.4 – Gradient $G(t)$ (left axis), and product of it with its gradient decay $G \cdot G'(t)$ (right axis) for an early version of the triplet magnets (140 T/m). It is $G \cdot G'$ which ultimately determines the mechanical forces. Realistic values for the resistivity of the Inermet 180 and the co-laminated Cu-stainless steel BS have been taken into account (see R. Kersevan, in [2]).

One representative snapshot of such a calculation is shown in Fig.5.

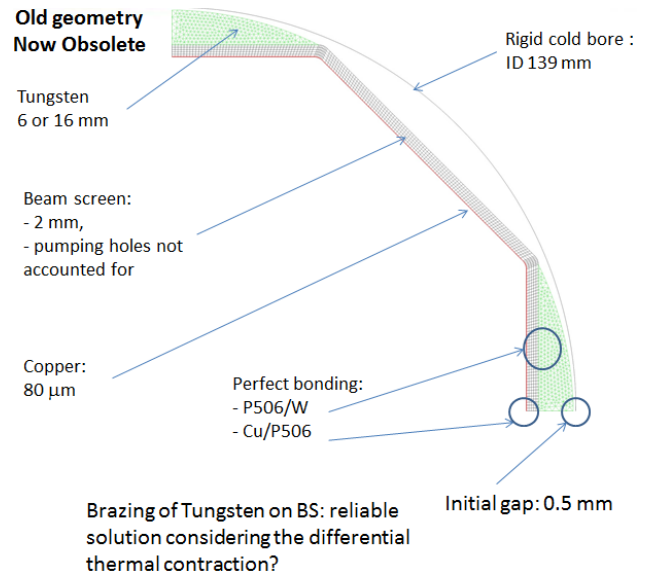

Fig.5 – Sample CASTEM calculation, showing the geometry and meshing implemented for the shielded BS.

The main results of the many calculations performed for different configurations of the BS thickness and shielding can be summarized as:

- A 2 mm-thick BS would undergo a plastic deformation during a quench, with maximum stress in the corners of the octagon-shaped BS, and possible detachment of the Inermet shielding from the external part of the BS co-laminated Cu-stainless steel sheet.

- A 1 mm-thick BS would, on the other hand, only undergo an elastic deformation during a quench, and is therefore preferred over the 2 mm one.
- The thickness of the co-laminated Cu layer inside the BS, assumed here to be 60 μm -thick as in the present LHC, is a major driver for the quench-induced currents and stresses, and needs therefore to be optimized, based also on transverse impedance considerations and requirements (see N. Mounet in [2]).
- The thermal exchange between the energy-absorbing Inermet shielding and the cooling capillaries must be optimized, in order to avoid that the shielding inserts take too high of a temperature, possibly leading to a thermal bridge with the 1.9 K cold bore, which would be really bad in terms of cryogenic load.

Some of these considerations have led to the recent modification of the cooling concept as the one schematized in Fig.6, where the Inermet inserts are blocked by many longitudinal centering pins, with oval openings in the inserts allowing for thermal contraction during cooldown, and rolling balls in place of the 0.2 mm-thick bronze sliding rings which were envisioned for the initial model, following the concept implemented in the present LHC arcs.

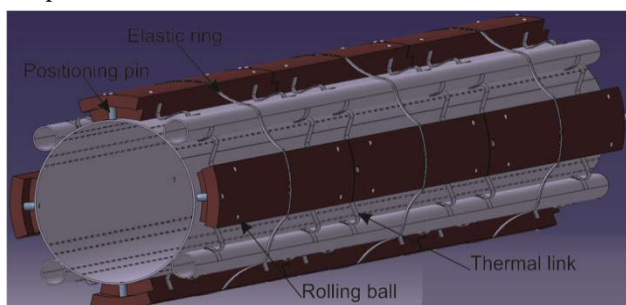

Fig.6 New concept for the BS. Cross-section to be optimized, the circular shape shown here is not representative of the final configuration.

The heat transfer between the Inermet inserts and the cooling capillaries is made via thin thermal links made up of copper. A careful analysis using finite-elements is underway in order to optimize this configuration.

FUTURE ACTIVITIES

- In the near future a short prototype made out of stainless steel is going to be fabricated in-house, in order to check the dimensional tolerances needed for the rolling balls, thermal links, positioning pins and elastic rings, together with the Inermet 180 inserts.
- Parts and materials have already been ordered, and will be assembled soon.
- Design of a $\sim 8\text{m}$ -long prototype of the 16 mm version is going to be started in parallel, aiming at having it ready for testing and dimensional checking within one year. In parallel, we are also exploring

ways to fabricate a high-tolerance cold bore pipe capable of minimizing any loss of radial space between the cold bore internal diameter and the external envelope circle of the shielded BS, thus maximizing the beam stay clear space.

- Within the Vacuum Surfaces and Coatings group we are also studying ways of depositing thin-film coatings aiming at reducing the secondary electron yield (SEY) and photon-induced desorption of the BS inner surface. In particular the SEY is deemed to be a key issue, as it could lead to a substantial increase of the heat load and beam losses due to electron cloud effects (see, for instance, G.Iadarola's and R. van Weelderens' presentations in [2]).
- A study program for characterizing the vacuum consequences and behaviour of a BS kept in the temperature range of 40~60 K [5] is also going to be started.

CONCLUSIONS

An analysis of the HL-LHC BS for the new triplet area has been carried out, taking into account all of the different issues related to beam optics (BS cross-section), energy deposition (BS shielding material), mechanical stability (co-laminated BS material, and bonding technologies to the other parts), beam stability (BS coatings to minimize/avoid impedance issues), etc..

We are confident that the concept and design of a reduced-scale prototype will confirm the theoretical results, and will lead us to a quick design of a full-scale prototype, and subsequent production of this key component of the HL-LHC project.

ACKNOWLEDGEMENTS

The HiLumi LHC Design Study is included in the High Luminosity LHC project and is partly funded by the European Commission within the Framework Programme 7 Capacities Specific Programme, Grant Agreement 284404.

The support of L. Dassa (CERN, EN-MME-ES) for the development of the early BS drawings is acknowledged.

REFERENCES

- [1] "LHC Machine", LHC design report, abridged version, IOP and SISSA, 2008, L. Evans, P Briant Editors, http://iopscience.iop.org/1748-0221/3/08/S08001/pdf/1748-0221_3_08_S08001.pdf
- [2] 3rd Joint HiLumi LHC-LARP Annual Meeting, Daresbury, 11-15 Nov 2013: <https://indico.cern.ch/event/257368/contributions>
- [3] Inermet 180 TM, PLANSEE Tungsten Alloys, CIME BOCUZE, St Pierre en Faucigny, France.
- [4] E. Todesco, private communication.
- [5] V. Baglin et al., CERN-ATS-2013-00, and 24th International Cryogenic Engineering Conf., Fukuoka, May 2012