

INTERNATIONAL JOURNAL OF HIGH-ENERGY PHYSICS

CERN COURIER

VOLUME 52 NUMBER 5 JUNE 2012



The DarkSide of Gran Sasso



SCIENCE

Images reveal the brain's grid-like connections

p11

SPACE

Edoardo Amaldi and the first steps towards ESA

p25



SILICON IN 3D

Detectors take on a new dimension **p19**



Technology Leadership. Agilent's New 4UHV Ion Pump Controller

The first true 4 channel ion pump controller for Ultra High Vacuum

Agilent Technologies, as Varian Vacuum Products, invented the ion pump in 1957 and lead the UHV market in ion pump technology ever since.

Now there's more... the new Agilent 4UHV gives you the ability to operate 4 ion pumps all at once or just one at a time. This means ion pumps of any type in sizes from 20 to 500 I/s.

www.agilent.com/chem/vacuum

Toll Free: Canada/US 800.882.7428 Europe 00.800.234.234.00



© Agilent Technologies, Inc. 2012

The Measure of Confidence



Agilent Technologies

Covering current developments in high-energy physics and related fields worldwide

CERN Courier is distributed to member-state governments, institutes and laboratories affiliated with CERN, and to their personnel. It is published monthly, except for January and August. The views expressed are not necessarily those of the CERN management.

Editor Christine Sutton
News editor Kate Kahle
Editorial assistant Carolyn Lee
 CERN, 1211 Geneva 23, Switzerland
E-mail cern.courier@cern.ch
Fax +41 (0) 22 785 0247
Web cerncourier.com

Advisory board Luis Álvarez-Gaumé, James Gillies, Horst Wenninger

Laboratory correspondents:
Argonne National Laboratory (US) Cosmas Zachos
Brookhaven National Laboratory (US) P Yamin
Cornell University (US) D G Cassel
DESY Laboratory (Germany) Till Mundt
EMFCSC (Italy) Anna Cavallini
Enrico Fermi Centre (Italy) Guido Piragino
Fermi National Accelerator Laboratory (US) Katie Yurkewicz
Forschungszentrum Jülich (Germany) Markus Buescher
GSI Darmstadt (Germany) I Peter
IHEP, Beijing (China) Tongzhou Xu
IHEP, Serpukhov (Russia) Yu Ryabov
INFN (Italy) Romeo Bassoli
Jefferson Laboratory (US) Steven Corneliussen
JINR Dubna (Russia) B Starchenko
KEK National Laboratory (Japan) Youhei Morita
Lawrence Berkeley Laboratory (US) Spencer Klein
Los Alamos National Laboratory (US) Rajan Gupta
NGSL (US) Ken Kingery
Nikhef (Netherlands) Paul de Jong
Novosibirsk Institute (Russia) S Eidelman
Orsay Laboratory (France) Anne-Marie Lutz
PSI Laboratory (Switzerland) P-R Kettle
Saclay Laboratory (France) Elisabeth Locci
Science and Technology Facilities Council (UK) Julia Maddock
SLAC National Accelerator Laboratory (US) Farnaz Khadem
TRIUMF Laboratory (Canada) Marcello Pavan

Produced for CERN by IOP Publishing Ltd
 IOP Publishing Ltd, Temple Circus, Temple Way,
 Bristol BS1 6BE, UK
 Tel +44 (0)117 929 7481

Publisher Susan Curtis
Production editor Jesse Karjalainen
Technical illustrator Alison Tovey
Group advertising manager Ed Jost
Recruitment advertisement manager Chris Thomas
Advertisement production Katie Graham
Marketing & Circulation Angela Gage

Head of B2B & Marketing Jo Allen
Art director Andrew Giaquinto

Advertising
 Tel +44 (0)117 930 1026 (for UK/Europe display advertising)
 or +44 (0)117 930 1164 (for recruitment advertising);
 E-mail: sales@cerncourier.com; fax +44 (0)117 930 1178

General distribution Courier Adressage, CERN, 1211 Geneva 23, Switzerland
 E-mail: courier-adressage@cern.ch
 In certain countries, to request copies or to make address changes, contact:
China Keqing Ma, Library, Institute of High Energy Physics,
 PO Box 918, Beijing 100049, People's Republic of China
 E-mail: keqingma@mail.ihep.ac.cn
Germany Veronika Werschner, DESY, Notkestr. 85, 22607 Hamburg, Germany
 E-mail: desypr@desy.de
Italy Loredana Rum or Anna Pennacchietti, INFN, Casella Postale 56, 00044 Frascati,
 Rome, Italy
 E-mail: loredana.rum@inf.infn.it
UK Mark Wells, Science and Technology Facilities Council, Polaris House, North Star
 Avenue, Swindon, Wiltshire SN2 1SZ
 E-mail: mark.wells@stfc.ac.uk
US/Canada Published by Cern Courier, 6N246 Willow Drive,
 St Charles, IL 60175, US. Periodical postage paid in St Charles, IL, US
 Fax 630 377 1569. E-mail: creative_mailing@att.net
 POSTMASTER: send address changes to: Creative Mailing Services, PO Box 1147,
 St Charles, IL 60174, US

Published by European Organization for Nuclear Research, CERN,
 1211 Geneva 23, Switzerland
 Tel +41 (0) 22 767 61 11. Telefax +41 (0) 22 767 65 55

Printed by Warners (Midlands) plc, Bourne, Lincolnshire, UK

© 2012 CERN ISSN 0304-288X

IOP Publishing



CERN COURIER

VOLUME 52 NUMBER 5 JUNE 2012

5 NEWS

- IceCube observations challenge ideas on cosmic-ray origins
- CMS discovers the Ξ_b^{*0} • Dijets confirm the Standard Model
- Ramping up to higher luminosity • Deferred triggering optimizes CPU use • RENO observes disappearance of electron-antineutrinos • Hungary to host extension to CERN data centre

11 SCIENCEWATCH

12 ASTROWATCH

13 ARCHIVE

FEATURES

- 14 **ALICE tracks charm energy loss in the QGP**
Results on the energy loss of charm quarks in lead collisions at the LHC.
- 19 **Silicon sensors go 3D**
Producing radiation-hard tracking detectors for the ATLAS upgrade.
- 22 **The DarkSide of Gran Sasso**
Towards new levels of sensitivity in detecting dark-matter particles.

25 Edoardo Amaldi and the origins of ESA

In 1958, Edoardo Amaldi set out his vision for a European organization for research in space in a letter that has now itself gone into space.



- 29 **CO₂ cooling is getting hot in high-energy physics**
The benefits of carbon-dioxide cooling for silicon detectors.

32 FACES & PLACES

39 RECRUITMENT

42 BOOKSHELF



On the cover: Installation of the 4-m diameter vessel for the neutron veto in the DarkSide experiment at the Gran Sasso National Laboratory (p22). (Image credit: Yury Suvorov for the DarkSide collaboration.)

Celebrate up to 5 maintenance-free years



Service intervals others
can't hold a candle to



nXDS

Discover more at
www.edwardsvacuum.com/nXDS

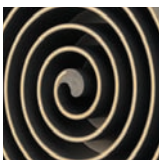

nXDS - the great new shape of
high performance dry vacuum pumping

 **EDWARDS**

Vacuum science... product solution.



News

COSMIC RAYS

IceCube observations challenge ideas on cosmic-ray origins

The IceCube collaboration, with a detector that looks at a cubic kilometre of ice at the South Pole, has searched for evidence of neutrinos associated with gamma-ray bursts (GRBs). They find none at a level 3.7 times lower than models predict, indicating that cosmic rays with energies above 10^8 TeV originate from some other source.

Where nature accelerates particles to 10^8 TeV has been one of the long-standing questions of extreme astrophysics. Although the flux of the highest-energy cosmic rays arriving at Earth is small, it pervades the universe and corresponds to a large amount of energy. Equally mysterious in origin, gamma-ray bursts (GRBs), some associated with the collapse of massive stars to black holes, have released a small fraction of a solar mass of radiation more than once a day since the Big Bang. The assumption is that they invest a similar amount of energy in the

acceleration of protons, which explains the observed cosmic-ray flux. This leads to the 15-year-old prediction that when protons and gamma rays co-exist in the GRB fireball they photoproduce pions that decay into neutrinos. The prediction is quantitative (albeit with astrophysical ambiguities) because astronomers can calculate the number of photons in the fireball, and the observed cosmic-ray flux dictates the number of protons. Textbook particle physics then predicts the number of neutrinos.

With 5160 photomultiplier tubes, the IceCube experiment has transformed a cubic kilometre of Antarctic ice into a Cherenkov detector (*CERN Courier* March 2011 p28). Even while still incomplete, the instrument reached the sensitivity to observe GRBs, taking data with 40 and 59 of the final number of 86 photomultiplier strings. The measurement is relatively easy

because it exploits alerts from the NASA's Swift satellite and Fermi Gamma-Ray Space Telescope to look for neutrinos arriving from the right direction at the right time. The window is small enough to do a background-free measurement because accidental coincidence with a high-energy atmospheric neutrino is negligible.

During the periods of data-taking, some 307 GRBs had the potential to result in neutrinos that IceCube could detect. However, the experiment found no evidence for any neutrinos that could be associated with the GRBs. This implies either that GRBs are not the only sources of cosmic rays with energies exceeding 10^8 TeV or that the efficiency of neutrino production is much lower than has been predicted.

With GRBs on probation, the stock rises for the alternative speculation that associates supermassive black holes at the centres of galaxies with the enigmatic cosmic accelerators.

Further reading

IceCube collaboration 2012 *Nature* **484** 351.

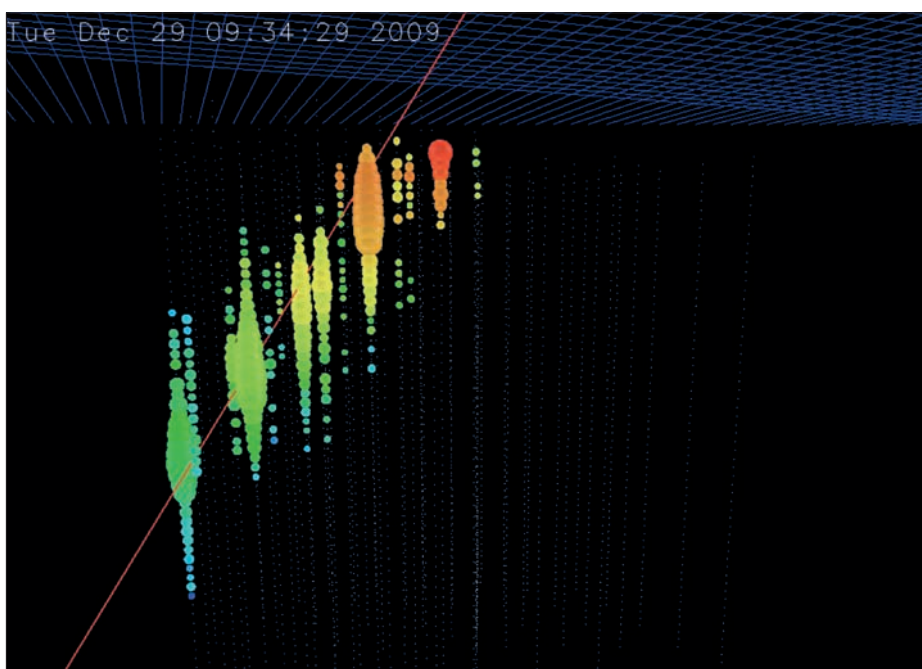

An IceCube event within 0.2° of the direction of a gamma-ray burst (GRB) observed by the Swift satellite. The reconstruction yields an energy of 109 TeV and an angular error of 0.2° . Although it misses the time of the GRB by 14 hours, the background is so low that this was the most significant candidate.

Sommaire en français

Les observations d'IceCube remettent en question l'origine des rayons cosmiques	5
CMS découvre le Ξ_b^0	6
Les dijets confirment le Modèle standard	6
Un déclenchement retardé pour optimiser le temps CPU	7
Montée en luminosité	7
RENO observe la disparition d'antineutrinos électroniques	8
La Hongrie va héberger une extension du centre de données du CERN	9
Les connexions du cerveau auraient une structure de grille	11
Un trou noir pris la main dans le sac après un meurtre stellaire	12

News

LHC PHYSICS

CMS discovers the Ξ_b^{*0} 

The CMS experiment has discovered its first new particle. The new state is observed with a significance exceeding 5σ and a mass of 5945.0 ± 2.8 MeV. This mass and the observed decay mode are consistent with its being the beauty-strange baryon known as Ξ_b^{*0} .

Understanding the detailed spectroscopy of the various families of hadrons has been a quest of scientists ever since quarks were recognized as being the building blocks of protons, neutrons and other hadrons. Baryons are composed of three quarks and if they contain a beauty (b) quark and a strange (s) quark then they are members of the Ξ_b family. Depending on whether the third valence quark is a u or a d, the resulting baryon is either the neutral Ξ_b^0 or the charged Ξ_b^\pm . While the charged and neutral lowest-mass states were already known, none of the heavier states had so far been seen. The newly discovered particle is probably the Ξ_b^{*0} , with a total angular momentum and parity, $J^P = 3/2^+$. Its observation helps in understanding how quarks bind and in further validating the theory of strong interactions.

The observation was made in a data sample of 5.3 fb^{-1} proton–proton collisions at a centre-of-mass energy of 7 TeV, delivered by the LHC in 2011. Figure 1 shows a typical event, where a candidate Ξ_b^{*0} (also appropriately called the “cascade b baryon”) leads to a cascade of decays, $\Xi_b^{*0} \rightarrow \Xi_b^0 \pi^+$, $\Xi_b^0 \rightarrow J/\Psi \Xi^-$, $J/\Psi \rightarrow \mu^+ \mu^-$, $\Xi^- \rightarrow \Lambda^0 \pi^-$ and $\Lambda^0 \rightarrow p \pi^-$, ending in one proton, two muons, and three pions. The existence of the Ξ_b^{*0} is established by detecting all of these particles and measuring the charge, momentum

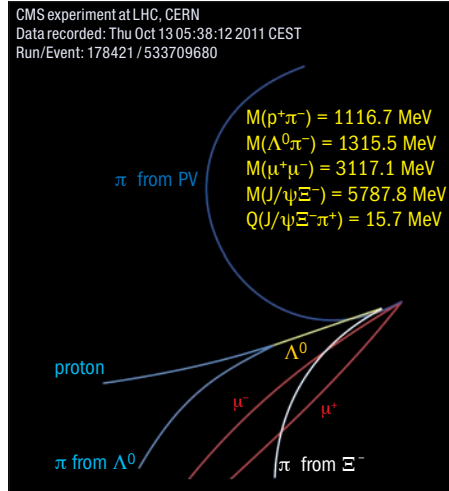

Fig. 1. Display of a typical event, showing the reconstructed decay products of the newly discovered particle.

and point of origin (the vertex) for each one. Requiring that the secondary decay vertices be displaced from the primary vertex reduces the background caused by random combinations of uncorrelated particles, which are copiously produced in high-energy proton–proton collisions.

The invariant-mass distribution of the $J/\Psi \Xi^-$ pairs shows a clear peak corresponding to the Ξ_b^0 signal, with a mass in good agreement with the world average. The Ξ_b^{*0} is expected to decay promptly to $\Xi_b^0 \pi^+$ pairs, so candidates were sought by combining the reconstructed Ξ_b^0 with a track (assumed to be a pion) coming from the primary vertex. To cancel measurement errors partially and so increase the sensitivity,

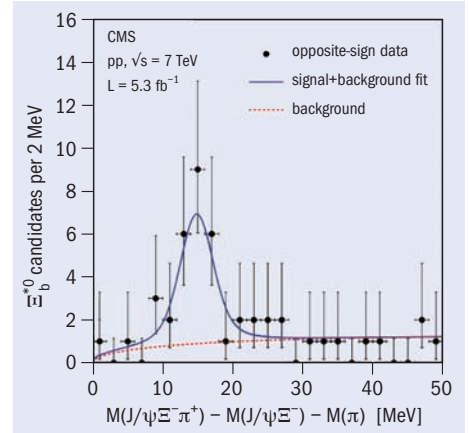

Fig. 2. Mass-difference distribution, revealing the new beauty (b) baryon.

the analysis looked at the mass difference $Q = M(J/\Psi \Xi^- \pi^+) - M(J/\Psi \Xi^-) - M(\pi)$. Figure 2 shows the mass difference for 21 events in the range $12 < Q < 18$ MeV, which clearly exceed the 3.0 ± 1.4 events expected in the absence of a new particle.

The detection of this new particle was possible thanks only to the excellent tracking and vertexing capabilities of the CMS experiment, combined with high-purity dimuon triggers that identify decays of the J/Ψ meson “on the fly”, before storing the events. This measurement shows that CMS can unravel complicated chains of particle decays and bodes well for future discoveries of rare particles.

• Further reading

CMS collaboration 2012 arXiv:1204.5955v1 [hep-ex].

Dijets confirm the Standard Model



Dijet measurements provide an excellent tool not only to probe high transverse-momentum parton interactions to study QCD but also to look for signs of new phenomena beyond the Standard Model. Thanks to the outstanding performance of the LHC in 2011, the ATLAS experiment recorded nearly 30,000 events with dijet masses above 2 TeV and even observed dijet masses up to 4.6 TeV.

The collaboration has used the full 2011 data sample – corresponding to nearly

5 fb^{-1} of integrated luminosity – for a measurement of the dijet cross-section as a function of mass and rapidity difference. The data were first corrected for detector effects – paying particular care to the effect of possible multiple interactions per beam crossing – and the measured cross-sections were then compared with various predictions of QCD. While there are small deviations in some models at the higher end of the spectrum, overall the agreement with QCD is reasonably good.

QCD predicts that the cross-section falls steeply with dijet mass. New, as yet

unobserved, particles would typically give rise to resonances or bumps on top of this smoothly falling spectrum. ATLAS observes no bumps, allowing limits to be set on a number of theories that predict such particles.

Angular distributions can also be used to search for deviations from the Standard Model. They are typically measured in bins of dijet mass, where the scattering angle is transformed into a variable known as χ (see figure). The Standard Model predicts that these distributions should be relatively flat, while many theories beyond the Standard Model predict a rise at low values of χ .

The measured distributions are found to be in agreement with QCD predictions, allowing limits to be set on various models for new physics. For one of these models, where quarks are no longer fundamental particles but are instead composite objects, this analysis sets a limit on the compositeness scale – the scale of the constituent binding energies – at 7.8 TeV.

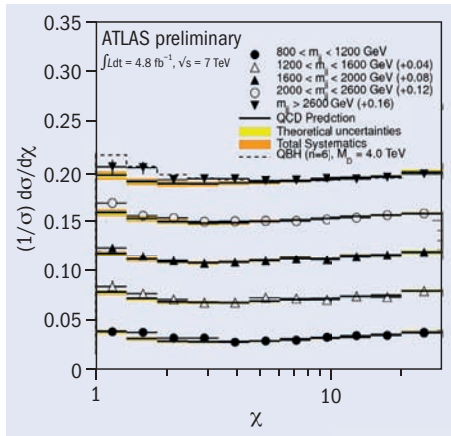

Dijet angular distributions as a function of $\chi = \exp(|y_1 - y_2|)$ in five bins of dijet mass show no sign of new physics.

LHC NEWS

Ramping up to higher luminosity

After a flying start, with the first stable beams at the new energy of 4 TeV on 5 April, the LHC successfully operated with 1380 bunches per beam – the maximum planned for 2012 – on 18 April. In the days that followed, the machine reached a record peak luminosity of about $5.6 \times 10^{33} \text{ cm}^{-2} \text{ s}^{-1}$, with a bunch intensity of 1.4×10^{11} protons per bunch and a new highest stored energy of 120 MJ per beam.

As it entered a two-day machine-development period on 21–22 April, almost 1 fb^{-1} of data had been delivered to the experiments, a feat that took until June in 2011. The machine development focused on topics relevant for the 2012 physics-beam operation and was followed by a five-day technical stop, the first of the year.

The restart from 27 April onwards was slowed down by several technical faults that led to low machine availability and the ramp back up in intensity took longer than initially planned. LHC operation was further hampered by higher than usual beam losses in the ramp and squeeze. These required time to investigate the causes and to implement mitigation measures.

Deferred triggering optimizes CPU use



Like all of the LHC experiments, LHCb relies on a tremendous amount of CPU power to select interesting events out of the many millions that the LHC produces every second. Indeed, a large part of the ingenuity of the LHCb collaboration goes into developing trigger algorithms that can sift out the interesting physics from a sea of background. The cleverer the algorithms, the better the physics, but often the computational cost is also higher. About 1500 powerful computing servers in an event filter farm are kept 100% busy when LHCb is taking data and still more could be used.

However, this enormous computing power is used less than 20% of the time when averaged over the entire year. This is partly because of the annual shutdown, so preparations are under way to use the power of the filter farm during that period for offline processing of data – the issues to be addressed include feeding the farm with events from external storage. The rest of the idle time is a result of the gaps between the periods when there are protons colliding in the LHC (the “fills”), which typically last between two and three hours, where no collisions take place and therefore no computing power is required.

This raises the question about whether it is

somehow possible to borrow the CPU power of the idle servers and use it during physics runs for an extra boost. Such thoughts led to the idea of “deferred triggering”: storing events that cannot be processed online on the local disks of the servers, and later, when the fill is over, processing them on the now idle servers.

The LHCb Online and Trigger teams quickly worked out the technical details and started the implementation of a deferred trigger early this year. As often happens in online computing, the storing and moving of the data is the easy part, while the true challenge lies in the monitoring and control of the processing, robust error-recovery and careful bookkeeping. After a few weeks, all of the essential pieces were ready for the first successful tests using real data.

Depending on the ratio of the fill length to inter-fill time, up to 20% of CPU time can be deferred – limited only by the available disk space (currently around 200 TB) and the time between fills in the LHC. Buying that amount of CPU power would correspond to an investment of hundreds of thousands of Swiss francs. Instead, this enterprising idea has allowed an increase in the performance of its trigger, allowing time for more complex algorithms (such as the online reconstruction of K_s decays) to extend the physics reach of the experiment.

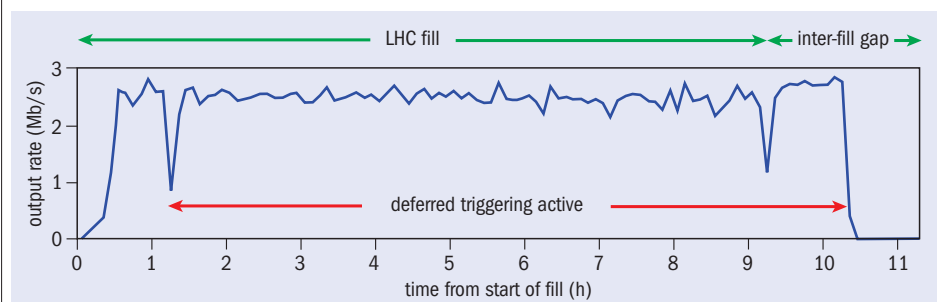

Measured output rate to permanent storage of one of the LHCb servers during and after an LHC fill. The output rate increases by a few per cent after the end of a fill – because of the reduced network traffic – while the remaining, locally stored events are processed.

On 10 May the machine began running again with 1380 bunches and a couple of days later saw one of the year’s best fills, lasting for 13 hours and delivering an integrated luminosity of 120 pb^{-1} to ATLAS and CMS. By 15 May, after careful optimization of the

beams in the injectors, the luminosity was back up to pre-technical-stop levels. The aim now is for steady running accompanied by a gentle increase in bunch intensity in order to deliver a sizeable amount of data in time for the summer conferences.

Raise your profile,
showcase your
achievements.



The IOP Innovation Awards
celebrate excellence in
physics-based innovation.

From aerospace to oil extraction
and computer games to medical
technologies, the innovative use
of physics is at the core of
successful businesses across
the UK and Ireland.

To enter, and for more information
and full terms and conditions, visit
www.iop.org/innovation or e-mail
innovation.awards@iop.org.

Image: Polystyrene insulating material, SEM Eye Of
Science/Science Photo Library

IOP Institute of Physics

News

NEUTRINOS

RENO observes disappearance of electron-antineutrinos

The Reactor Experiment for Neutrino Oscillations (RENO) has performed a definitive measurement of the neutrino-oscillation mixing angle, θ_{13} , by observing the disappearance of electron-antineutrinos emitted from a nuclear reactor, with a significance of 4.9σ

RENO detects antineutrinos from six reactors, each with a thermal power output of $2.8 \text{ GW}_{\text{th}}$, at Yonggwang Nuclear Power Plant in Korea. The reactors are almost equally spaced in a line about 1.3 km long and the experiment uses two identical detectors located at 294 m and 1383 m on either side of the centre of this line, beneath hills that provide, respectively, 120 and 450 m of water-equivalent of rock overburden to reduce the cosmic backgrounds. This symmetric arrangement of reactors and detectors is useful for minimizing the complexity of the measurement. RENO is the first experiment to measure θ_{13} , the smallest neutrino-mixing angle and the last to be known, with two identical detectors.

In the 229-day data-taking period from 11 August 2011 to 26 March 2012, the far (near) detector observed 17,102 (154,088) electron-antineutrino candidate events with a background fraction of 5.5% (2.7%). During this period, all six reactors were operating mainly at full power, with two reactors being off for a month each for fuel replacement.

The two identical antineutrino detectors allow a relative measurement through a comparison of the observed neutrino rates. Measuring the far-to-near ratio of the reactor neutrinos in this way can considerably reduce several systematic errors. The relative measurement is independent of correlated uncertainties and helps in minimizing uncorrelated reactor uncertainties.

Each detector comprises four layers. At the core lies the target volume of 16.5 tonnes of liquid scintillator that is doped with gadolinium. An electron-antineutrino can interact with a free proton in the scintillator, $\bar{\nu} + p \rightarrow e^+ + n$. The positron from this inverse β -decay annihilates immediately giving a prompt signal. The neutron wanders into the target volume, eventually being captured by the gadolinium – giving a delayed signal. The delayed coincidence

between the positron and neutron signals provides the distinctive signature of inverse β -decay.

The central target volume is surrounded by a 60 cm layer of liquid scintillator without gadolinium, which serves to catch γ -rays escaping from the target volume, thus increasing the detection efficiency. Outside this γ -catcher, a 70 cm buffer-layer of mineral oil shields the inner detectors from radioactivity in the surrounding rocks and in the 354 photomultiplier tubes (10-inch) that are installed on the inner wall of the buffer container. The outermost veto layer consists of 1.5 m of pure water, which serves to identify events coming from the outside through their Cherenkov radiation and to shield against ambient γ -rays and neutrons from the surrounding rocks. Both detectors are calibrated using radioactive sources and cosmic-ray induced background samples.

Based on the number of events at the near detector and assuming no oscillation, RENO finds a clear deficit, with a far-to-near ratio $R = 0.920 \pm 0.009$ (stat.) ± 0.014 (syst.). The value of $\sin^2 2\theta_{13}$ is determined from a χ^2 fit with pull terms on the uncorrelated systematic uncertainties. The number of events in each detector after the background subtraction has been compared with the expected number of events, based on the neutrino flux, detection efficiency, neutrino oscillations and contribution from the reactors to each detector determined by the baselines and reactor fluxes. The best-fit value obtained is $\sin^2 2\theta_{13} = 0.113 \pm 0.013$ (stat.) ± 0.019 (syst.), which excludes the no-oscillation hypothesis at 4.9σ .

The RENO collaboration consists of about 35 researchers from Seoul National University, Chonbuk National University, Chonnam National University, Chung Ang University, Dongshin University, Gyeongsang National University, Kyungpook National University, Pusan National University, Sejong University, Seokyeong University, Seoyeong University and Sungkyunkwan University.

● Further reading

JK Ahn *et al.* RENO collaboration 2012 *Phys. Rev. Lett.* **108** 191802.

CERN

Hungary to host extension to CERN data centre

Following a competitive call for tender, CERN has signed a contract with the Wigner Research Centre for Physics in Budapest for an extension to CERN's data centre. Under the new agreement, the Wigner Centre will host CERN equipment that will substantially extend the capabilities of Tier-0 of the Worldwide LHC Computing Grid (WLCG) and provide the opportunity to implement solutions for business continuity. The contract is initially until 31 December 2015, with the possibility of up to four one-year extensions thereafter.

The WLCG is a global system organized in tiers, with the central hub being Tier-0 at CERN. Eleven major Tier-1 centres around the world are linked to CERN via dedicated



Artist's impression of the new data centre. (Image credit: Wigner Research Centre.)

high-bandwidth links. Smaller Tier-2 and Tier-3 centres linked via the internet bring the total number of computer centres involved to more than 140 in 35 countries. The WLCG serves a community of some 8000 scientists working on LHC experiments, allowing seamless access, distributed computing and data-storage facilities.

The Tier-0 at CERN currently provides some 30 PB of data storage on disk and includes the majority of the 65,000 processing cores in the CERN Computer Centre. Under the new agreement, the Wigner Research Centre will extend this capacity with 20,000 cores and 5.5 PB of disk storage, and will see this doubling after three years.

Les physiciens des particules du monde entier sont invités à apporter leurs contributions aux CERN Courier, en français ou en anglais. Les articles retenus seront publiés dans la langue d'origine. Si vous souhaitez proposer un article, faites part de vos suggestions à la rédaction à l'adresse cern.courier@cern.ch.

CERN Courier welcomes contributions from the international particle-physics community. These can be written in English or French, and will be published in the same language. If you have a suggestion for an article, please send proposals to the editor at cern.courier@cern.ch.



Neutron detection with scintillators: an alternative to He-3

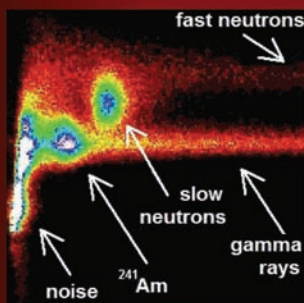

Lil(Eu), liquid cells

¹⁰B, Gd loading

SCIONIX Holland B.V.

Tel. +31 30 6570312

Fax. +31 30 6567563

Email. sales@scionix.nl

www.scionix.nl

**Contact us for
more information**

ET Enterprises
electron tubes

New Photomultiplier HV Base

Using photomultipliers is now even easier with a new range of compact, low noise, HV Bases from ET Enterprises.

Incorporating socket, voltage divider and HV supply, they are suitable for use with a wide range of photomultipliers operating in analogue, pulse counting or photon counting modes.

- range of input voltage (5V to 15V)
- output voltage adjustable from 100V to 2000V
- very low power
- high stability

Visit our new website for further information.

ET Enterprises is now your single source for 'Electron Tubes' and ADIT photomultipliers, including many Photonis replacements.

Use our new interactive website to search our complete range of products or follow the contact links to discuss your application.



ET Enterprises Limited, Riverside Way,
Uxbridge, UB8 2YF, UK
Phone: +44 (0)1895 200880
Fax: +44 (0)1895 270873
sales@et-enterprises.com
www.et-enterprises.com

ADIT Electron Tubes, 300 Crane Street,
Sweetwater, Texas 79556, USA
Phone: (325) 235 1418
Fax: (325) 235 2872
sales@electron tubes.com
www.electrontubes.com



Verify and optimize your designs with COMSOL Multiphysics®

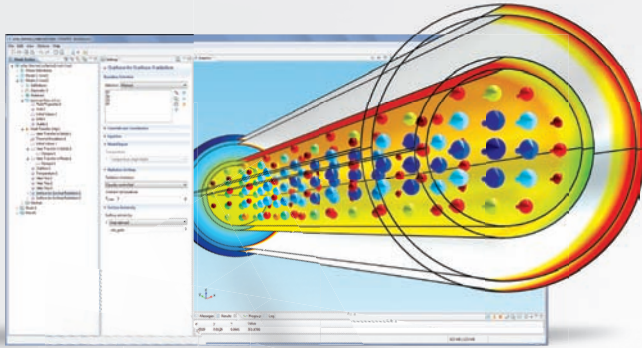

SOLAR ENERGY: Heat is transferred by surface-to-surface radiation from the outside shell to the pipe walls.

Multiphysics tools let you build simulations that accurately replicate the important characteristics of your designs. The key is the ability to include all physical effects that exist in the real world. Order a free CD containing 700 multiphysics presentations at www.comsol.com/confcd



©2012 COMSOL



+49.351.26996-0
www.iseq-hv.com



HPS
SERIES NEW GENERATION!

**HIGH VOLTAGE
HIGH POWER
HIGH PRECISION**

- Up to 80 kV / up to 10 kW
- Very high efficiency (up to 93%)
- Filament supply available
- ARC management adjustable
- Extended operation range (power regulation)
- C-charger models available

NOW UP TO 80 KV / UP TO 10 KW | VARIOUS APPLICATIONS

Sciencewatch

COMPILED BY JOHN SWAIN, NORTHEASTERN UNIVERSITY

Brain fibres reveal a grid-like structure

Many people visualize the connections between neurons in the brain as being extremely complex and close to random-looking in their distribution. However, it turns out that they are laid out much like a grid. Using diffusion magnetic-resonance (MR) imaging on brains of humans and other primates, Van Wedeen of Massachusetts General Hospital in Boston and colleagues found sheets of nerve fibres that run at right angles to each other and to other sheets, making the brain's wiring look like a 3D grid and remarkably free of "spaghetti" wiring.

Higher primates had more curvature to the lines but the sheet structure remained.

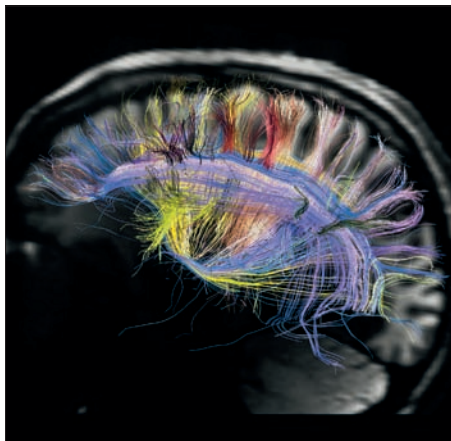

The work has important implications for understanding the human brain and could help elucidate how evolution could make small incremental changes in brain wiring without radically altering overall function.

● Further reading

VJ Wedeen *et al.* 2012 *Science* **335** 1628.

Diffusion spectrum MR image of human brain showing the curvature of two-dimensional sheets of parallel neuronal fibres that cross at right angles. (Image credit: Martinos Center for Biomedical Imaging, Massachusetts General Hospital, MGH-UCLA Human Connectome Project.)

Synthetic DNA

Life on Earth uses "backbones" of DNA or RNA to store and carry genetic information represented by bases. Now, the same functionality has been achieved with different "backbones". Philipp Holliger of the MRC Laboratory of Molecular Biology in Cambridge and colleagues have made six different xenonucleic acids (XNAs) in which they replaced the sugars in DNA and RNA with other molecules.

The standard enzymes that copy information would not work for these XNAs, so the researchers modified them until they did the job. Now the team can copy information from an XNA to DNA and back to another XNA – somewhat like a retrovirus, with XNA playing the role of RNA. The work opens up the possibility that life on other worlds could well have developed using a biochemistry similar to that on Earth – but with XNAs in place of the DNA and RNA. This would truly be life, but not at all as we know it.

● Further reading

VB Pinheiro 2012 *Science* **336** 341.

Lasing without light

Atomic clocks using optical transitions provide the most accurate measurements of time but require reference resonators that bounce laser light back and forth between two mirrors. However, tiny changes in the length of the resonator always occur as a result of thermal fluctuations

Graphene's silicon sister

Given the similarity between carbon and silicon, is there a silicon analogue of graphene – "silicene"? Patrick Vogt of Aix-Marseille University and the Technical University of Berlin and colleagues have found that the answer is, "yes". They deposited layers of silicon onto silver by evaporation from a heated silicon wafer. Because there is no silicon analogue of graphite from which to peel off layers of silicene, the fabrication is a little more complex. Both the structural and the electronic properties support the formation of silicene. (Previous attempts used only observations by scanning-transmission microscope.)

The road may now be open to silicene electronics. The material may be much easier to integrate with current silicon technology than graphene, opening up a range of new devices.

● Further reading

P Vogt *et al.* 2012 *Phys. Rev. Lett.* **108** 155501.

and they shift the resonant frequency.

Justin Bohnet at the University of Boulder in Colorado and colleagues have found a clever way round the problem. Rather than storing coherence in the electromagnetic field between the mirrors, they store it in the coherent excitations of more than a million rubidium-87 atomic dipoles placed between them. This makes a "laser" with an average of less than 0.2 of a photon inside the cavity, which is 10,000 times less sensitive to

displacements of the mirrors.

Achieving the "superradiant" mode requires using an external laser to drive the rubidium atoms between two long-lived states to mimic a narrow atomic transition. Nevertheless, it seems to work and coherence can be preserved in the atoms for milliseconds. Apart from its great novelty, the technique could dramatically increase the precision in measuring that most elusive of quantities – time.

● Further reading

JG Bohnet *et al.* 2012 *Nature* **484** 78.

Disappearing dark matter

Christian Moni Bidin of the University of Concepción in Chile and colleagues used historical survey data, as well as newer data from the La Silla and Las Campanas Observatories in Chile, to track more than 400 stars within 13,000 light-years of Earth. The result is surprising. They can account for all of the stars' motions using just the visible mass present and no dark matter – a far cry from the 83% or so of the total matter in the universe that is usually attributed to dark matter. What this will turn out to mean is still not clear but it could explain why terrestrial dark-matter detectors have not yet found any. It could be that there is not much of it, at least around the vicinity of Earth.

● Further reading

C Moni Bidin *et al.* 2012, arXiv:1204.3924v1 [astro-ph.GA], accepted by *Ap. J.*

Astrowatch

COMPILED BY MARC TÜRLER, ISDC AND OBSERVATORY OF THE UNIVERSITY OF GENEVA

Black hole is seen feasting on a stellar core

Astronomers have gathered the most direct evidence yet of a supermassive black hole shredding a star that wandered too close to it. By following the event over hundreds of days they could identify for the first time the nature of the victim, a helium-rich stellar core.

Supermassive black holes – weighing a few to a thousand million times more than the Sun – are known to exist in the centre of most galaxies and, like volcanoes, they can be active or dormant. In active galactic nuclei (AGN) they receive a continuous supply of gas sustaining their activity, whereas in quiet galaxies – such as the Milky Way – they remain dormant because of the lack of matter to accrete. However, as soon as a star ventures too close to a resting black hole it can suddenly awake in a flare of radiation. Because this happens on average only about once every 10,000 years per galaxy, astronomers have so far detected only a few such events.

Numerical simulations of this kind of event show how the star gets stretched and eventually disrupted in the vicinity of the black hole by the strong gradient of the gravitational field, which exerts more attraction on the near side of the star than on its far side. The observed emission comes from heated gas that is on the verge of falling into the black hole, while the remaining part of the stellar material forms a long tail of gas that is ejected at high speeds.

The new tidal disruption event, published in *Nature* by Suvi Gezari of the Johns Hopkins University in Baltimore and collaborators, is the first to be discovered in the visible range: all previous ones were detected in X-rays

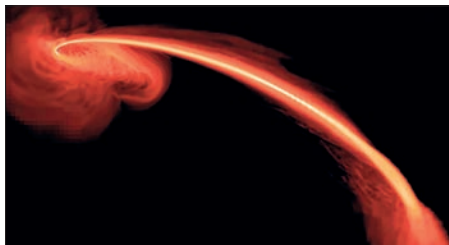

This computer-simulated image shows gas from a tidally disrupted star that passed too close to a supermassive black hole (in the upper-left corner). While some of the gas is falling into the black hole, some is ejected into space at high speed. (Image credit: NASA, S Gezari/Johns Hopkins University and J Guillochon/Univ. of California Santa Cruz.)

(*CERN Courier* April 2004 p12, July/August 2011 p14). The Pan-STARRS1 telescope on the summit of Haleakala in Hawaii first detected the optical transient PS1-10jh on 31 May 2010. The Panoramic Survey Telescope and Rapid Response System (Pan-STARRS) scans the entire night sky for all kinds of transient phenomena, including supernovae. The event was discovered independently as a near-ultraviolet transient by NASA's Galaxy Evolution Explorer (GALEX) satellite on 17 June 2010. Subsequent observations by both instruments traced its rise in intensity until 12 July 2010 and its slow decay until September 2011. The flare amplitude in the ultraviolet was found to be much too high for an AGN outburst and its brightness rise too slow to be consistent with a supernova explosion.

By comparing the observed evolution

of the brightness with results of numerical simulations of tidal-disruption events, Gezari and colleagues not only confirmed this scenario but could even constrain the internal structure of the incoming star. They find that the star cannot be too centrally concentrated and hence suggest that the doomed star was not a solar-type star but rather a fully convective star or a degenerate stellar core. The latter interpretation is corroborated by a spectral study of the source that shows broad helium-emission lines, but no Balmer lines from hydrogen. This suggests that the outer hydrogen layer of the star was already lost prior to the encounter with the black hole.

A likely scenario is that the star was once a red giant that has lost its hydrogen envelope in one or several previous, less dramatic, fly-bys of the black hole, preserving just a helium-rich stellar core for the final encounter. This stellar core could be only about a quarter of the mass of the Sun and imply a black hole of about 3 million solar masses, which is similar to the one at the centre of the Milky Way. This dramatic event was witnessed by watching a galaxy 2.7 thousand million light-years away. Pan-STARRS is looking at thousands of galaxies for such events and is expected to detect one every two years or so. This will offer new opportunities to probe the effects of general relativity and may even determine whether the supermassive black hole is spinning or not.

● Further reading

S Gezari *et al.* 2012 *Nature* 485 217.

Picture of the month

To celebrate its 22nd anniversary, the Hubble Space Telescope offers a new view of the Tarantula Nebula. This turbulent, star-forming region in the Large Magellanic Cloud – a small, nearby galaxy – can be compared with previous views by ESO's Very Large Telescope (*CERN Courier* June 2006 p14, January/February 2007 p11). Also known as 30 Doradus – a name referring to a single star, which is as it appears to the unaided eye – the nebula is the biggest and most active star-forming region in our Local Group of galaxies, including the Milky Way and the Andromeda Galaxy. The star cluster at its heart is so massive and dense that it could in the future become a globular cluster (*CERN Courier* May 2012 p14). (Image credit: NASA, ESA and ESO; D Lennon and E Sabbi/ESA/STScI; J Anderson, S E de Mink, R van der Marel, T Sohn, and N Walborn/STScI; N Bastian/Excellence Cluster Munich; L Bedin/INAF Padua; E Bressert/ESO; P Crowther/Sheffield; A de Koter/Amsterdam; C Evans/UKATC/STFC Edinburgh; A Herrero/IAC Tenerife; N Langer/AiFA Bonn; I Platais/JHU; and H Sana/Amsterdam.)



CERN Courier Archive: 1969

A LOOK BACK TO CERN COURIER VOL. 8, JUNE 1969, COMPILED BY PEGGIE RIMMER

RUTHERFORD

Concrete magnets

Wrapping up synchrotron magnet coils poses no small problem. They have to be electrically insulated, both from the magnet yoke and one turn of the coil from another, and the insulation usually has to mechanically hold the coil together. The electrical insulation is straightforward but the mechanical stresses are considerable, as is the risk of destruction by radiation.

In thinking about this problem, R Sheldon and G B Stapleton of the Rutherford Laboratory have proposed a novel method of magnet construction. It involves using concrete – more precisely castable ceramics which are highly resistant to irradiation – to “pot” the whole magnet as an “integral structure”. The coil is wound without any insulation and assembled onto the magnet yoke, using spacers to avoid electrical contact. Assembly is done inside a steel pipe and concrete is pumped in under pressure.

Small magnets (up to 50 cm long) have been built and tested, and have indicated that the method gives the required insulation and retains the necessary tolerances following thermal cycling and pulsing. This new concept holds out the prospect of magnets which could be cheaper and free from the problems of radiation damage.

● Compiled from texts on pp172–173.

CERN

Development of multiwire proportional chambers

Quite often, theoreticians, confronted with some major difficulty, have successfully gone back 30 years to look at ideas that had been thrown overboard. But it is rare that experimentalists go back 30 years to look again at equipment which had become out-dated. This is what Charpak and his colleagues did.

In the 1930s, ion-chambers, Geiger-Muller counters and proportional counters were vital pieces of equipment in nuclear-physics research; other types of detectors have since largely replaced them. Now the introduction of micro-electronics makes it possible to purchase miniature components for amplification of the signal on a wire for a thousandth of the cost only 10 years ago, and the proportional counter is making a

comeback in a new array – the “multiwire proportional chamber” – which has several features, making it a very useful addition to the armoury of particle detectors.

[There followed a masterly account, by Georges Charpak, of the meticulous manner in which the best of detector R&D is done, finishing with the following remarks.]

At present, we lack sufficient experience to know what their [multiwire chambers] limitations are. Several groups are investigating various aspects of the mechanism of amplification so it may therefore be expected that information will very soon be available for work on large units. Already, certain applications are being actively studied where proportional chambers can probably play a very useful part: in low-energy nuclear physics in the focal planes of spectrometers and, maybe, in medical physics for constructing large surface detectors which measure the spatial distribution of X-rays emitted by radioactive elements in human organs.

● Compiled from texts on pp174–176.

SPACEFLIGHT

Watch this space

On 4 June, Russell L Schweickart came to CERN to talk on “The Flight of Apollo 9 and the Future of Space Exploration”. It is estimated that about 1250 people came to CERN that night to hear the astronaut (in the Main Auditorium, and elsewhere via closed-circuit TV) and a further 1250 saw projections of the film, *Apollo 9*, on the following two days.

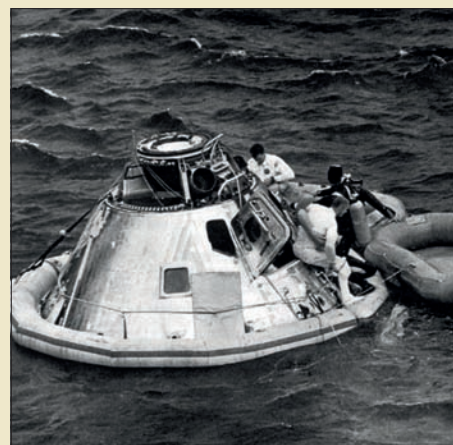

Russell Schweickart climbs out of the Apollo 9 capsule at the end of the mission. (Image credit: NASA.)

Schweickart was Lunar Module pilot of the Apollo 9 mission. He was launched into space on 3 March to carry out, in Earth orbit, a series of tests on the Lunar Excursion Module, the small spacecraft which has to separate from the parent capsule when in lunar orbit to carry two astronauts down to the surface of the moon and back. During the flight, the techniques of transferring men from the command module to the lunar module, the separation of the two craft and their “docking” were successfully tested. These tests were repeated in lunar orbit during the Apollo 10 flight and all is now ready for the historic Apollo 11 mission due to be launched on 16 July for the first landing of man on the moon on 20 July.

● Compiled from texts on p177.

Compiler's Note

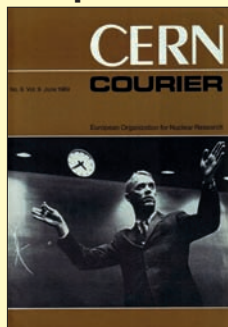

These three stories heralded three breakthroughs.

The Large Electron-Positron collider was the first accelerator to use concrete magnets. With conventional magnets unaffordable, 3392 concrete dipoles were installed for half of the cost.

The first moonwalk was on 23 July 1969. Now the Moon is a potential training ground for astronauts preparing for Mars landings.

The Charpak genie was out of the bottle when his multiwire proportional chamber and subsequent developments launched the era of fully electronic particle detection. In an early example of knowledge transfer, the increased recording speeds allowed faster scanning and lower body doses in diagnostic tools for nuclear medicine.

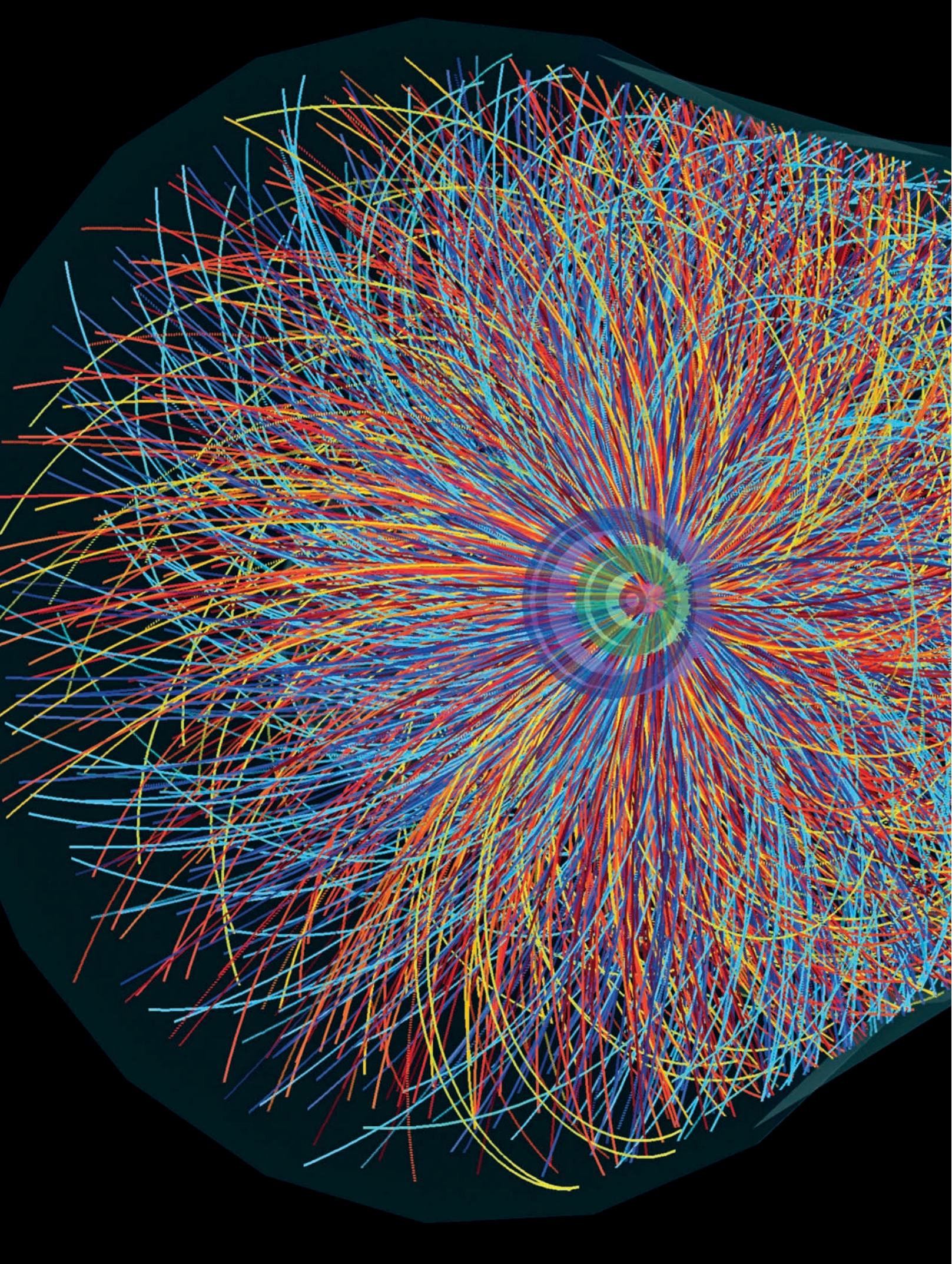

ALICE tracks charm energy loss in the QGP

The first direct observation of the suppression of charmed mesons at high transverse-momentum in head-on nucleus–nucleus collisions indicates that charm quarks suffer a strong loss of energy in hot quark–gluon plasma.

When heavy nuclei collide at high energies, a high-density colour-deconfined state of strongly interacting matter is expected to form. According to lattice QCD calculations, the confinement of coloured quarks and gluons into colourless hadrons vanishes under the conditions of high energy-density and temperature that are reached in these collisions and a phase transition to a quark–gluon plasma (QGP) occurs.

The LHC, operating with heavy ions, is nowadays the frontier machine for exploring the QGP experimentally, but such studies began 25 years ago with fixed-target experiments at the Alternating Gradient Synchrotron at Brookhaven and the Super Proton Synchrotron at CERN. The field entered the collider era in 2000 with Brookhaven’s Relativistic Heavy-Ion Collider (RHIC). Experiments there showed that initial hard partonic collisions produce energetic quarks and gluons that interact with the hot and dense QGP, probing its properties and, more generally, those of the strong interaction in an extended many-body system. The abundant production of these “hard probes” constitutes one of the leading opportunities that have opened up at the LHC – where collisions of heavy ions have nearly a 14-fold increase in centre-of-mass energy with respect to RHIC – and their extensive study is a leading feature of the heavy-ion programmes of the ALICE, ATLAS and CMS experiments.

Heavy quark probes

High-momentum partons are created in hard-scattering processes that occur in the early stage of the nuclear collision. They subsequently traverse the hot QGP, losing energy as they interact with its constituents. This energy loss is expected to occur via inelastic

processes (gluon radiation induced in the medium, or radiative energy loss, analogous to bremsstrahlung in QED) and via elastic processes (collisional energy loss).

The massive c and b quarks ($m_c \sim 1.5 \text{ GeV}/c^2$, $m_b \sim 5 \text{ GeV}/c^2$) are useful probes of these energy-loss mechanisms. In QCD, quarks have a lower colour coupling-strength than gluons, thus the energy loss should be smaller for quarks than for gluons. At LHC energies, hadrons containing light flavours originate mainly from gluons. Therefore, charmed mesons provide an experimental tag for a low colour-charge, quark parent. In addition, the “dead-cone effect” should reduce small-angle gluon radiation for heavy quarks that have moderate energy-over-mass values, i.e. for c and b quarks with momenta up to about $10 \text{ GeV}/c$.

The nuclear modification factor, R_{AA} , is one of the observables that are sensitive to the interaction of hard partons with the medium. This quantity is defined as the ratio of particle production measured in nucleus–nucleus (AA) interactions to that expected on the basis of the proton–proton (pp) spectrum, scaled by the average number of binary nucleon–nucleon collisions occurring in the collisions of the nuclei. Loss of energy in the medium leads to a suppression of hadrons at moderate-to-high transverse momentum ($p_t > 2 \text{ GeV}/c$), so $R_{AA} < 1$. In the range $p_t < 10 \text{ GeV}/c$, where the masses of the heavy c and b quarks are not negligible with respect to their momenta, the properties of parton energy-loss described above mean that an increase in R_{AA} (i.e. a smaller suppression) is expected when going from the mostly gluon-originated light-flavour hadrons (such as pions) to D and B mesons with c quarks and b quarks, respectively: $R_{AA}(\pi) < R_{AA}(D) < R_{AA}(B)$.

The measurement and comparison of these different probes provides a unique test of how the energy loss of the partons depends on their colour charge and mass. Because these dependences are predicted by QCD, their experimental verification is a crucial step for the understanding of the properties of the strongly interacting medium.

Experiments at RHIC reported a strong suppression, by a factor of 4–5 at $p_t > 5 \text{ GeV}/c$, for light-flavour hadrons in central collisions of gold nuclei at a centre-of-mass energy $\sqrt{s_{NN}} = 200 \text{ GeV}$. The suppression of heavy-flavour hadrons, measured inclusively from their decay electrons by the PHENIX and STAR experiments, turned out to be similar to that of pions and generally stronger than most expectations based on radiative energy loss. This striking \triangleright

Left: An event display of a lead–lead collision in ALICE, with the layers of the inner tracking system highlighted. These play an important role in identifying charmed mesons among the thousands of particles that are produced.

LHC physics

observation raised high expectations for the separate measurements of charm and beauty hadrons in the collisions of lead ions at $\sqrt{s_{NN}} = 2.76$ TeV at the LHC. Such a study is favoured by the abundant production yields (e.g. about 50 $c\bar{c}$ pairs per central collision, according to perturbative QCD calculations) and by the design of the LHC experiments, all of which have excellent capabilities for the detection of heavy flavour.

Charmed meson suppression

In the ALICE experiment, the charmed mesons D^0 , D^+ and D^{*+} are reconstructed in the central barrel through their decays to charged hadrons, namely $D^0 \rightarrow K^- \pi^+$, $D^+ \rightarrow K^- \pi^+ \pi^+$ and $D^{*+} \rightarrow D^0 \pi^+$, followed by $D^0 \rightarrow K^- \pi^+$. The signal is extracted from the invariant-mass distributions of the combinations of charged tracks reconstructed in the inner tracking system (ITS) and the time-projection chamber (TPC). The high-multiplicity environment of lead–lead (PbPb) interactions, where about 1600 primary charged particles per unit of rapidity are produced for head-on collisions, is particularly challenging for the exclusive reconstruction of D-meson decays because of the large combinatorial background. However, the signal-to-background ratio can be enhanced by requiring the separation of the D^0 and D^+ decay vertices from the interaction vertex. This separation, typically of a few hundred microns, is resolved thanks to the high-spatial-precision hits measured by the six-layer silicon ITS. Background is reduced further using the excellent particle-identification capabilities provided by the measurement of the specific energy deposit in the TPC and of the particle time-of-flight (TOF) from the interaction vertex to the TOF detector. The D-meson yields are corrected for detector effects and for the contribution from B-meson decays. The nuclear modification factor R_{AA} is then computed using as the pp reference the cross-section measured at 7 TeV centre-of-mass energy and scaled – via perturbative QCD calculations – to the PbPb energy of 2.76 TeV (ALICE collaboration 2012a).

Figure 1 shows the nuclear modification factor measured by ALICE in the transverse momentum interval $6 < p_t < 12$ GeV/c, as a function of the collision centrality for the three species of D meson (ALICE collaboration 2012b). The centrality of the collision is determined from the measured particle multiplicity and it is quantified by the average number of participant nucleons, $\langle N_{part} \rangle$, i.e. nucleons that suffered at least one inelastic scattering with a nucleon of the other nucleus. The more central the collision, the larger the number of participant nucleons. The observed suppression increases (R_{AA} decreases) with increasing centrality – as expected because of the larger, hotter and denser medium created in more central collisions – reaching a factor of about four for head-on collisions.

Figure 2 shows the average R_{AA} of the three D-meson species as a function of the transverse momentum for the most central collisions (ALICE collaboration 2012b). To study the expected dependences of the energy loss on colour charge and parton mass, the nuclear modification factor is compared with those of charged hadrons measured by ALICE and those of non-prompt J/ψ mesons (from B decays) measured by the CMS experiment for $p_t > 6.5$ GeV/c (CMS collaboration 2012). The charged-hadron nuclear modification factor is dominated by light flavours and coincides with that of charged pions above $p_t \approx 5$ GeV/c. This comparison between the

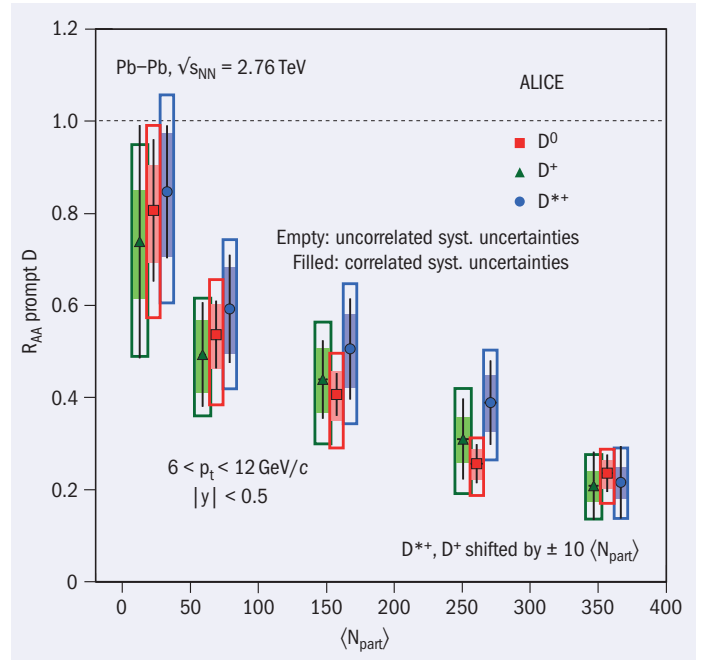

Fig. 1. Centrality dependence of R_{AA} for prompt D mesons with $6 < p_t < 12$ GeV/c.

values of R_{AA} for D mesons and charged hadrons shows that the average nuclear modification factor for the D mesons is close to that of charged hadrons. However, considering that the systematic uncertainties of D mesons are not fully correlated with p_t , there is an indication for $R_{AA}(D) > R_{AA}(\text{charged})$. The suppression of J/ψ from B decays is clearly weaker than that of charged hadrons, while the comparison with D mesons is not conclusive and requires more differential and precise measurements of the transverse momentum dependence.

Apart from final-state effects, which are related to the formation of a hot and deconfined medium, initial-state effects are also expected to influence the nuclear modification factor, because it is nuclei rather than nucleons that collide. In particular, the modification of the parton distribution functions (PDFs) of the nucleons in the nuclei affects the initial hard-scattering probability and, thus, the yields of energetic partons, including heavy quarks. In the kinematic range relevant for charm production at LHC energies, the main effect is nuclear shadowing, which induces a reduction in the yields of D mesons at low momentum. As shown in

Models based on parton energy loss describe well the measured suppression of high-momentum charmed mesons.

figure 3, a perturbative QCD calculation supplemented with a phenomenological parameterization of the nuclear modification of the PDFs indicates that the shadowing-induced effect on R_{AA} is limited to $\pm 15\%$ for $p_t > 6$ GeV/c. This suggests that the strong suppression observed in the high- p_t data is a final-state effect, arising predominantly from energy loss of c quarks in the medium.

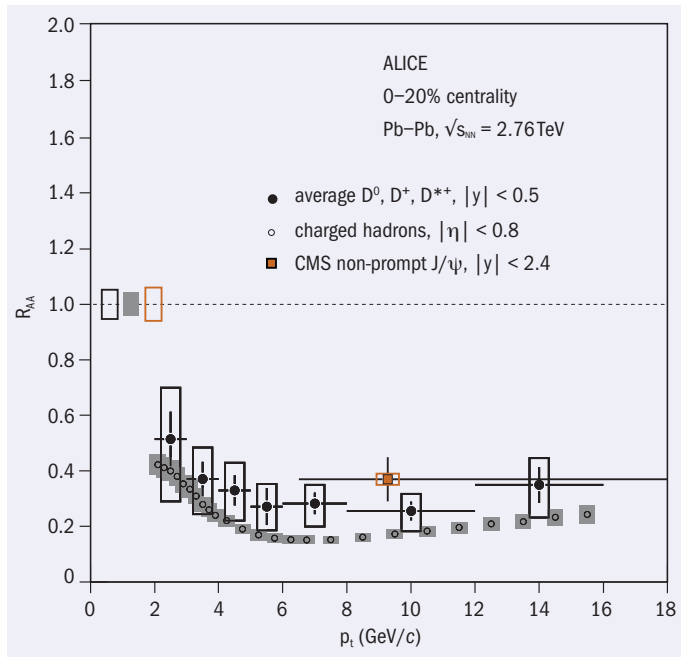

Fig. 2. Average R_{AA} of D mesons in the 0–20% centrality class compared with the nuclear modification factors of charged hadrons and non-prompt J/ψ from B decays in the same centrality class. The boxes at $R_{AA}=1$ represent the relative normalization uncertainties.

Theoretical models based on parton energy loss describe well the measured suppression of high-momentum charmed mesons. Figure 3 displays the comparison with the data of some selected models that within the same framework compute the suppression of particles with heavy and light flavour. A thorough validation of the ingredients of the models, which differ from one another, requires a systematic comparison, extended to higher momentum, over a range in collision centrality for a variety particle species, in particular beauty hadrons. This will eventually provide important constraints on the energy density of the hot QGP formed at the LHC.

In conclusion, the first ALICE results on the nuclear modification factor R_{AA} for charm hadrons in PbPb collisions at a centre-of-mass energy $\sqrt{s_{NN}}=2.76$ TeV indicate strong in-medium energy loss for charm quarks. There is a possible indication, which is not fully significant with the current level of experimental uncertainties, that $R_{AA}(D) > R_{AA}(\text{charged})$. The precision of the measurements will be improved in the future, using the large sample of PbPb collisions recorded in 2011. In addition, proton–lead collisions will provide insight into possible initial-state effects, which may play an important role, mainly in the low-momentum region.

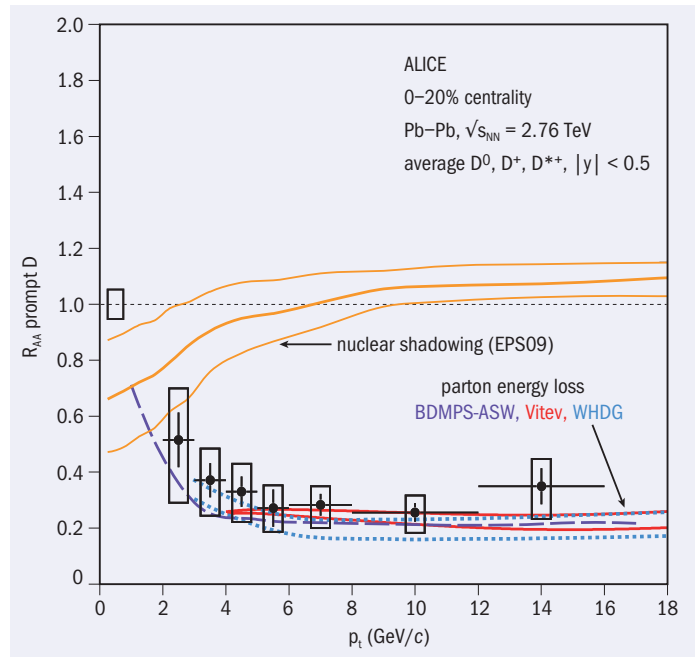

Fig. 3. Average R_{AA} of D mesons in the 0–20% centrality class compared with a perturbative QCD calculation that is supplemented with nuclear shadowing and to models that implement parton energy loss.

• Further reading

ALICE collaboration 2012a *JHEP* **1201** 128, arXiv:1111.1553.

ALICE collaboration 2012b arXiv:1203.2160.

CMS collaboration 2012 arXiv:1201.5069.

Résumé

ALICE cherche la perte d'énergie du charme dans le plasma

La collaboration ALICE a publié de premiers résultats concernant la production de mésons charmés (D^0 , D^+ et D^{+}) dans les collisions plomb–plomb au LHC. Dans les collisions centrales, où l'on s'attend à voir se former un plasma quarks–gluons chaud et dense, la production à une impulsion transversale élevée est largement réduite par rapport aux attentes fondées sur les mesures relatives aux collisions proton–proton. Ce déficit indique que les quarks charmés connaissent une forte perte d'énergie dans l'état chaud et dense de la matière formée dans ces collisions.*

Andrea Dainese, INFN Padova, and **Francesco Prino**, INFN Torino, on behalf of the ALICE collaboration.

CONTROL THE SMALLEST LEAK
WITH OUR GAS DOSING LEAKVALVE

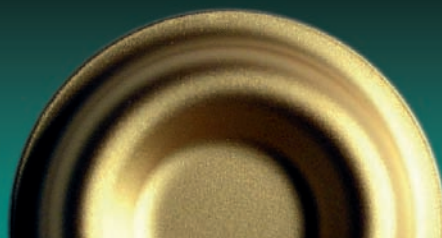

Silicon Drift Detector

No Liquid Nitrogen
Easy to Use

Solid State Design
Low Cost

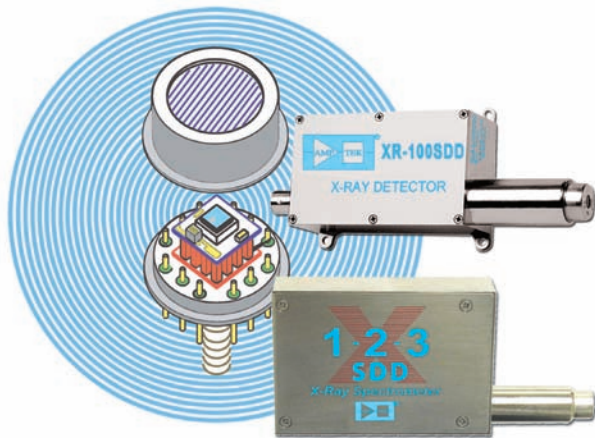

XR-100SDD X-Ray Detector and X-123SDD Complete X-Ray Spectrometer with X-ray detector and preamplifier, digital pulse processor, MCA, and power supply

SUPER SDD

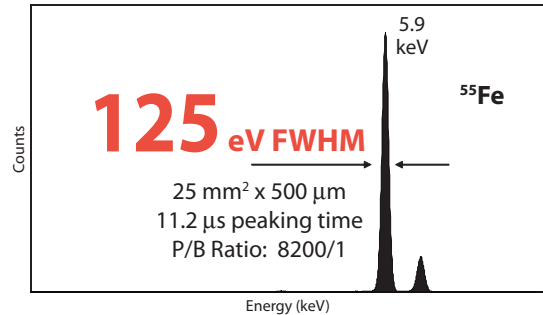

Please see web site for vacuum applications

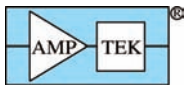

AMPTEK Inc.

E-mail: sales@amptek.com

www.amptek.com

Wide-Band Current Monitor



Pearson Electronics designs and manufactures custom Current Monitors for use in the beam tube, and large aperture clamp-on Current Monitors applied outside the beam tube.

Pearson Monitors measure sub-milliamp currents. Pulse rise times as fast as 1.5 nanoseconds can be viewed accurately. Many clamp-on and fixed aperture models are in stock and available for immediate delivery.

Contact Pearson Electronics for application information.

Pearson Electronics

4009 Transport St. Palo Alto, CA 94303 USA
Telephone: (650) 494-6444 FAX (650) 494-6716
www.pearsonelectronics.com



Measuring magnetic field transients?

The Fast Digital Integrator FDI2056 is the world's fastest and most sensitive voltage integrator.

For the first time it is possible to measure fast, low-level magnetic field disturbances such as eddy currents in a switched magnet.

A complete and upgradable solution for your most exacting magnetic measurements.

Now it's possible!
Designed at the CERN



www.metrolab.com

METROLab
Magnetic precision has a name

Silicon sensors go 3D

The first upgrade of the pixel system in the ATLAS experiment will incorporate radiation-hard 3D silicon detectors designed by a team of physicists and engineers who worked in conjunction with processing laboratories to move rapidly from R&D to production.

Three-dimensional silicon sensors are opening a new era in radiation imaging and radiation-hard, precise particle-tracking through a revolutionary processing concept that brings the collecting electrodes close to the carriers generated by ionizing particles and that also extends the sensitive volume to a few microns from the physical sensor's edge (*CERN Courier* January 2003 p23). Since the summer of 2011, devices as large as 4 cm² with more than 100,000 cylindrical electrodes have become available commercially thanks to the vision and effort of a group of physicists and engineers in the 3DATLAS and ATLAS Insertable B-Layer (IBL) collaborations who worked together with the original inventors and several processing laboratories in Europe and the US. This unconventional approach enabled a rapid transition from the R&D phase to industrialization, and has opened the way to being able to use more than 200 such sensors in the first upgrade in 2014 of the pixel system in the ATLAS experiment.

Radiation effects

Silicon sensors with 3D design were proposed 18 years ago at the Stanford Nanofabrication Facility (SNF) to overcome the limitations of the poor signal-efficiency of gallium-arsenide sensors, a problem that affects silicon sensors after exposure to heavy non-ionizing radiation. The study of microscopic and macroscopic properties of irradiated silicon was, and still is, the subject of extensive studies in several R&D groups and has led to the identification of stable defects generated after exposure to neutral or charged particles. The presence of such defects makes the use of silicon as a detector challenging in the highly exposed inner trackers of high-energy-physics experiments. The studies have discovered that while some of these defects act as generation centres, others act as traps for the moving carriers generated by incident particles produced in the primary collisions of accelerator beams. The three most severe macroscopic consequences for silicon-tracking detectors that have been found concern linearly proportional increases in the leakage current and in the effective doping concentration with increasing fluence, as well as severe signal loss that arises from trapping.

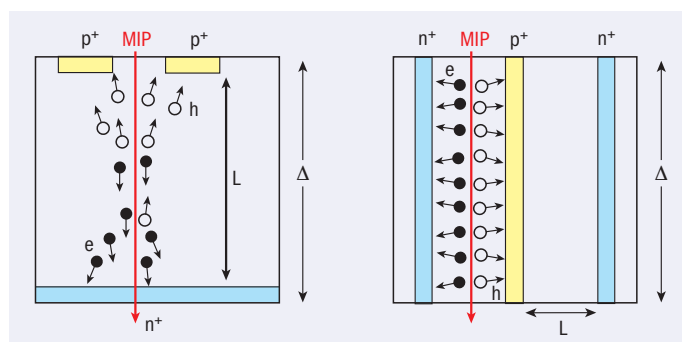

Fig. 1. Schematic cross-sections of (left) a planar sensor design and (right) a 3D sensor, showing how the active thickness (Δ) and collection distance, L , are decoupled in the latter.

However, other studies have found evidence that the spatial proximity of the p⁺ and n⁺ electrodes in the pin junction not only allows it to be depleted with a reduced bias-voltage but also that the highest useful electric field across the junction can be applied homogeneously to reduce the trapping probability of generated carriers after radiation-induced defects are formed. This leads to less degradation of the signal efficiency – defined as the ratio of irradiated versus non-irradiated signal amplitudes – after exposure at increasing radiation fluences.

What now makes 3D radiation sensors one of the most radiation-hard designs is that the distance between the p⁺ and n⁺ electrodes can be tailored to match the best signal efficiency, the best signal amplitude and the best signal-to-noise or signal-to-threshold ratio to the expected non-ionizing radiation fluence. Figure 1 indicates how this is possible by comparing planar sensors – where electrodes are implanted on the top and bottom surfaces of the wafer – with 3D ones. The sketch on the left shows how the depletion region between the two electrodes, L , grows vertically to become as close as possible to the substrate thickness, Δ . This means that there is a direct geometrical correlation between the generated signal and the amplitude of the depleted volume. By contrast, in 3D sensors (figure 1, right) the electrode distance, L , and the substrate thickness, Δ , can be decoupled because the depletion region grows laterally between electrodes whose separation is a lot smaller than the substrate thickness. In this case, the full depletion voltage, which depends on L and grows with the increase of radiation-induced space charge, can be reduced dramatically.

For the same substrate thickness – before or at moderate irradiation – the amount of charge generated by a minimum-ionizing particle is the same for both types of sensor. However, because the charge-collection distance in 3D sensors is much shorter – and high electric fields as well as saturation of the carrier velocity can be achieved at low bias-voltage – the times for charge

Detectors

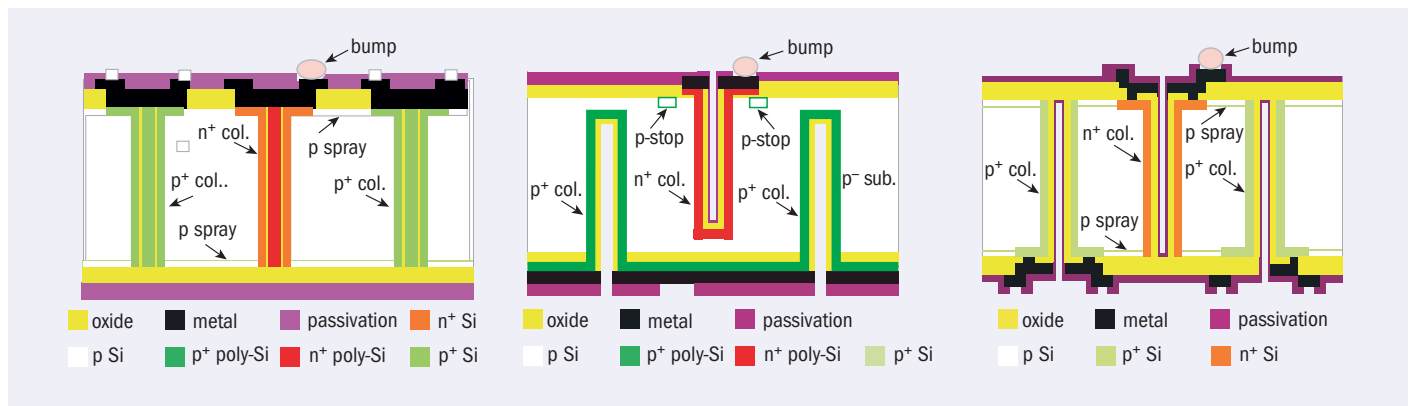

Fig. 2. Left: Full3D design with active edges, fabricated in Stanford and Oslo. Centre: 3D double-side with columns that partially pass through, as made by CNM. Right: FBK's 3D double-side design with columns that fully pass through.

collection can be much faster. Apart from making applications that require high speeds easier, this property can counteract the charge-trapping effects expected at high radiation levels. A 3D sensor reaching full depletion at less than 10 V before irradiation can operate at just 20 V and provide full tracking efficiency. After the heavy irradiation expected for the increased LHC luminosity, the maximum operational bias-voltage can be limited to 200–300 V. This has a crucial impact on the complexity of the biasing and cooling systems needed to keep the read-out electronics well below the temperatures at which heat-induced failures occur. By comparison, the voltages required to extract a useful signal when L increases, for example in planar sensors, can be as high as 1000 V.

These 3D silicon sensors are currently manufactured on standard 4-inch float-zone-produced, p-type, high-resistivity wafers, using a combination of two well established industrial technologies: micro-electro-mechanical systems (MEMS) and very large scale integration (VLSI). VLSI is used in microelectronics and in the fabrication of traditional silicon microstrip and pixel trackers in high-energy-physics experiments, as well as in the CCDs used in astronomy and in many kinds of commercial cameras, including those in mobile phones. A unique aspect of the MEMS technology is the use of deep-reactive ion etching (DRIE) to form deep and narrow apertures within the silicon wafer using the so-called “Bosch process”, where etching is followed first by the deposition of a protective polymer layer and then by thermal-diffusion steps to drive in dopants to form the n^+ and p^+ electrodes.

Two methods

Currently, two main 3D-processing options exist. The first, called Full3D with active edges, is based on the original idea. It is fabricated at SNF at Stanford and is now also available at SINTEF in Oslo. In this option, column etching for both types of electrodes is performed all through the substrate from the front side of the sensor wafer. At the same time, active ohmic trenches are implemented at the edge to form so-called “active edges”, whereas the underside is oxide-bonded to a support wafer to preserve mechanical robustness. This requires extra steps to attach and remove the support wafer when the single sensors are connected to the read-out electronics chip. An additional feature of this approach is that the columns and trenches are completely filled with poly-silicon (figure 2, left).

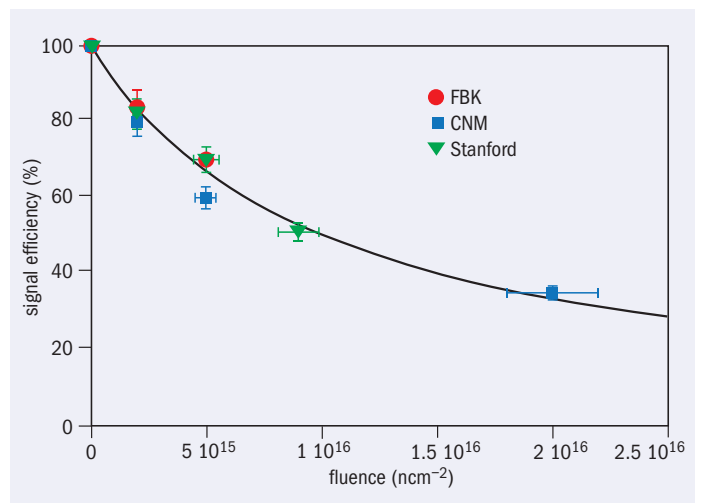

Fig. 3. Signal efficiency versus fluence from samples fabricated using the options described in the text. Stanford uses full 3D with active edges while CNM and FBK use double-side processing with partial and fully through columns, respectively. The point at the high fluence of 2×10^{16} was measured with 225 GeV pions at CERN (M Köhler et al. 2010 IEEE Trans. Nucl. Sci. **57** 2987).

The second approach, called double-side with slim fences is a double-side process, developed independently in slightly different versions by Centro Nacional de Microelectrónica (CNM) in Barcelona and Fondazione Bruno Kessler (FBK) in Trento. While in both cases junction columns are etched from the front side and ohmic columns from the back side, without the presence of a support wafer, in CNM sensors columns do not pass through the entire wafer thickness but stop a short distance from the surface of the opposite wafer-side (figure 2, centre). This was also the case for the first prototypes of FBK sensors but the technology was later modified to allow for the columns to pass through (figure 2, right).

While all of the remaining processing steps after electrode etching and filling are identical for a 3D sensor to those of a planar silicon sensor – so that hybridization with front-end electronics chips and general sensor handling is the same – the overall processing time is longer, which limits the production-volume capability for a single manufacturer at a given time. For this reason, to speed up

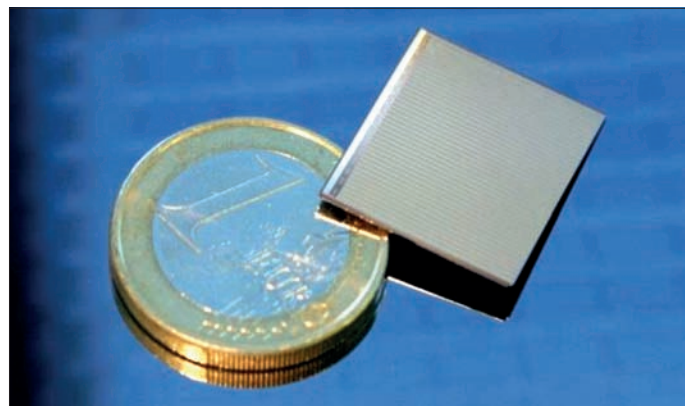
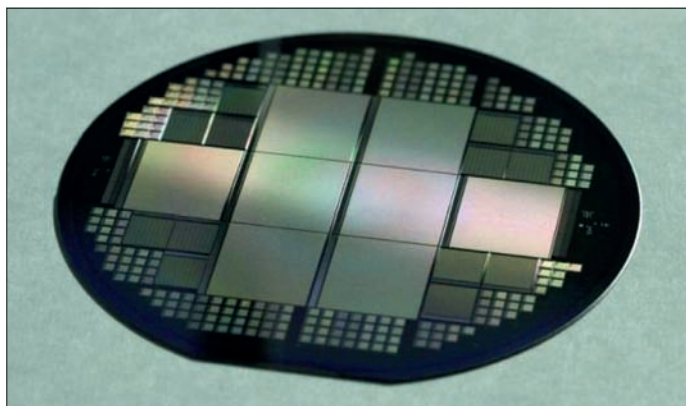

Fig. 4. A 3D wafer, left, with eight 3D chips as fabricated in all of the collaborating 3D processing facilities and, right, a single chip shown with a €1 coin for scale. These will record images of the production of the primary vertex in proton–proton collisions.

the transition from R&D to industrialization, the four 3D-silicon-processing facilities (SNF, SINTEF, CNM and FBK) agreed to combine their expertise for the production of the required volume of sensors for the first ATLAS upgrade, the IBL. Based on the test results obtained in 2007–2009, which demonstrated a comparable performance between different 3D sensors both before and after irradiation, the collaboration decided in June 2009 to go for a common design and joint processing effort, aiming at a full mechanical compatibility and equivalent functional performance of the 3D sensors while maintaining the specific flavours of the different technologies. Figure 3 demonstrates the success of this strategy by showing a compilation of signal efficiencies versus fluence (in neutron equivalent per square centimetre) of samples from different manufacturers after exposure to heavy irradiation. Their position fits the theoretical parameterization curve, within errors.

All of these 3D-processing techniques were successfully used to fabricate sensors compatible with the FE-I4 front-end electronics of the ATLAS IBL. FE-I4 is the largest front-end electronics chip ever designed and fabricated for pixel-vertex detectors in high-energy physics and covers an area of $2.2 \times 1.8 \text{ cm}^2$ with 26,880 pixels, each measuring $250 \times 50 \mu\text{m}^2$. These will record images of the production of the primary vertex in proton–proton collisions, 3.2 cm from the LHC beam in the IBL. Each 3D sensor uses two n electrodes tied together by an aluminium strip to cover the $250 \mu\text{m}$ pixel length. This means that each sensor has more than 100,000 holes.

Currently more than 60 wafers of the kind shown in figure 4 made with double-sided processing – which do not require support-wafer removal and have $200 \mu\text{m}$ slim fences rather than active edges – are at the IZM laboratory in Berlin, where single sensors will be connected with front-end electronics chips using bump-bonding techniques to produce detector modules for the IBL. Each wafer hosts eight such sensors, 62% of which have the required quality to be used for the IBL.

What's next?

Following the success of the collaborative effort of the 3DATLAS R&D project, the industrialization of active-edge 3D sensors with even higher radiation hardness and a lighter structure is the next goal in preparation for the LHC High-Luminosity Upgrade beyond 2020. Before that, 3D sensors will be used in the ATLAS Forward

Apart from applications in high-energy physics, 3D sensor technology has potential uses in medical, biological and neutron imaging.

Physics project, where sensors will need to be placed as close to the beam as possible to detect diffractive protons at 220 m on either side of the interaction point. Apart from applications in high-energy physics, where microchannels can also be etched underneath integrated electronics substrates for cooling purposes, 3D sensor technology is used to etch through silicon vias (TSV) in vertical integration, to fabricate active edge with planar central electrodes and has potential use in medical, biological and neutron imaging. The well defined volume offered by the 3D geometry is also ideal for microdosimetry at cell level.

• For more information about 3D sensors and the ATLAS IBL, see *3D Silicon Sensors: Design, Large area production and Quality Assurance for Pixel Detector Upgrades at the Large Hadron Collider NIMA-S-12 00289* and references therein.

Résumé

Des capteurs silicium 3D

Des capteurs silicium en trois dimensions sont en train d'ouvrir une nouvelle ère pour les détecteurs résistants aux radiations servant à la trajectographie des particules. Dans cette conception révolutionnaire, l'implantation des électrodes est rapprochée des porteurs de charge générés par les particules ionisantes. Le volume sensible est également étendu à une distance de quelques microns par rapport au bord du capteur. La première amélioration pour le système à pixels dans l'expérience ATLAS au CERN intégrera ce type de capteurs 3D. Ces éléments ont été conçus par une équipe de physiciens et d'ingénieurs, qui ont travaillé conjointement avec des laboratoires de traitement afin de passer rapidement de la R&D à l'industrialisation.

Cinzia Da Via, University of Manchester and 3DATLAS R&D collaboration.

DarkSide

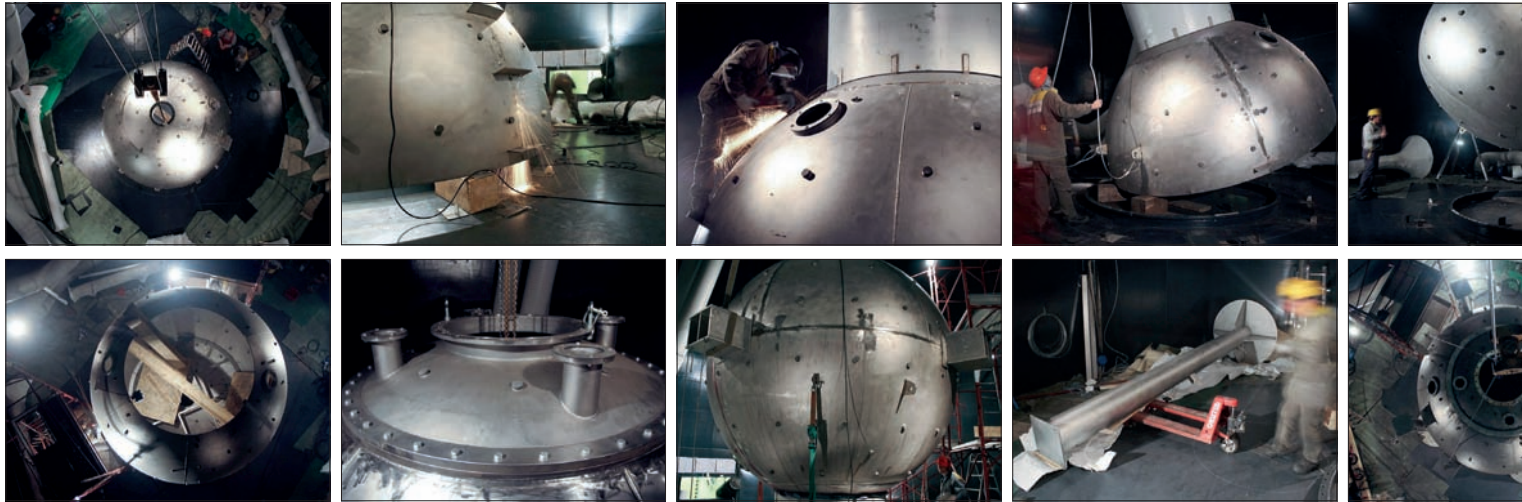

This sequence of photographs shows stages in the installation underground at the Gran Sasso National Laboratory of the 4-m diameter spherical

The DarkSide

A programme of experiments based on innovative detectors aims to take dark-matter detection to a new level of sensitivity.

Dark energy and dark matter together present one of the most challenging mysteries of the universe. While explaining the first seems to be within the reach of only cosmologists and astrophysicists, the latter appears to be accessible also to particle physicists. One of the most recent and innovative experiments designed for the direct detection of dark-matter particles is DarkSide, a prototype for which – DarkSide 10 – is currently being tested in the Gran Sasso National Laboratory in central Italy. The first detector for physics – DarkSide 50 – is scheduled for commissioning underground in December this year.

Astronomical observations suggest that dark matter is made of a new species of non-baryonic particle, which must lie outside the Standard Model. These particles must also be neutral, quite massive, stable and weakly interacting – hence the acronym WIMPs, for weakly interacting massive particles. One of the most promising candidates for a dark-matter particle is the neutralino, the lightest particle that is predicted in theories based on supersymmetry. However, constraints from recent measurements by experiments at CERN's LHC suggest that WIMPs may have a different origin.

A powerful way of detecting WIMPs directly in the local galactic halo is to look for the nuclear recoils produced when they collide with ordinary matter in a sensitive detector. However, WIMP-induced nuclear recoils are difficult to detect. Theory indicates

that they would be extremely rare, with some 10 events expected per year in 100 kg of liquid argon for a WIMP mass of 50 GeV/ c^2 and a WIMP–nucleon cross-section of 10^{-45} cm². They would also produce energy deposits below the order of 100 keV. Moreover, there are several potential background sources that can mimic the interaction between dark-matter particles and nuclei.

Sources of background

In a typical target, there are three main sources of background at energies up to tens of kilo-electron-volts: natural β and γ radioactivity, which induces electron recoils; α decays on the surface of the target in which the daughter nucleus recoils into the target and the α particle remains undetected; and nuclear recoils produced by the elastic scattering of background neutrons. This latter process is nearly indistinguishable from the signals expected for WIMPs and requires an efficient neutron veto in the apparatus.

DarkSide is a new experiment that uses novel techniques to suppress background sources as much as possible, while also understanding them well. The programme centres on a series of detectors of increasing mass, each making possible a convincing

claim for the detection of dark matter based on the observation of a few well characterized nuclear-recoil events in an exposure of several years. The design concept involves a two-phase, liquid-argon time-projection chamber (LAR-TPC) in which the energy released in WIMP-induced nuclear recoils can produce both scintillation and ionization. Arrays of

Several potential background sources can mimic the interaction between dark-matter particles and nuclei.

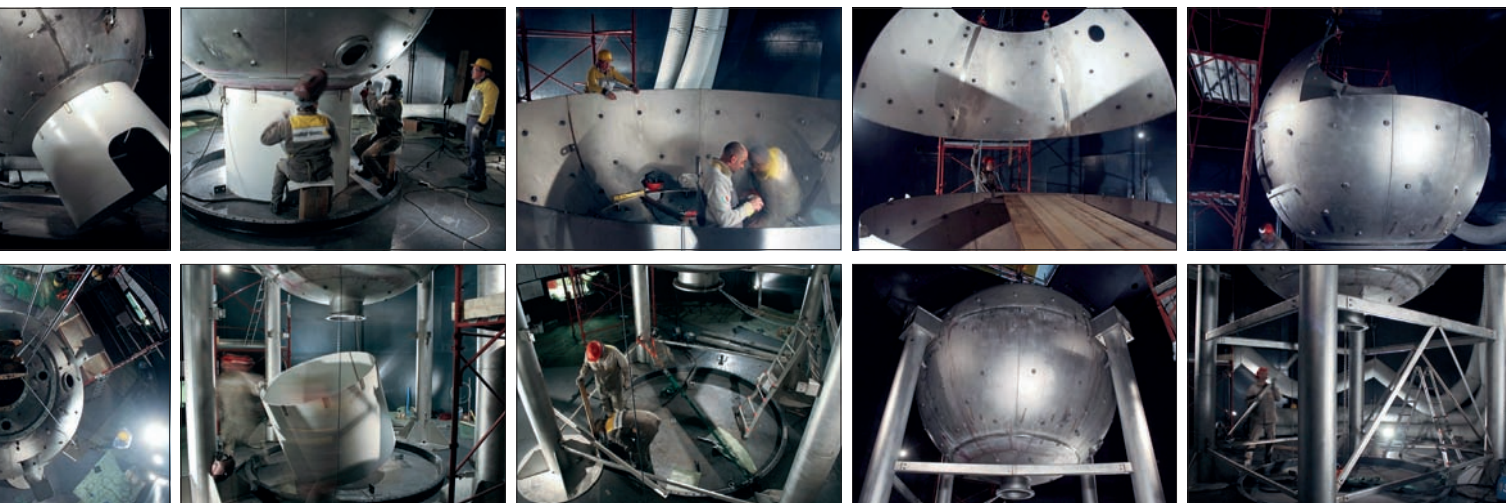

spherical vessel for the neutron veto for DarkSide-50 (see figure below). (Image credit: Yury Suvorov for the DarkSide collaboration.)

of Gran Sasso

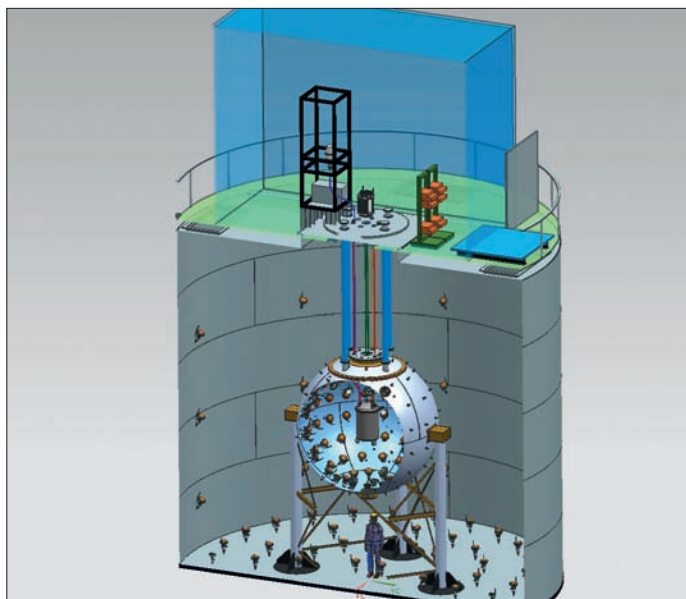

In DarkSide, dark-matter particles are detected in a two-phase liquid-argon TPC surrounded by a neutron veto of liquid scintillator (spherical vessel), inside 1000 m^3 of water to veto muons. (Image credit: DarkSide collaboration.)

photomultiplier tubes at the bottom and top of the cylindrical active volume detect the scintillation light. A pair of novel transparent high-voltage electrodes and a field cage provide a uniform drift field of about 1 kV/cm to extract the ionization produced. A reflective, wavelength-shifting lining renders the scintillation light from the argon (wavelength 128 nm) visible to the photomultipliers.

In a two-phase argon TPC, rejection of background comes from three independent discrimination parameters: pulse-shape analy-

sis of the direct liquid-argon scintillation signal (S1); the ratio of ionization produced in an event to scintillation, where the former is read out by extracting ionization electrons from the liquid into the gaseous argon phase, where they are accelerated and emit light through electroluminescence (S2); and reconstruction of the event's location in 3D using the TPC. The z co-ordinates for the event are determined by the time delay between S2 and S1, while the transverse co-ordinates are determined through the distribution of the S2 light across the layer of photomultiplier tubes.

As in other experiments searching for rare events, DarkSide's detectors will be constructed using materials with low intrinsic radioactivity. In particular, the experiment uses underground argon with extremely low quantities of ^{39}Ar , which is present in atmospheric argon at levels of about 1 Bq/kg as a result of the interaction of cosmic rays, primarily with ^{40}Ar . The DarkSide collaboration has developed processes to extract argon from underground gas wells, where the proportion of ^{39}Ar is low. A particularly good source of underground argon is in the Kinder Morgan Doe Canyon Complex in Colorado. The CO_2 natural gas extracted there contains about 600 ppm of argon. The DarkSide collaboration has operated an extraction facility at the Kinder Morgan site since February 2010; it has to date extracted some 90 kg of underground depleted argon and subsequently distilled 23 kg to about 99.99% purity. (The throughput is about 1 kg/day , with 99% efficiency.) Studies of the residual ^{39}Ar content of the distilled gas with a low-background detector at the Kimballton Underground Research Facility, Virginia, give an upper limit for the ^{39}Ar content equivalent to 0.6% of the ^{39}Ar in atmospheric argon.

It is not only the argon that has to have low intrinsic radioactivity. Nuclear recoils produced by energetic neutrons that scatter only once in the active volume form a background that is, on an event-by-event basis, indistinguishable from dark-matter \triangleright

Vacuum Feedthroughs for severe environments



IPT-Albrecht GmbH
 Waldweg 37
 77963 Schwanau / Germany
 Tel +49 - 7824 / 66 36 33
 Fax +49 - 7824 / 66 36 66
 Email: info@ipt-albrecht.de
www.ipt-albrecht.de

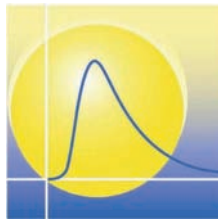

DarkSide

interactions. Neutrons capable of producing these recoil backgrounds are created by radiogenic processes in the detector material. In detectors made from clean materials, the dominant source of the radiogenic neutrons is typically the photodetectors, so ultralow background photodetectors are another important goal for DarkSide. A long-term collaboration with the Hamamatsu Corporation has resulted in the commercialization of 3-inch photomultiplier tubes with a total γ activity of around only 60 mBq per tube, with a further 10-fold reduction foreseen in the near future.

To measure and exclude neutron background produced by cosmic-ray muons, the DarkSide TPC will be deployed within an active neutron veto based on liquid scintillator, which will in turn be deployed within 1000 m³ of water in a tank 10 m high and 11 m in diameter, which was previously used in the Borexino Counting Test Facility at Gran Sasso. The liquid-scintillator neutron veto is a unique feature of the DarkSide design and is filled with ultrapure, boron-loaded organic scintillator, which has been distilled using the purification system of the Borexino experiment. The water serves as a Cherenkov detector to veto muons. Monte Carlo simulations suggest that with this combined veto system, the number of neutron events generated by cosmic-rays at the depth of the Gran Sasso Laboratory should be negligible, even for exposures of the order of tonne-years.

The DarkSide programme will follow a staged approach. The collaboration has been operating DarkSide-10, a prototype detector with a 10 kg active mass, in the underground laboratory at Gran Sasso since September 2011. This has been a valuable test bed during the construction of the veto system. It has allowed the light-collection, high-voltage and TPC field structures – and the data-acquisition and particle-discrimination analysis systems – to be optimized using γ and americium-beryllium sources. The first physics detector in the programme, DarkSide-50, should be deployed inside the completed veto system in the Gran Sasso Laboratory by the end of 2012. Looking forward to the second generation, upgrades to the underground argon plants are planned, and the nearly completed veto system has been designed to accommodate a DarkSide-G2 detector, which will have a fiducial mass of 3.5 tonnes.

● For more about DarkSide, see <http://darkside.lngs.infn.it>.

Résumé

Détecer la matière noire au Gran Sasso

Matière noire et énergie noire ensemble présentent l'une des plus grandes énigmes de l'Univers. DarkSide est une expérience innovante, très sensible, conçue pour la détection directe des particules de matière noire. Elle s'appuie sur une chambre à projection temporelle à argon liquide, dans laquelle l'énergie dégagée dans les reculs nucléaires générés par des particules de matière noire peut produire à la fois une scintillation et une ionisation. Un prototype – DarkSide 10 – est actuellement testé dans le Laboratoire national du Gran Sasso. Le premier détecteur de physique – DarkSide 50 – devrait être mis en service en souterrain au Gran Sasso en décembre.

Antonella Del Rosso, CERN.

**Raise your profile,
showcase your achievements.**

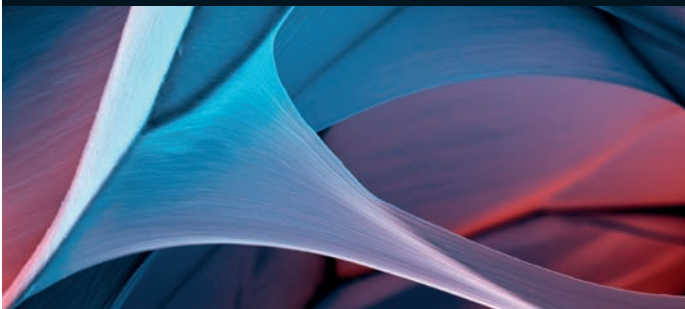

**The IOP Innovation Awards celebrate
excellence in physics-based innovation.**

To enter, and for more information and full terms and conditions, visit www.iop.org/innovation or e-mail innovation.awards@iop.org.

Image: Polystyrene insulating material, SEM Eye Of Science/Science Photo Library

IOP Institute of Physics

Edoardo Amaldi and the origins of ESA

In 1962, two organizations were founded to promote European efforts in space – four years after Edoardo Amaldi had first discussed his vision for a European space organization similar to CERN.

Towards the end of July 1958, at a house in the hills south-east of Rome, three Italian scientists discussed key ideas that were to form the foundations of the European Space Agency (ESA). Edoardo Amaldi, who had been instrumental in the establishment of CERN four years previously, was with Giorgio Salvini – whose house it was – and Gino Crocco, who was Goddard Professor of Jet Propulsion at Princeton in the US. During their conversation, the old friends discussed how European countries, in particular Italy, could become involved in space research. Only the previous October, the Soviet Union had opened up the space age with the launch of the first artificial satellite, Sputnik 1. This had been followed in January 1958 by Explorer 1, launched by the US. So what could Europe do?

As Salvini recalls, the conversation was “long and animated”. While Crocco was sceptical about what Italy could achieve, Salvini was more optimistic, and Amaldi, with all of his experience in setting up CERN, saw the case for an organization that would enable European countries to work together on research in space. In particular, Amaldi insisted on two points: that there should be no military involvement and that such an organization should be based on the successful model that had given rise to CERN.

At the end of the year, Amaldi wrote to Crocco at Princeton, describing the contacts that he had made in the meantime with some influential scientists. In the letter, Amaldi went on to describe how he thought the project to launch a “Euroluna” (“Euromoon”) satellite for scientific research should take shape. The letter makes clear his insistence that the underlying organization should not be linked to the military but should be purely scientific and based on the same principles as CERN.

As a starting point, Amaldi suggested that a small group of experts from the major European countries could prepare a plan for creating an appropriate organization. By early 1959 he had discovered an ally in an old friend, Pierre Auger, the French cosmic-ray

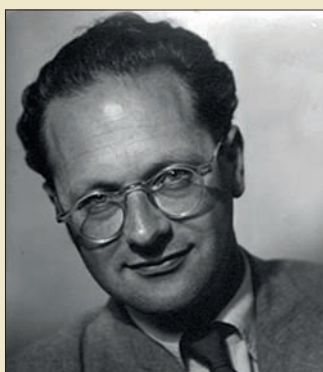

ESA's 3rd Automated Transfer Vehicle (ATV), right, named in honour of Edoardo Amaldi, left, was launched by an Ariane rocket on 23 March to take supplies to the International Space Station, 50 years after the birth of the organizations that gave rise to ESA. (Image credit: Left, E Amaldi Archives. Right, ESA.)

physicist who had also been involved in setting up CERN. By May, after several interactions with Auger, Amaldi had written the first draft of his paper, *Space Research in Europe*, with the aim of stimulating discussions on the formation of a European organization for space research. A French version, together with supportive comments from several countries, was distributed in December (Amaldi 1959).

In Amaldi's original vision, not only the development of the satellites – the “Eurolunas” – but also that of their launchers would be the responsibility of the organization, which would need experts in the technology and engineering of rockets as well as space scientists. The idea was to mirror CERN, which had accelerator physicists and engineers to build its own machines for the high-energy-physics community to use in scientific research. By collaborating at CERN,

Europe's scientists had access to accelerators that no country had the means to build on its own.

It soon became clear that this vision was not to be, albeit not to begin with. There was too much political and commercial interest surrounding the construction of rockets. Governments, in particular the British and French, began the negotiations that would separate the business of building launchers >

Amaldi insisted on two points: there should be no military involvement and the organization should be based on the model that had given rise to CERN.

Anniversary

from that of making the satellites for scientific research. On 29 March 1962 in London, seven countries – Belgium, France, Germany, Italy, the Netherlands, the UK and Australia (associate member) – signed the convention that created the European Launcher Development Organisation (ELDO). Three months later, on 14 June 1962 in Paris, Belgium, Denmark, France, Germany, Italy, the Netherlands, Spain, Sweden, Switzerland and the UK signed a different convention, in this case to create the European Space Research Organisation (ESRO).

The foundation of these separate bodies may have been counter to Amaldi's vision for an organization similar to CERN but they were the forebears of ESA, which was established in May 1975. With the formation of ESA, the science and the means to do it were brought into the same fold.

Amaldi's letter to Crocco, which is translated from Italian on the following pages, constitutes the first document in which a European space organization is mentioned. It is for this reason that 10 copies recently went into space on board a spacecraft taking essential supplies to the International Space Station (ISS). ESA's 3rd Automated Transfer Vehicle (ATV), named in honour of Amaldi, arrived at the ISS on 29 March 2012, exactly 50 years to the day of the convention to create ELDO being signed in London. Appropriately, the ATV had been launched by an Ariane rocket built by ESA. The copies of the letter will be signed by the astronauts and brought back to Earth by a Soyuz spacecraft. One will be given to CERN.

● Further reading

E Amaldi 1959 "Créons une organisation européenne pour la recherche spatiale", *L'Expansion de la Recherche Scientifique* 4 6; see also cdsweb.cern.ch/record/1435143/files/.

For more about the foundation of ESRO and ELDO, see:

J Krige and A Russo 2000 *A history of the European Space Agency 1958–1987* ESA SP-1235 I.

M De Maria 1993 *Europe in Space: Edoardo Amaldi and the inception of ESRO* ESA HSR-5.

Résumé

Amaldi et les origines de l'ESA

En décembre 1958, Edoardo Amaldi, qui avait joué un rôle-clé dans la création du CERN en 1954, envoyait à son collègue Gino Crocco, une lettre dans laquelle il donnait sa vision d'un programme européen de recherche scientifique dans l'espace. La lettre, reproduite ici, constitue le premier document dans lequel est mentionnée une organisation spatiale européenne. C'est pour cette raison qu'une copie du document a été envoyée dans l'espace, à bord d'un vaisseau spatial servant à approvisionner la Station spatiale internationale, 40 ans après la signature des conventions donnant naissance aux deux organisations qui devaient, ultérieurement, constituer l'Agence spatiale européenne.

16 December 1958
Prot. No 4674/A

Distinguished Prof.
Gino Crocco
College Road 74
PRINCETON – N.J.

Dear Gino,

After our discussion at Salvini's home in Rocca di Papa at the end of July, I thought over the possibility to develop an appropriate activity in Europe in the field of rockets and satellites. It is now very much evident that this problem is not at the level of the single states like Italy, but mainly at the continental level. Therefore, if such an endeavour is to be pursued, it must be done on a European scale as already done for the building of the large accelerators for which CERN was created.

The launch of one or more "Euroluna", performed by a dedicated European organization, would definitely be of the highest importance, both moral and practical, for all the nations of the continent.

With these ideas in mind, at the end of July I wrote a letter

to [Luigi] Broglio who replied, at the end of August, expressing his substantial agreement with the theoretical formulation of the problem but also a considerable scepticism with regards to the practical feasibility of an actual project.

During the Conference of Geneva, held in the first half of September, I had the opportunity to discuss it with [Isidor] Rabi who reacted very positively and stated that, if this would have developed further, he would have done everything possible for obtaining the support of the United States. Actually, himself being a representative of the United States in the NATO Science Committee, he thought that this could be the initiating body for this activity; however, I think this wouldn't be appropriate, as I shall explain later.

In November I spoke to [Harrie] Massey of [University College] London who, however, was rather sceptical; though this is the normal British attitude in front of any continental initiative.

At the beginning of December I spoke about the matter with [Francis] Perrin who was very interested and convinced and he promised me to look for some competent people in this specific field in France that could flag the problem.

The idea I have about this organization is that, in addition to the six EURATOM nations, Britain and the Scandinavian countries should participate in the manufacturing of satellites. Britain would at first limit itself to sending some observers and would probably show some resistance, but would certainly end up contributing substantially, would the project start taking shape.

It should, in my opinion, proceed as follows: some authoritative expert in the field (Broglio I hoped, but he seems not to have the necessary enthusiasm) should start flagging the problem and obtaining some level of participation of one or two experts of the largest European countries. Some Italian, French and German experts would be needed to start. These five or six people should prepare, within a few months, a plan of technical development containing :

- 1) a very well defined scope which should be so ambitious to be comparable with the targets that the USA and the USSR have set for themselves in this field, and in order to justify the European character of the endeavour;
- 2) an assessment of the cost and its time distribution;
- 3) an assessment of the specialized workforce;
- 4) a realistic time frame.

Such programme should be submitted to the governments for approval and for the resulting creation of the final organization which should be provided with the necessary resources.

In the case of CERN, things essentially developed as mentioned above; however, that case took advantage of the existence of UNESCO which, by calling the representatives of the governments to a first conference, played the role of the mother and nurse of CERN. I do not know who could be the mother and nurse of the new organization; according to Rabi this could be the "Science Committee" of NATO, but I believe that it wouldn't be the best mother for such organization. As a matter of fact, I think that it is absolutely imperative for the future organization to be neither military nor linked to any military organization. It must be a purely scientific organization open, like CERN, to all forms of co-operation both inside and outside the participating countries. I have the impression that all attempts to set up international organizations of a military nature have either failed or, if they didn't fail, present such characteristics that do not minimally satisfy even their own promoters and managers.

The high level start-up project should include :

- a) the construction of common European laboratories for solving the various major problems,
- b) a related research programme to be run in the participating countries.

Through either one or the other of these activities, the individual countries would have all the technologies at their disposal, and therefore their scientific-technical structure would be greatly strengthened. Such strengthening would bring, evidently, great advantages also in the military sector in case the defence activity would be necessary but it wouldn't make the realisation of the programme more difficult and complicated as would occur if the military, directly or indirectly, were the masters.

The financial problem, definitely irresolvable within the economy of one single country, could be solved in the context of the

European continent.

The problem of the specialized workforce constitutes a second difficulty, but I believe that this could be solved in such a project; this would have the double advantage of attracting the liveliest part of the new generation and making it possible to recover academics who work outside Europe.

I would like to ask you to think about what I wrote here and to reply, as soon as possible, to the following questions which, in a more or less direct manner and on different levels, are related to the project mentioned above :

- 1) I would like to know whether you are interested and whether you would like to take an active role or even the leading role in it. Personally I don't want to be involved in all of this except for launching the idea, at this stage, and later – in a few years – if the idea becomes reality, for participating in collecting the scientific data which can be obtained with this kind of activity;

- 2) I would like to know from you the names of the most competent and open persons in this field in Italy, France, Germany, Great Britain and in the Scandinavian countries. As I already told you, I contacted Broglio since July, but he seemed to be too sceptical for taking this route for the moment at least;

- 3) I would like to know which organizations, even of modest size, exist in Italy in this field and can provide an absolute guarantee of trust; for example, I came in contact with SAMI's engineer Salvatore but I have no idea of neither the value and competence of this person nor the robustness of the company. The seriousness of the people is a very fundamental issue; this venture is destined to fail, if people who are not sufficiently trustworthy slip into the initial organization committee.

Furthermore, I would like to have von Karman's address; Rabi asked me permission to speak to him about this and I agreed, but I don't know if he actually did it and whether this would be of any help. I would like to have your opinion on this subject too; nevertheless, I think that an authoritative person like him could, if favourable, have a considerable influence.

I believe that you will be very much surprised by this letter of mine; it is based on my experience with CERN: in 1952 only three or four persons in the whole of Europe believed in the possibility of creating CERN, but in 1958 the laboratories in Geneva have exceeded 800 workers, the first machine has started running giving first class scientific results and the second machine will work before mid-1960.

I believe that, if the European experts in the field of rockets and satellites start moving already now, they will be in a condition, together with the American and Russian groups, to contribute very substantially to the study of space by 1965.

I take this opportunity for sending you and your wife my best wishes, including among them the wish for a Euroluna before 1965.

E Amaldi

Since 1959

WIENER
Plein & Baus Elektronik

Werk für
Industrie-
elektronik
Nuklear-
elektronik
Regelungs-
technik



A Phoenix Mecano Company

Source for trouble free Power Supply Design

Mpod Multi Channel Power Supply

HIGH VOLTAGE UP TO 10kV — LOW VOLTAGE UP TO 120V
LOW NOISE: CLEAN LIKE A BATTERY!



STANDARD VERSIONS

- 10 vertical or 4 horizontal slots for LV and HV modules
- LV modules , 8 channels, 8V...120V ranges, (max. 50W/ch) floating. Extremely low output noise and conducted interference current
- HV modules up to 32 channels 500V...10kV ranges, floating or common ground.
NEW: High precision types with 50pA current resolution
- Modular construction with plug-in Controller / PS / fan, optionally Display
- Mpod Controller with Ethernet, CANbus, USB, Interlock, Status output
- Ethernet: TCP/IP with WEB interface, SMNP for OPC-server, EPICS and LabView
- Software compatible to WIENER PL5xx Power Supplies and 6000 Series Crates
- Rear side outputs optionally,

MIXED VERSION

Customizable divided into a Power Supply and a Crate part

- HV/LV cage with variable slot number
- Module cage separated, variable width for VME, cPCI, PXI backplanes
- Internal power supply feeds HV/LV modules and delivers independent voltages for backplanes, 3kW total power



MONITOR BOARD
also useable for
programming of HV and LV
modules manually





Fig. 1. The CO₂ cooling system (single panel, centre) for the AMS on board the International Space Station. (Image credit: NASA.)

CO₂ cooling is getting hot in high-energy physics

Cooling with carbon dioxide has benefits that are making it the preferred choice for the latest generation of silicon detectors.

The demand for efficient cooling systems that employ relatively small amounts of material – i.e. “low mass” systems – is becoming increasingly important for the new silicon detectors that are being used in high-energy physics. One solution that is gaining popularity is to use evaporative cooling with carbon dioxide (CO₂). Currently, two detectors are cooled this way: the Vertex Locator (VELO) in the LHCb detector; and the silicon detector of the orbiting AMS-02 space experiment on board the International Space Station. The CO₂ cooling system for VELO has been working since 2008 and the one on AMS has operated in space since May 2011. Both systems have

so far functioned without any major issues and both are stable at their design cooling temperature, –30°C for the VELO and 0°C for AMS.

The benefit of using CO₂ cooling is that it becomes possible to use much smaller cooling pipes compared with other methods used to cool particle detectors. The secret of CO₂ is based on the fact that evaporation takes place at much higher pressures than other two-phase refrigerants. In general, the volume of vapour created stays low while it remains compressed, which means that it flows more easily through small channels. The evaporation temperature of high-pressure CO₂ in small cooling lines is also more stable because the pressure drop has a limited effect on the boiling pressure. Savings in the mass of the cooling hardware in the detector when using CO₂ can be as high as an order of magnitude compared with other methods used to date.

The thermal performance of a cooling tube is based on two components: the temperature gradient along the tube caused by the changing boiling pressure, and the temperature gradient from ▷

Detectors

the wall of the tube into the fluid – which depends on the heat-transfer coefficient. It is difficult to compare different fluids with each other because the combination of these two performance indicators leads to different results for different tube geometries, heat-load densities and cooling temperatures. To show the benefits of CO₂, a specific case is plotted in figure 2 for a 1-m-long tube with a heat load of 500 W at –20°C. As efficiency in terms of the amount of matter in the cooling system is the driving factor in particle detectors, the cooling efficiency is plotted in terms of thermal conduction per cooling-tube volume. The benefit of using CO₂ is clear, especially in tubes with a small diameter. The general tendency for high-pressure fluids to have the best performances is also clear – only ammonia in this example seems to deviate from this trend.

Apart from its outstanding thermal performance, CO₂ is also a practical fluid. It is neither flammable nor toxic, although it will asphyxiate when released in larger quantities. In general, the small systems used in laboratories have smaller volumes than a standard fire extinguisher and are not dangerous if the CO₂ contents were to leak out. The larger systems used in detectors, however, must be designed with proper safety precautions. Some additional benefits of using CO₂ are the low utilization costs, the fact that it is a natural gas and, importantly, compatibility with sensitive instruments – contact with CO₂ is in general not damaging to electronics or other equipment. CO₂ does not exist as a liquid in ambient conditions and when released it is vented as the solid–gas mixture known as

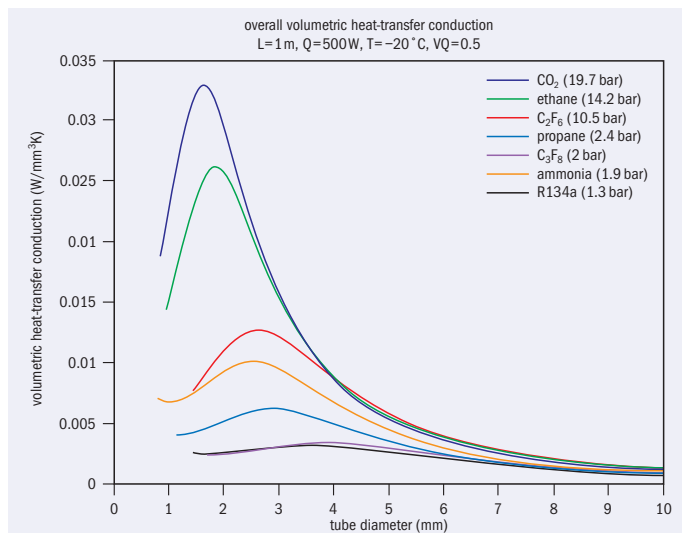

Fig. 2. Cooling performance curves for several fluids.

dry ice. CO₂ evaporates from its liquid phase between –56°C and +31°C and a practical range of application is from –45°C to +25°C.

For LHCb and AMS, a special CO₂-cooling method has been developed that is different from ordinary two-phase cooling systems. The best performance of the evaporative CO₂ method is achieved with an overflow of liquid, rather than evaporating the



METROLOGY AND POSITIONING

High performance hexapods for your precision positioning

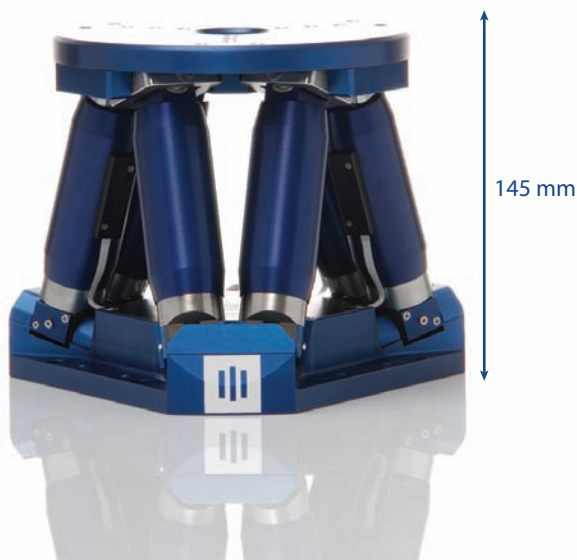

BORA Hexapod

HEXAPOD ADVANTAGES

- 6 degrees of freedom
- payload: 10 kg
- resolution: 0.1 μm / 2 μrad
- high stability & stiffness
- configuration of the rotation centre in software

For other hexapod sizes, consult us!

Contact: +33 (0)4 66 29 43 88 or info@symetrie.fr
 Discover our whole range: www.hexapod-system.com

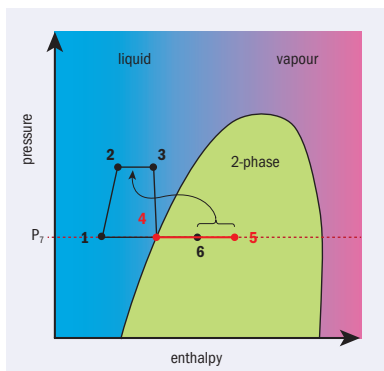

Fig. 3. The pressure–enthalpy diagram for a 2PACL cooling system.

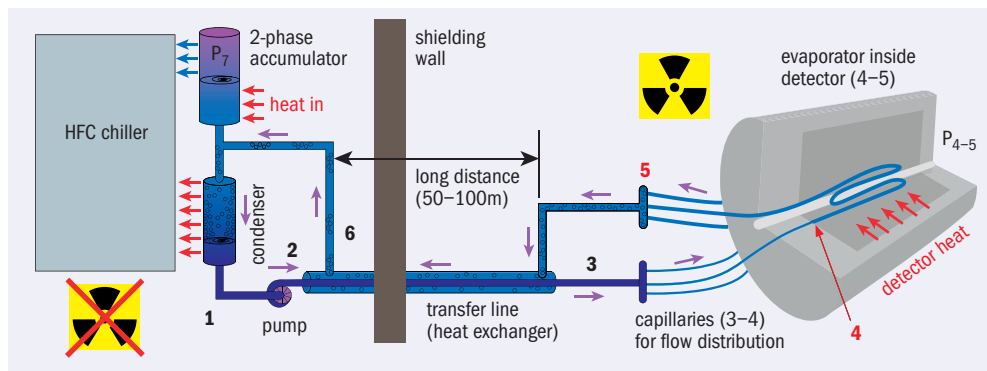

Fig. 4. The 2PACL concept as used in detector cooling. On the left is the accessible cooling plant; on the right, the inaccessible detector with only passive cooling piping. The numbers 1–6 refer to the node numbers in the pressure–enthalpy diagram of figure 2.

last drop. A liquid-pumped system with external cooling is preferable to a compressor-driven vapour system of the kind used in refrigerators. A big advantage is that a liquid-pumped CO_2 system is relatively simple, which is useful when integrating it into a complex detector. The CO_2 condensing can be done externally using a standard industrial cooler.

The method that has been developed for cooling detectors is called 2PACL, for 2-Phase Accumulator Controlled Loop. Accumulator control being a proven method in existing two-phase cooling systems for satellites, this method was initially developed for AMS by Nikhef in an international collaboration led by the Netherlands National Aerospace Laboratory, NLR. The novelty is precise pressure regulation with a vessel containing a two-phase CO_2 mixture. The benefit of using this system with detectors is that the cooling plant containing all of the active components can be set up some distance away. The cooling plant can be designed to be remote from the inaccessible detector, leaving only tubing of small diameter inside or near the detector.

Figure 3 shows the thermodynamic cycle for the 2PACL system in a pressure–enthalpy diagram – a useful representation of the cycle in evaporative-cooling systems. Figure 4 shows the 2PACL principle used in detectors, with the node numbers corresponding to those used in figure 3. For AMS, the external cooler was replaced by cold radiator panels mounted on the outside of the experiment (see figure 1, p29).

The 2PACL concept was also successfully applied by Nikhef for cooling the LHCb's VELO with CO_2 and it has become the baseline concept for future detectors that are under development. The pixel detectors for ATLAS and CMS phase-1 upgrades are being designed to be cooled by the 2PACL CO_2 system and the same technology is also under consideration for the silicon detectors for the full phase-2 upgrades for ATLAS and CMS. Elsewhere, CO_2 cooling is under development for the Belle-2 detector at KEK and the IL-TPC detector for a future linear collider. Industrial hi-tech applications are also showing interest in the technique as an alternative cooling method.

Currently, CERN and Nikhef are developing small, laboratory CO_2 coolers for multipurpose use (figure 5). The units, called TRACI, for Transportable Refrigeration Apparatus for CO_2 Investigation, are relatively low cost and optimized for a wide operating



Fig. 5. TRACI prototypes for multipurpose CO_2 cooling under construction at CERN. (Image credit: Kamil Cichy.)

range and user-friendly operation. Five prototypes have been manufactured and the hope is that results from these units will lead to a design that can be outsourced for manufacture by external companies. In this way, the many research laboratories investigating CO_2 for their future detectors could be supplied with test equipment.

Résumé

Du dioxyde de carbone pour refroidir

La nécessité de systèmes de refroidissement efficaces employant des quantités relativement faibles de fluide est de plus en plus impérative pour les détecteurs au silicium utilisés en physique des hautes énergies. Une solution qui semble prometteuse consiste à utiliser un refroidissement par évaporation au dioxyde de carbone (CO_2). Actuellement deux détecteurs sont refroidis par ce procédé : le localisateur de vertex (VELO) dans le détecteur LHCb et le détecteur au silicium de l'expérience AMS-02, à bord de la Station spatiale internationale. On prévoit maintenant des systèmes similaires pour refroidir des versions améliorées des détecteurs à pixels d'ATLAS et de CMS.

Bart Verlaart, Nikhef and CERN.

Faces & Places

INDUSTRY

CERN supports new centre for business incubation in the UK

To bridge the gap between basic science and industry, CERN and the Science and Technology Facilities Council (STFC) have launched a new business-incubation centre in the UK. The centre will support businesses and entrepreneurs to take innovative technologies related to high-energy physics from technical concept to market reality.

The centre, at STFC's Daresbury Science and Innovation Campus, follows the success of a business-incubation centre at the STFC's Harwell campus, which has run for 10 years with the support of the European Space Agency (ESA). The ESA Business Incubation Centre (ESA BIC) supports entrepreneurs and hi-tech start-up companies to translate space technologies, applications and services into viable non-space-related business ideas.

The CERN-STFC BIC will nurture innovative ideas based on technologies developed at CERN, with a direct contribution from CERN in terms of expertise. The centre is managed by STFC Innovations Limited, the technology-transfer office of STFC, which will provide successful applicants with entrepreneurial support, including a dedicated business champion to help with business planning, accompanied technical visits to CERN as well as access to scientific, technical and



John Womersley, CEO of STFC, left, and Steve Myers, CERN's director of accelerators and technology, at the launch of the CERN-STFC Business Incubation Centre on the Daresbury Science and Innovation Campus. (Image credit: STFC.)

business expertise from STFC and CERN. The selected projects will also receive a

total funding of up to £40,000 per company, provided by STFC.



On 27–28 March some 30 French companies presented their latest technological advances during the industrial exhibition "France at CERN", which featured products and technologies related to activities at CERN. Here, Nicolas Niemichinow, permanent representative of France to the United Nations Office and other international organizations in Geneva, tours the exhibition with, to the right, Rolf Heuer, director-general of CERN, Frédéric Bordry, head of the technology department at CERN, and Fabrice Lelouvier, director of the Swiss branch of UBIFRANCE, the French Agency for International Business Development, responsible for promoting French technologies and know-how abroad. The event was sponsored by the French subsidiary of RS Components.

AWARDS

Trần Thanh Vân receives the AIP's Tate Medal

The American Institute of Physics (AIP) has given its 2011 John Torrence Tate Award for International Leadership in Physics to Jean Trần Thanh Vân. He receives the award “in recognition of his role spanning more than four decades in bringing together the community of physicists across national and cultural borders through the Rencontres de Moriond and Rencontres de Blois, and for his tireless efforts to build a modern scientific community in Vietnam”.

Trần Thanh Vân was born in Dong Hoi, Vietnam, and spent his childhood in a country ravaged by war. At the age of 13 he left his family to study in Huế and at the age of 17 took an opportunity to go to university in France, ultimately gaining a doctorate in particle physics from the University of Paris in 1963. While working on his thesis, he perceived a lack of communication between theoreticians and experimentalists in the same field so, in 1966, he created with a few colleagues a series of meetings – “Rencontres” – to promote exchange and collaboration in a



Jean Trần Thanh Vân, left, with François Englert, at the 2012 Rencontres de Moriond, earlier this year. (Image credit: J-M Frère.)

friendly and convivial atmosphere.

The Rencontres de Moriond meetings went on to gain international stature as a venue for presenting new discoveries (*CERN Courier* July/August 2005 p21). Held in winter in the French Alps, the meetings provide plenty of time for discussion, including breaks to share physical exercise in beautiful surroundings. Another important feature is the prominence given to young scientists,

with results presented directly by those responsible for the analysis. Many prominent physicists have given their first international presentation at these Rencontres. In addition, Trần Thanh Vân has at all times promoted broad international collaboration; even in the most difficult times of the Cold War, he ensured that scientists from all countries, including the USSR and the Eastern block, could participate.

In 1981, Trần Thanh Vân started the Moriond Astrophysics series, which is held in parallel with the particle-physics Rencontres to maximize interactions between the two disciplines. In this spirit of cross-fertilization, a new series, the Rencontres de Blois, was initiated in 1989, with the rich architecture of the Loire valley providing a cultural backdrop. In 1993, with the opening of Vietnam to the western world, the first Rencontres du Vietnam were held to enable the Vietnamese scientific community – after years of isolation – to develop contacts and exchanges with foreign colleagues.

Alain Aspect receives Albert Einstein Medal

In a ceremony on 10 May, Alain Aspect received the Albert Einstein Medal 2012, awarded by the Albert Einstein Society, Bern. The medal, which is to honour extraordinary achievements related to Einstein's legacy, is awarded to Aspect for his fundamental contributions to quantum



Alain Aspect holds up his award. (Image credit: H Friedli / Albert Einstein Society.)

physics, in particular for his experimental tests of Bell's inequalities. Aspect is

research director at the Centre National de la Recherche Scientifique (CNRS) as well as a professor at the Optics Institute Graduate School and at École Polytechnique, Paris. He leads the Atomic Optics Group at the Charles Fabry Laboratory in Palaiseau (Optics Institute Graduate School/CNRS/Université Paris-Sud).

The Albert Einstein Society was founded in Bern in 1977 and the first medal was awarded to Stephen Hawking in 1979, the centenary of Einstein's birth. The society also maintains Einstein's former flat, at 49 Kramgasse in Bern, as a commemoration site open to the public.

London's Royal Society elects new fellows

Tejinder (Jim) Virdee has been elected as a fellow of the Royal Society in London. Virdee, who is professor at Imperial College London, is distinguished primarily for the design, construction and exploitation of the CMS experiment at the LHC. He originated the concept of CMS with four colleagues around the year 1990 and went on to be spokesperson for the collaboration



Jim Virdee, now FRS. (Image credit: STFC.)

from 2007 until 2009, during the final commissioning and first stage of data-taking.

Other new fellows announced on 19 April include Christopher Hull, who is also a professor at Imperial College. He has been elected for his imaginative and influential contributions to quantum gravity, specifically superstring and supergravity theories. In addition, cosmologist Brian Schmidt, of the Australian National University, becomes the 83rd Nobel Laureate to join the ranks of the society's fellows and foreign members. As leader of the High-z Supernova Search, he shared the 2011 Nobel Prize in Physics for the discovery of the accelerating expansion of the universe.

Faces & Places

CORNELL

Maury Tigner takes a back seat

Maury Tigner has retired as Head of the Cornell Laboratory for Accelerator-based ScienceS and Education (CLASSE) as of December 2011.

Maury's work and contributions to accelerator physics and engineering have spanned five decades, having begun in 1959 with the nearly single-handed design and construction of a 240 MeV electron storage-ring for his doctoral thesis at Cornell under Robert Wilson. His career has since covered critical developments at Cornell, the beginnings of the HERA electron-proton collider at DESY, the core of the design effort for the Superconducting Super Collider and vital help for Chinese high-energy physics – all while being a prime mover of fundamental developments in superconducting RF technology. He also served as chair of the Machine Advisory Committee for the LHC at CERN and is co-editor of the widely used *Handbook of Accelerator Physics and Engineering*.

Throughout his career, Maury's drive and vision have influenced the direction of accelerator development and inspired students and colleagues. An early example is the seminal paper he published in 1965 in *Nuovo Cimento* in which he envisioned colliding linac beams as an alternative to storage rings for studying electron-electron collisions. Here he already invoked the benefits of superconductivity and lowering the operating power by using energy recovery.

Soon after the discovery of J/ψ, the Cornell laboratory proposed to the National Science Foundation the conversion of its synchrotron facility into an electron-positron collider with 8 GeV beams. After approval in late 1977, Maury was put in charge of construction of the Cornell Electron Storage Ring (CESR). Electrons were stored on 2 April 1979, followed by positrons on 28 May and the CLEO and CUSB experiments started data-taking in October the same year. The fortunate timing of the discovery at Fermilab of the Y states in the "sweet spot" of CESR's energy range provided the fuel for several decades of highly productive B physics. CESR's colliding-beam operation for the CLEO collaboration ended in March 2008 and the Cornell High Energy Synchrotron Source (CHESS) moved from mainly parasitic operation to become a prime user of CESR. At the same time, the CESR Test Accelerator (CesrTA) programme was formed to explore



Maury Tigner and colleagues in the early days of CESR at Cornell. His drive and vision have influenced the direction of accelerator development throughout the world. (Image credit: Cornell.)

beam-dynamics effects related to the design options for damping rings for a future International Linear Collider and it shared, with CHESS, the operation of CESR.

Under Maury's leadership Cornell tested the first superconducting cavities in a storage ring. The Cornell cavity design was adopted for the recirculating linac in the Continuous Electron Beam Accelerator Facility, at Jefferson Lab. This facility currently runs 350 such cavities at an average gradient close to 7 MV/m to provide beams at 6.5 GeV. Throughout the decade up to his retirement, Maury devoted much of his time to laying the groundwork for a proposal for a full energy-recovery linac operating at 100 mA beam current and 5 GeV beam energy. Such a machine will be a monument to his long career, combining his 1965 concept for colliding linac beams with the superconducting RF that has been his passion, and turning his vision into a laboratory at the forefront of science.

Maury has received many awards, including, fittingly, the Robert R Wilson Prize of the American Physical Society, which cited Maury's "notable contributions to the accelerator field as an inventor, designer, builder and leader, including early pioneering developments in superconducting radio-frequency systems," as well as his leadership in the construction of CESR.

MEETINGS

The **8th Patras Workshop on Axions, WIMPs and WISPs** will be held on 18–22 July at the Hyatt Regency in Chicago. This is the first time that this workshop series is visiting the US and it continues the tradition of attracting young scientists together with experimental and theoretical leaders in the field. The format includes plenary sessions only, allowing ample time for discussion. This year, participants will be able to spend one day at nearby Fermilab. For further information, see <http://axion-wimp.desy.de>.

QCD 12, the 16th Montpellier International Conference on Quantum Chromodynamics, will take place on 2–7 July in Montpellier. The meeting, which traditionally involves equal mixtures of experimentalists and theorists, and of young and senior physicists, will cover different aspects of QCD – perturbative, non-perturbative and the interface with other fields. For further information, see www.lpta.univ-montp2.fr/users/qcd/qcd2012/qcd12/Welcome.html.

NEW PRODUCTS

Murata Power Solutions has announced the UWQ series of isolated open-frame 204 W DC/DC converters packaged in a through-hole-mount quarter-brick format. Just 58.4 × 36.8 × 11.7 mm in size and with an efficiency of 92%, the UWQ series has a 4:1 input voltage range of 18–75 VDC around a nominal 48 VDC input. It provides a single output voltage of 12 VDC up to 17 A of current with a line regulation of +/-1% and load regulation of +/-1.5. For further information, contact Sarah Smith, tel +44 1908 615 232, e-mail sarah.smith@murata-ps.com or visit www.murata-ps.com.

Pfeiffer Vacuum has introduced the Adixen ASI 30 fully integratable modular helium-leak detector. The ASI 30 features 3G technology and reduced maintenance requirements. Its small, modular design is optimized for minimum space. The interface options include RS232, Ethernet, Profibus or USB. Pfeiffer has also announced two new gas-analysis systems, the Sputter Process Monitor SPM 220 and the High Pressure Analyzer HPA 220. Both systems are based on the mass spectrometer PrismaPlus in combination with a dry compressing HiPace turbo pumping station and both are available in mass ranges of 1–100 and 1–200 amu; the HPA 200 is also available for 1–300 amu. For details, visit www.pfeiffer-vacuum.com.

JINR

Kadyshevsky celebrates 75 years

Vladimir Kadyshevsky, scientific leader at the Joint Institute for Nuclear Research (JINR) celebrated his 75th birthday on 5 May.

Kadyshevsky has been with JINR since 1962, when he joined the Laboratory of Theoretical Physics after graduating from the Lomonosov State University in Moscow in 1960. He was elected director of the Laboratory of Theoretical Physics of JINR in 1987 and was director of JINR in the years 1992–2005. Since 2006 he has served as scientific leader, contributing a great deal to the development of the main research trends of JINR as an international intergovernmental scientific organization – and consolidating its reputation in the world.

In theoretical physics, Kadyshevsky's name is associated with the covariant Hamiltonian representation of quantum field theory on which he started work in the early 1960s. This led to a 3D integral equation for



Vladimir Kadyshevsky, scientific leader. (Image credit: JINR.)

the relativistic scattering amplitude, which is now known as the Kadyshevsky equation, and to new methods for solving finite

difference equations. His studies in this field, acknowledged by other scientists, anticipated the research on non-commutative geometry of the 1990s.

In 1977–1978, Kadyshevsky was head of the group of Soviet physicists who worked at Fermilab and in the years 1983–1985 he led research on DELPHI at CERN as part of JINR's contribution to the experiments at the Large Electron–Positron collider.

Kadyshevsky successfully combines his various scientific and science-organizational activities with training young scientists.

For many years he has been a lecturer in theoretical physics at the Lomonosov State University in Moscow and is currently head of elementary particle physics. He was one of the initiators of the university in Dubna that was opened in 1994 with the name of “The International University of Nature, Society and Man”, and he was its president from 1995 until 2009.



PUBLICATIONS

The latest vehicle for accelerating news

A new online publication – *Accelerating News* – is now available for the particle-accelerator community. Sponsored by four accelerator projects, it showcases project news and results, as well as events and articles of interest to those working in the accelerator field. The site's sponsors – EuCARD, TIARA, HiLumi LHC and EUROnu – are all projects co-funded by the European Commission under the 7th Framework Programme.

Issue 1, out now, highlights how the EuCARD accelerator R&D project is promoting not only its endeavours, but also the applications of accelerators in nuclear power and in medical-isotope production. The issue also outlines the EUROnu design study of future high-intensity neutrino-oscillation facilities, explains the latest

VISITS



Håkan Ekengren, Swedish state secretary to the minister for enterprise, left, was welcomed to CERN on 6 March by **Sergio Bertolucci**, CERN's director for research and scientific computing. The visit included tours of the ATLAS Visitor Centre, the ATLAS underground area, the ALICE underground area, the CLIC Study Facility and the Computer Centre.

On 8 March, Czech deputy minister, research and higher education section, ministry of education, youth and sports, **Ivan Wilhelm**, left, and **Katerina Sequensová**, ambassador, permanent representative of the Czech Republic to the United Nations Office and other international organizations in Geneva, visited the CERN Control Centre, where **Giulia Papotti**, right, of the Beams Department explained the operation of the accelerator complex. The deputy minister also toured the ATLAS Visitor Centre.



results from the TIARA project – including a new world record for vertical emittance – and describes developments in the High Luminosity LHC design study (*CERN Courier* March 2012 p19).

The newsletter will be published quarterly – spring, summer, autumn and winter – and Issue 2 is due out soon. To view the current issue and to receive future issues by e-mail, visit www.acceleratingnews.eu.

Faces & Places

OBITUARIES

Patrice Payre 1950–2010

Patrice Payre, experimental physicist, passed away after a heart attack in December 2010.

Patrice was born in Brittany on 19 March 1950. He obtained his PhD at the Institut de Physique Nucléaire, Orsay, on trigger studies of multimMuon production in the muon beam at CERN's Super Proton Synchrotron. This work contributed to the proposal of what would later become the European Muon Collaboration (EMC) experiment. On joining the Centre National de la Recherche Scientifique he continued his work on the EMC experiment at the Laboratoire d'Annecy-le-Vieux de Physique des Particules (LAPP), where he made major contributions to the measurement of the structure-functions of iron and played a leading role in the demonstration of the so-called "EMC effect".

In 1983, Patrice was among the first researchers to join the newly created Centre for Particle Physics of Marseilles (CPPM), where he became involved in the ALEPH collaboration at the Large Electron-Positron (LEP) collider at CERN. He was responsible for the construction and maintenance of the gas recirculation system of the electromagnetic calorimeter. This system was based on what was at the time a new approach, using a network of distributed microprocessor-controlled stations supervised by an innovative artificial intelligence system. For the subsequent Phase 2 of the LEP collider, he made major contributions to the mechanical design and construction of the upgraded ALEPH vertex detector.

In 1995, Patrice went on to contribute



Payre in the lab. (Image credit: CPPM.)

to the pioneering efforts to establish the field of neutrino astronomy, making feasibility studies for the construction of the ANTARES deep-sea neutrino telescope in the Mediterranean Sea, offshore from Toulon. Participating in the site evaluation studies, he also led the development of the first software for the muon track-reconstruction. Patrice was also the driving force behind the design and implementation of the timing system used to synchronize the

large number of clocks distributed within the detector.

More recently, inspired by the interdisciplinary potential of underwater observatories, Patrice fostered the development of innovative technologies to monitor the deep-sea environment. These included real-time sampling of dissolved oxygen and techniques to operate electronics in oil at high pressures.

Patrice's independent spirit and great curiosity often led him to unexplored fields, paving the way for others to follow. His great passion for his work was characterized by his inventive solutions to the technological challenges he faced. His talents in both hardware and software benefitted from his careful approach and meticulous attention to detail.

He was a brilliant researcher who was open minded, discrete and generous with his colleagues. With humour and patience he transmitted his love of experimental physics to many generations of students and young researchers. He was also a man of great generosity in everyday life – a true gentleman. He is sorely missed by family, friends and colleagues.

- A special half-day seminar in memory of Patrice Payre will be held at the CPPM on 15 June, with talks on the experiments he took part in. For further information, see <http://marwww.in2p3.fr/sommaire.php3?lang=fr> or e-mail hommage@cppm.in2p3.fr. Messages and dedications about Patrice are also welcome at hommage@cppm.in2p3.fr.

- *His colleagues and friends.*

Siegfried Wolff 1939–2012

Siegfried Wolff, a well known expert on superconducting magnets, passed away at the age of 73 on 13 March after a long illness.

After obtaining his physics diploma in 1965 Wolff joined the bubble-chamber group at DESY as a technical physicist. He made substantial contributions to the successful operation of liquid-hydrogen and deuterium bubble chambers and in 1969 obtained his PhD at the University of Hamburg with a thesis on the formation and growth of bubbles in such chambers.

In the early 1970s, when the electron-

positron storage ring DORIS was constructed, Wolff moved to magnet design and measurement. He designed the compensation coils for an experiment at DORIS that was equipped with a superconducting solenoid, and the magnetic measurements for the larger storage ring PETRA were carried out under his leadership. When the proton-electron collider HERA was proposed, he joined the task force that was set up by Bjørn Wiik to design and construct the superconducting accelerator magnets of the proton ring.

Wolff spent a sabbatical at Fermilab in the period 1979–1980 where he worked in the superconducting-magnet group and acquired a thorough knowledge of the design principles and construction of the superconducting dipoles and quadrupoles for the Tevatron. Once back at DESY, he made important contributions to the design of the HERA dipoles and quadrupoles, and his group of engineers and technicians built a number of prototype dipoles that performed well and exceeded the design field of 5 T.

In 1984 a radical design change was

proposed to increase the field capability of the magnets and improve their quench safety. The warm-iron yoke of the Tevatron-like design was to be replaced by a cold-iron yoke directly surrounding the aluminium-collared coil. Within record time Wolff's group built a short prototype of the new dipole, which reached a field of 6 T without training. The new magnet concept proved extremely successful in the industrially produced HERA magnets and had a strong impact on the design of the LHC magnets. During the construction phase of HERA, Wolff and his group performed the electric and cryogenic installation of the HERA proton ring.

When HERA was completed, Wolff became head of the cryogenics group at DESY. He and his group contributed a great deal to the successful R&D on superconducting cavities with accelerating fields above 25 MV/m, which was carried out by the international TESLA collaboration. Wolff's group was also involved in the cryostat construction and provided the cryogenics for the TESLA Test Facility linac, which was later upgraded to the free-electron laser, FLASH.

Wolff was an internationally recognised expert in superconducting magnets. He was

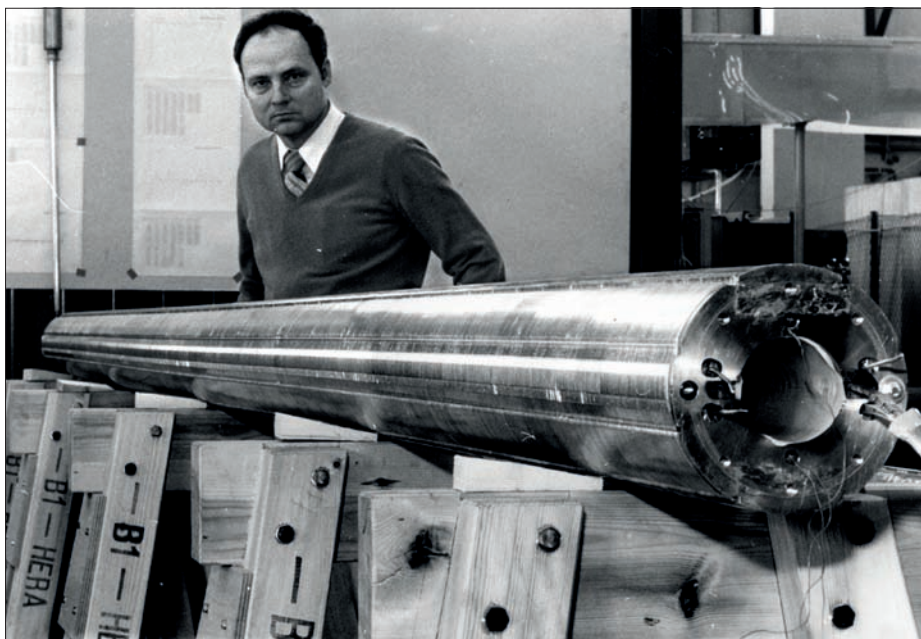

Siegfried Wolff with a HERA dipole coil in 1983. (Image credit: DESY.)

a member of various advisory committees, among them the LHC Machine Advisory Committee, and he was co-author of a book on superconducting accelerator magnets. He will be remembered by his friends

and colleagues for his great technical competence, his fairness and reliability, and his willingness to accept responsibility for demanding projects.

● *Friends and colleagues at DESY.*

Pedro Waloschek 1929–2012

Pedro Waloschek, a senior scientist at DESY and a science writer, passed away on 8 March.

Pedro Waloschek was born in 1929 in Dresden. He had Austrian nationality and was forced to emigrate with his parents to Argentina in 1939 because of persecution by the Nazi regime. He obtained his PhD in 1954 at the University of Buenos Aires and then came back to Europe to work on cosmic radiation and high-energy physics in Goettingen and Bern. From 1957 he worked in Italy, first in Bologna with Gianni Puppi, where he led a bubble chamber group, which made important contributions on parity-violation in strange particles. Subsequently he became professor at the University of Bari.

In 1968 he was appointed senior scientist at DESY and took an active part in the experimental programme for the DORIS electron-positron storage ring. He first gained experience with an experiment at the Frascati storage ring and then became one of the initiators of the PLUTO experiment. He was instrumental in obtaining the first large superconducting solenoid magnet for this type of work in Europe. Among the results

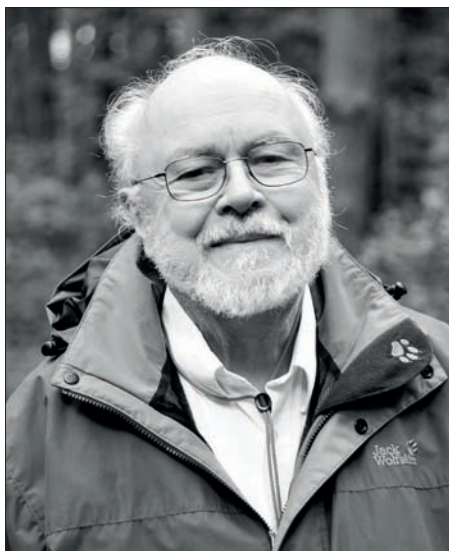

Pedro Waloschek. (Image credit: Nick Wall.)

of the PLUTO experiment, the investigation of the then newly discovered Y resonance is especially noteworthy, leading to an early indication of the existence of the gluon and its spin.

From 1978 Pedro started an additional career as a science writer, communicating the exciting results of high-energy physics to the German-speaking public. For most of the 1980s he was head of the DESY Public Relations group. Apart from articles in newspapers and magazines, he wrote more than 20 books, including *Reise ins Innerste der Materie (Journey into innermost matter)*, the story of DESY's electron-proton collider HERA, 1991), *Der Multimensch* (on scientific collaborations, unravelling the secrets of quarks and leptons) and a book on the life and work of Rolf Wideröe, published in German and English (*CERN Courier* April 2008 p38). He became DESY's official *CERN Courier* correspondent in 1979, and was one of the longest-serving and most productive informants.

Pedro will be sorely missed by his many friends and admirers in many countries for his enthusiasm and engagement in science and science journalism, and for his positive and friendly personality.

● *Petra Folkerts and Erich Lohrmann, DESY.*

Faces & Places

Fang Lizhi 1936–2012

Fang Lizhi (also Li-Zhi), astrophysicist and cosmologist, passed away on 6 April in Tucson, where he had lived for more than 20 years, teaching in the department of physics at the University of Arizona. He introduced relativistic astrophysics and cosmology to China and played an important role in the democracy movement of the 1980s and the development of international relations.

Relativistic astrophysics and cosmology was born in 1967 with observation of the first pulsar, following the discovery of the cosmological background radiation in 1965. It was a by-product of the launch of the space age by John F Kennedy, the development of NASA, and the inspired work of three small groups of highly motivated scientists at Princeton, Cambridge and Moscow. After nine years of collaboration with John A Wheeler in Princeton, one of us (RR) had the good fortune to enter China in 1979 and meet Fang Lizhi and his wife, and scientific collaborator, Li Shu-Xian. Lizhi had already been marked as a dissident at the age of 36, by writing a paper “A cosmological solution in scalar-tensor theory with mass and black body radiation”, which was in stark conflict with the principal dogma purporting an everlasting universe.

A long-lasting friendship developed between Remo and Lizhi. They delivered a joint lecture series in numerous universities of China, many of which bore the scars of the cultural revolution. This resulted in a small red book defining the new field of research, priced at 0.99 yuan, which became as revered among physics students as the other small red book. It is still in print today in China (Taiwan) and it is hoped that in the near future, a new edition will be available in China (Mainland).

In 1983 Lizhi and Remo succeeded in organizing the first international scientific meeting in China: the Third Marcel Grossmann meeting in Shanghai. On this occasion, with help of the president of the China Association of Science and Technology, Zhuo Pei Yuan, they succeeded

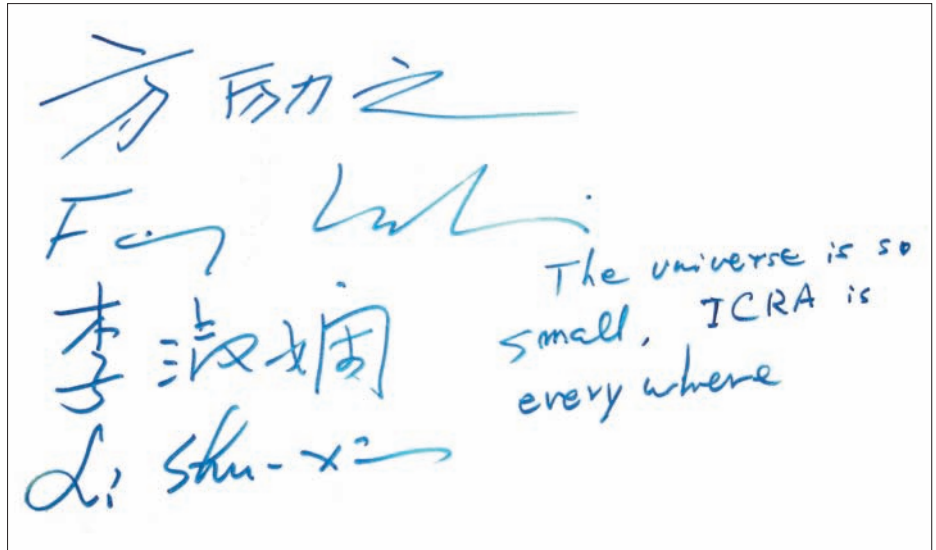

The signatures of Fang Lizhi and Li Shu-Xian on the wall of ICRA, University of Rome, photographed in April 2012. (Image credit: ICRA Net Archive.)

in promulgating a paradigm shift in the Chinese way of life: the motto “Friends from all over the world are welcome” became “Scientists from all over the world are welcome”. This allowed, among other things, the participation of Israeli scientists in this scientific celebration of the ideas of Albert Einstein.

After a tumultuous period in the years 1989–1990, Lizhi and Li Shu-Xian settled in Tucson and continued their scientific work, as well as participation in international academic activities. In 2005 Lizhi and Remo co-founded the International Center for Relativistic Astrophysics (ICRANet), an international organization to “promote international scientific co-operation and undertake research in the field of relativistic astrophysics”. The ICRANet Members are today four states – Armenia, Brazil, Italy and the Vatican – as well as the University of Arizona, the University of Stanford and ICRA, at the University Rome.

Lizhi became the president of the steering committee, while Riccardo Giaconci was, and continues to be, the first president of the Scientific Committee. The activities

promoted by ICRANet include the Galileo Xu Guan Qi (GX) meetings, held yearly in China and in the West alternately, with a maximum of 137 participants each from China and from the West. GX1 was held in Shanghai, GX2 in Nice and GX3 in Beijing. Lizhi saw ICRANet connect China and the West in terms of experience and knowledge about the universe, with exchanges among scientists independently of their creed, political and social status.

A few weeks ago, one of us (JR) walked into Lizhi's office and asked when he was moving back to China to pick up where he had left off. This remark had been prompted by a health issue: Lizhi had been suffering from the Arizona Valley fever (*Coccidioidomycosis*) and a move out of the desert is a possible response to the many complications that can follow. Lizhi thought for a long time, and it seemed that the answer was, “I think, tomorrow”, but it was never spoken.

● Johann Rafelski, Department of Physics, University of Arizona, and Remo Ruffini, ICRANet and University of Rome “Sapienza”.



VACUUM VALVES

www.vatvalve.com

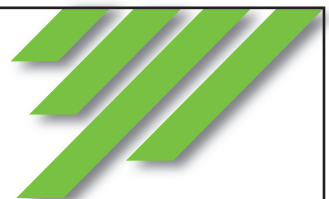

Recruitment

FOR ADVERTISING ENQUIRIES, CONTACT *CERN COURIER* RECRUITMENT/CLASSIFIED, IOP PUBLISHING, TEMPLE CIRCUS, TEMPLE WAY, BRISTOL BS1 6BE, UK.
TEL +44 (0)117 930 1264 FAX +44 (0)117 930 1178 E-MAIL SALES@CERN Courier.COM
PLEASE CONTACT US FOR INFORMATION ABOUT RATES, COLOUR OPTIONS, PUBLICATION DATES AND DEADLINES.



Accelerator Physicist

The Physics Division at Argonne National Laboratory invites applications and nominations for a staff position in accelerator physics with an emphasis in low-energy heavy-ion beam optics in a superconducting RF environment. Applicants in any sub-area will be considered but some advantage will accrue to applicants with experience directly applicable to the operation of the Argonne Tandem-Linac Accelerator System (ATLAS), a DOE-funded National User Facility. This position is within the ATLAS operations group and will include hands-on assistance to operations staff for new and difficult operating conditions as well as staff training and communication of new or improved techniques. The appointment is anticipated to begin as soon as possible.

We are seeking candidates with an outstanding, established record and great promise for future growth in research. We plan to appoint at the rank of Assistant Physicist (PhD plus at least two years postdoctoral experience), which is the Laboratory's equivalent of a tenure-track Assistant Professor position, although a more senior appointment may also be considered in special cases. Candidates must apply through the Argonne web site at www.anl.gov/jobsearch/search.jsp under requisition number 319209 PHY supplying the following:

- Curriculum vitae
- List of publications
- List of people prepared to provide a letter of reference on behalf of the applicant and their addresses
- Brief description (not more than 2 pages) of research interests and goals

For additional information applicants should contact Richard Pardo, Physics Division, Argonne National Laboratory, Lemont, IL 60439. Email: pardo@phy.anl.gov

Applications received by **Monday 6th August 2012**, will receive our fullest consideration. Argonne is one of the pre-eminent multidisciplinary research facilities in the Nation, located about 25 miles southwest of Chicago. It is a U.S. Department of Energy laboratory managed by **UChicago Argonne, LLC**. The **Physics Division** has a staff of about 100, including 36 PhD staff members and 27 postdoctoral scholars. Major research programs include low-energy nuclear physics, nuclear and hadron theory, medium energy nuclear physics, and accelerator technology.

Argonne is an equal opportunity employer and we value diversity in our workforce.

Department of Physics

Joint Lectureship in Accelerator Physics

Salary is in the range £37,012 to £44,166 per annum inclusive of London Allowance

Royal Holloway, University of London (RHUL) and the UK Science and Technology Facilities Council (STFC) intend to make a joint Lecturer appointment in Accelerator Physics.

RHUL is part of the John Adams Institute for Accelerator Science, a joint venture between Oxford University, RHUL, Imperial College London and STFC. The RHUL accelerator physics group is currently involved in projects at the ATF2 at KEK, CTF3 at CERN, PETRA3 at DESY, DIAMOND and the Front End Test Stand at STFC's Rutherford Appleton Laboratory (home of the proton-accelerator-based ISIS spallation neutron source), the ESS at Lund, and the LHC at CERN. Our projects are currently built around expertise in laser-based beam diagnostics, advanced RF systems and design, cavity BPMs, radiation physics, and advanced simulation. The successful candidate would not be restricted to work in these areas but would also be welcome to contribute to them.

We are looking to make a Lectureship appointment to establish a vibrant joint programme of accelerator physics at Royal Holloway and STFC; we particularly welcome applicants in the area of proton machines. You should have considerable postdoctoral research experience and be developing an international reputation in the field. This is an excellent opportunity to be part of a growing joint programme and would suit someone who aspires to a leading role in a major national laboratory, while establishing a strong academic profile in one of the larger colleges of the University of London.

For an informal discussion about the post please contact Professor Grahame Blair at G.Blair@rhul.ac.uk

This post is based in Egham, Surrey.

For further details of this post, please view and apply online at <https://rhul.engageats.co.uk> The Recruitment Team can be contacted by email at: recruitment@rhul.ac.uk or via telephone on: 01784 414241.

Please quote the reference: X0512/4583.

Closing date: Midnight, 2 July 2012.

Interviews likely to be held: 24 July 2012.

The College is committed to equality and diversity, and encourages applications from all sections of the community.



EUROPEAN
SPALLATION
SOURCE

European Spallation Source AB is preparing to construct a world-leading European materials research centre in Lund, Sweden. ESS is partnered by a large number of European countries.

Be part of the future!

We are looking for a highly qualified:

ACCELERATOR SCIENTIST
ACCELERATOR SYSTEM ENGINEER

See all our positions at: www.ess.se/careers

Visit **brightrecruits.com**
for your next career move

We're ready with advanced technology products and services for the oil and gas industry. All we need is you.

Please visit our website at jobs.gecareers.com and apply to Req #1401561.

GE Oil & Gas (www.ge.com/oilandgas) is a world leader in advanced technology equipment and services for all segments of the oil and gas industry.

Nuclear Physicist - Farnborough, Hampshire

Join the GE Downhole Technology leading-edge R&D team designing harsh environment products and processing algorithms for use in oil and gas wells. You will be actively involved in developing instruments that exploit the nuclear properties of matter to provide oil companies with important data in both new and established wells.



GE imagination at work

An equal opportunity employer.



Visit
brightrecruits.com

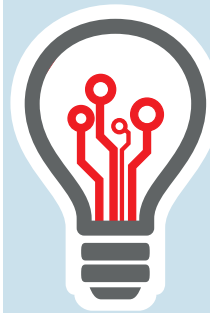

Want to get noticed?
Try our video package

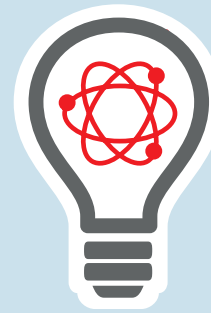

Exploit our high-impact position options

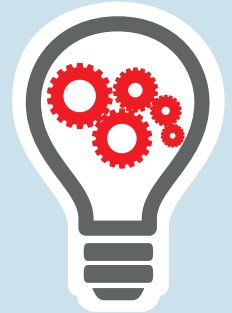

Stay in control
with our improved recruiters' area

The jobs site
for physics and
engineering



Nominations for Editor in Chief of EPL

Nominations are now open for the Editor in Chief of EPL, a leading, global letters journal owned and published by a consortium of 17 physical societies in Europe. The Editor in Chief (EiC) needs to be a recognized authority and leading researcher in a field of physics, and have a broad knowledge and interest in physics and its frontiers. A proven ability to interact with senior scientists is required. The EiC will need to demonstrate strong commitment and leadership to further develop EPL as a top-ranking journal. Experience with the editorial process for a physics journal is also desirable. The EiC is central to enhancing EPL's position as an outstanding global physics letters journal. The term of office of EPL Editor in Chief is three and a half years beginning in March 2013. A job description is available at <https://www.epletters.net>.

Nominations may be made by the individual concerned, or by third parties not later than 15 July 2012. Nominations must include a CV, publication list and a brief covering letter by the individual concerned explaining his/her interest and qualifications for the post. Candidates should also discuss his/her ideas for the growth and development of EPL. Nominations should be sent to the chair of the selection committee care of the EPL Editorial Office (editorial.office@epletters.net).



WE DO BOTH HEMISPHERES

International Recruitment: up to 50 new posts

Durham University research is amongst the best in the world, making a real difference to the issues that matter to our global society. Internationally, we're ranked 26th (THE 2012) for the impact of our research.

Our Social Sciences and Humanities are both ranked in the Top 50, and our research in Space Science and Cosmology has been ranked 1st in Europe and 4th in the world (Reuters).

We have embarked on a major academic investment and development strategy to build on our position as a leading but distinctive university for global research and education. With this in mind, we've identified twelve strategic areas for academic recruitment across the Arts and Humanities, Sciences and Social Sciences.

As a university with a focus on research and research-led education, we believe in excellence and are looking for the world's most creative minds to join us.

- Professor/Reader in Computational Mathematical-Biology
- Professor/Reader in Computational Field Theory
- Professor/Reader in Complex Fluids (Experimental)
- Professor/Reader/Senior Lecturer/Lecturer in Theoretical Soft and Biological Matter
- Professor/Reader in Protein Dynamics and Biomolecular Interactions
- Professor/Reader in Surface and Interface Chemistry

For more information, visit www.joindurham.com

Bookshelf

CERN's accelerators, experiments and international integration 1959–2009. *The European Physical Journal H* 36 (4).

By *Herwig Schopper et al. (ed.)*

Springer

In 2009, CERN's Proton Synchrotron (PS) reached its half century, having successfully accelerated protons to the design energy for the first time on 24 November 1959. Still in operation more than 50 years later, it is not only a key part of the injection chain to the LHC but also continues to supply a variety of beams to other facilities, from the Antiproton Decelerator to the CERN Neutrinos to Gran Sasso project. During its operation, the PS witnessed big changes at CERN; at the same time, particle physics itself advanced almost beyond recognition, from the days before quarks to the current reign of the Standard Model.

At the close of the anniversary year, CERN held a symposium in honour of the accelerator developments at CERN and the concurrent rise of the Standard Model: "From the PS to the LHC: 50 years of Nobel Memories in High-Energy Physics" (*CERN Courier* January/February 2010 p24.) Fittingly, at the end of 2009, the LHC – the machine that everyone expects to take the first steps beyond the Standard Model – was just beginning to come into its stride after the first collisions in November.

Key players who had been close to all of these developments, including 13 Nobel laureates, came together for the symposium. Now, several of the talks have been written up and published in the latest edition of *The European Physical Journal H* – the journal launched in 2010 as a common forum for physicists, historians and philosophers of science (*CERN Courier* November 2010 p48). The edition also includes three additional articles that were invited to provide a more complete picture, by covering CERN's Intersecting Storage Rings, the history of stochastic cooling and searches for the Higgs boson at the Large Electron-Positron (LEP) collider – which started up in 1989 and hence celebrated its 30th anniversary at the symposium.

Dip into the pages and you will find many gems: among the Nobel laureates, Jerome Friedman describes the work at SLAC that revealed the reality of quarks, which were unheard of in 1959; Jim Cronin revisits the early 1960s when he and his colleagues discovered CP violation; Jack Steinberger looks back at early experiences at CERN; Carlo Rubbia presents the story of the discovery of W and Z bosons at

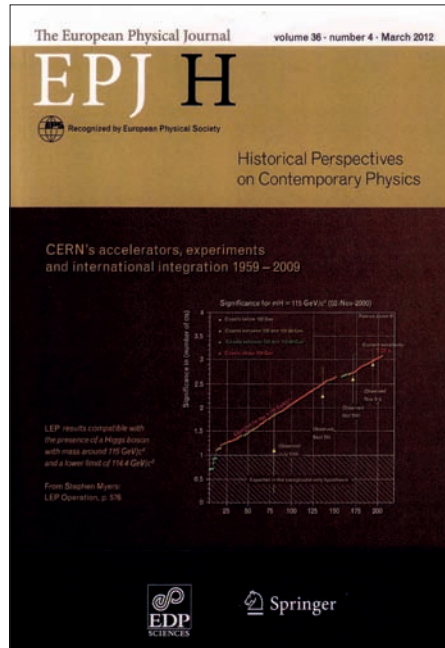

CERN; and Burt Richter recalls early ideas on LEP, from his days on sabbatical at CERN. On the accelerator side, the articles detail developments with the PS, as well as the highlights (and lowlights) of the construction and running of LEP. The invited article on stochastic cooling includes the work of Simon van der Meer, who shared the Nobel prize with Carlo Rubbia in 1984. Sadly, he was too ill to attend the symposium and passed away in March 2011 (*CERN Courier* June 2011 p24).

All of the articles provide an interesting view of remarkable events through the reminiscences of people who were not simply "there", but who played a big part in making them happen. They are a fascinating reminder of what particle physics was like in the past and well worth a read. They also reflect the different styles of the various individuals, but not so much, perhaps, as did the original presentations at the symposium. To get the full flavour, and to see all the participants, take a look at the recordings at <http://indico.cern.ch/conferenceDisplay.py?confId=70765>. There you will find still more gems.

● *Christine Sutton, CERN.*

Books received

The Fundamentals of Imaging: From Particles to Galaxies

By *Michael Mark Woolfson*

Imperial College Press

Hardback: £65 \$98

Paperback: £32 \$48

E-book: £87 \$127

The range of imaging tools, both in the type of wave phenomena used and in the devices that utilize them, is vast. This book illustrates this range, with wave phenomena that cover the entire electromagnetic spectrum, as well as ultrasound, and devices that vary from those that simply detect the presence of objects to those that produce images in exquisite detail. The aim also is to give an understanding of the principles behind the imaging process and a general account of how those principles are utilized, without delving into the technical details of the construction of specific devices.

A Modern Introduction to Particle Physics (3rd edition)

By *Fayyazuddin and Riazuddin*

World Scientific

Hardback: £54 \$82

The Pakistani brothers, who were both students of Abdus Salam, wrote the first edition of their book in 1992, based on lectures given in various places. Aimed at senior undergraduates or graduate students, it provides a comprehensive account of particle physics. Having first been updated in 2000, this latest edition contains many revised chapters, in particular those that cover subjects such as heavy flavours, neutrinos physics, electroweak unification, supersymmetry and string theory. Another addition is a substantial number of new problems. This self-contained book covers basic concepts and recent developments, as well as overlaps between astrophysics, cosmology and particle physics.

Principles of Radiation Interaction in Matter and Detection (3rd edition)

By *Claude Leroy and Pier-Giorgio Rancoita*

World Scientific

Hardback: £153 \$232

E-book: \$302

Like its predecessors, this third edition addresses the fundamental principles of the interaction between radiation and matter and the principles of particle detection and detectors in a range of fields, from low to high energy, and in space physics and the medical environment. It provides abundant information about the processes of electromagnetic and hadronic energy deposition in matter, detecting systems, and performance and optimization of detectors, with additional information in the third edition. A part of the book is also directed towards courses in medical physics.

First Choice in Synchrotron Instrumentation

Insertion Devices — **Beamlines** — Experimental Stations



Double Crystal Monochromator with Cryo Cooler

- Complete Beamlines
- Monochromators
- Cryo Coolers
- Mirror Systems
- Beamline Components
- Design Studies

Bruker ASC is a leading developer, manufacturer and vendor of high performance synchrotron and X-ray research instrumentation, specialized superconducting magnets, innovative electrotechnical energy devices and industrial process equipment. Based on the exceptional experience and know-how of our staff and on our extensive operational resources we offer design studies, components and turn-key systems as well as one-off and serial production.

For more information please contact synchrotron@bruker.com or visit www.bruker.com/synchrotron

Visit us at the SRI
conference & exhibition,
Lyon, France,
09. – 13.07.2012

think forward

A former ACCEL Instruments Business

TOUCH THE DIFFERENCE

Products ▼

Support ▼

Services ▼

- Front End ▶
- Power Supply ▶
- Powered Crates ▶
- Accessories ▶
- Firmware/Software ▶

NEW Power Supply Systems for Detectors

LOW price, HIGH flexibility

- The SY4527 is a 19" wide / 8U high mainframe and can house up to 16 boards and provides a power up to 4.2 kW
- The SY5527 compact version is 19" wide / 4U high mainframe and can house up to 6 boards and provides a power up to 1.8 kW



A1536 NEW entry in the FAMILY

32 Channel 3 kV/1 mA
Completely independent Channels

- Channels with common floating return
- All parameters such as Voltage, Current, Trip, Ramp-up, Ramp-down, Status alarm, etc... can be independently controlled channel by channel
- Available with either positive or negative polarity
- 200 nA current Set/Monitor resolution
- 200 mV Voltage Set/Monitor resolution

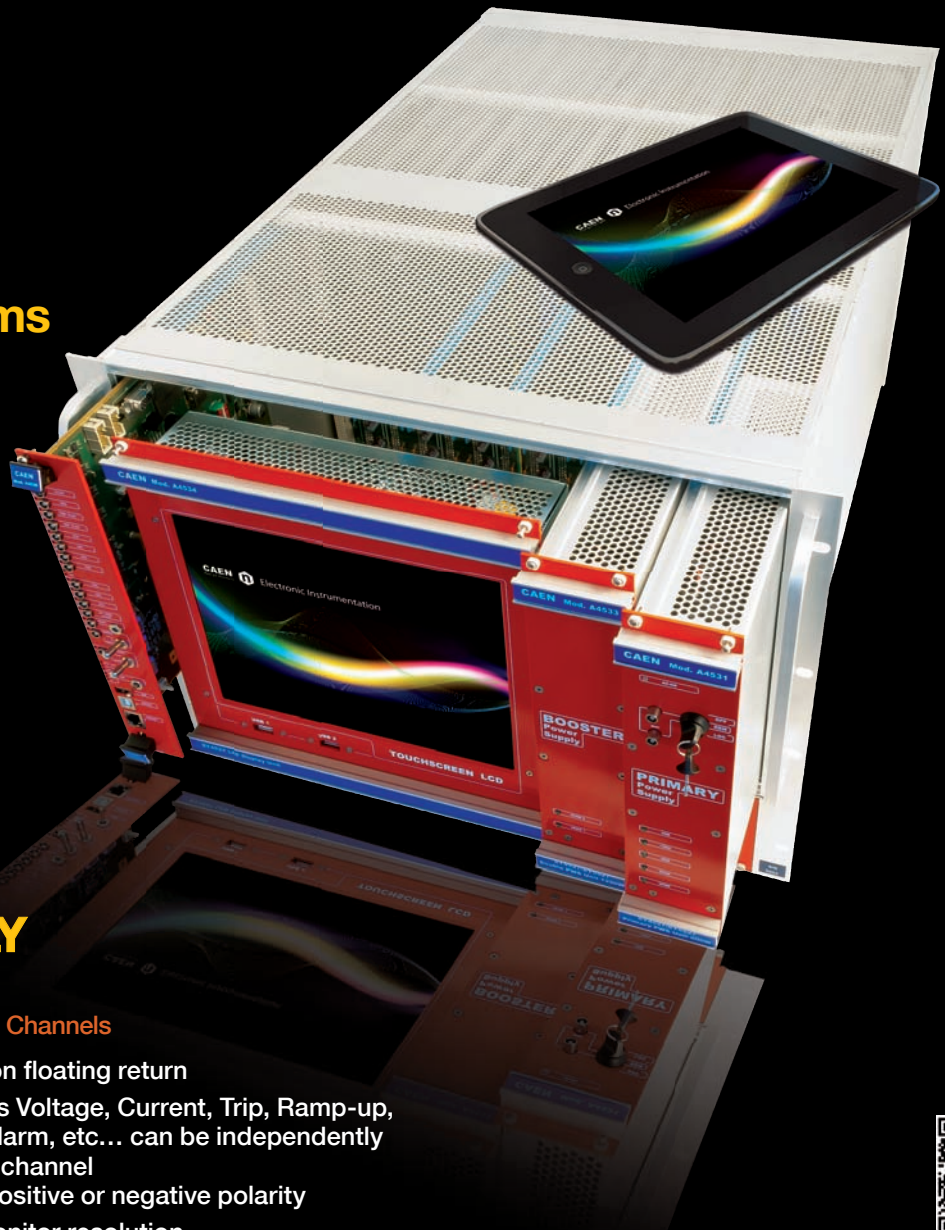

Modular



Touch



Wi-fi



Backward Compatible



 Share-it!

www.caen.it

Artwork: A tribute to CERN COURIER for 10 years of Advertising Campaigns

Embedded Touchscreen Display

10.4" / 5.7"
Colour Touchscreen



AC/DC Power Units

Three different PSU:

- Primary - 600W
- Booster - 600W
- Booster - 1200W



CPU MODULES

Three different versions:

- Basic
- Advanced
- Full

