



# The Associative Memory system for the FTK processor at ATLAS

Saverio Citraro – University of Pisa & INFN

## Introduction

- Fast TracKer (FTK): New online silicon detector tracker for Atlas upgrade based on Associative Memory technique
- FTK working principles
- FTK architecture, with a detailed description of the Associative Memory system
- Test of the prototypes
  - High speed links
  - Pattern Matching in the AM chip
  - Crate cooling

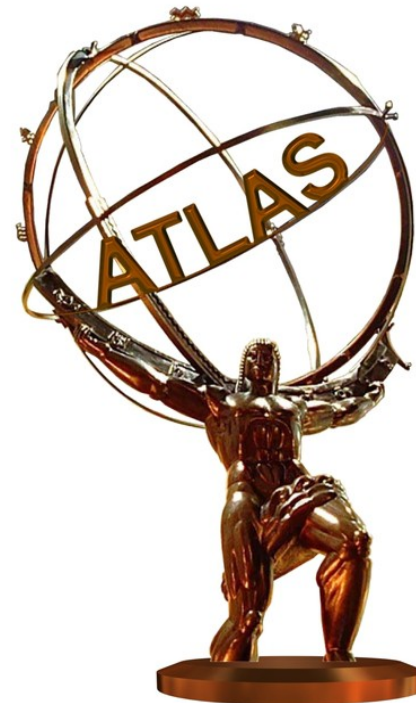

# An online silicon detector tracker for the ATLAS upgrade

- FTK reconstructs charged particles trajectories in the silicon detectors (Pixel & SCT) at “1.5” trigger level.
- Extremely difficult task
  - 25 ns inter-bunch time
  - ~70 overlapping events (pile-up) at Phase I highest luminosity.

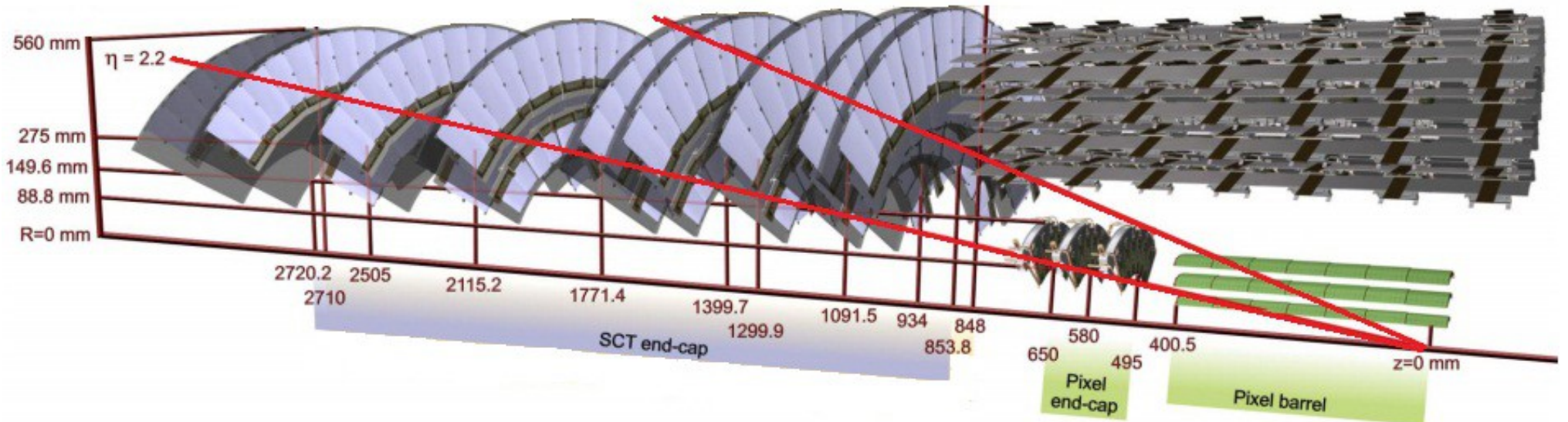
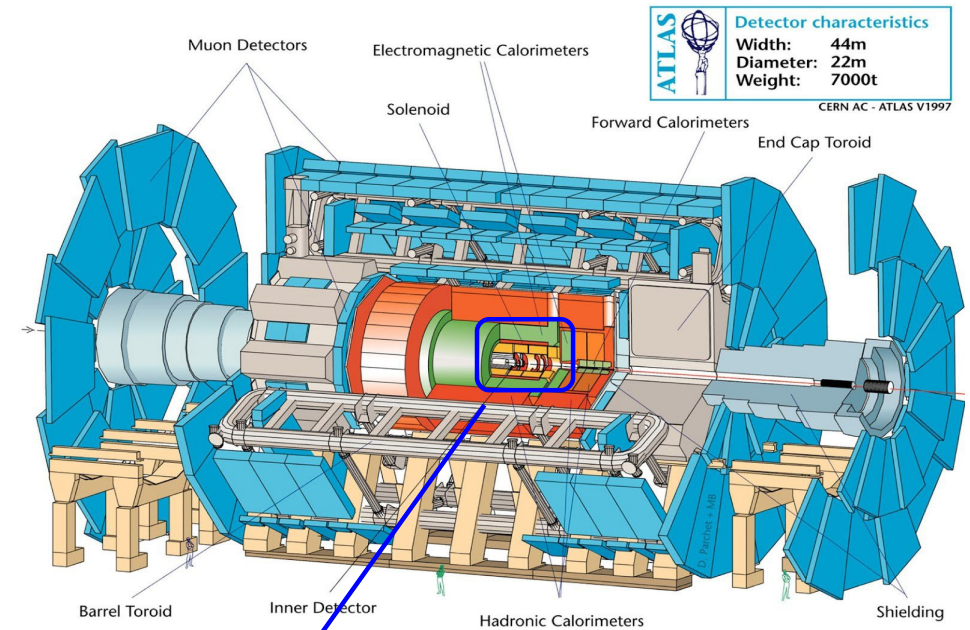

# An online silicon detector tracker for the ATLAS upgrade

- FTK reconstructs charged particles trajectories in the silicon detectors (Pixel & SCT) at “1.5” trigger level.
- Extremely difficult task
  - 25 ns inter-bunch time
  - ~70 overlapping events (pile-up) at Phase I highest luminosity.

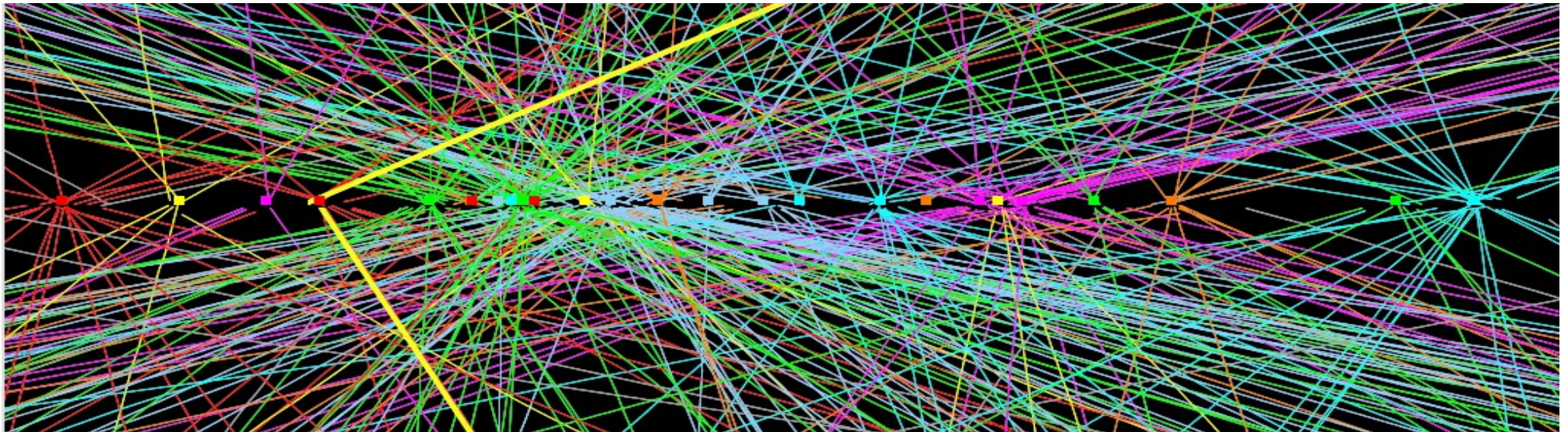
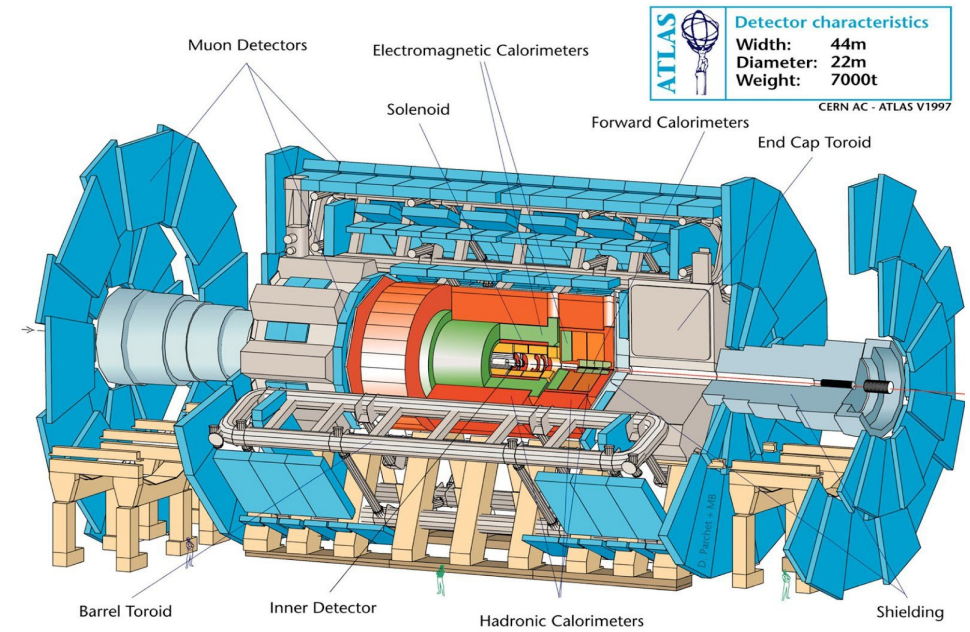

# “1.5” Level Trigger processor

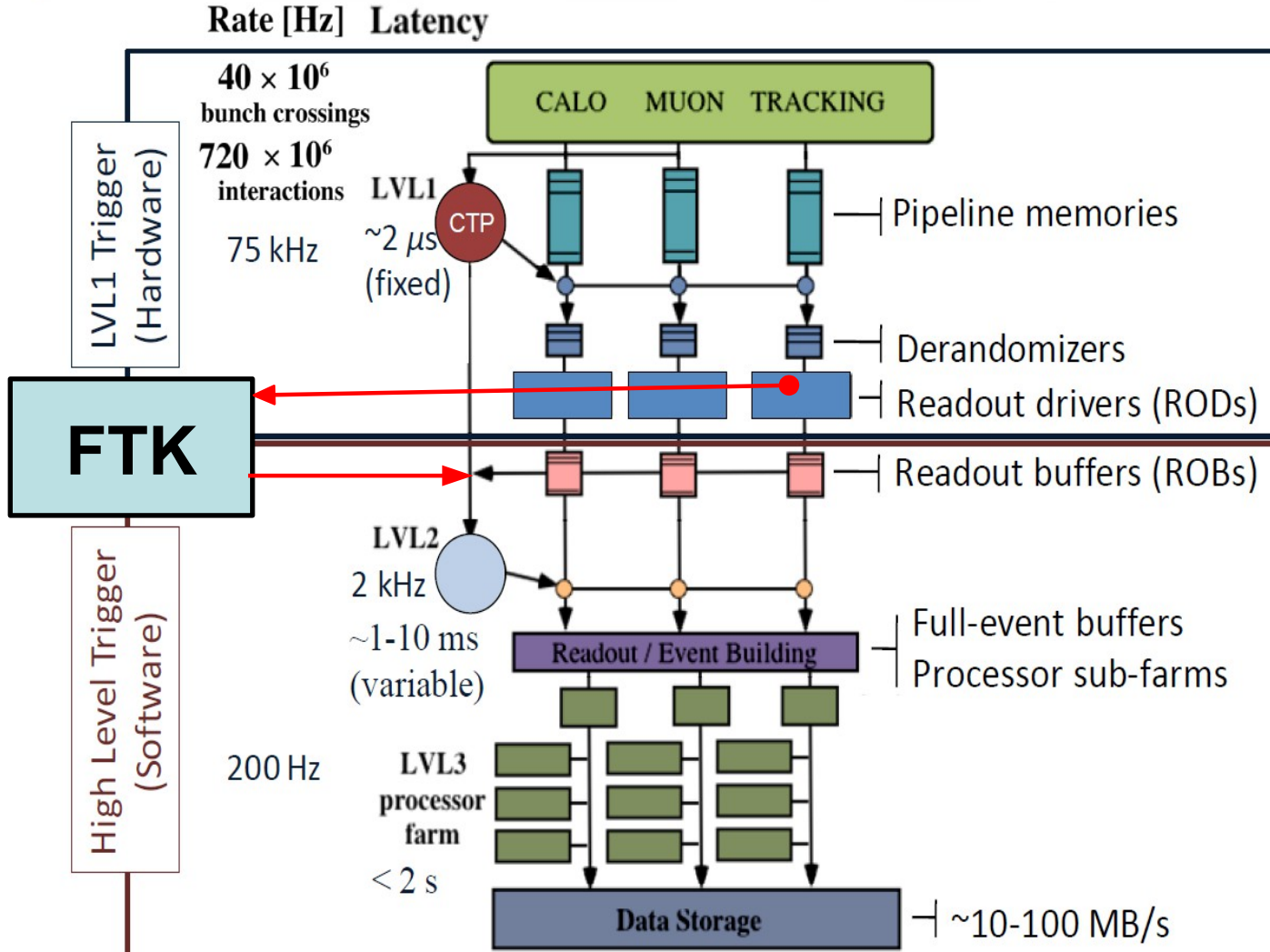

- Silicon data currently used only locally (ROI) and late in Level 2.
- FTK reconstructs all tracks with  $PT > 1$  GeV/c in time for Level 2.
- Track parameters are computed with full detector resolution.

# Where FTK will be inserted in the ATLAS Trigger

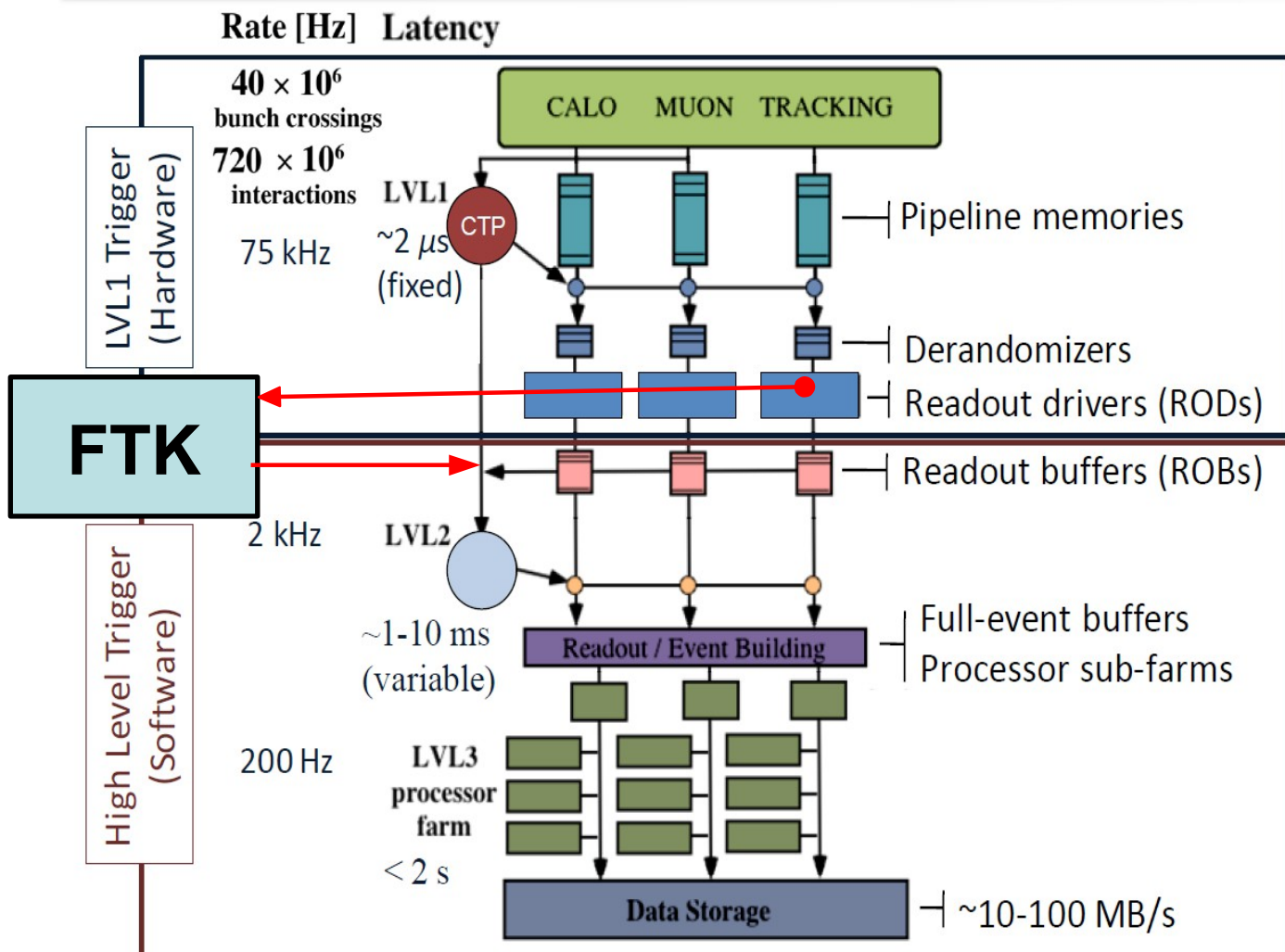

- Silicon data currently used only locally (ROI) and late in Level 2.
- FTK reconstructs all tracks with  $PT > 1 \text{ GeV}/c$  in time for Level 2.
- Track parameters are computed with full detector resolution.

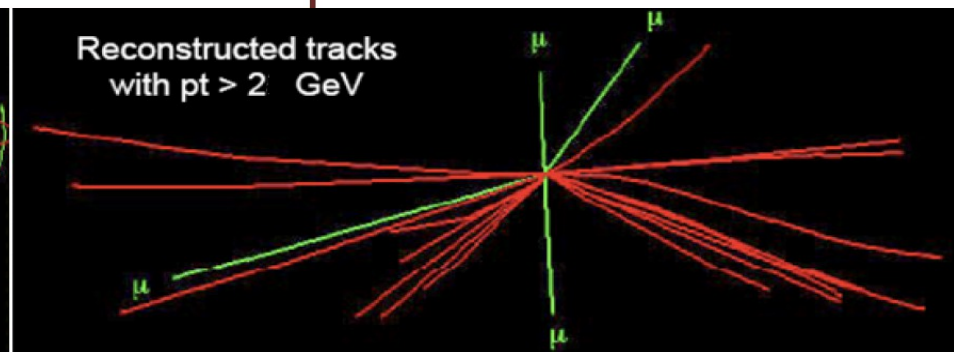
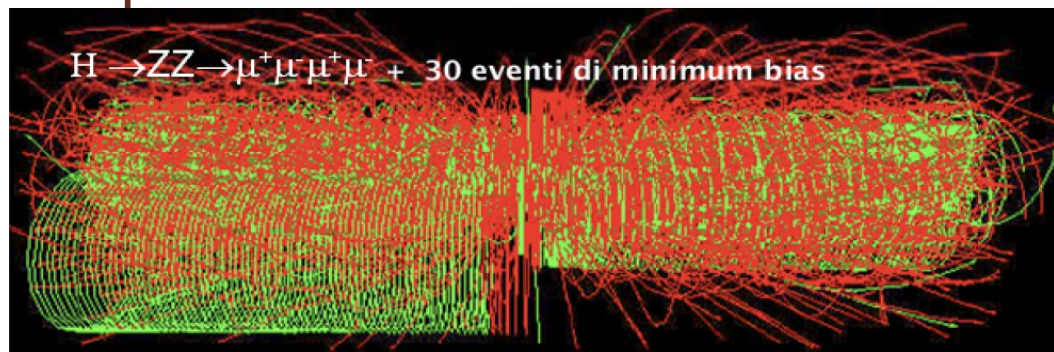

# Pattern matching & track fitting

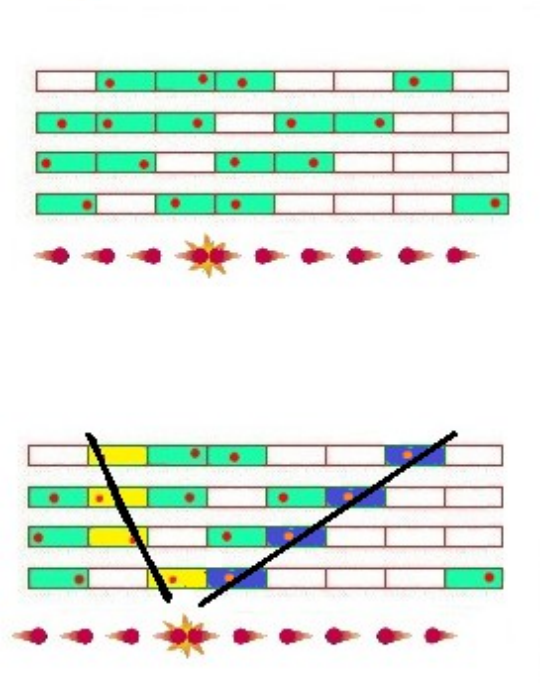

- Pattern Bank: All the possible patterns (low resolution real track candidates) are precalculated and stored in the Pattern Bank.

# Pattern matching

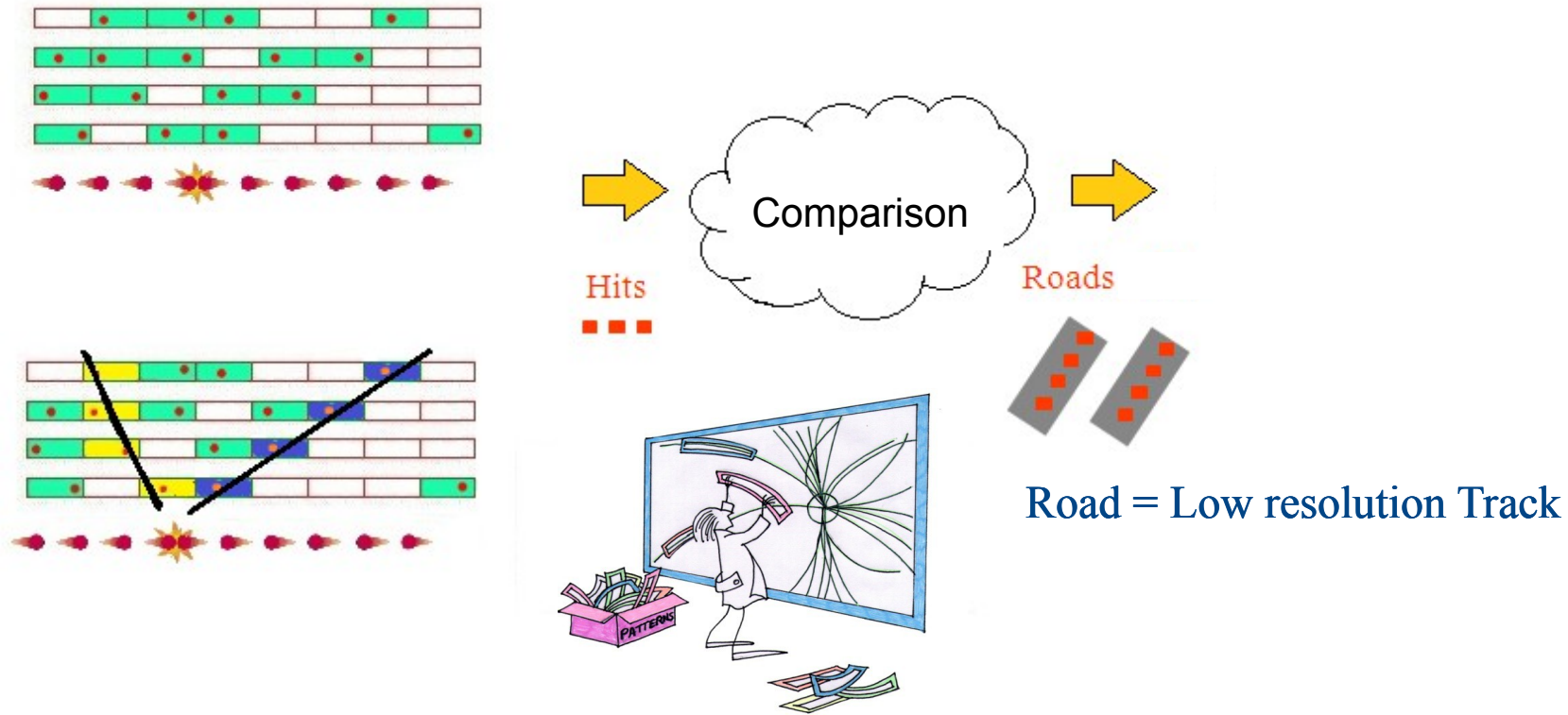

- Pattern Bank: All the possible patterns (low resolution real track candidates) are precalculated and stored in the Pattern Bank.
- Pattern matching: All the hits in each event are compared with all the patterns in the Bank and track candidates (ROADs) are found.



# Pattern matching

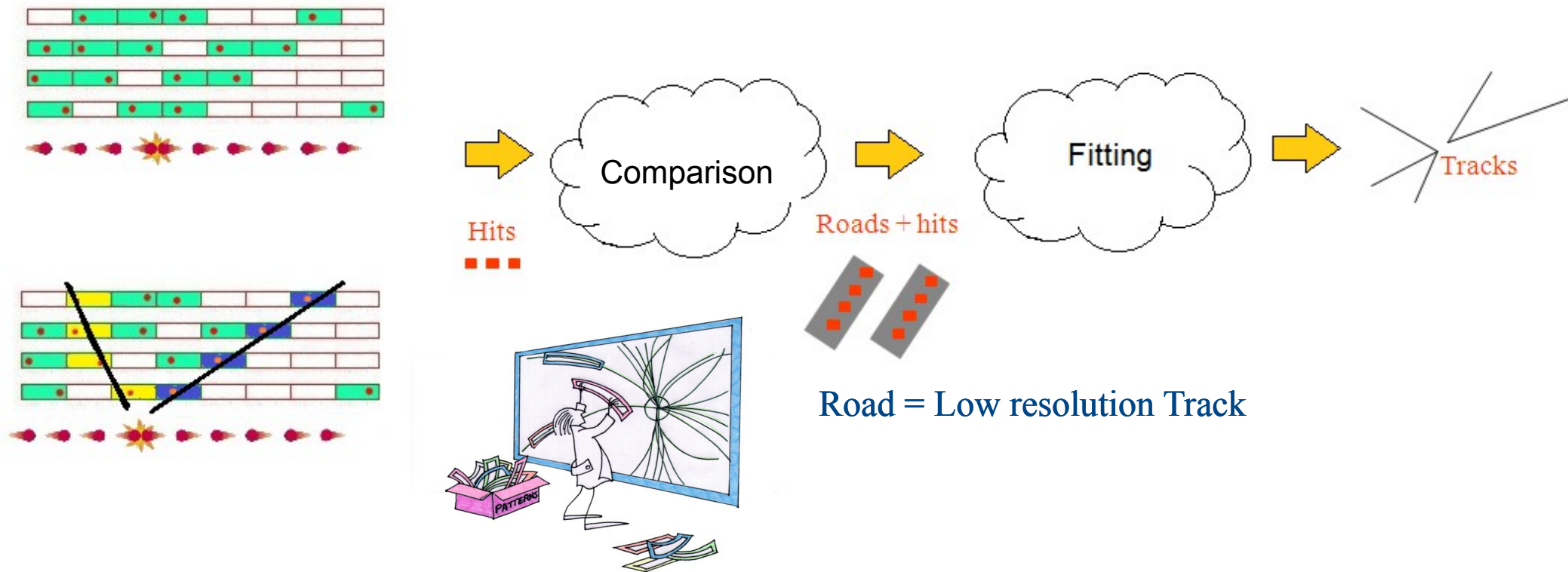

- **Pattern Bank:** All the possible patterns (low resolution real track candidates) are precalculated and stored in the Pattern Bank.
- **Pattern matching:** All the hits in each event are compared with all the patterns in the Bank and track candidates (ROADs) are found.
- **Track Fitting:** Fits of the full resolution silicon HITs contained in each ROAD determine particle tracks parameters.

# Associative Memory

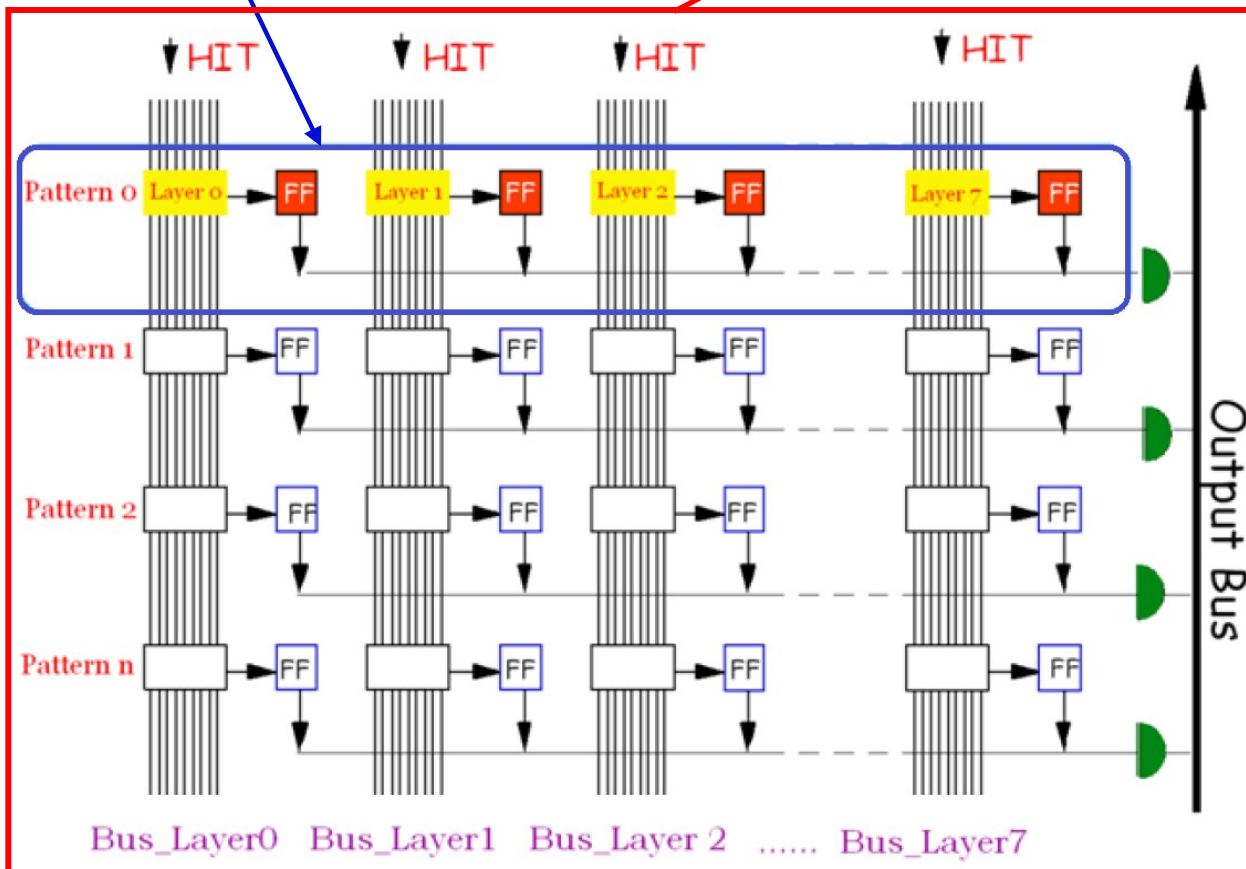
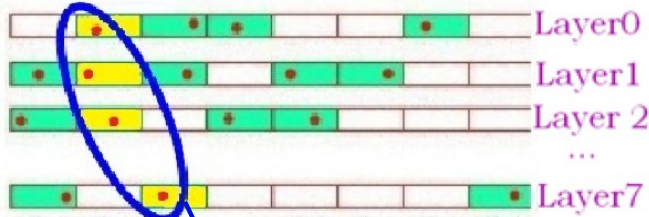

## AMchip

- Custom Associative Memory
- Base element of Pattern Bank
- 1 Pattern stored in 1 row
- Data from 8 silicon layers flow separately on 8 parallel buses (vertical lines)
- Programmable matching threshold
- Matched pattern's addresses are read-out

# FTK architecture

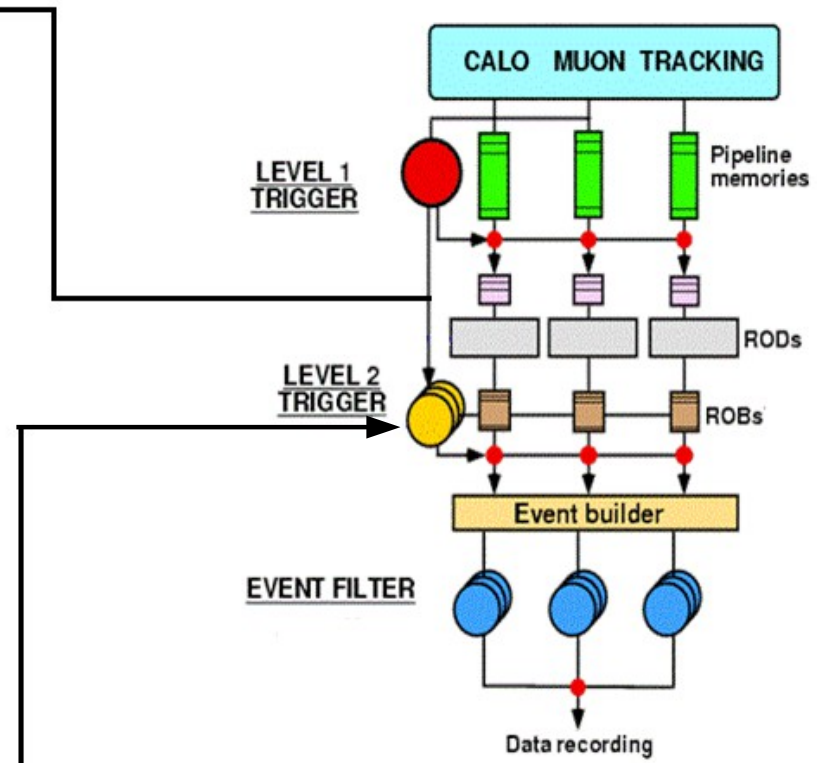
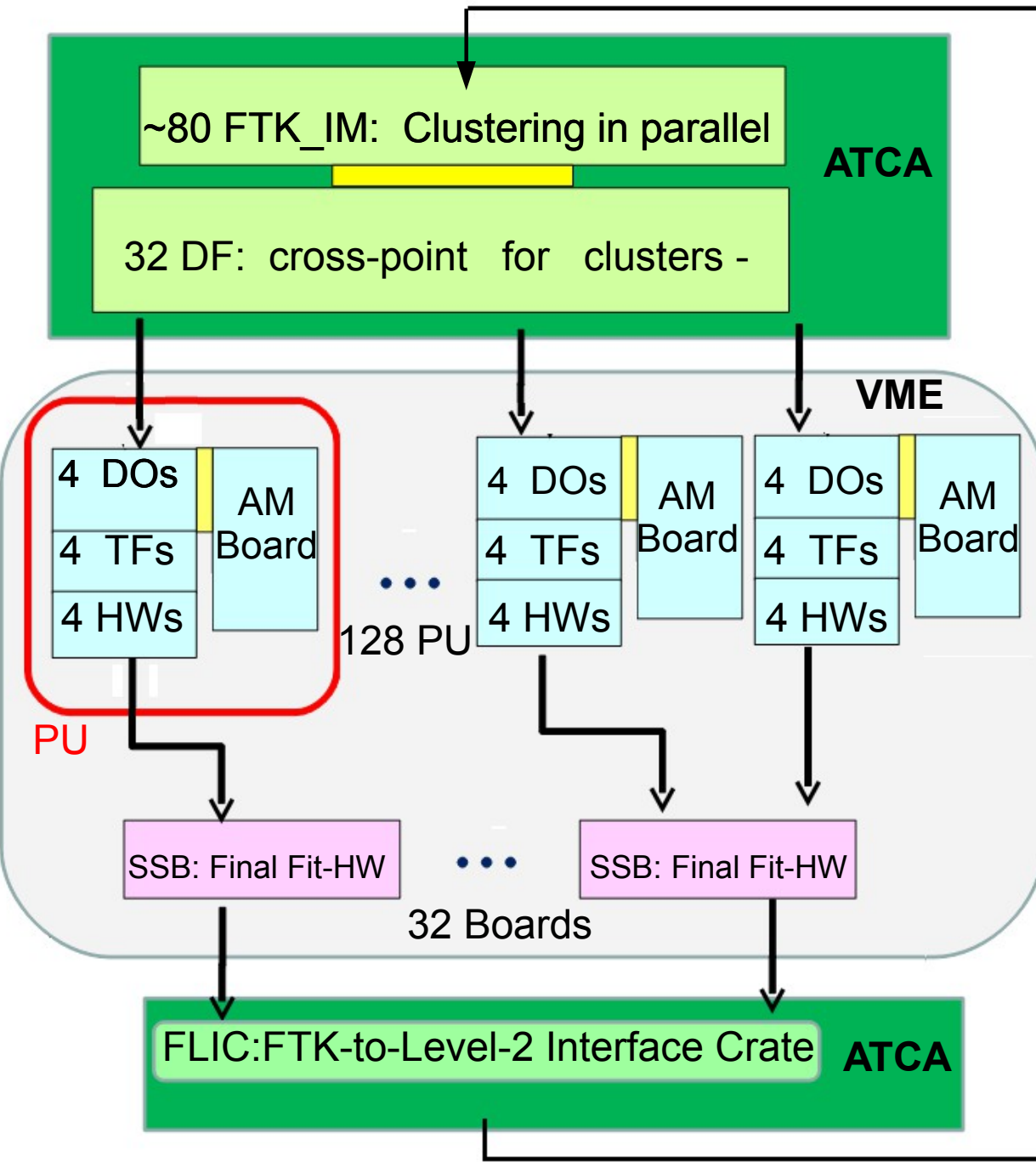

- FTK processor: 8 VME Crates  
5 ATCA Crates
- Processing Unit: track reconstruction core
- 128 Processing Unit:  
~1500 FPGAs  
~8200 AMChips

# Splitting the silicon detector in 64 $\eta$ - $\Phi$ towers

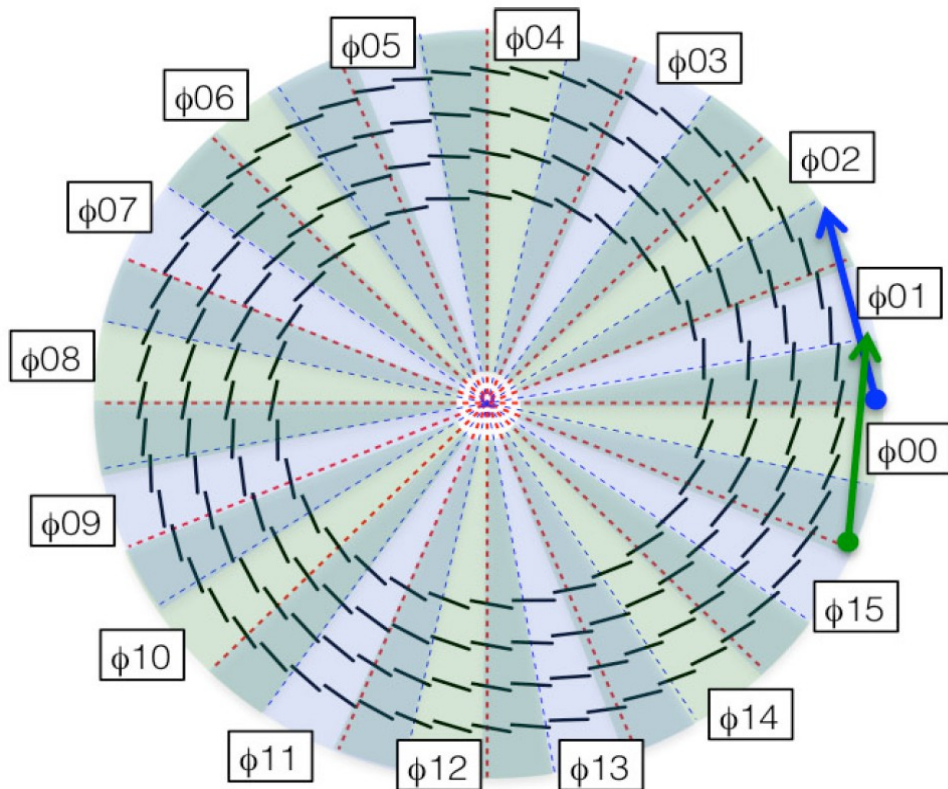
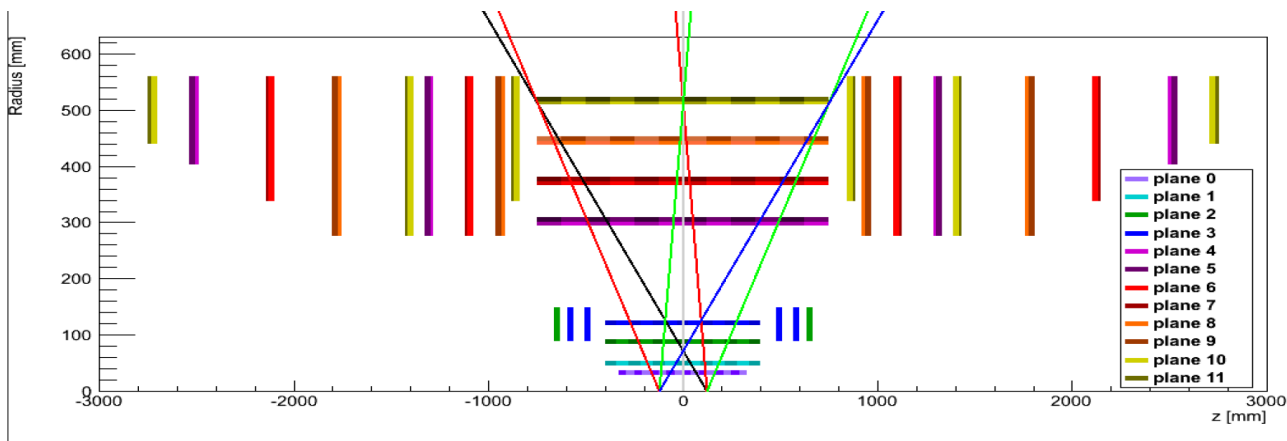

- FTK is organized in 64  $\eta$ - $\Phi$  towers.
- 4  $\eta$  sectors times 16  $\Phi$  sectors.
- The blue and green arrows is an example of overlap coverage.

# FTK Processor Unit

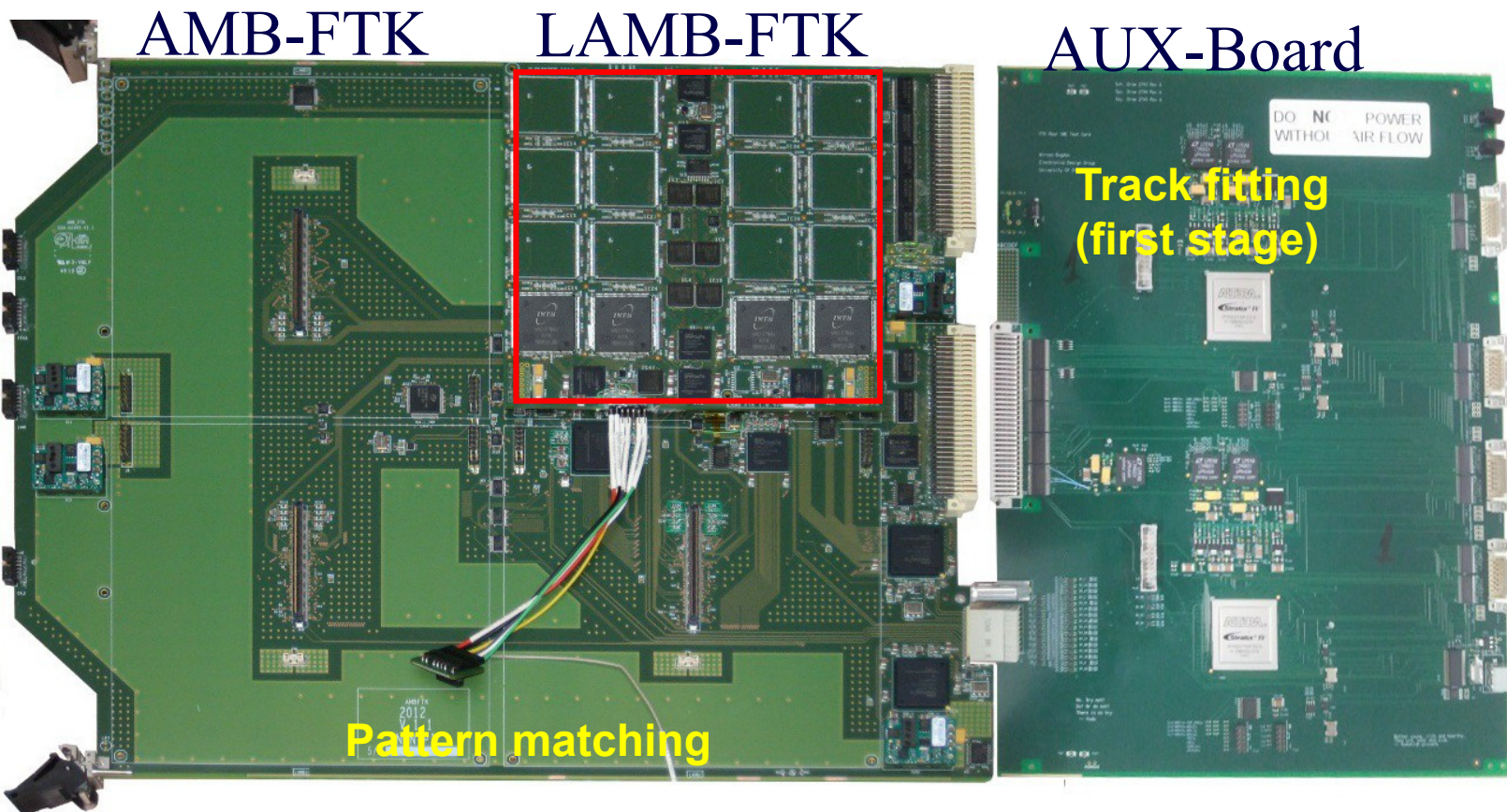

- Processing Unit: 9U VME board (AMB-FTK) + large Rear card (AUX Card) + 4 little mezzanines (LAMB-FTK).
- Silicon HITs relative to events accepted by Level 1 are distributed to all Amchips, this is done in parallel for the 64 tower (1 tower =128 AMChips).
- 1 HIT is compared with ~ 8million of Precalculated pattern.

# FTK Processor Unit

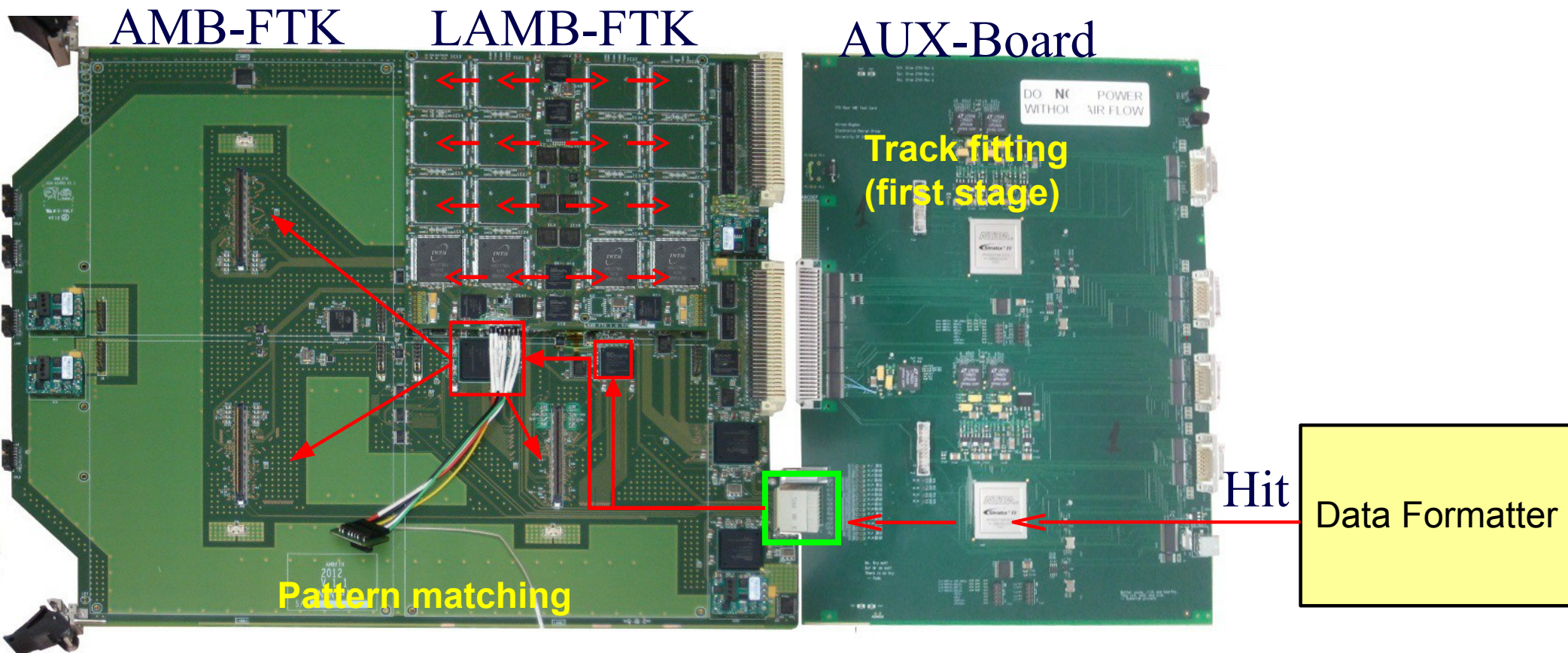

- Data from Data Formatter are distributed by 12 2Gb/s serial links from Data Formatter to the Input FPGAs on the AMBoard.
- Through 4 LAMB connectors to all AMchips.

# FTK Processor Unit

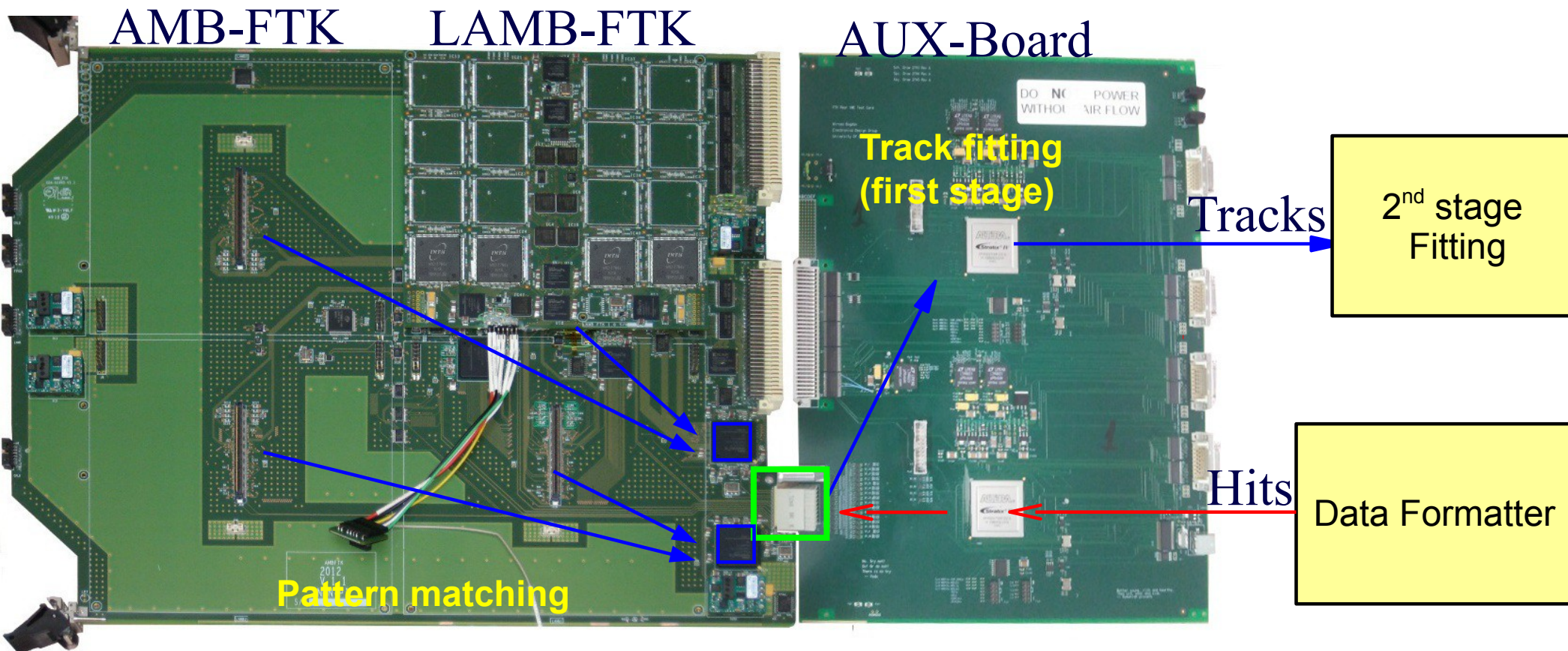

Matched ROADS:

- Collected on the AMB-FTK by 2 Output FPGAs (Blue squares).
- Transmitted to the AUX Board through 16 high-speed links (2Gib/s).

## Prototype Tests

- Test Input Links & FPGAs to correctly send HITs to AM chips.
- Test Output Links & FPGAs to correctly collect the ROADS.
- Test the pattern matching.

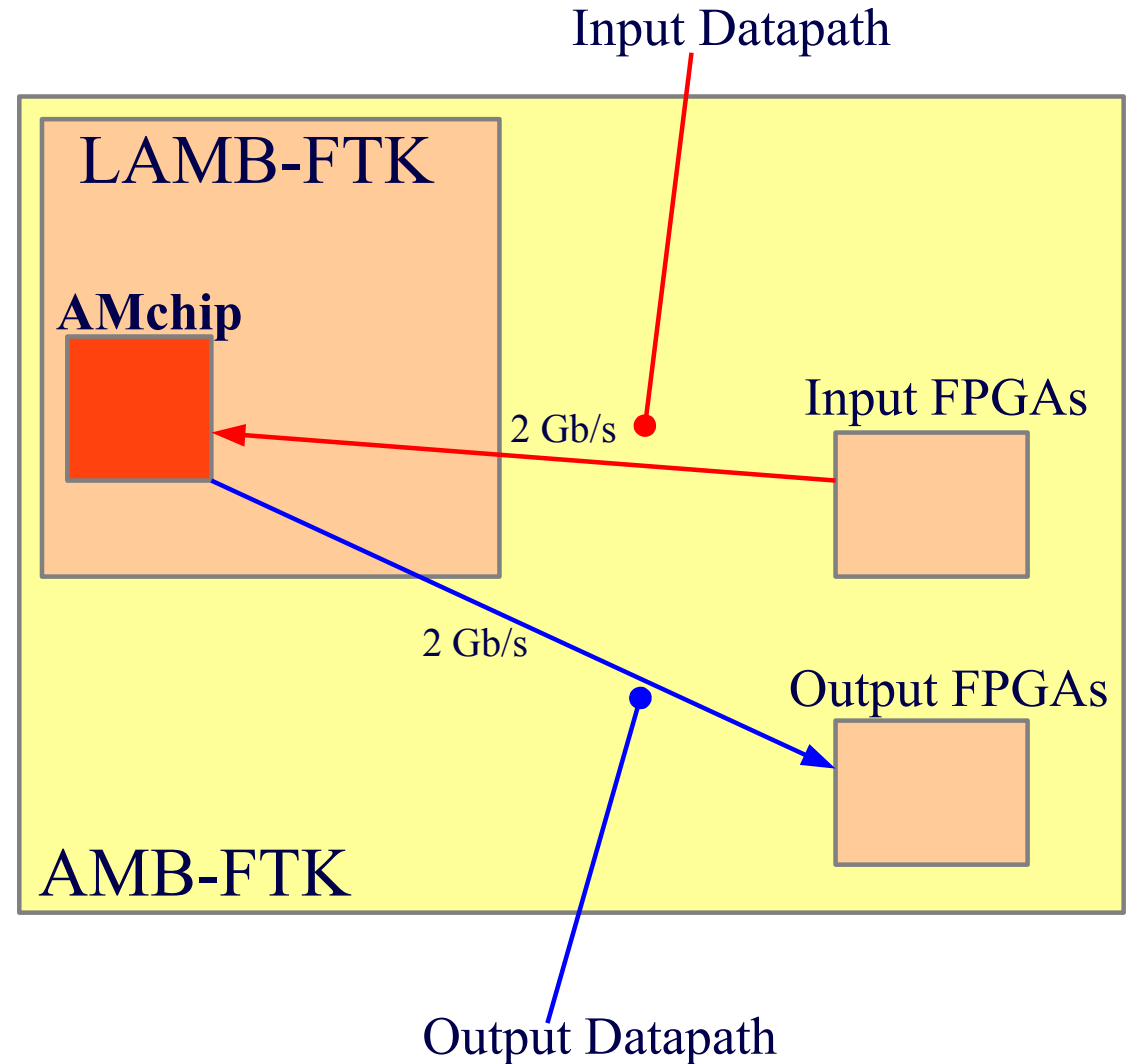



# Test direct links: Hit input and Road Output

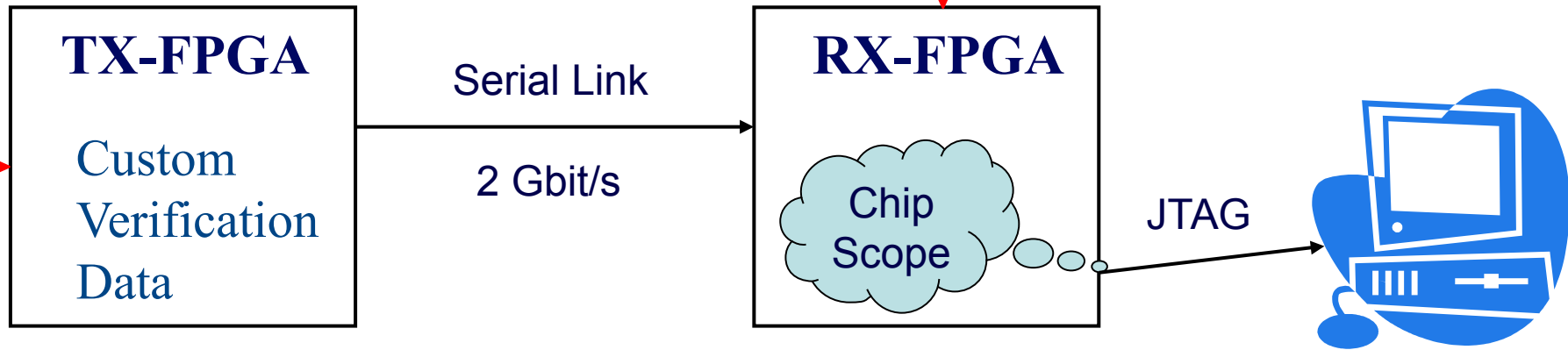
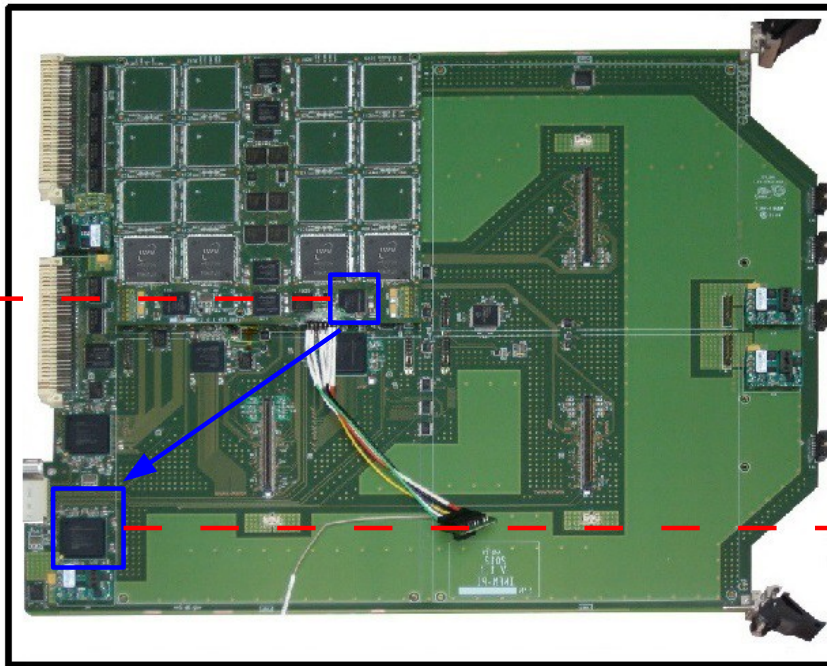

- Sent a known pattern of data from TX and check it in RX with Logical Analyzer.

## Test pattern matching: Store Pattern Bank

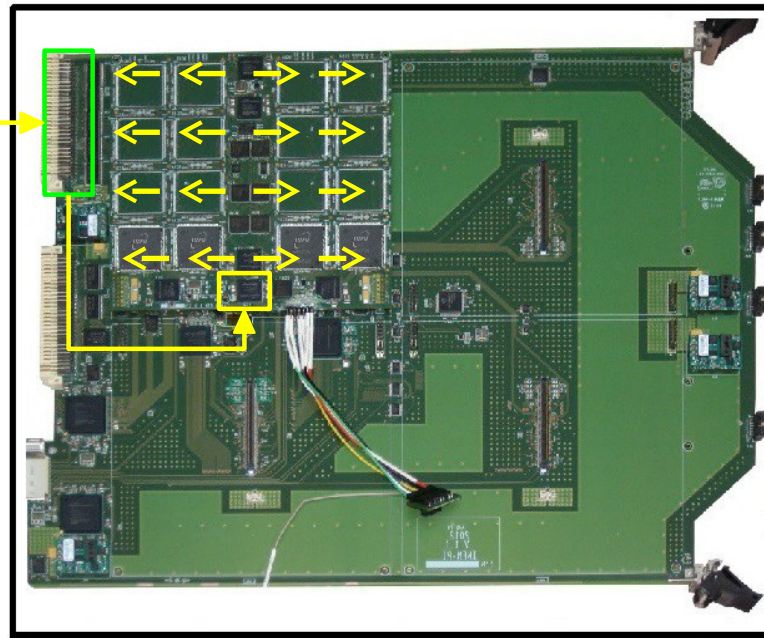
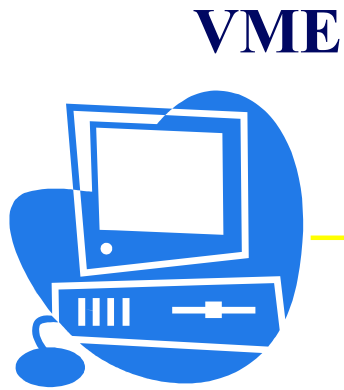

- Step 1: Store precalculated Patterns into Associative memory chips:
  - Through VME the data are stored in the AM by FPGA (yellow arrows)

## Test pattern matching: Send INPUT

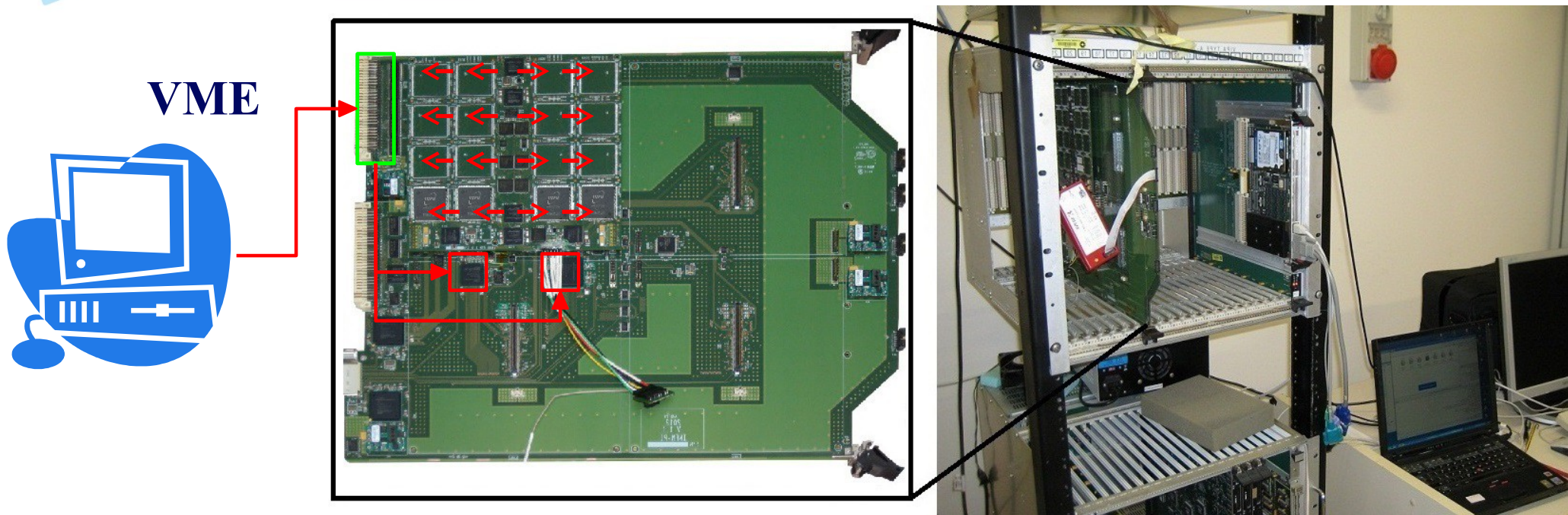

- Step 1: Store precalculated Patterns into Associative memory chips:
  - Through VME the data are stored in the AM by FPGA (yellow arrows)
- Step 2: Simulate silicon HITS Input:
  - Silicon HITS Input are loaded into the inputs FGAs memory (red square) through VME.

## Test pattern matching: Check OUTPUT

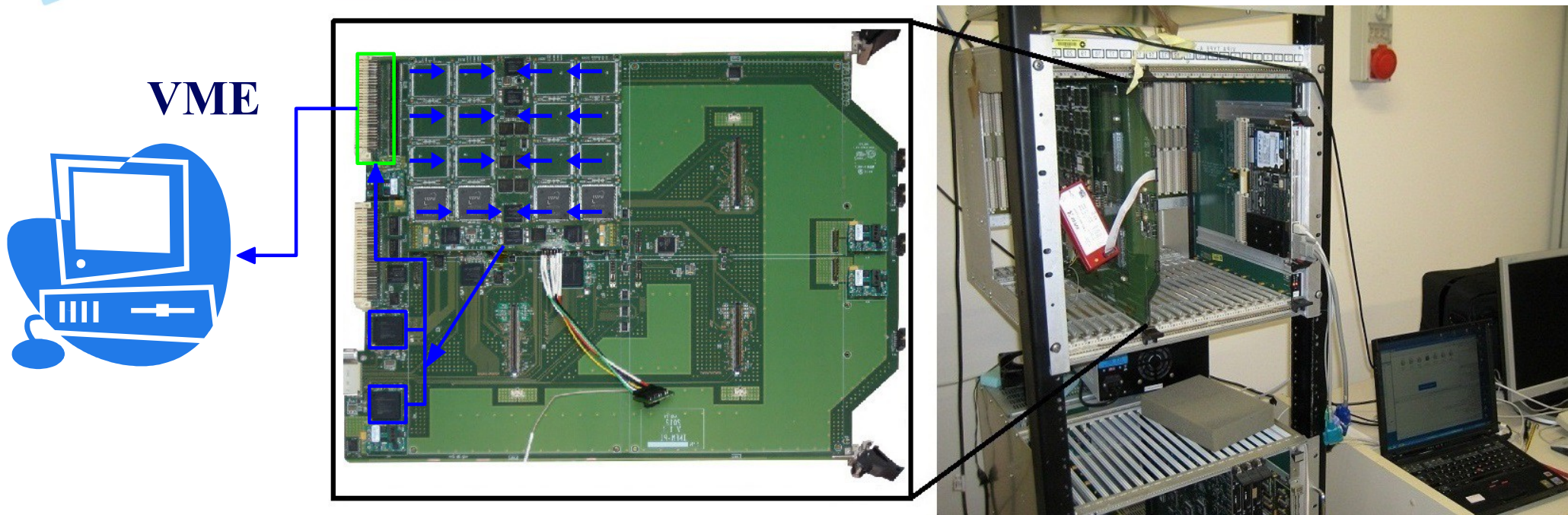

- Step 1: Store precalculated Patterns into Associative memory chips:
  - Through VME the data are stored in the AM by FPGA (yellow arrows)
- Step 2: Simulate silicon HITS Input:
  - Silicon HITS Input are loaded into the inputs FPGAs memory (red square) through VME.
  - The FPGAs transmits data to the LAMBs at full speed.
- Step 3: Check pattern matching:
  - Collect ROADS in the Output FPGAs (blue squares).
  - Compare Hardware and Simulation output.

# Cooling Tests

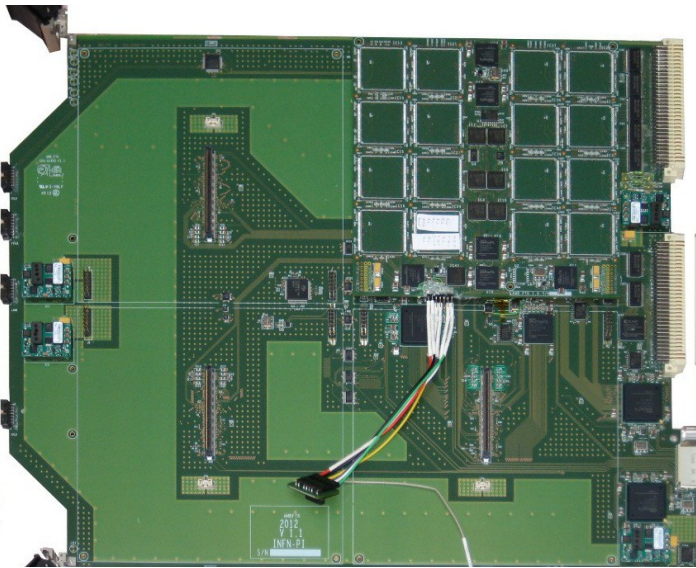

Expected power consumption  
1 Processing unit ~ 300 Watt.

16 PU per crate (plus SSB, CPU)

5 kW per crate.

Need Cooling test!

Power supply voltages:

- 5V
- 3,3V
- 1,2V

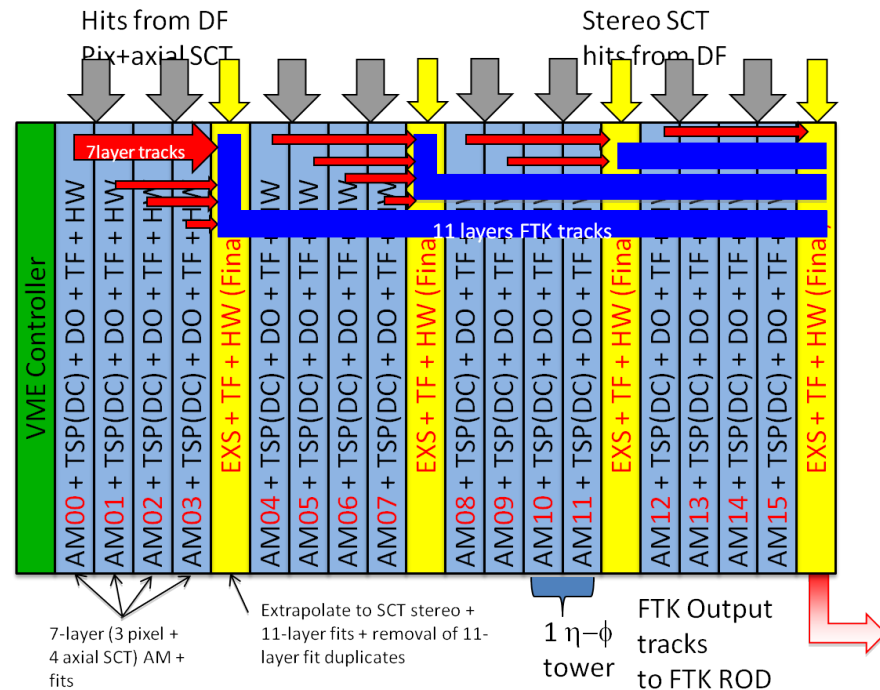

# Cooling Tests without chiller

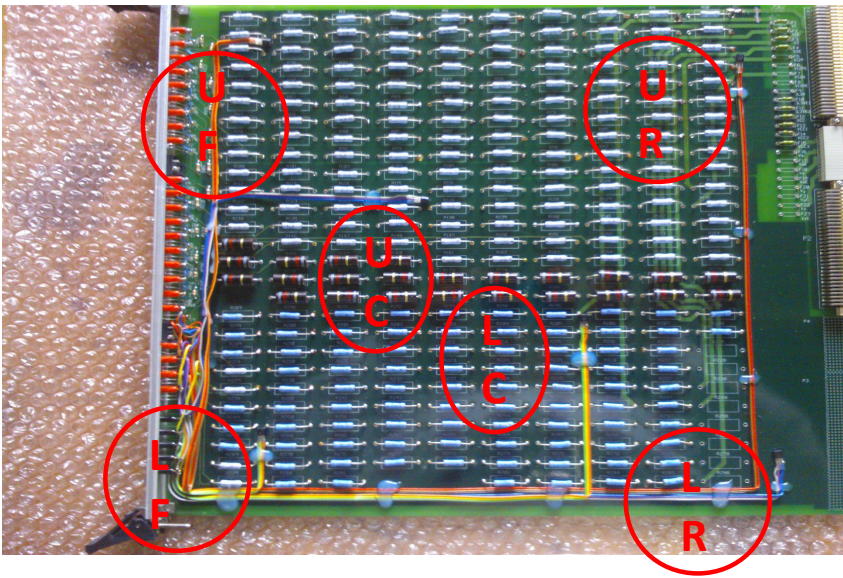

- Cooling test work in progress INFN PAVIA.
- Power consumption simulated with resistors.
- Six sensor used to measure the temperature in the crate (red circles)

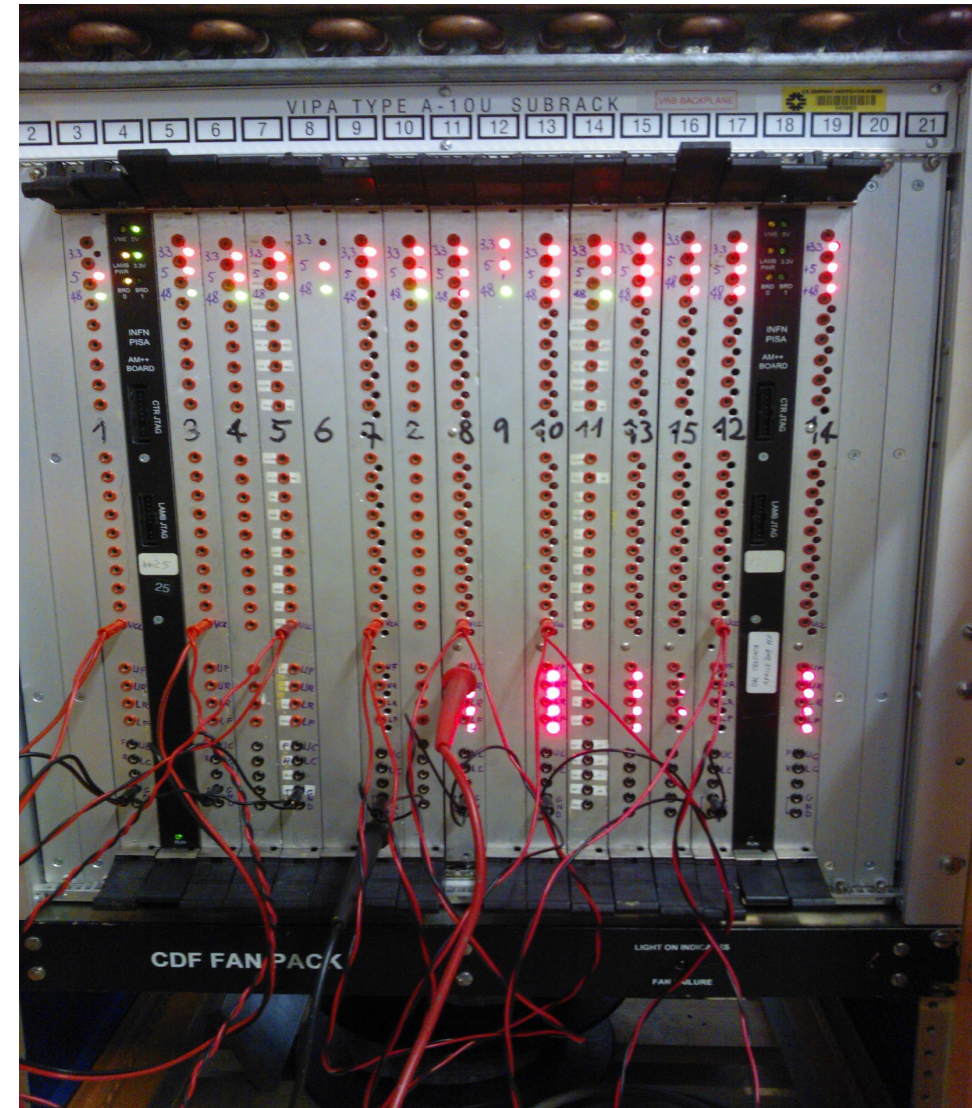

# Cooling Tests Result without chiller

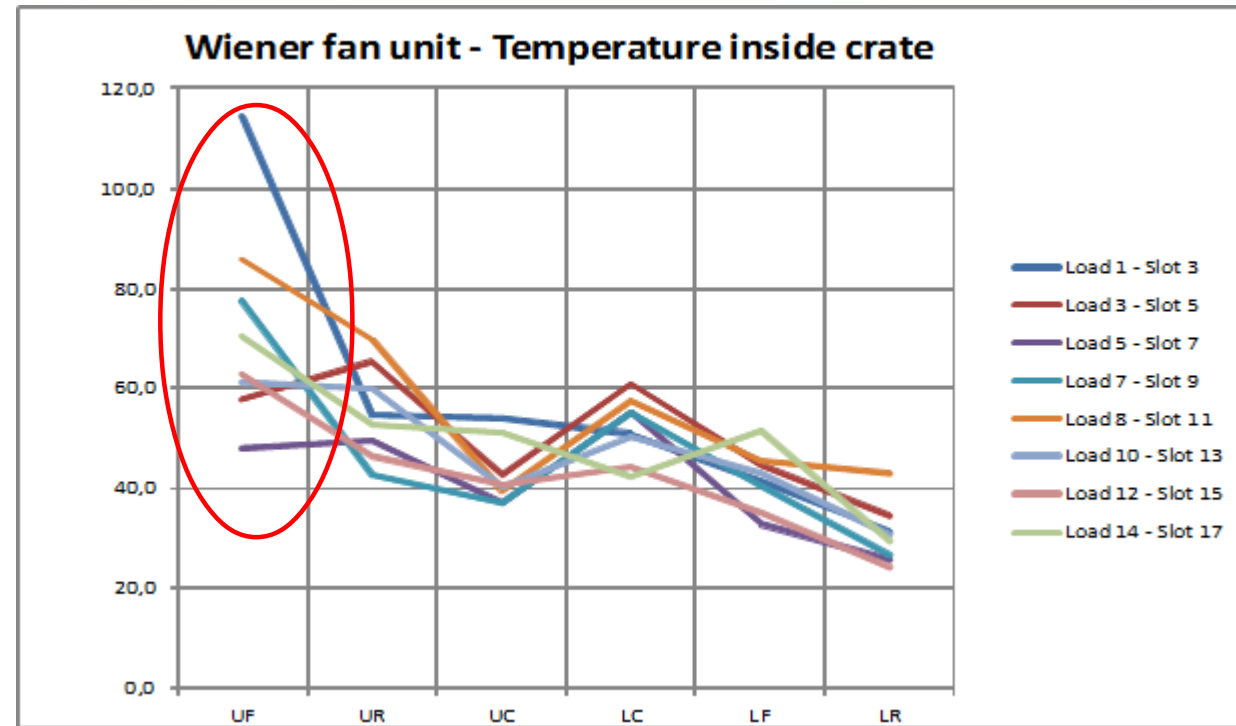
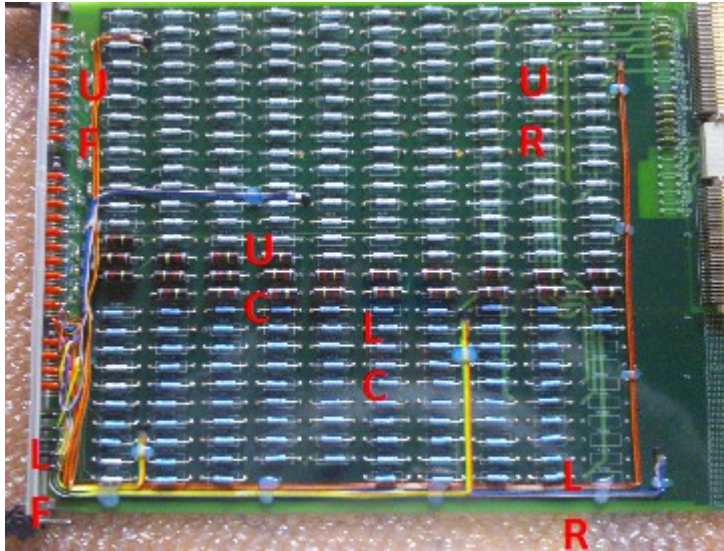

- With the Wiener Fan we have a peak of temperature in the up side of crate.
- The reason is the power of the fans.

# Cooling Tests Result without chiller

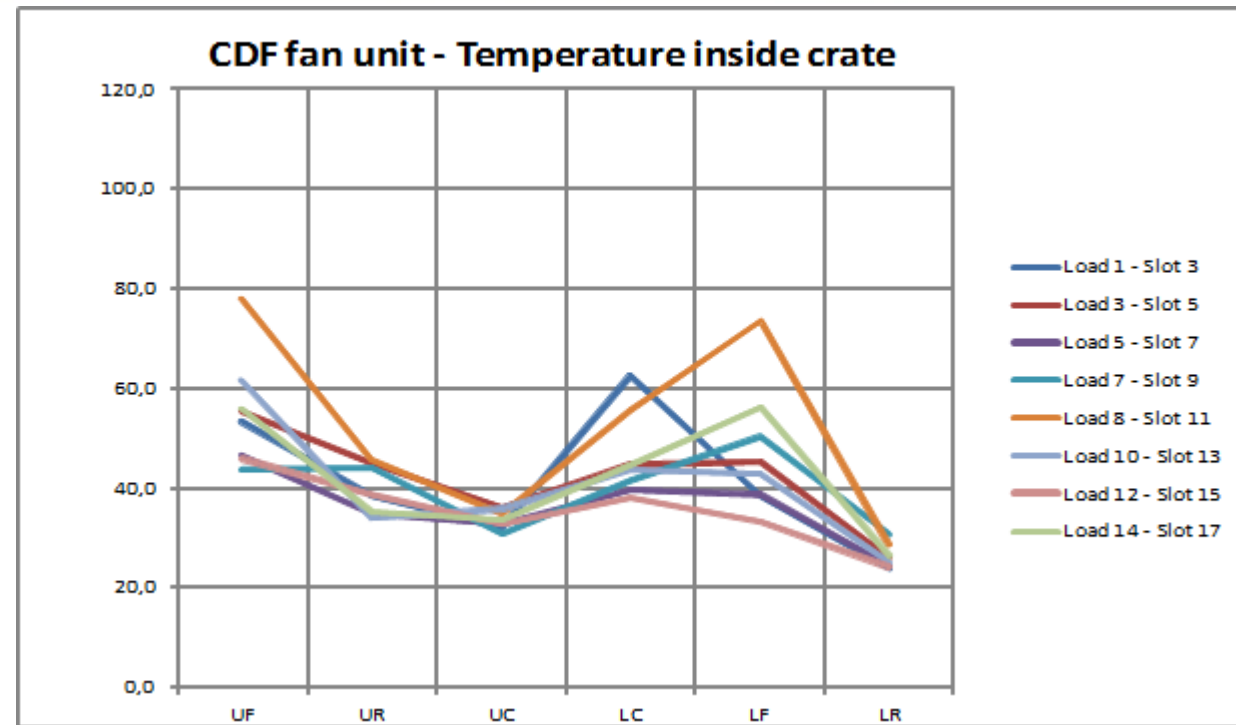
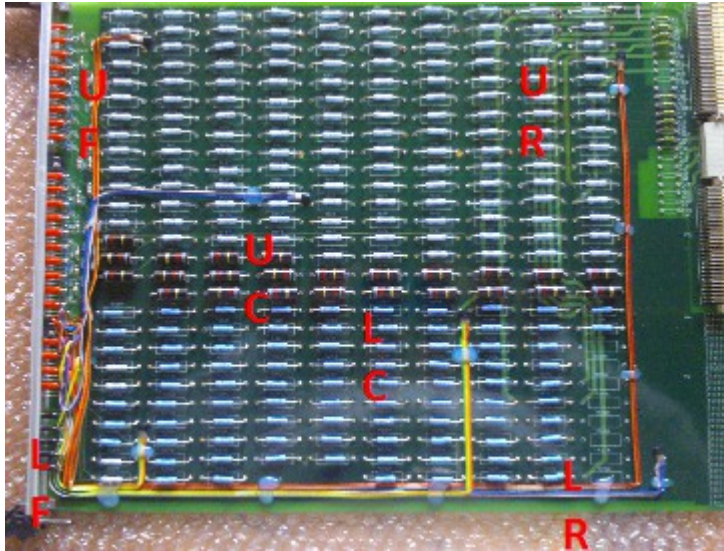

- With CDF Fan the temperature is lower but there is a peak in the down front side of crate.
- The reason is the missing fan.
- Cooling test are in progress: next step is to resolve the problem with fans and use the chiller.





## Conclusion

- AM system test results were excellent.
- Cooling test are in progress.
- Now we are improving the system for the final version.
- June 21, 013: ATLAS Collaboration Board approved the FTK Technical Design Report.
- We will install the system for the next LHC power on, in 2015.

A decorative graphic in the top-left corner consisting of several overlapping, semi-transparent squares and circles in various shades of light blue. The shapes are arranged in a cluster, with some squares containing smaller squares or circles inside them, creating a layered, geometric effect.

Thank You!

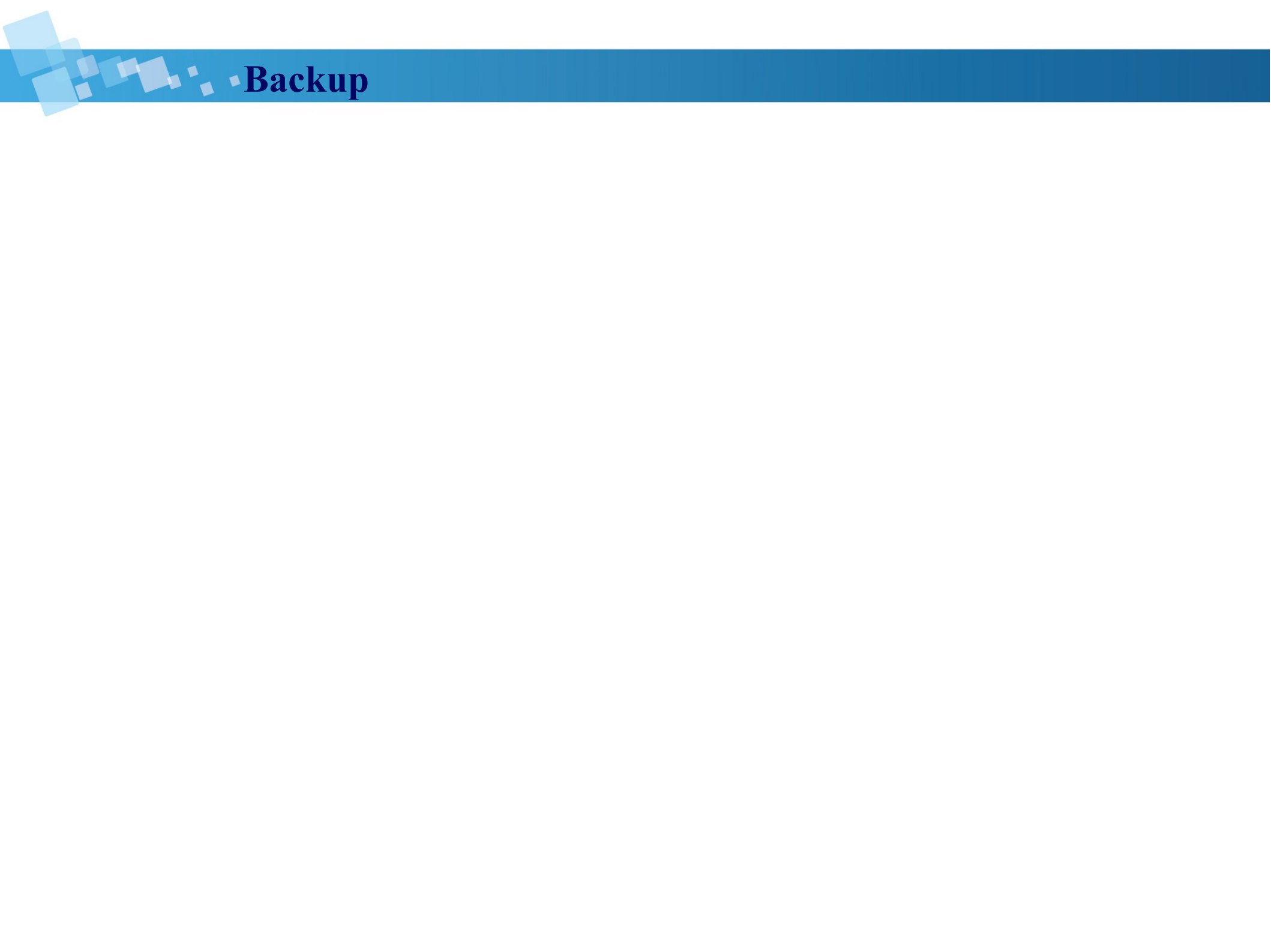

# Backup