



CERN-ACC-2013-0267

Alessio.mereghetti@cern.ch

Report

Energy Deposition Studies for the Upgrade of the LHC Injection Lines

A. Mereghetti

CERN, Geneva, Switzerland, and University of Manchester, UK

O. Aberle, F. Cerutti, B. Goddard, V. Kain, F. L. Maciariello, M. Meddahi,

CERN, Geneva, Switzerland

E. Gianfelice-Wendt, Fermilab†

Batavia, IL, USA

R. B. Appleby

University of Manchester, UK

Keywords: Colliders, Beam Injection

Abstract

The LHC Injectors Upgrade (LIU) Project aims at upgrading the systems in the LHC injection chain, to reliably deliver the beams required by the High-Luminosity LHC (HL-LHC). Given the challenging beam intensities and emittances, a review of the existing beam-intercepting devices is on-going, in order to assess heat loads and consequent thermo-mechanical stresses. Moreover, the exposure of downstream elements to induced shower radiation is assessed. The study is intended to spot possible issues and contribute to the definition of viable design and layout solutions.

Presented at: IPAC13, 12-17 May 2013, Shanghai, China

Geneva, Switzerland
June, 2013



ENERGY DEPOSITION STUDIES FOR THE UPGRADE OF THE LHC INJECTION LINES

A. Mereghetti*, CERN, Geneva, Switzerland, and Univeristy of Manchester, UK
 O. Aberle, F. Cerutti, B. Goddard, V. Kain, F. L. Maciariello, M. Meddahi,
 CERN, Geneva, Switzerland
 E. Gianfelice-Wendt, Fermilab†, Batavia, IL, USA
 R. B. Appleby, University of Manchester, UK

Abstract

The LHC Injectors Upgrade (LIU) Project aims at upgrading the systems in the LHC injection chain, to reliably deliver the beams required by the High-Luminosity LHC (HL-LHC). Given the challenging beam intensities and emittances, a review of the existing beam-intercepting devices is on-going, in order to assess heat loads and consequent thermo-mechanical stresses. Moreover, the exposure of downstream elements to induced shower radiation is assessed. The study is intended to spot possible issues and contribute to the definition of viable design and layout solutions.

INTRODUCTION

The High Luminosity LHC (HL-LHC) Project [1] aims at increasing the peak LHC luminosity by a factor of 10 beyond its design value. This upgrade is intended to be achieved by improving the machine optics and the beam quality from the injectors. The LHC Injectors Upgrade (LIU) Project [2] is in charge of the latter, upgrading the systems in the LHC injection chain necessary to reliably deliver the required beams. The LIU beam parameters for 25 ns bunch spacing at extraction in the Super Proton Synchrotron (SPS) considered in the present work are shown in Table 1 for the Q20 optics, only recently preferred to the Q26 one, indicated as well. Values presently available in SPS (November 2012) [3] and those of the Nominal LHC at injection [4] are reported for comparison. It should be noted that while the Nominal LIU beam parameters give rise to the smallest beam spot sizes, those of Maximum LIU are featured by the highest bunch population.

Due to the improved beam parameters, the beam-intercepting devices presently installed may not stand the challenging levels of heat load [5]. Fluka [6, 7] simulations were thus carried out to estimate expected values of energy deposition, and, if needed, help the design of new systems. The assessment involves also the coils of downstream magnets and the masks protecting them, whenever required. The present study is mainly focussed on the LHC injection lines TI2 and TI8 (“Tunnel d’Injection”).

Table 1: LIU beam parameters for 25 ns bunch spacing at extraction in the SPS, along with the present ones, and Nominal LHC values at injection.

	bunch intensity [10 ¹¹]	$\epsilon_{x,y}^N$ [μm] (1 σ_{rms})	$\sigma_{\Delta p/p}$ [10 ⁻⁴]	
			Q20	Q26
Nom LIU	1.15	1	1.31	1.68
Max LIU	2.5	2.5	5.25	6.8
present	1.7	1.5	-	2
Nom LHC	1.15	3.5	-	3.1

BEAM-INTERCEPTING DEVICES IN THE LHC INJECTION LINES

In case of extraction set-up or intervention in the TI2 or TI8 tunnels, TED (see Fig. 1) [8] dumps are inserted onto the main beam line. They are featured by a multi-material structure as inner absorber (see Table 2), optimised on the basis of beam absorption and activation, surrounded by an outer iron layer, with shielding purposes.

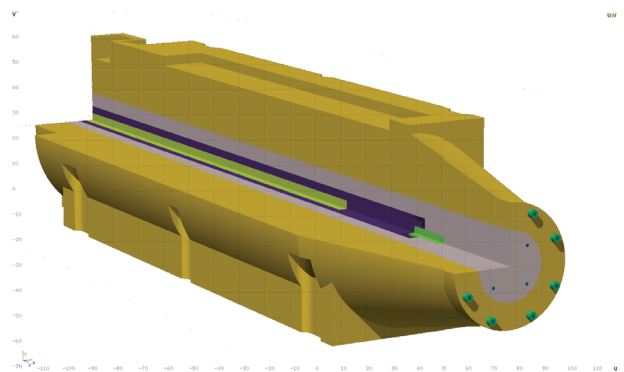

Figure 1: 3D rendering [9] of the Fluka geometry of the TED. View from the downstream side. The geometry has been cut, to show the inside.

During regular operation, the protection of the LHC against beam mis-steering and magnet failures is ensured by TCDI [8] collimators, installed towards the end of the TI2 and TI8 injection lines. They are arranged in a three phases collimation scheme for each plane and line. Their jaws are made of graphite R4550 Steinemann (its physical properties relevant for the Fluka calculations are very

* alessio.mereghetti@cern.ch

† Operated by Fermi Research Alliance, LLC under contract No. DE-AC02-07CH11359 with the U.S. DOE.

Table 2: Material properties of the TED inner absorber: length, density, inelastic scattering length for protons at 450 GeV/c, and radiation length. Materials are ordered from the entrance window to the dump end.

	l [m]	ρ [g cm ⁻³]	λ_I [cm]	X_0 [cm]
graphite	2.9	1.8	45.3	23.7
aluminum	0.6	2.7	38.2	8.8
copper	0.8	8.9	14.7	1.4

similar to those reported for graphite in Table 2), with no water cooling. Between each TCDI collimator and the downstream magnet, metallic masks (TCDIMs) of 0.5 m of length are installed, for shielding purposes.

In the framework of the LIU project, the TED dumps are kept in their present locations, whereas a new set of collimators is envisaged upstream of the present ones, in order to prevent Beam Loss Monitors (BLMs) around the LHC from triggering beam dumps during regular injection. The new collimation system implements the same phase advance scheme as the one presently adopted. Metallic masks should be mounted downstream of each new collimator. Whenever possible, the overall design of the present devices should be reused, unless energy deposition studies point out the need of a new one.

ENERGY DEPOSITION STUDIES

Figure 2 shows the maxima of energy deposition in the TCDI jaws directly impacted by the beam. Only the first collimator out of three per plane and line was considered, since it is featured by the smallest values of the β function, and it is the most likely to be impacted by a mis-steered beam. The optics matched with SPS Q26 was systematically used, whereas only the smallest beam sizes were picked up from the optics matched to SPS Q20. Values in case of Maximum LIU beam parameters reflect the larger beam sizes and the higher bunch population with respect to those in case of Nominal LIU. As expected, the loads for the 5σ impact parameter are higher than those for the 1σ . The patterns are compatible with an inverse dependence upon the beam size. The same figure shows also the maxima of energy deposition in the graphite layer of the TED inner absorber when directly impacted by the beam, with the smallest sizes among the SPS Q26 and Q20 optics.

The related temperature increase is at least $\sim 1250^\circ\text{C}$ and $\sim 1450^\circ\text{C}$ in the TCDI jaws and TED graphite layer, respectively, in the worst cases: despite clearly below the melting temperature, further thermo-mechanical analyses performed with the Ansys code showed that the induced stresses are too high for a reliable operation of the devices. The search for a new material converged towards CfC carbon-fibers at 1.7 g cm^{-3} .

The new design of the inner absorber of the TED dump has thus just started, featuring this material as first layer.

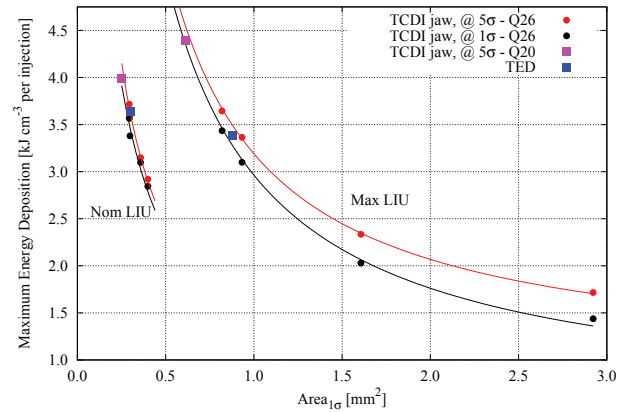

Figure 2: Maxima of energy deposition as a function of the beam size for different cases of protons impinging onto a TCDI jaw, and onto the first graphite layer of the TED dump. Statistical uncertainties are smaller than the spot size. Beam sizes take into account the contribution from the dispersion. Values are scaled to a train of 288 bunches.

Other layers of different materials should be added and optimised, in order to guarantee adequate absorption capabilities in the same available space, limit the induced activation, and preserve the integrity of the structure, especially in case of the more populated Maximum LIU beams.

In order to dilute the beam enough below the damage limit of $2.3 \cdot 10^{12}$ protons [10], two consecutive modules of TCDI collimators featuring CfC carbon-fibers as jaw material could be installed in each chosen location.

The total load onto the TCDI jaw impacted by the beam is ~ 170 kJ per bunch train in the worst case, whereas the total load onto the TED dump is ~ 5 MJ per bunch train, of which 1 MJ in the graphite layer.

Downstream of the TCDI Collimators

In order to evaluate the energy deposition onto the masks and the coils of the magnets downstream of the new TCDI collimators, Fluka geometries spanning over some tens of meters of beam line were needed. Novel Fluka geometries of the most relevant elements were modelled into the Fluka Element DataBase (FEDB) [11], and the portions of line of actual interest were thus automatically created by means of the Line Builder [11]. An example of such geometries is shown in Fig. 3. This approach was particularly useful, since the orbit plane continuously changes along the LHC injection lines by tiny angles.

Figure 4 shows the maxima of energy deposition in the protecting mask (upper frame) and in the coils of the protected quadrupole (lower frame) as a function of the distance from the collimator just upstream, in cases of a Maximum LIU proton beam impinging onto a TCDI jaw. Only the impact on the first collimator per plane and line was considered, with the optics matched with SPS Q26. Two sets of values are shown, with the one for the 5σ beam impact parameter being constantly above the one for 1σ , as expected, since more primary protons contribute to sec-

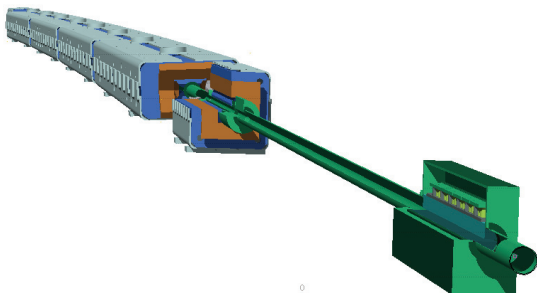

Figure 3: 3D rendering [9] of the portion of the TI8 injection line between the TCDIV.NEW1 (in foreground) and the MQIF.87600 (the last shown magnet, after the four main dipoles), looking downstream. The TCDI collimator and the downstream mask and quadrupole have been cut to show the inside.

ondary particle showers. The special case of the Maximum LIU beam impacting the TCDIH.29465, the last horizontal collimator presently installed in TI2, is shown for comparison, since the distance to the downstream magnet is the shortest one, thus maximising the peak energy deposition.

The temperature increase in the TCDIM masks is $\sim 400^\circ\text{C}$ at most, for the very unlikely case of a beam impact onto the TCDIH.29465 collimator, with a total load of 800 kJ per bunch train. The masks effectively shield the downstream quadrupoles, allowing a maximum temperature increase in the coils of 10°C and a total load on the entire magnet of about 700 kJ per bunch train, in that same unlikely case.

CONCLUSIONS

Fluka studies have shown that beam-intercepting devices presently installed in the LHC injection lines do not stand the challenging heat loads induced by the improved beam parameters required by the HL-LHC project: maxima of energy deposition reach a few kJ cm^{-3} per bunch train, inducing too high thermo-mechanical stresses. CfC carbon-fibers are presently considered as baseline material to be exposed to the direct impact of the beam.

The extensive use of metallic masks protecting magnets just downstream of the TCDI collimators ensures a temperature increase in the normal-conducting coils of some degrees Celsius, with a moderate load onto the masks themselves.

REFERENCES

[1] hilumilhc.web.cern.ch
 [2] espace.cern.ch/liu-project
 [3] K. Cornelis and G. Rumolo, private communication.
 [4] "LHC Design Report" vol. 1, O. Brüning et al. eds., CERN-2004-003.
 [5] O. Mete et al., "Upgrades of the SPS, Transfer Line and LHC Injection Protection Devices for the HL-LHC Era", MOPFI053, these proceedings.

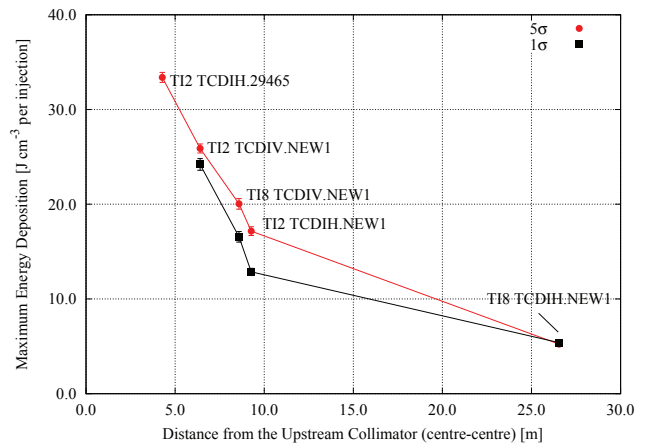
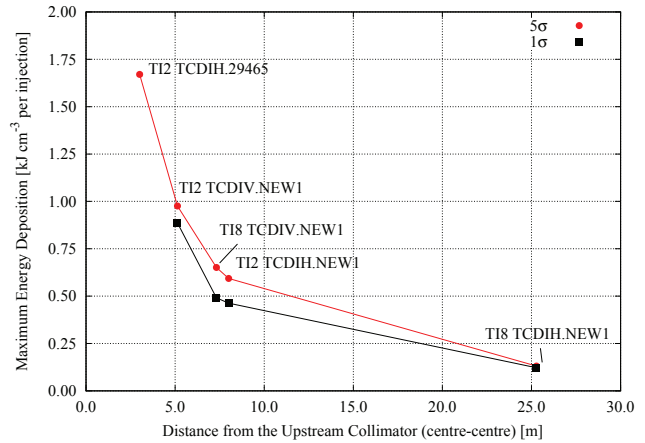

Figure 4: Maxima of energy deposition in the protecting TCDIM mask (upper frame) and in the coils of the protected quadrupole (lower frame) as a function of the distance from the upstream collimator, in cases of a Maximum LIU proton beam impacting a TCDI jaw. Whenever not visible, statistical uncertainties are smaller than the spot size. Values are scaled to a train of 288 bunches.

[6] A. Fassò et al., "FLUKA: a Multi-Particle Transport Code", CERN-2005-10, INFN/TC-05/11, SLAC-R-773.
 [7] G. Battistoni et al., "The FLUKA code: Description and Benchmarking", Proc. of the Hadronic Shower Simulation Workshop 2006, Fermilab 6th-8th September 2006, M. Al-brow, R. Raja eds., AIP Conf. Proc. 896, p. 31, 2007.
 [8] "LHC Design Report" vol. 3, M. Benedikt et al. eds., CERN-2004-003.
 [9] V. Vlachoudis, "FLAIR: A Powerful But User Friendly Graphical Interface For FLUKA", Proc. of the International Conference on Mathematics, Computational Methods and Reactor Physics (M&C 2009), Saratoga Springs, New York, 2009.
 [10] B. Jeanneret, "Collimation Schemes and Injection Protection Devices in LHC", Proc. of the 11th Chamonix Workshop - LEP-SPS performance, Chamonix, January 2001, p. 298 (2001).
 [11] A. Mereghetti et al., "The FLUKA LineBuilder and Element DataBase: Tools for Building Complex Models of Accelerator Beam Lines", IPAC2012, New Orleans, May 2012, WEPPD071, p. 2687 (2012), www.JACoW.org