

DYNAMICS AND ACCELERATION IN LINEAR STRUCTURES

J. Le Duff

Laboratoire de l'Accélérateur Linéaire
Université Paris-Sud, 91405 Orsay, France

Contents

- I. Basic Methods of Linear Acceleration
- II. Fundamental parameters of accelerating structures
- III. Energy gain in linear accelerating structures
- IV. Particle dynamics in linear accelerators

I. BASIC METHODS OF LINEAR ACCELERATION

I.1 - EARLY DAYS

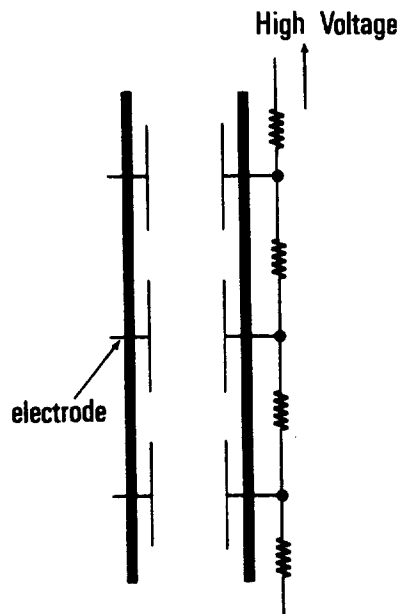

In principle a linear accelerator is one in which the particles are accelerated on a linear path. Then the most simple scheme is the one which uses an electrostatic field as shown on Fig. 1. A high voltage is shared between a set of electrodes creating an electric accelerating field between them. The disadvantage of such a scheme, as far as high energies are concerned, is that all the partial accelerating voltages add up at some point and that the generation of such high electrostatic voltages will be rapidly limited (a few ten MV). This type of accelerator is however currently used for low energy ion acceleration, and better known as VAN DE GRAAFF accelerator.

Fig. 1 - Electrostatic accelerator scheme

Late 1920's propositions were made, essentially by R. WIDEROE, to avoid the limitation of electrostatic devices due to voltage superposition. The proposed scheme, later on (early 1930's) improved by E. LAWRENCE and D. SLOAN at the Berkeley University, is shown on Fig. 2.

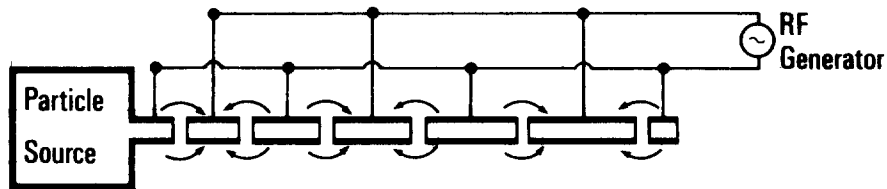

Fig. 2 - WIDEROE type accelerator

An oscillator (7 MHz at that time) feeds alternately a series of drift tubes in such a way that particles see no field when travelling inside these tubes while they are accelerated in between. The last statement is true if the drift tube length L satisfies the synchronism condition :

$$L = \frac{vT}{2}$$

where v is the particle velocity (βc) and T the period of the a.c. field. This scheme does not permit to accelerate continuous beams of particles.

I.2 - IMPROVED METHODS FOR NON RELATIVISTIC PARTICLES

Consider a proton of 1 MeV kinetic energy entering the previous structure. At a frequency of 7 MHz such a particle, with $\beta = v/c = 4.6 \cdot 10^{-2}$, will travel a distance of roughly 1 meter in half a cycle. Clearly the length of the drift tubes will soon become prohibitive at higher energies unless the input RF frequency is increased.

Higher frequency power generators only became available after the second world war, as a consequence of radar developments.

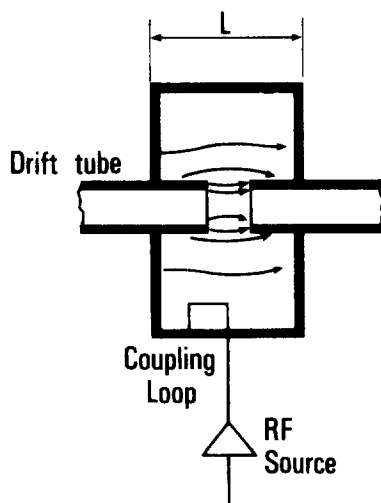

Fig. 3 - Single-gap accelerating structure

However at higher frequencies the system, which is almost capacitive, will radiate a large amount of energy ; as a matter of fact if one considers the end faces of the drift tubes as the plates of a capacitor, the displacement current flowing through it is given by

$$I = \omega CV$$

where C is the capacitance between the drift tubes, V the accelerating voltage and ω the angular frequency in use. It is therefore convenient to enclose the gap existing between drift tubes in a cavity which holds the electromagnetic energy in the form of a magnetic field (inductive load) and to make the resonant frequency of the cavity equal to that of the accelerating field (Fig. 3). In that case the accelerator would consist in a series of such cavities

fed individually with power sources.

Such single-gap cavities could also be placed adjacent to each other as shown on Fig. 4.

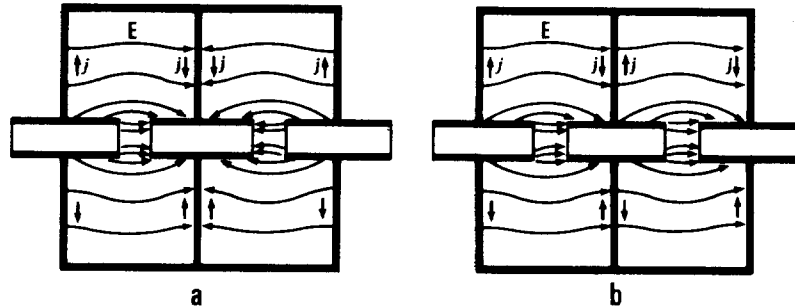

Fig. 4 - Adjacent single-gap cavities :
 a) π mode b) 2π mode

In the 2π mode case, since the resulting wall current is zero, the common walls between cavities become useless. Then a variant of that scheme consists of placing the drift tubes in a single resonant tank such that the field has the same phase in all gaps. Such a

resonant accelerating structure was invented by L. ALVAREZ in 1945 and followed by the construction of a 32 MeV proton drift tube linac (Fig. 5) powered by 200 MHz war surplus radar equipment.

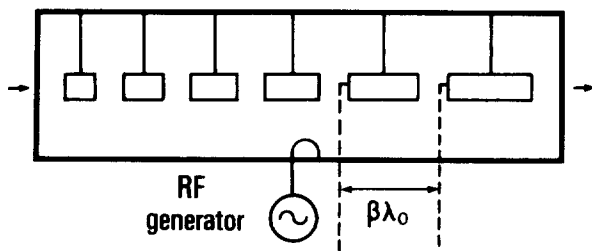

Fig. 5 - ALVAREZ type structure

In the 2π mode of operation the synchronism condition is :

$$L = vT = \beta\lambda_0$$

where λ_0 is the free space wavelength at the operating frequency. Notice that on Fig. 5 the drift tubes are maintained by metallic rods to the tank walls.

The ALVAREZ structure is still used for protons, as well as heavy ions, operating mostly at 200 MHz. Most of our present days proton linear accelerators are used as injectors for circular machines such as synchrotrons and their energy lies from 50 MeV to 200 MeV. At 200 MeV protons are still weakly relativistic with $\beta = 0.566$.

Note : Since the progress in methods of acceleration came from the use of resonant structures which can provide high accelerating field with less power consumption, the new definition of a linear accelerator or "Linac" implied machines in which particles are accelerated on a linear path by radio frequency fields. Then electrostatic devices no more appear in this definition, but it is worthwhile mentioning that they are used as front end proton linacs.

I.3 - THE CASE OF ULTRA-RELATIVISTIC PARTICLES

While β is getting close to unity for protons of 10 GeV kinetic energy, β is almost unity for electrons of 10 MeV. Hence above these energies the particles will have a constant velocity $v = c$ and the length of the drift tubes will remain constant as well. The higher velocity needs higher frequencies. However triode and tetrode tubes could not handle high RF power at high frequency. The invention of the klystron in 1937 and its successful development during the war led to high power sources at 3000 MHz. At this frequency the free space wavelength is 10 cm, small enough that the perspective of accelerating electrons to high energies soon became an aim.

At the same time emerged the idea that ultrarelativistic particles could be accelerated by travelling guided waves. It is a matter of fact that in a resonant structure the standing wave pattern can be expanded into two travelling waves, one which travels in synchronism with the particle and the backward wave which has no mean effect on the particle energy.

However TM modes (with an electric field in the direction of propagation) in rectangular or cylindrical guides have phase velocities bigger than c . Then it was necessary to bring the phase velocity at the level of the particle velocity ($v_p \sim c$) and to do so the simplest method consists of loading the structure with disks as shown on Fig. 6, where the size of the holes determines the degree of coupling and so determines the relative phase shift from one cavity to the next. When the dimensions ($2a$, $2b$) have been tailored correctly the phase changes from cavity to cavity along the accelerator to give an overall phase velocity corresponding to the particle velocity.

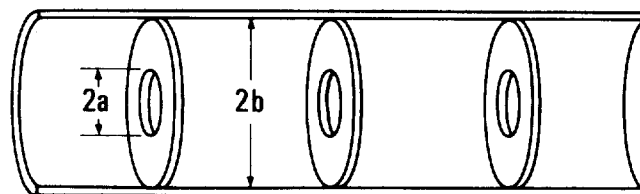

Fig. 6 - Disk-loaded structure

This type of structure will continuously accelerate particles as compare to the drift tube structure which gives a discontinuous acceleration corresponding to the successive gaps.

Fig. 7 is a more complete drawing of such a travelling-wave structure showing both, the input coupler which matches the source to the structure and the output coupler which matches the structure to an external load (resistive load for instance) to avoid the backward wave.

These structures generally operate in the $\pi/2$ mode or the $2\pi/3$ mode. For the former the height of each cell is equal to $\lambda/4$ while it is equal to $\lambda/3$ for the latter. This is important, as will be seen later, for the electromagnetic energy to propagate. The interesting thing with travelling-wave structures, in which the energy propagates relatively fast, is that the RF power source can be pulsed during a short period corresponding to the filling time of the structure. In this pulsed mode of operation much higher peak power pulses can feed the structure, increasing the accelerating field. As a consequence only pulsed beams can

be accelerated leading to small duty cycles.

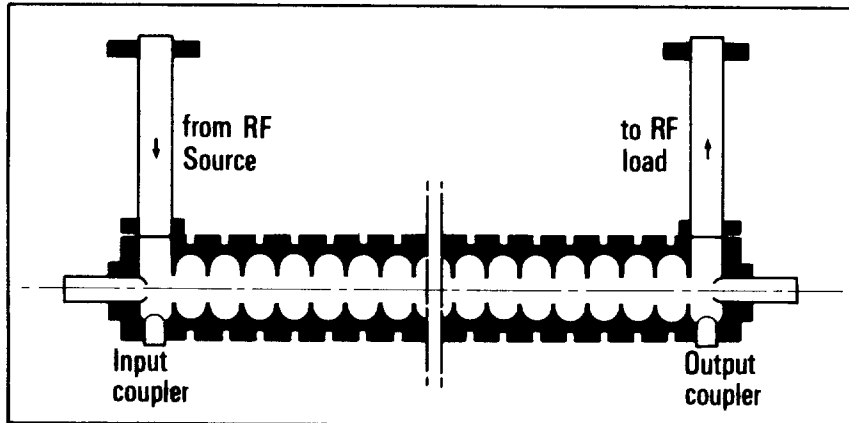

Fig. 7 - Travelling wave accelerating structure

Standing wave structures can also be used for ultrarelativistic particles. In that case the π mode of operation is efficient, where the field has opposite phase in two adjacent cells. This type of structure as shown on Fig. 8 often called "nose cone structure" is very similar to the drift tube one in which the length of the tubes has been made very small. A variant of this scheme is used in the high energy proton linac ($E = 800$ MeV) at Los Alamos, where the coupling between cavities has been improved by adding side coupled resonant cavities as sketched on Fig. 9.

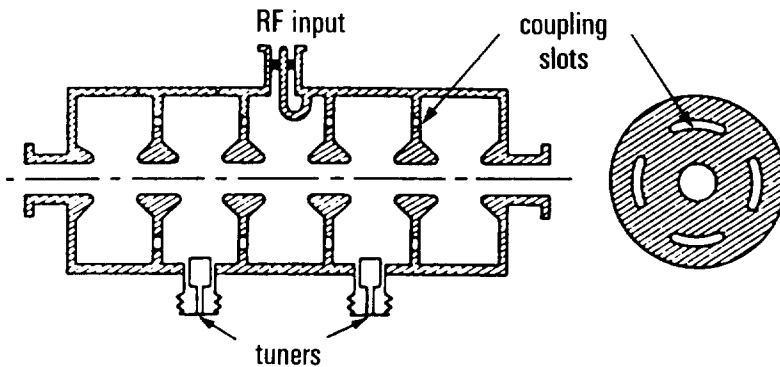

Fig. 8 - Nose cone structure

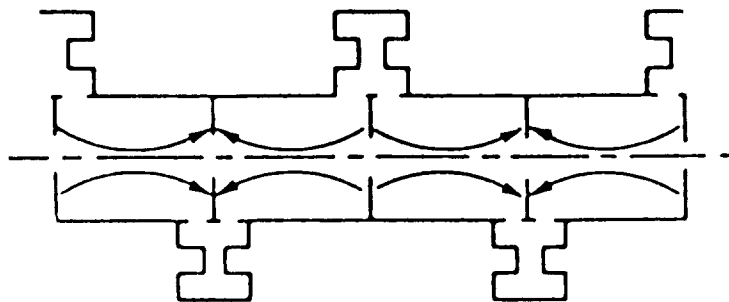
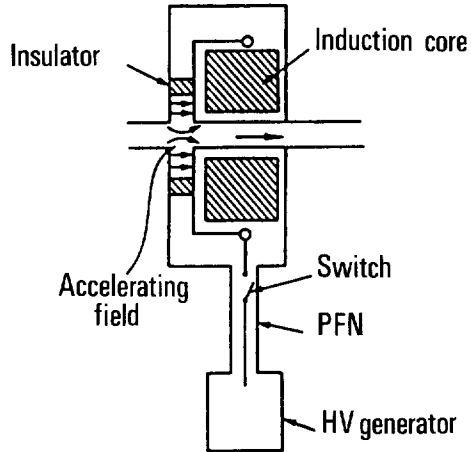

Fig. 9 - Side coupled structure

I.4 - INDUCTION LINAC

Resonant structures as described previously cannot handle very high beam currents. The reason is that the beam induces a voltage proportional to the circulating current and with a phase opposite to that of the RF accelerating voltage. This effect known as "beam loading" disturbs the beam characteristics and can even destroy the beam by some instability mechanism.



A cure for such an effect in the case of very high currents consists of producing an accelerating field with a very low Q resonator. This is obtained with an induction accelerator module (Fig. 10) in which a pulsed magnetic field produces an electric field component, according to Maxwell equations, just similar to the betatron principle.

The accelerator will consist of an array of such modules triggered at a rate compatible with the particle velocity, and fed by high power short pulse generators.

Fig. 10 - Linear induction accelerator module

I.5 - RADIO FREQUENCY QUADRUPOLE (RFQ)

At quite low β values (for example low energy protons) it is hard to maintain high currents due to the space charge forces of the beam which have a defocussing effect.

In 1970 I.M. KAPCHINSKI and V.A. TEPLYAKOV from Soviet Union proposed a device in which the RF fields which are used for acceleration can serve as well for transverse focussing. The schematic drawing of an RFQ is shown on Fig. 11. The vanes which have a quadrupole symmetry in the transverse plane have a sinusoidal shape variation in the longitudinal direction. In recent years these devices have been built successfully in many laboratories making it possible to lower the gun accelerating voltage for protons and heavy ions to less than 100 KV as compare to voltages above 500 KV which could only be produced earlier by large COCKROFT-WALTON electrostatic generators.

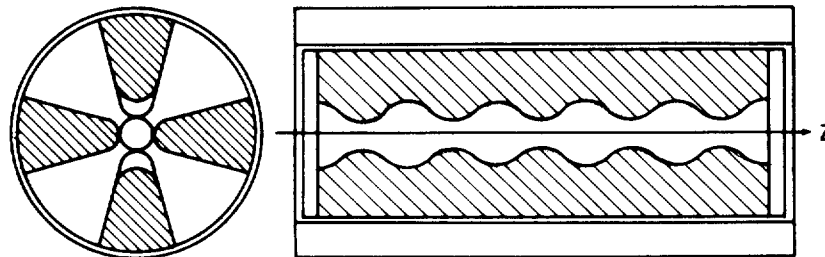

Fig. 11 - Schematic drawing of an RFQ resonator

I.6 - OTHER METHODS AND FUTURE PROSPECTS

Among the other methods of acceleration one can at least distinguish between two classes : collective accelerators and laser accelerators. In both cases the idea is to reach much higher gradients in order to produce higher energies keeping the overall length of the accelerator at a reasonable level.

Collective accelerators are already in use for ion acceleration but up to now they never reached the desirable high gradients. The oldest idea of collective acceleration is the Electron Ring Accelerator (ERA) where an intense electron beam of compact size is produced in a compressor (Fig. 12). The electron ring is then accelerated either by an electric field or by a pulse magnetic field (induction acceleration) and loaded with ions. Through space charge effect the electron (hollow beam) will take the ions along.

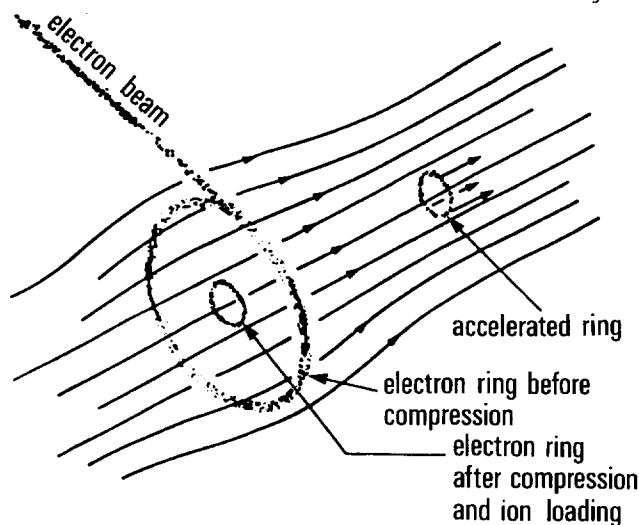

Fig. 12 - Principle of the Electron Ring Accelerator (ERA)

Laser accelerators hold out the promise of reaching high energies with a technology which is new to accelerator physicists. Plasma media can be used to lower the velocity of the laser wave.

It is also worthwhile to mention that the extension of conventional techniques are also studied extensively for very high energy electron linacs.

II. FUNDAMENTAL PARAMETERS OF ACCELERATING STRUCTURES

II.1 - TRANSIT TIME FACTOR

Consider a series of accelerating gaps as in the ALVAREZ structure (Fig. 13a) and assume the corresponding field in the gap to be independent of the longitudinal coordinate z (Fig. 13.b). If V is the maximum voltage in the gap, the accelerating field is :

$$E_z = \frac{V}{g} \cos \omega t$$

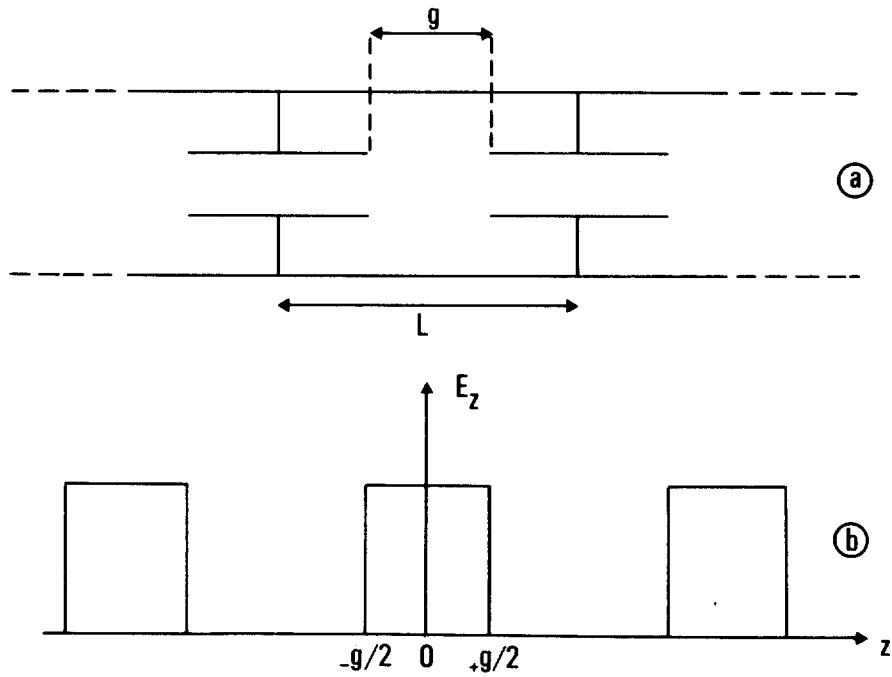

Fig. 13 - Approximate field pattern in a drift tube accelerator

If the particle passes through the center of the gap at $t = 0$ with a velocity v , its coordinate is :

$$z = vt$$

and its total energy gain is :

$$\begin{aligned} \Delta E &= \int_{-g/2}^{+g/2} \frac{eV}{g} \cos \omega \frac{z}{v} dz \\ &= eV \frac{\sin \theta/2}{\theta/2} = eVT \end{aligned}$$

where $\theta = \frac{\omega g}{v}$ is called the transit angle and T is the transit time factor :

$$T = \frac{\sin \theta/2}{\theta/2}$$

For a standing-wave structure operating in the 2π mode and where the gap length is equal to the drift tube length :

$$g = \beta \lambda_0/2$$

one gets :

$$T = .637$$

To improve upon this situation, for a given V it is advantageous to reduce the gap length g which leads to larger drift tubes as in the ALVAREZ design. However a too large reduction

in g will lead to sparking, for a given input power per meter, due to an excessive local field gradient. Usual values of T lie around .8. In the more general case where the instantaneous field is not homogeneous through the gap, the transit time factor is given by :

$$T = \frac{|\int E_z(z) e^{j\omega t} dz|}{\int E_z(z) dz}$$

The transit time factor generally shows the amount of energy which is not gained due to the fact that the particle travels with a finite velocity in an electric field which has a sinusoidal time variation. However this factor may become meaningless, for instance if the mode is such that the denominator is equal to zero while the numerator remains finite as would be the case for a TM_{011} mode in a pill-box cavity (see Fig. 14). So one has to be careful when using this concept.

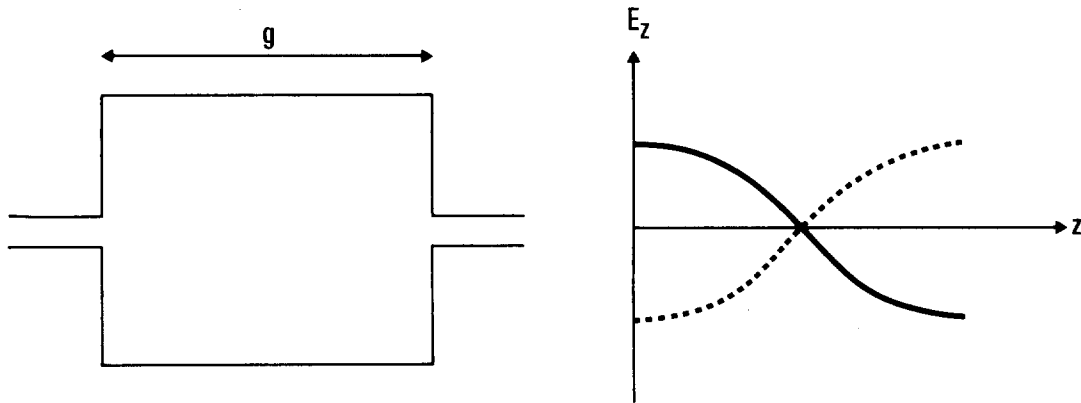

Fig. 14 - TM_{011} mode in a pill-box cavity

Exercise : Energy gain when the field E_z in the gap varies with z :

One has :

$$\Delta E = e \Re e \int_0^g E_z(z) e^{j\omega t} dz$$

with $\omega t = \omega \frac{z}{v} - \psi_p$

where ψ_p is the phase of the particle, relative to the RF, when entering the gap.

Hence

$$\begin{aligned} \Delta E &= e \Re e \left[e^{-j\psi_p} \int_0^g E_z(z) e^{j\omega \frac{z}{v}} dz \right] \\ &= e \Re e \left[e^{-j\psi_p} e^{j\psi_i} \int_0^g E_z(z) e^{j\omega \frac{z}{v}} dz \right] \end{aligned}$$

By introducing $\phi = \psi_p - \psi_i$

one finally gets :

$$\Delta E = e \left| \int_0^g E_z(z) e^{j\omega \frac{z}{v}} dz \right| \cos \phi$$

which has a maximum value for $\phi = 0$.

Now ϕ appears as the phase of the particle referred to the particular phase which would yield the maximum energy.

II.2 - SHUNT IMPEDANCE

The shunt impedance R_s for an RF cavity operating in the standing wave mode is a figure of merit which relates the accelerating voltage V to the power P_d dissipated in the cavity walls :

$$P_d = \frac{V^2}{R_s}$$

The shunt impedance is very often defined as a quantity per unit length. So, a more general definition which takes also care of travelling-wave structures is :

$$\frac{dP}{dz} = - \frac{E_z^2}{r} \quad \text{with } r = \frac{R_s}{L}$$

where L is the cavity length, r the shunt impedance per unit length, E_z the amplitude of the accelerating field, and $\frac{dP}{dz}$ the fraction of the input power lost per unit length in the walls (another fraction will go into the beam). The sign in the right hand side means that the power flowing along a travelling-wave structure decreases due to the losses.

In the case of standing-wave cavities an uncorrected shunt impedance Z is sometimes defined (computer codes for designing cavities) where V is the integral of the field envelope along the gap. Then, to take care of the transit time factor the true shunt impedance becomes

$$R_s = Z T^2$$

Shunt impedances up to 35 M Ω /m are reached in proton linacs operating at 200 MHz and relatively low energy, while shunt impedances up to 100 M Ω /m can be obtained at 3 GHz in electron linacs. For the latter a peak power of 50 MW (for instance supplied by a high power pulsed klystron) would give an accelerating gradient of 70 MV/m in a 1 meter long structure.

However, present electron linacs work in the range of 10 to 20 MV/m with less efficient structures and lower peak power from more conventional pulsed klystrons.

If a standing-wave structure, with shunt impedance R_s , is used in the travelling-wave mode then the shunt impedance is doubled. This comes from the fact that a standing wave can be considered as the superposition of two travelling waves of opposite direction, each wave leading to power losses in the walls.

It is desirable to have a shunt impedance per unit length r as high as possible. Let's

have a look to the dependance of r upon the operating frequency :

- The RF power loss per unit length is proportional to the product of the square of the wall current i_w and the wall resistance r_w per unit length :

$$\frac{dP}{dz} \propto i_w^2 r_w$$

- the axial electric field E_z is proportional to the wall current divided by the radius b of the cavity :

$$E_z \propto i_w/b$$

- the wall resistance r_w per unit length is equal to the resistivity ρ of the wall material divided by the area of the surface through which the current is flowing :

$$r_w = \rho/2\pi b \delta$$

where δ is the skin depth given by :

$$\delta = (2\rho/\omega\mu)^{1/2}$$

and μ is the permeability of the walls. Combining all these expressions and knowing that $b \propto 1/\omega$ yield to the result :

$$r \propto \sqrt{\omega}$$

which shows, from the viewpoint of RF power economy, that it is better to operate at higher frequencies. But there is however a limit in going to very high frequencies due to the fact that the aperture for the beam must be kept large enough.

II.3 - QUALITY FACTOR AND STORED ENERGY

The quality factor Q is defined by :

$$Q = \frac{\omega W_s}{P_d}$$

where W_s is the stored energy. Clearly Q remains the same if the structure is used either in the standing-wave mode or the travelling-wave mode. It is also common to use the stored energy per unit length of the structure $w_s = dW_s/dz$.

Then :

$$Q = - \frac{\omega w_s}{dP/dz}$$

Another quantity of interest is the ratio r/Q :

$$\frac{r}{Q} = \frac{E_z^2}{\omega w_s}$$

quantity which only depends on the cavity geometry at a given frequency, and which can be measured directly by a perturbation method. The other quantities depend on other factors like the wall material, the quality of brazing ect... Q varies like $\omega^{-1/2}$, hence r/Q varies like ω .

Exercise : Fields, quality factor Q and ratio r/Q for a pill-box cavity

Note that pill-box cavities are very representative of single-cell accelerating structures in most cases.

The field components for TM_{npq} modes in cylindrical cavities are given by :

$$E_z = k_2^2 \cos k_1 z J_n(k_2 r) \cos n\theta$$

$$E_r = -k_1 k_2 \sin k_1 z J_n'(k_2 r) \cos n\theta$$

$$E_\theta = \frac{nk_1}{r} \sin k_1 z J_n(k_2 r) \sin n\theta$$

$$H_z = 0$$

$$H_r = -\frac{j}{Z_0} \frac{nk}{r} J_n(k_2 r) \sin n\theta$$

$$H_\theta = -\frac{j}{Z_0} k k_2 J_n'(k_2 r) \cos n\theta$$

$$Z_0 = (\mu_0/\epsilon_0)^{1/2}$$

satisfying the boundary conditions :

$$E_r = E_\theta = 0 \quad \text{for} \quad z = 0 \text{ and } z = \ell$$

$$E_z = E_\theta = 0 \quad \text{for} \quad r = a$$

with

$$k_1 = \frac{q\pi}{\ell} \quad J_n(k_2 a) = 0 \quad k_2 = \frac{v_{np}}{a}$$

$$k^2 = \frac{4\pi^2}{\lambda^2} = \left(\frac{q\pi}{\ell}\right)^2 + \left(\frac{v_{np}}{a}\right)^2$$

The most simple mode in a cylindrical cavity is the mode TM_{010} . This is the fundamental mode which however requires $\frac{\ell}{a} < 2$. This mode has only two components (Fig. 15):

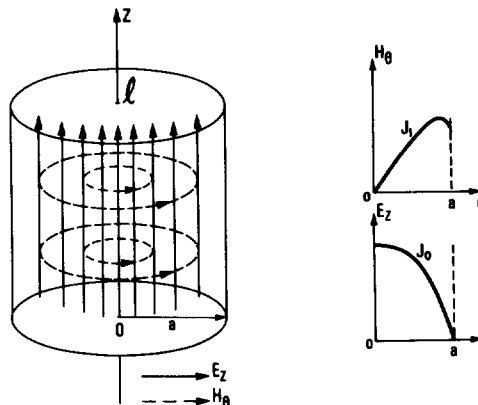

Fig. 15 - TM_{010} mode in a pill-box cavity

$$E_z = J_0(kr)$$

$$H_\theta = -\frac{j}{z_0} J_1(kr)$$

$$(J_0' = -J_1)$$

The resonant frequency is given by $v_{np} = 2.4$ and $\lambda = \frac{2\pi a}{2.4} = 2.62$ a

For $\lambda = 10$ cm one gets $a = 3.8$ cm

In a resonant circuit, Q is expressed as follows :

$$Q = 2\pi f \frac{\frac{1}{2} LI^2}{\frac{1}{2} RI^2} = \frac{L\omega_0}{R} \quad \text{with} \quad \omega_0 = \frac{1}{\sqrt{LC}}$$

So, one can write for the definition of Q

$$Q = 2\pi \frac{\text{Stored Energy}}{\text{Energy lost during one period}}$$

which can now be extended to a resonant cavity.

The stored energy in the cavity volume is given by :

$$W_s = \frac{\mu}{2} \int_V |H|^2 dV = \frac{\epsilon}{2} \int_V |E|^2 dV$$

For the power losses in the walls, one notices that the magnetic field induces in the wall a current $\vec{i} = \vec{n} \times \vec{H}$ or $i = H$. Then the losses are given by :

$$P_d = \frac{1}{2} \int_S R_w H^2 dS$$

where R_w is the surface resistance for a layer of unit area and width δ (skin depth) :

$$R_w = \frac{1}{\sigma\delta} \quad \text{with} \quad \delta = \frac{1}{\sqrt{\pi\mu\sigma f}}$$

and where σ is the material conductivity and f the RF frequency. So :

$$dP_d = \frac{\pi\mu\delta}{2} |H|^2 f dS$$

The energy lost during one period is :

$$dW_d = \frac{1}{f} dP_d = \frac{\pi\mu\delta}{2} |H|^2 dS$$

and for the total wall surface :

$$W_d = \frac{\pi\mu\delta}{2} \int_S |H|^2 dS$$

Hence :

$$Q = \frac{2 \int_V |H|^2 dV}{\delta \int_S |H|^2 dS} = \frac{2}{\delta} \frac{KV}{S}$$

where K is the form factor of the given geometry.

Considering again the TM_{010} mode in a pill-box cavity one gets :

$$\int_V H_\theta^2 dv = \ell \int_0^a J_1^2(k_2 r) 2\pi r dr$$

$$\int_S H_\theta^2 dS = 2 \int_0^a J_1^2(k_2 r) 2\pi r dr + 2\pi a \ell J_1^2(k_2 a)$$

so

$$\frac{1}{Q} = \frac{\delta}{\ell} \frac{\int_0^a J_1^2(k_2 r) r dr + \frac{a\ell}{2} J_1^2(k_2 a)}{\int_0^a J_1^2(k_2 r) r dr}$$

From the relation :

$$\int_0^a J_1^2(k_2 r) r dr = \frac{a^2}{2} J_1^2(k_2 a)$$

one gets

$$Q = \frac{\ell}{\delta} \frac{a}{a + \ell} \propto \omega^{-1/2}$$

and for example :

$$\delta = 10^{-6} \text{ m} \quad a = 3.8 \cdot 10^{-2} \text{ m} \quad \ell = 5 \cdot 10^{-2} \text{ m}$$

gives $Q = 21590$

In addition one can also get the quantity $\frac{r}{Q}$ (r being the uncorrected shunt impedance)

$$\frac{r}{Q} = \frac{V^2}{\omega W_s \ell} = 2.58 \mu\text{f} \propto \omega$$

hence

$$r \propto \omega^{1/2}$$

II.4 - FILLING TIME

From the definition of Q one has for a resonant cavity :

$$P_d = \frac{\omega}{Q} W_s$$

If the cavity has been initially filled, the rate at which the stored energy decreases is related to the power dissipated in the walls :

$$\frac{dW_s}{dt} = - \frac{\omega}{Q} W_s$$

Hence the time it takes for the electric field to decay to 1/e of its initial value is :

$$t_f = \frac{2Q}{\omega}$$

which is the filling time of the cavity. In the case of a travelling-wave structure the definition of the filling time is different

$$t_f = \frac{L}{v_e}$$

where L is the length of the structure and v_e the velocity at which the energy propagates. In a travelling-wave structure the stored energy exists but never adds up because it is dissipated in a terminating load and does not reflect.

II.5 - PHASE VELOCITY AND GROUP VELOCITY

These two concepts are of high importance in the case of particle acceleration by means of travelling guided waves. As mentioned before such methods are mostly used for particles which velocity is either close or equal to the light velocity c.

Let's first assume a cylindrical waveguide, and search for the simplest TM (or E) mode which can propagate. Such a mode, with an axial electric field component E_z , is the TM_{01} mode which also has two transverse components E_r and H_θ :

$$E_z = E_0 J_0(k_c r) e^{-j\beta z}$$

$$E_r = j \frac{\beta}{k_c} E_0 J_1(k_c r) e^{-j\beta z}$$

$$H_\theta = \frac{1}{Z_0} j \frac{k_0}{k_c} E_0 J_1(k_c r) e^{-j\beta z}$$

$$Z_0 = \sqrt{\frac{\mu}{\epsilon}} = 377 \text{ ohms}$$

where β is the propagation factor of the wave travelling in the +z direction, satisfying the relation:

$$\beta^2 = k_0^2 - k_c^2$$

with:

$$k_0 = \frac{2\pi}{\lambda_0} = \frac{\omega}{c}$$

$$J_0(k_c a) = 0 \quad k_c a = 2.4$$

$$k_c = \frac{2\pi}{\lambda_c} = \frac{\omega_c}{c}$$

and where a is the inner radius of the cylindrical waveguide, ω the excitation frequency, ω_c the cut off frequency.

The wavelength λ_g of the propagating wave is such that:

$$\beta = \frac{2\pi}{\lambda_g} = \frac{\omega}{v_p}$$

where v_p is the velocity of the wave or phase velocity. In order for the wave to propagate λ_g must be real and positive which means :

$$\lambda_o < \lambda_c$$

or

$$v_p > c$$

In order to lower the phase velocity the waveguide is loaded by disks, equally spaced if the particle is ultra-relativistic ($v \sim c$). The disks act like capacitive loads and reduce the speed of propagation as in loaded transmission lines.

It is usual to draw the Brillouin diagram for the type of propagating wave under consideration. This diagram relates the frequency to the propagation factor (Fig. 16).

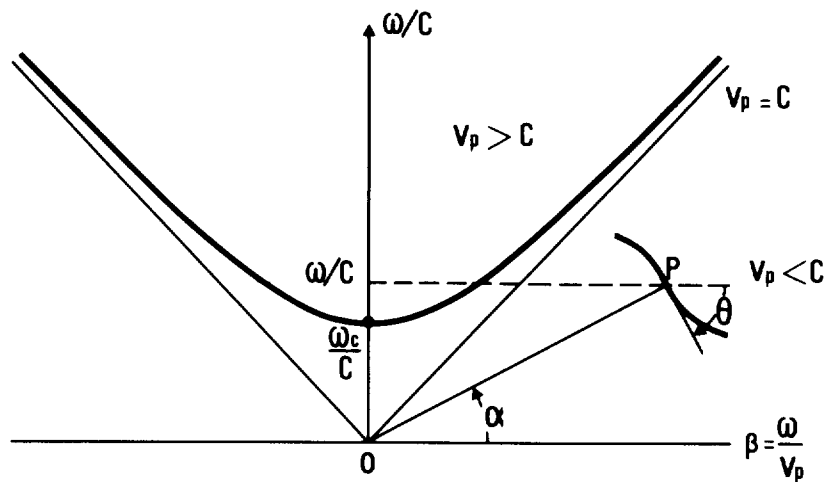

Fig. 16 - Brillouin diagram

The straight line $v_p = c$ separates the two domains corresponding respectively to slow and fast waves. For the latter, as obtained in a normal guide, the relation

$$\frac{\omega^2}{v_p^2} = \frac{\omega^2}{c^2} - \frac{\omega_c^2}{c^2}$$

gives an hyperbola for a given ω_c .

For a slow wave it will exit an operating point P in the diagram and the corresponding phase velocity is given by $\text{tg} \alpha = \frac{v_p}{c}$. If ω varies, P moves on a certain curve ; the slope of this curve at point P is :

$$\text{tg} \theta = \frac{d(\omega/c)}{d(\omega/v_p)} = \frac{1}{c} \frac{d\omega}{d\beta} = \frac{1}{c} v_g$$

where $v_g = \left(\frac{d\beta}{d\omega}\right)^{-1}$ is called the group velocity and happens to be equal to the velocity of the energy flow in the waveguide :

$$v_g = v_e$$

Exercise : Calculation of the energy flow velocity

The average power which flows through a transverse cross-section of a waveguide is given by the integral of the Poynting vector :

$$P = \frac{1}{2} \operatorname{Re} \int_S (\mathbf{E}_T \times \mathbf{H}_T) \cdot d\mathbf{s}$$

where only the transverse components of the field have to be considered. For a TM mode the relation between \mathbf{E}_T and \mathbf{H}_T is :

$$\frac{\mathbf{E}_T}{\mathbf{H}_T} = Z_0 \frac{\lambda_0}{\lambda_g}$$

$$P = \frac{1}{2} \int_S \frac{1}{Z_0} \frac{k_0}{\beta} |\mathbf{E}_T|^2 dS$$

The energy stored in the magnetic field (purely transverse component) per unit length is :

$$w_{sm} = \frac{\mu}{4} \int_S |\mathbf{H}_T|^2 dS = \frac{\mu}{4} \frac{1}{Z_0^2} \frac{k_0^2}{\beta^2} \int_S |\mathbf{E}_T|^2 dS$$

The energy stored in the electric field per unit length is equal to that of the magnetic field. Hence the total stored energy per unit length is :

$$w_s = w_{se} + w_{sm} = 2 w_{sm}$$

The velocity of the energy flow is then given by :

$$v_e = \frac{P}{w_s} = \frac{\frac{1}{2Z_0} \frac{k_0}{\beta}}{\frac{\mu}{4} \frac{1}{Z_0^2} \frac{k_0^2}{\beta^2}} = \frac{1}{\mu} \frac{1}{Z_0} \frac{\beta}{k_0} = \frac{1}{\mu} \sqrt{\frac{\mu}{\epsilon}} \frac{\beta}{k_0}$$

$$v_e = \frac{\beta}{k_0} c$$

Since :

$$v_g = \left(\frac{d\beta}{d\omega} \right)^{-1} = c \frac{dk_0}{d\beta} = \left[\frac{d(\omega^2/c^2 - k_0^2)^{1/2}}{d\omega} \right]^{-1}$$

one gets :

$$v_g = \frac{\beta c^2}{\omega} = \frac{\beta c}{k_0} = v_e$$

II.6 - SPACE HARMONICS IN LOADED WAVEGUIDES

In an infinite periodic structure (Fig. 17) the wave equation must satisfy the periodic boundary condition imposed by the disks. This is obtained by choosing a solution of the form :

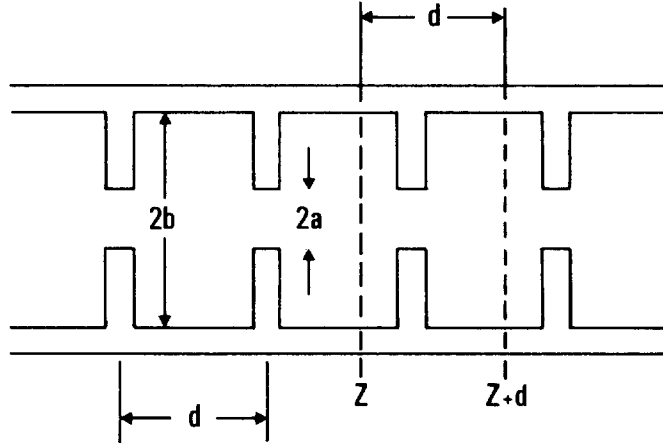

Fig. 17 - Periodic loaded structure

$$E(x, \theta, z) = e^{-\gamma z} E_1(x, \theta, z)$$

$$H(x, \theta, z) = e^{-\gamma z} H_1(x, \theta, z)$$

where E_1 and H_1 are periodic functions : $E_1(x, \theta, z+d) = E_1(x, \theta, z)$. Considering two similar terminal planes in two consecutive cells, that means the fields will repeat except the multiplication factor $e^{-\gamma d}$ which can be related to the propagation time from one cell to the next.

The possibility of expressing the field in the above form is often referred to as the FLOQUET's theorem (the original FLOQUET's theorem dealt with differential equations with periodic coefficients and the case of periodic boundary conditions is an extension of that work).

Any periodic function such as $E_1(x, \theta, z)$ can be expanded into an infinite FOURIER series ; thus

$$E_1(x, \theta, z) = \sum_{n=-\infty}^{+\infty} E_{1n}(x, \theta) e^{-j 2 n \pi z/d}$$

Considering a lossless structure, the propagation requires γ to be imaginary :

$$\gamma = j\beta_0$$

Hence the field becomes :

$$E(r, \theta, z) = \sum_{n=-\infty}^{+\infty} E_{1n}(r, \theta) e^{-j\beta_n z}$$

with

$$\beta_n = \beta_0 + 2n\pi/d$$

β_0 is the propagation factor of the fundamental space harmonic.

In addition the field has to satisfy the usual transverse boundary conditions of cylindrical waveguides. Thus, if one concentrates only on the lowest TM type mode the field components in a periodic disk loaded structure are :

$$E_z = \sum_n E_{on} J_0(k_{c,n} r) e^{-j\beta_n z}$$

$$E_r = j \sum_n \frac{\beta_n}{k_{c,n}} E_{on} J_1(k_{c,n} r) e^{-j\beta_n z}$$

$$H_\theta = \frac{j}{Z_0} \sum_n \frac{k_0}{k_{c,n}} E_{on} J_1(k_{c,n} r) e^{-j\beta_n z}$$

with the more general relation

$$\beta_n^2 = k_0^2 - k_{c,n}^2$$

Notice that all the space harmonics exist at a given frequency ω . Once β_0 is known all β_n 's are known. Moreover each space harmonic has a different phase velocity given by :

$$v_{pn} = \frac{\omega}{\beta_0 + \frac{2\pi n}{d}}$$

The group velocity of the n^{th} harmonic is :

$$v_{gn} = \frac{d\omega}{d\beta_n} = \left(\frac{d\beta_n}{d\omega}\right)^{-1} = \left(\frac{d\beta}{d\omega}\right)^{-1} = v_g$$

It is the same for all harmonics.

The brillouin diagram for a loaded structure (or slow wave structure) is represented on Fig. 18. At a given frequency there is an infinite number of points P corresponding to the

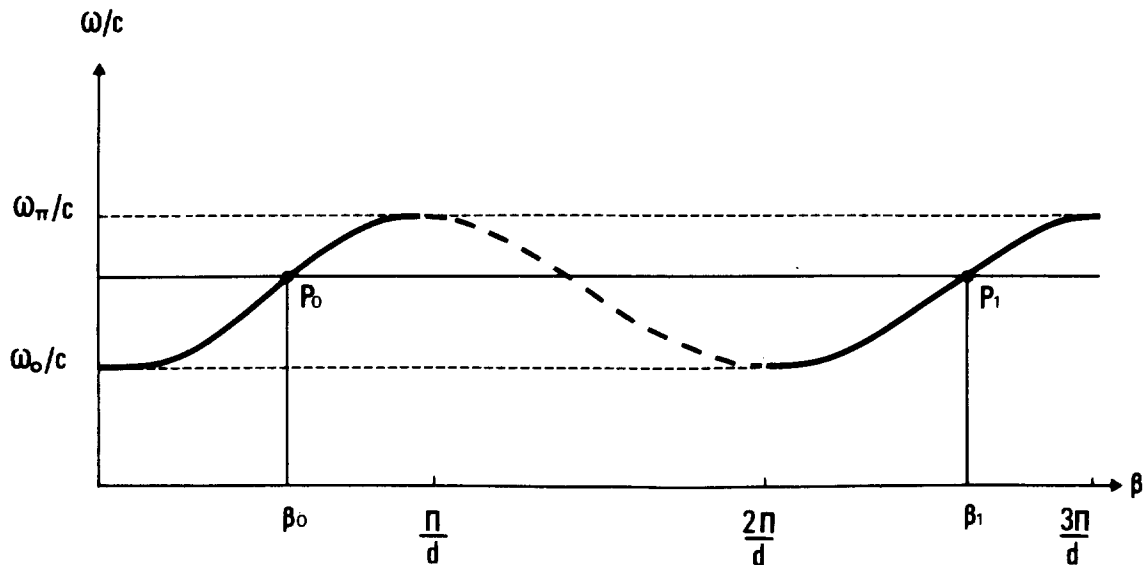

Fig. 18 - Brillouin diagram for a slow wave structure

propagation factors β_n . If the frequency changes, the points move on curves which have all the same slope, corresponding to the group velocity. Hence one gets pieces of curve which can all be deduced by a simple translation of $\frac{2\pi}{d}$. Since these curves must join, obviously they must have zero slopes somewhere leading to the shape of Fig. 18. It happens that the first part of the curve has a zero slope, hence zero group velocity, at $\beta d = 0$ and π which give the lower ω_0/c and upper ω_π/c frequencies of a pass band which remains true for the higher space harmonics. The condition of propagation hence corresponds to :

$$0 \leq \cos \beta d \leq 1$$

At $\beta d = \pi$ the phases in two successive cells are opposite (π mode) and one gets a standing wave pattern in the combination of all the space harmonics.

The calculation of the real fields in loaded structures which would take careful account of all boundary conditions is tedious. Generally a reasonably accurate description of the dispersion curve, relating β to k_0 , is obtained by an equivalent transmission line analysis or a coupled resonators chain analysis.

In order to accelerate electrons which already have the light velocity c the operating point in the Brillouin diagram must correspond to the intersection of the k_0, β curve with the 45° line (Fig. 19).

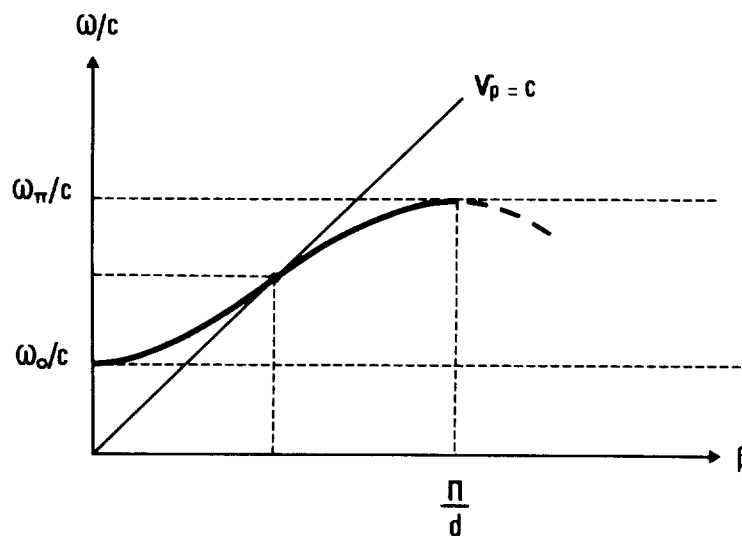

Fig. 19 - Operating point for $v_p = c$

In a travelling wave structure the π mode is avoided according to the previous remarks. Either $\pi/2$ or $2\pi/3$ modes are used. For the former a phase shift of 2π is obtained over 4 cells while for the latter it needs 3 cells.

For an acceleration to take place one chooses the fundamental space harmonic such that :

$$\beta_0 = \frac{\omega}{c}$$

$$\beta_0 d = \frac{\pi}{2} \text{ or } \frac{2\pi}{3}$$

The fundamental is the only one to give a net accelerating field since the higher space harmonics have no effect on the average. Hence, most of the particle dynamics in a travelling wave structure can be treated only using the fundamental space harmonic which can be calculated, for any structure having cylindrical symmetry, with the help of powerful computer codes like LALA or SUPERFISH. The radial dimension of the structure is determined to fit the operating frequency ω .

III. ENERGY GAIN IN LINEAR ACCELERATING STRUCTURES

III.1 - STANDING-WAVE STRUCTURES

The energy gain in a standing-wave structure is straightforward when the shunt impedance corrected by the transit time factor is known. However, when the power source is matched to the resonant structure through a coupling loop, such that no power is reflected toward the source, then the loaded Q value becomes :

$$Q_L = \frac{Q}{1 + \beta}$$

where the coupling coefficient β is unity when the power given to the beam is negligible. The corresponding filling time now becomes :

$$t_f = \frac{2Q_L}{\omega} = \frac{2Q}{\omega(1+\beta)}$$

For long power pulses there is no peculiar effect, but for short power pulses which length is of the order of the filling time (acceleration of short beam pulses) there will be a transient effect during the filling of the cavity where reflected power can not be avoided. Hence the minimum power required to attain a certain accelerating voltage will depend on the coupling coefficient and not only on the shunt impedance.

III.2 - TRAVELLING-WAVE STRUCTURES

For travelling-wave structures the energy gain will depend on the RF characteristics of the cells in a more complicated way. It is usual to distinguish between constant impedance structures and constant gradient structures.

III.2.1 - Constant impedance structure

In a constant impedance structure, for instance of the disk loaded type, all the cells are identical. Hence the group velocity v_g , which depends on the geometrical parameters of the cells, remains constant all along the structure. If L is the total length of the structure the filling time is :

$$t_f = \frac{L}{v_g}$$

For a disk loaded structure as the one drawn on Fig. 7, operating in the $2\pi/3$ mode at 3 GHz, the group velocity, which is a strong function of the iris diameter $2a$ is approxima-

tely given by :

$$v_g/c = \frac{(2a)^{3.23}}{891}$$

where 2a is expressed in cm. For instance, $v_g = .01 c$ for $2a = 1.97$ cm.

As the waves propagate in such a structure, part of the input power is dissipated into the walls and the remaining power will lead to a smaller accelerating field. Hence the accelerating gradient decreases continuously along the structure. It was shown in the previous section that :

$$Q = - \frac{\omega w_s}{dP/dz}$$

$$\frac{r}{Q} = \frac{E^2}{\omega w_s}$$

$$w_s = P/v_g$$

So one can write :

$$\frac{dP}{dz} = - \frac{\omega P}{v_g Q}$$

leading to the exponential behaviour :

$$P = P_0 e^{- (\omega/v_g Q) z}$$

$$E = E_0 e^{- (\omega/2 v_g Q) z}$$

At the input of the structure the accelerating field E_0 is related to the input power P_0 :

$$E_0^2 = P_0 \frac{\omega}{v_g} \frac{r}{Q}$$

Integrating the field along the structure leads to the energy gain :

$$V_{total} = \int_0^L E(z) dz = 2 E_0 v_g \frac{Q}{\omega} \left[1 - e^{- (\omega/2 v_g Q) L} \right]$$

It is common to use the attenuation factor τ of the structure as follows :

$$e^{-2\tau} = P(z=L)/P(z=0)$$

Then

$$\tau = \frac{1}{2} \frac{\omega L}{Q v_g} = \frac{1}{2} \frac{\omega}{Q} t_f$$

and the expression for the energy gain becomes :

$$V_{total} = (P_0 r L)^{1/2} [(2\tau)^{1/2} (1 - e^{-\tau})/\tau]$$

exercise :

Consider a disk loaded structure, 1 meter long, operating at 3 GHz in the $2\pi/3$ mode and assume an iris diameter of 1.97 cm which gives $v_g/c = .01$. For such a structure made of copper the shunt impedance per meter is roughly :

$$r_{[\text{M}\Omega/\text{m}]} = 86 - 3.6 (2a)_{[\text{cm}]}^2 = 72 \text{ M}\Omega/\text{m}$$

while Q is practically independant of $(2a)$ and equal to 15000.

For this example the performances of the structure are :

$$t_f = 0.33 \mu\text{s}$$

$$\tau = 0.21 \text{ neper}$$

$$V_{[\text{MeV}]} = 5 \sqrt{P_{\text{O}}[\text{MW}]}$$

III.2.2 - Constant gradient structure

In order to compensate for the variation of the accelerating field along the structure, due to power dissipation, it is possible to lower the group velocity from cell to cell, by changing the geometry for the same operating frequency. In fact this is obtained by reducing the iris aperture and by reducing the diameter of the cell at the same time. Such a scheme will make a better use of the available power.

In a perfect constant gradient structure $E = \text{cte}$, so one must have :

$$\frac{dP}{dz} = \text{cte}$$

assuming the shunt impedance is not too much affected by the change in the iris aperture.

Then one can write :

$$P = P_{\text{O}} - (P_{\text{O}} - P_{\text{L}}) \frac{z}{L}$$

where L is the length of the structure, P_{O} the input power and P_{L} the output power.

By analogy with the constant impedance case it is usual to define the attenuation factor τ such that :

$$P_{\text{L}}/P_{\text{O}} = e^{-2\tau}$$

Then one has :

$$P = P_{\text{O}} [1 - (1 - e^{-2\tau}) \frac{z}{L}]$$

$$\frac{dP}{dz} = -P_{\text{O}} (1 - e^{-2\tau})/L = -\frac{\omega P}{v_g Q}$$

leading to a linear variation for the group velocity :

$$v_g(z) = \frac{\omega L}{Q} \frac{[1 - (1 - e^{-2\tau}) \frac{z}{L}]}{(1 - e^{-2\tau})}$$

The values of the group velocity at both extremities are :

$$v_g(0) = \frac{\omega L}{Q} \frac{1}{1 - e^{-2\tau}}$$

$$v_g(L) = \frac{\omega L}{Q} \frac{e^{-2\tau}}{1 - e^{-2\tau}}$$

The attenuation factor is well defined when the output group velocity is known.

$$e^{2\tau} = 1 + \frac{\omega L}{Q v_g(L)}$$

In practice the iris diameter at the end of the structure is made as small as possible compatible with the dimensions of the accelerated beam. Setting the output group velocity and the length of the structure give the input group velocity.

The filling time in the present case is :

$$t_f = \int_0^L \frac{dz}{v_g(z)} = \frac{Q}{\omega} \text{Ln} \left[1 + \frac{\omega L}{Q v_g(L)} \right]$$

$$t_f = 2\tau \frac{Q}{\omega}$$

Integrating the accelerating field gives the energy gain :

$$V_{\text{total}} = \left[P_o r L (1 - e^{-2\tau}) \right]^{1/2}$$

with :

$$E = \left[\frac{P_o r}{L} (1 - e^{-2\tau}) \right]^{1/2}$$

Exercise :

Let's take the previous set of parameters and keep the shunt impedance constant.

One gets :

$$v_g(L)/c = .01$$

$$\tau = .175 \text{ neper}$$

$$t_f = .28 \mu\text{s}$$

$$v_g(0)/c = .014$$

$$V_{[\text{MeV}]} = 4.6 \sqrt{P_o[\text{MW}]}$$

The constant gradient case appears to be slightly less efficient. However in the constant impedance case the maximum field which takes place at the input is higher for equal

energy gains. Since there is some worry about field breakdown on the walls, the constant gradient structure finally appears more interesting although it is more difficult to build. An alternative is to build quasi-constant gradient structures made of constant impedance landings, with transition cells between the landings. In that case the number of different cells is reduced.

For travelling-wave linacs the length of the power pulse must be at least equal to the filling time in order to accelerate very short bunches. The particles travel fast through the structure as compared to the group velocity so they must enter when the structure is completely filled. For longer beam pulses the power pulse must follow in length.

Pulsed klystrons are available at the level of 50 MW with a pulse length $\leq 5 \mu\text{s}$. For short bunches ($\leq 10 \text{ ns}$) compression schemes are used which give shorter power pulses ($\leq 1 \mu\text{s}$), compatible with the structure filling time, with a higher peak power which can be as much as 4 times the direct klystron peak power. This is either used to double the energy of existing linacs (for instance SLAC at Stanford) or to reduce the total number of power sources for a given nominal energy (for instance the LEP Injector Linac).

IV. PARTICLE DYNAMICS IN LINEAR ACCELERATORS

Up to now a synchronism condition has been defined as a necessary condition for the particles to be accelerated in a linear structure. However this simple approach to the problem is not sufficient as it only describes the behaviour of selected particles which enter the accelerator at the right time with the right velocity.

In fact a bunch of particles, as it is produced by the gun, has a spread in velocities as well as a finite transverse dimension (beam emittance). Depending on their initial conditions the particles will undergo different stories during the acceleration. It is usual to differentiate the transverse motion of the particles from their longitudinal motion.

IV.1 - LONGITUDINAL MOTION : PHASE STABILITY

If particles enter continuously in an accelerating structure obviously a fraction of these particles will see the axial field E_z at the wrong time (or wrong phase) due to the sinusoidal time variation. This already gives a feeling of the bunching phenomenon that will occur in the two types of accelerators (discrete acceleration through gaps or continuous acceleration with travelling waves).

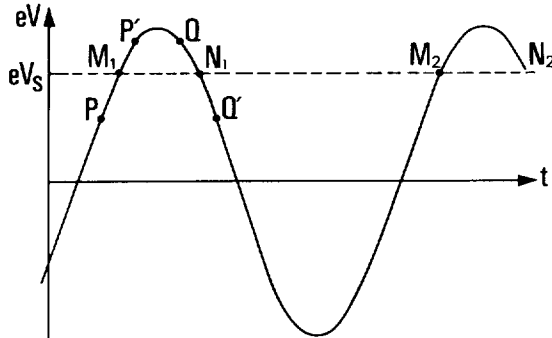

Fig. 20 - Particle phases relative to the RF field

Two particles which arrive at different times of the accelerating half period (see Fig. 20) can be either subject to equal energy gains (M_1, N_1) or different energy gains (P, P'). Considering for instance an Alvarez structure in which the synchronism condition is obtained

for a given energy gain eV_s , then particles M_1, N_1, M_2 ect... will always see the same phase of the accelerating field.

A particle P which arrives in a gap in advance as compared to M_1 will get less energy and its velocity will be smaller so that it will take more time to travel through the drift tube. In the next gap it will appear closer to particle M_1 . The reverse effect is true for particle P' which will get more energy and reduce its delay time as compared to M_1 . Points M_1, M_2 ect... are stable points for the acceleration since particles slightly away from them will experience forces that will reduce their deviation. On the contrary it can be seen that points N_1, N_2 ect... are unstable points in the sense that particles slightly away from these points will shift even more in the next gaps.

In order to study the longitudinal motion one uses variables which give relative position, and energy, as compared to the synchronous particle :

$$\Delta t = t - t_s$$

$$\varphi = \phi - \phi_s = \omega(t - t_s) = \omega \Delta t$$

$$w = W - W_s$$

where ϕ_s is the RF phase of the synchronous particle and W_s the energy of the same particle. The accelerating field can be simply described by :

$$E_z = E_0 \cos\left(\omega t - \frac{\omega z}{v_p}\right) = E_0 \cos \phi$$

When the phase velocity varies, $\omega \frac{z}{v_p}$ must be replaced by $\omega \int \frac{dz}{v_p}$ in the forthcoming expressions so that they will remain valid. The azimuthal position z is generally taken as the independant variable instead of t .

IV.1.1 - Non-relativistic case - Adiabatic damping

The rate of energy gain for the synchronous particle is given by :

$$\frac{dW_s}{dz} = \frac{d}{dz} \left(\frac{1}{2} m v_s^2 \right) = \frac{d}{dt} (m v_s) = e E_0 \cos \phi_s$$

where E_0 would take into account the transit time in the case of standing-wave drift-tube linacs.

For other particles the energy gain can be expressed in reduced variables :

$$\frac{dw}{dz} = e E_0 [\cos(\phi_s + \varphi) - \cos \phi_s]$$

In addition one has :

$$\frac{d\varphi}{dz} = \omega \left(\frac{dt}{dz} - \frac{dt_s}{dz} \right) = \omega \left(\frac{1}{v} - \frac{1}{v_s} \right)$$

which turns out to be :

$$\frac{d\varphi}{dz} = - \frac{\omega}{m v_s^3} w$$

having assumed that :

$$w = W - W_s = \frac{1}{2} m (v^2 - v_s^2) \approx m v_s (v - v_s)$$

Considering small deviations from the synchronous particle one gets the following set of first-order linear equations :

$$\frac{d\varphi}{dz} = - \frac{\omega}{m v_s^3} w$$

$$\frac{dw}{dz} = - e E_0 \sin \phi_s \varphi$$

which represent a phase harmonic oscillation :

$$\frac{d^2\varphi}{dz^2} + \Omega_s^2 \varphi = 0$$

with angular frequency relative to the independent variable z

$$\Omega_s^2 = - \frac{e E_0 \omega \sin \phi_s}{m v_s^3}$$

showing that $\sin \phi_s$ has to be negative for stable solutions. Notice that this is true since v_s is a constant parameter. But the approach is still valid if v_s varies slowly. The wavelength of the small amplitude phase oscillation is given by :

$$\lambda_s = 2\pi / \Omega_s$$

and increases rapidly along the accelerator.

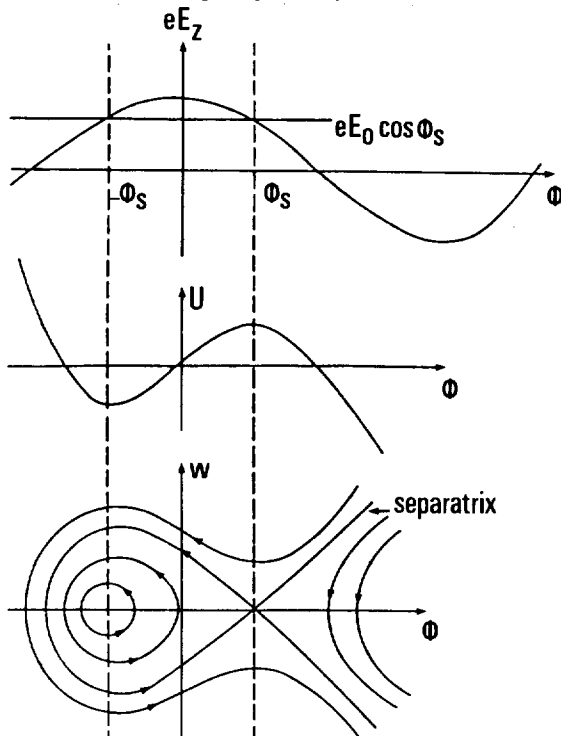

Fig. 21 - Phase stability graphs

Considering larger amplitudes one should write :

$$\frac{d^2\varphi}{dz^2} = - \frac{\omega}{m v_s^3} e E_0 [\cos (\phi_s + \varphi) - \cos \phi_s] = F$$

The restoring force F can be derived from an effective potential energy function U

$$U = - \int F d\varphi$$

which is drawn on Fig. 21. An analysis of the non-linear motion in the phase space w, φ shows that the oscillation is bounded at some energy w_{max} . The corresponding curve is called the separatrix.

The motion can be derived from a hamiltonian H satisfying the canonical equations:

$$\frac{dw}{dz} = - \frac{\partial H}{\partial \varphi} \quad \frac{d\varphi}{dz} = \frac{\partial H}{\partial w}$$

One gets :

$$H = -\frac{\omega}{2m v_s^3} w^2 - e E_0 (\sin(\varphi + \phi_s) - \varphi \cos \phi_s)$$

which, for small amplitudes, reduces to :

$$H \approx -\frac{\omega}{2m v_s^3} w^2 - \frac{1}{2} e E_0 \sin \phi_s \varphi^2$$

A particle with some initial conditions will perform an ellipse in the phase space. It's maximum energy w_{\max} is obtained when $\varphi = 0$ and correspondingly its maximum phase excursion φ_{\max} is obtained when $w = 0$. One has the relation :

$$\frac{w_{\max}}{\varphi_{\max}} = \left[\frac{e E_0 \sin \phi_s m v_s^3}{\omega} \right]^{1/2}$$

Liouville's theorem stipulates that for a conservative motion the area of the phase space ellipse is an invariant.

$$w_{\max} \varphi_{\max} = \text{cte}$$

This is normally true for a constant v_s , but can still be applied when considering adiabatic variation of this parameter (adiabatic theorem).

It follows from the previous relations that :

$$w_{\max} = \text{cte} \left(\frac{e E_0}{\omega} \sin \phi_s m v_s^3 \right)^{1/4}$$

$$\varphi_{\max} = \text{cte} \left(\frac{e E_0}{\omega} \sin \phi_s m v_s^3 \right)^{-1/4}$$

It appears that φ_{\max} will decrease during the acceleration and the bunch length will become shorter. On the contrary w_{\max} will increase, but the relative energy spread w/W_s , in which the user is interested, will decrease.

IV.1.2 - Relativistic case - Electron capture

In the case of relativistic particles :

$$\frac{dt}{dz} = \frac{1}{v} = \frac{1}{c} \gamma (\gamma^2 - 1)^{-1/2}$$

with

$$\gamma = (1 - \beta^2)^{-1/2} \quad \beta = \frac{v}{c}$$

Then it happens that the previous formulae remain valid just replacing v_s by $\gamma_s v_s$ and taking m as the rest mass.

The same phenomena occur for relativistic particles but the phase oscillation becomes very slow at high energies, so that in practice a particle can travel all along a linac in less than one oscillation period and some of the previous statements cannot have the same meaning any more. For instance if a short bunch of particles is captured in an electron linac and if all the particles have the light velocity they will keep that velocity and

always arrive at the same RF phase in the gaps. In that case the phase spread of the bunch will remain constant. Moreover if this phase spread is very small, for instance around the peak of the RF, all the particles will get the same energy and the absolute energy spread will also remain constant while the relative energy spread will go down like γ^{-1} .

It is now interesting to consider the case of electron linacs, where the structure has a phase velocity equal to c , and to look at what happens when particles enter the structure having still a velocity smaller than c , as for instance produced by electron guns.

So let's consider an accelerator with a phase velocity equal to c and an axial electric field E_z which has a sinusoidal time variation with constant amplitude E_0 along the trajectory. Then if E_z is the field seen by a particle one defines the phase angle ϕ between the wave and the particle by means of the relation :

$$E_z = E_0 \sin \phi$$

If v is the particle velocity, then

$$d\lambda = (c - v) dt$$

is the difference in path between the wave and the particle in the time dt . This path difference can also be expressed in term of the phase difference $d\phi$:

$$d\lambda = \frac{\lambda_g}{2\pi} d\phi$$

where λ_g is the wavelength of the propagation in the waveguide. From the above equations one gets :

$$\frac{d\phi}{dt} = \frac{2\pi c}{\lambda_g} (1 - \beta)$$

The equation of motion for the particle, in the relativistic case, is simply :

$$\frac{d}{dt} (mv) = m_0 c \frac{d}{dt} \left[\frac{\beta}{(1 - \beta^2)^{1/2}} \right] = e E_0 \sin \phi$$

and using a new variable α such that :

$$\beta = \cos \alpha$$

it becomes

$$\frac{d\alpha}{dt} = - \frac{e E_0}{m_0 c} \sin \phi \sin^2 \alpha$$

with

$$\frac{d\phi}{dt} = \frac{d\phi}{d\alpha} \frac{d\alpha}{dt}$$

Hence :

$$- \sin \phi d\phi = \frac{2\pi}{\lambda_g} \frac{m_0 c^2}{e E_0} \frac{1 - \cos \alpha}{\sin^2 \alpha} d\alpha$$

Integrating from time t_1 where $v = c$, to time t_0 where $\beta = \beta_0$, $\alpha = \alpha_0$ and $\phi = \phi_0$, one gets :

$$\cos \phi_1 - \cos \phi_0 = \frac{2\pi}{\lambda_g} \frac{m_0 c^2}{e E_0} \left[\operatorname{tg} \frac{\alpha_1}{2} - \operatorname{tg} \frac{\alpha_0}{2} \right]$$

Knowing that :

$$\operatorname{tg} \frac{\alpha}{2} = \frac{(1 - \cos \alpha)^{1/2}}{(1 + \cos \alpha)^{1/2}} = \frac{(1 - \beta)^{1/2}}{(1 + \beta)^{1/2}}$$

one gets :

$$\cos \phi_0 - \cos \phi_1 = \frac{2\pi}{\lambda_g} \frac{m_0 c^2}{e E_0} \left(\frac{1 - \beta_0}{1 + \beta_0} \right)^{1/2}$$

Since the left hand side cannot be greater than 2 one must have :

$$E_0 \geq \frac{\pi m_0 c^2}{\lambda_g e} \left(\frac{1 - \beta_0}{1 + \beta_0} \right)^{1/2}$$

This "capture condition" must be satisfied in order to capture the electrons injected at a velocity less than the phase velocity. For example, for $\lambda_g = 10$ cm and an injection energy of 150 keV the condition gives $E_0 \geq 7.6$ MV/m which is technically possible.

In practice however, to improve the capture efficiency it is common to use a small bunching section in which the energy is brought to a few MeV with a variable phase velocity.

IV.2 - TRANSVERSE MOTION : DEFOCUSING

Looking at the electric field pattern in the gap between two drift tubes it is seen that there are radial components (Fig. 22), which are focussing at the gap entrance and defocussing at the end. In an electrostatic accelerator where the field is constant this gives

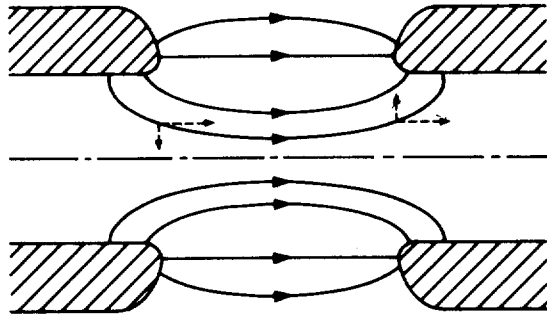

Fig. 22 - Field pattern in the gap of a drift tube accelerator

a global focussing effect since the particle having more energy at the end of the gap makes the defocussing effect smaller. In an RF accelerator the behaviour is different. From the phase stability requirement ($\phi_s < 0$) it appears that the field increases with time during the passage of the particle. Hence the defocussing force becomes larger than the focussing one resulting in a transverse instability as the particle may strike the drift tubes.

It is possible to show the effect mathematically using approximate transverse field expressions only valid for small transverse

deviations from the axis :

$$E_z = E_0 \sin\left(\omega t - \omega \int \frac{dz}{v_p}\right)$$

$$E_r = \frac{r \omega E_0}{2 v_p} \cos\left(\omega t - \omega \int \frac{dz}{v_p}\right)$$

$$B_\theta = \frac{r \omega E_0}{2 c^2} \cos\left(\omega t - \omega \int \frac{dz}{v_p}\right)$$

The transverse force acting on the particle is given by the Newton-Lorentz equation :

$$\frac{d}{dt} (m \dot{r}) = e E_r - e v B_\theta$$

$$= \frac{e r \omega E_0}{2 v_p} \left(1 - \frac{v v_p}{c^2}\right) \cos\left(\omega t - \omega \int \frac{dz}{v_p}\right)$$

Considering the synchronous particle for which $v = v_p$ and $\left(\omega t - \omega \int \frac{dz}{v_p}\right) = \phi_s + \frac{\pi}{2}$ one gets :

$$\frac{d}{dt} (m \dot{r}) = - \frac{e r \omega E_0}{2 v_p} (1 - \beta^2) \sin \phi_s$$

For ultra-relativistic particles ($v \approx c$) the transverse defocussing effect becomes negligible. In other words the transverse magnetic force compensate exactly the electric one. This is a well known behaviour in relativistic particle dynamics.

There are many other reasons for radial deflection of the particles than the normal transverse field components in a waveguide. For instance, in the input and output couplers of a travelling-wave structure there is an axial field asymmetry which induces transverse components and gives a transverse kick to the beam, even at $v = c$.

So finally in practice it is necessary to use external magnetic fields, such as given by solenoids or quadrupoles, to ensure a stable transverse motion within the aperture of the linac.

IV.3 - DYNAMICS IN A RADIO FREQUENCY QUADRUPOLE (RFQ)

Conventional proton (or heavy ion) linear structures, like the ALVAREZ structure, which use magnetic focussing, are only efficient in the range :

$$.04 < \beta = \frac{v}{c} < .5$$

For $\beta > .5$ it is better to use high- β linac structures.

For $\beta < .04$ successful activity in designing low- β structures is very recent (in the past, the solution consisted in applying a very high voltage on the gun to extract particles at energies that could match a drift tube structure) and the biggest success has been the

invention of the radio frequency quadrupole (RFQ) which combines three functions : electric focussing, bunching and acceleration.

The RFQ is a four vanes resonator with quadrupolar symmetry which provides a transverse electric gradient for transverse focussing (at low velocity, magnetic focussing is not efficient because of the v term which appears in the force equation). Modulated pole shapes

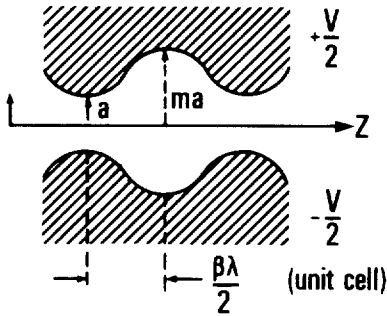

(Fig. 23) lead to a longitudinal variation of the transverse field gradient giving a longitudinal electric component for acceleration and bunching. In a drift tube structure the transit time factor is worse at low β ; in the RF quadrupole many cells are made (since β is small) in an overall practical length which permit a continuous acceleration and perfect adiabatic conditions to realize a very good bunching efficiency ($\sim 100\%$).

Fig. 23 - Modulated pole shapes in an RFQ

The spatially continuous fields also cure the space charge effects that could freely develop in the drift tubes of conventional structures.

The lowest order potential function, in cylindrical coordinates, which satisfies the quadrupole symmetry of an RFQ can be written as follows :

$$U = \frac{V}{2} \left[X \left(\frac{r}{a} \right)^2 \cos 2\psi + A I_0(kr) \cos kz \right] \sin(\omega t + \phi)$$

where V is the difference potential between adjacent pole tips, and :

$$k = 2\pi/\beta\lambda$$

From this, the following electric field components are obtained :

$$\left. \begin{aligned} E_r &= -\frac{XV}{a^2} r \cos 2\psi - \frac{kAV}{2} I_1(kr) \cos kz \\ E_\psi &= \frac{XV}{a^2} r \sin 2\psi \\ E_z &= \frac{kAV}{2} I_0(kr) \sin kz \end{aligned} \right\} \sin(\omega t + \phi)$$

with

$$A = (m^2 - 1) / (m^2 I_0(ka) + I_0(mka))$$

$$X = 1 - A I_0(ka)$$

The quantity VA is the potential difference that exists on the axis between the beginning and the end of a unit cell. Then the space average longitudinal field is :

$$E_0 = \frac{2AV}{\beta\lambda}$$

The energy gain for a particle with charge e and synchronous velocity βc traversing a unit cell is approximately :

$$\Delta W = e E_0 \ell T \cos \phi_s$$

$$\ell = \frac{\beta \lambda}{2}$$

and $T = \pi/4$ is the transit time factor for a longitudinal field with space variation $\sin k z$ and time variation $\sin \omega t$, knowing that when the particle travels one period $\beta \lambda = 2\pi/k$, the RF phase changes by 2π .

Applying the equations of phase oscillations to the RFQ gives the angular frequency for small oscillations :

$$\Omega_s^2 = \frac{e A V \omega^2 \sin \phi_s}{4 m_0 c^2 \beta^2}$$

the angular length of the separatrix, ϕ_m :

$$\text{tg } \phi_s = \frac{\sin \phi_m - \phi_m}{1 - \cos \phi_m}$$

and the spatial length of the separatrix :

$$z_m = \frac{\beta \lambda \phi_m}{2\pi}$$

Note that here ϕ_m is the phase difference between the 2 extreme elongations of the separatrix.

To avoid space charge phenomena it is interesting to keep the longitudinal density constant during bunching which means :

$$z_m = \text{cte}$$

condition which determines ϕ_s and A as functions of β .

The next interesting aspect of the RFQ is the transverse focussing during bunching and acceleration. The magnitude of the electric quadrupole strength is XV/a^2 which means that :

- for given a , m , β the strength is constant in a unit cell
- the same strength can be maintained in every unit by keeping XV/a^2 constant.

The equation for the transverse oscillation is :

$$\frac{d^2 x}{d\tau^2} = \left[\frac{XV}{m_0 c^2} \left(\frac{\lambda}{a} \right)^2 \cos 2\pi\tau - \frac{\pi^2}{2} \frac{AV}{m_0 c^2 \beta^2} \sin \phi \right] x$$

where τ is the reduced variable :

$$\tau = (\omega t + \phi)/2\pi$$

The previous equation is of the MATHIEU type :

$$\frac{d^2 x}{d\tau^2} + [A + B \cos 2\pi\tau]x = 0$$

which means that solutions can be stable for some combinations of A and B . It can be shown

that the oscillations will be stable if the following conditions are satisfied :

$$\frac{XV}{2\pi^2 m_0 c^2} \left(\frac{\lambda}{a}\right)^2 < 1 - \frac{VA}{2 m_0 c^2 \beta^2} \sin \phi$$

$$\frac{X^2V}{8\pi^3 m_0 c^2} \left(\frac{\lambda}{a}\right)^4 > - \frac{\pi A}{2\beta^2} \sin \phi$$

An analysis of these inequalities shows that in practice the transverse oscillations are stable with any values of the synchronous phase (up to -90°) just as in accelerators with static lenses.

In practice an RFQ can bring proton (or ion) energies from a few 10 keV to a few MeV over a very reasonable overall length (1 to 2 meters).

* * *

REFERENCES

- M. Stanley Livingston, John P. Blewett. Particle Accelerators
Mc Graw-Hill Book Company, INC, N.Y. 1962
- E. Persico, E. Ferrari, S.E. Segré. Principles of Particle Accelerators
W.A. Benjamin, INC, N.Y 1968
- P. Lapostolle, A. Septier (Editors). Linear Accelerators
North Holland Publishing Company, Amsterdam 1970
- P. Lapostolle. Introduction à l'étude des Accélérateurs Linéaires
CERN 66-20 (Juin 1966)
- P.B. Wilson. High Energy Electron Linacs : Applications to Storage Ring RF Systems and
Linear Colliders - SLAC PUB 2884
Also in AIP Conference Proceedings N°87, N.Y 1982
- G.A. Loew. Elementary Principles of Linear Accelerators
SLAC PUB 3221
Also in AIP Conference Proceedings N°105, N.Y 1983
- I.M. Kapchinskii and V.A. Teplyakov. Linear ion accelerator with spatially homogeneous strong
focussing.
Pribery i. Tekhnika Eksperimenta, 119, N°2 (March-April 1970)
- R.H. Stokes, K.R. Crandall, J.E. Stovall and D.A. Swenson. RF quadrupole beam dynamics.
IEE Transactions on Nuclear Science, Vol. NS-26, N°3 June 1979.
- R.E. Collin. Foundations for microwave Engineering International-Student Edition.
Mc Graw-Hill, INC. (1966).

