

**REMOTE ESTIMATION OF COLLIMATOR JAW DAMAGES WITH
SOUND MEASUREMENTS DURING BEAM IMPACTS**

D. Deboy, R. W. Assmann, O. Aberle, F. Carra, M. Cauchi, J. Lendaro, A. Masi, S. Redaelli
CERN, Geneva, Switzerland

Abstract

Irregular hits of high-intensity LHC beams on collimators can lead to severe damage of the collimator jaws. The identification of damaged collimator jaws by observation of beam measurements is challenging: online loss measurements at the moment of the impacts can be tricky and degradation of the overall performance from single collimator damage can be difficult to measure. Visual inspections are excluded because collimator jaws are enclosed in vacuum tanks without windows. However, the sound generated during the beam impact can be used to give an estimate of the damage level. In 2012, high-intensity beam comparable to a full nominal LHC bunch at 7 TeV was shot on a tertiary type LHC collimator at the HiRadMat test facility at CERN. The paper presents results from sound recordings of this experiment.

Presented at the International Particle Accelerator Conference (IPAC'13) –

May 12-17, 2012, Shanghai, China

Geneva, Switzerland, May 2013

REMOTE ESTIMATION OF COLLIMATOR JAW DAMAGES WITH SOUND MEASUREMENTS DURING BEAM IMPACTS*

D. Deboy, R. W. Assmann, O. Aberle, F. Carra, M. Cauchi, J. Lendaro, A. Masi, S. Redaelli
CERN, Geneva, Switzerland

Abstract

Irregular hits of high-intensity LHC beams on collimators can lead to severe damage of the collimator jaws. The identification of damaged collimator jaws by observation of beam measurements is challenging: online loss measurements at the moment of the impacts can be tricky and degradation of the overall performance from single collimator damage can be difficult to measure. Visual inspections are excluded because collimator jaws are enclosed in vacuum tanks without windows. However, the sound generated during the beam impact can be used to give an estimate of the damage level. In 2012, high-intensity beam comparable to a full nominal LHC bunch at 7 TeV was shot on a tertiary type LHC collimator at the HiRadMat test facility at CERN. The paper presents results from sound recordings of this experiment.

INTRODUCTION

The impact of high-intensity particle beam on LHC collimators has been extensively studied in recent years. Abnormal scenarios include rapid energy deposition which induces temperature increases and mechanical stresses in the solid materials of the collimator jaws [4]. These effects may lead to severe damage of the jaw surface. Several scenarios were simulated to determine expected damage levels from different beam intensities.

Preliminary results from proton beam tests with a horizontal, tertiary LHC collimator design (TCTH) at CERN's HiRadMat facility can be found in [3]. The experiment was designed to test unlikely fast failure scenarios of the LHC.

The dynamic responses of the jaw structure are known from numerical simulations [1]. The total deposited energy in the jaw material is calculated from FLUKA [6] simulations. The rapid heat-up of the jaw material increases with the deposited energy and may exceed the melting point of the material (~ 1343 C). The sudden temperature change yields a pressure wave which excites vibrations of the jaw with a dirac-like impulse δ .

The jaw is enclosed by an evacuated tank, therefore vibrations of the jaw surface cannot directly translate to sound. However, measurements with a microphone installed close to the collimator made explosive sounds audible in earlier experiments [7]. A linear, time-independent transfer path $C(z)$ of jaw vibrations to the collimator outer surfaces and the surrounding air is assumed. Vibrations generate sound that travels from the collimator surface to

the exposed microphone and is imposed by the impulse response of the room $T(z)$, c.f. Fig. 1.

The sound pressure measured at a microphone will increase with the excitation magnitude. The relation between total deposited energy and excitation magnitude is described by an equation of states, which cannot explicitly be given for cases where the melting point of the material is exceeded.

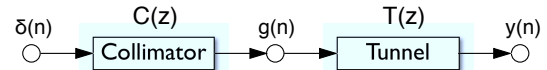

Figure 1: Transfer path of vibrations from the collimator jaw to the collimator tank and support, up to the microphone position in the tunnel area.

EXPERIMENTAL SETUP

The TCT type LHC collimator was placed on table B in the experimental area of the HiRadMat facility. A 440 GeV proton beam is extracted from the super proton synchrotron (SPS) and shot onto the collimator jaws, which were aligned with a beam based alignment prior to each of the presented tests. Details can be found in [3] in these proceedings. Table 1 shows the beam parameters of three beam hits onto the jaw material (INERMET 180). A single hit consists of several bunches with a bunch spacing of 50 ns. Each bunch has an intensity in the order of 10^{11} p. Test case 1 resembles the full impact of 1 nominal LHC bunch on a tertiary collimator.

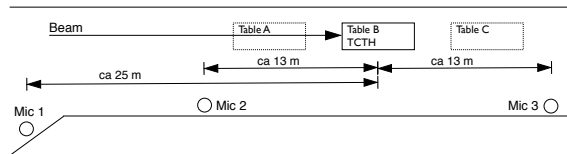

Figure 2: Sketch of the collimator and microphone locations in the experimental area of the HiRadMat facility.

Radiation effects in the electronics of microphones and accelerometers form large signal spikes during the beam impact. If installed too close, saturation may render measurements useless [5]. Non-prepolarized condenser pressure microphones are used to acquire sound data. To avoid saturation, the sensors were placed at a minimum distance of 13 m upstream and downstream of the TCTH collimator. An additional microphone was placed at 25 m distance upstream, c.f. Fig. 2.

* Supported by EuCARD, Work Package 8 - ColMat

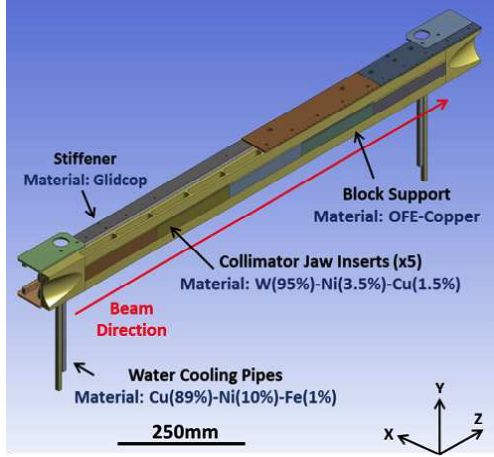

Figure 3: Jaw assembly of a TCTH collimator.

RESULTS FROM BEAM TESTS

The raw signals, Fig. 4, carry a strong signal spike from radiation impacting the sensor. Its onset is used as a trigger and marks the time of the beam impact, since the delay of the radiation impact is negligible. Mic 3 was saturated during test 1 and 3, Mic 2 was saturated during test 3.

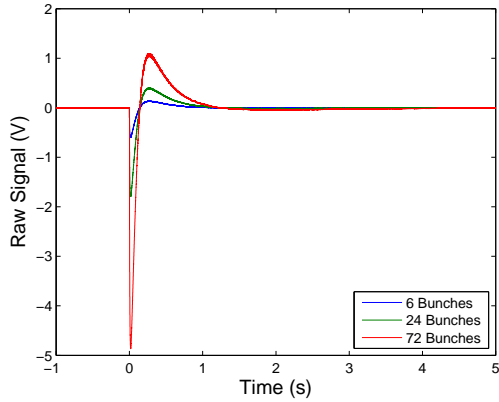

Figure 4: Raw Signal during Beam impacts for Microphone 1. Spikes occur from radiation effects in the sensor electronics. The real sound is superimposed to the refraction decay of the spike.

A high-pass butterworth filter of 3rd order with a cut off frequency of 100 Hz was chosen empirically to remove the slow decay that follows each spike with a constant refraction time. The resulting signal unveils the sound pressure progress induced by real sound, see Fig. 5.

Impact Location

The distance of the sound source to the microphone can be estimated with the time delay between a trigger signal and onset of the impact sound as shown in Fig. 6. A delay of $\Delta t_1 = 75$ ms and $\Delta t_2/3 = 44$ ms was determined. With the speed of sound in air at room temperature $c = 343$ m/s,

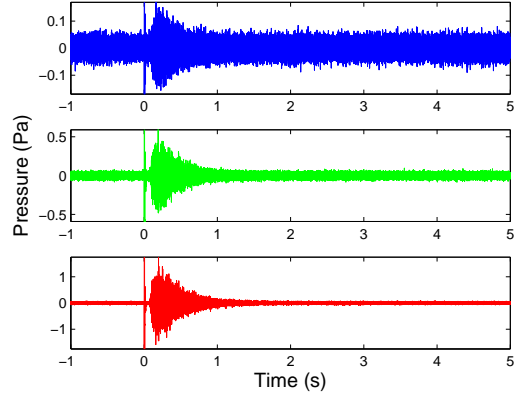

Figure 5: Filtered signals during Test 1 (top), 2 (middle) and 3 (bottom) for Microphone 1. A high-pass butterworth filter of 3rd order at 100 Hz removes the slow decay and reveals the real sound data. The spike can be used as event trigger of the beam impact.

Table 1: Beam and Sound Parameters of HiRadMat test.

Test	1	2	3
SPS extraction intensity [E12 p]	3.36	1.04	9.34
No of HRM bunches	24	6	72
Energy on Jaw [kJ]	87.89	27.72	249.87
Max L_p , Mic 1 [dB]	75.5	62.1	86.0
Max L_p , Mic 2 [dB]	75.5	62.1	NA
Max L_p , Mic 3 [dB]	NA	59.7	NA

it yields an estimated distance $d_1 = 25,7$ m for Microphone 1 and $d_2/3 = 15$ m for Microphone 2 and 3.

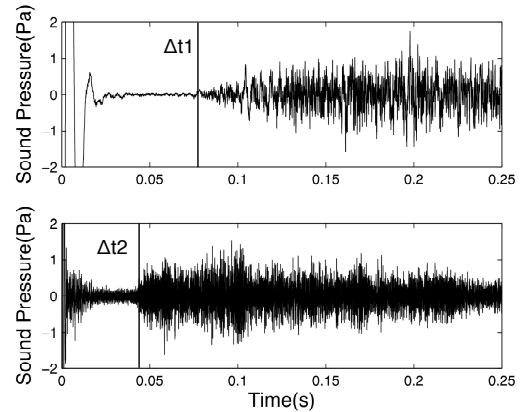

Figure 6: The time delays between beam and sound impact at microphone 1 (top) and 2 (bottom) are used to determine the distance between collimator and microphone.

Sound Pressure Level vs. Total Deposited Energy

The sound pressure level is derived from an RMS value of the sound pressure for each sample n ,

$$L_p(n) = 10 \log \left(\frac{1}{\tau f_s} \sum_n^{n+\tau f_s} \frac{p(n)^2}{p_0^2} - \frac{p_{noise}^2}{p_0^2} \right),$$

with a time constant of $\tau = 125$ ms (recommended for impulsive signals), sampling frequency $f_s = 200$ kHz, and a reference sound pressure $p_0 = 20 \mu Pa$. The RMS value of background noise p_{noise} is determined just before the impact with a time constant of 1 s.

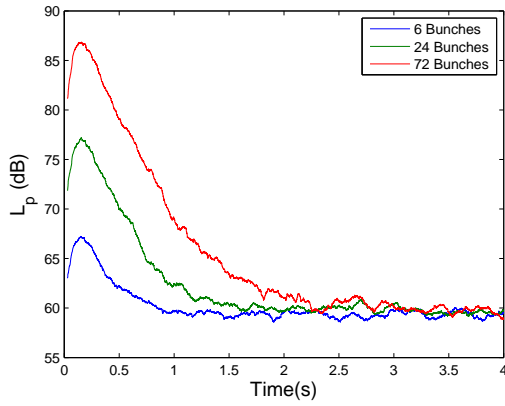

Figure 7: The sound pressure level L_p during the beam impact. The RMS values are calculated with a time constant of $\tau = 125$ ms.

In Fig. 8, the maximal sound pressure level L_p versus the total deposited energy is plotted for all three test cases. The linear interpolation can be used as a reference curve to determine the total deposited energy solely from the sound pressure level. In [3], the damage extend is shown for the three test cases. According to preliminary visual inspection, test 1 and 3 did evoke a damage of the jaw surface with a visible groove whilst test 2 did not produce visible damage of the surface. The threshold for damage of the surface integrity can therefore be found between test case 1 and 2.

SUMMARY

For the first time, the sound from beam hits on LHC collimators was recorded for cases that evoked severe damage to the collimator jaw. Results show that an increase in total deposited energy yields higher sound pressure levels. A “damage level meter” considers simulation data and visual inspection after the experiment.

The herein presented results show that an acoustic monitoring of collimator sections in the LHC is a promising tool for post-mortem analysis of beam induced damage in solid materials. A single microphone in the LHC tunnel can be used to monitor collimators located in distances up to several meters from the microphone. The time delay of the

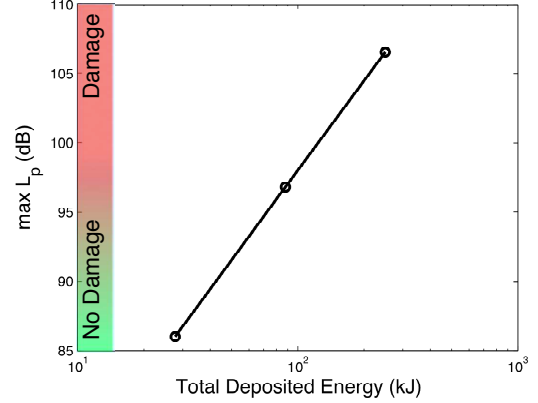

Figure 8: Sound pressure level vs. total deposited energy for test cases listed in Table 1. Linear interpolation yields a reference curve which can be used to estimate the damage extend from the sound pressure level.

sound can be used to determine the impacted collimator. The maximal sound pressure is determined to estimate the damage level.

However, the shown reference curve is only valid for the HiRadMat setup. Investigation of the room acoustics is needed to determine a measure that is only dependent on the sound source, e.g. the sound power. Furthermore, a better understanding of the excitation of vibrations due to beam hits will improve the overall performance of damage estimation.

The contribution of various teams to this experiment is highly acknowledged: HiRadMat team, DGS-RP (C. Theis, K. Weiss), EN-STI (C. Derrez, R. Bebb), SPS-OP (K. Cornelis), BE-ABP (R. Bruce, B. Salvachua, G. Valentino) and EN-MME (F. Carra, M. Guinchard).

REFERENCES

- [1] A. Bertarelli et al., “Updated Robustness Limits for Collimator Materials”. Anecy Workshop 2013, Anecy, France, 2013.
- [2] C. Cauchi et al., “Preliminary Assessment of Beam Impact Consequences on LHC Collimators”. IPAC’11, San Sebastian, September 2011.
- [3] M. Cauchi et al., “High Energy Beam Impact Tests on a LHC Tertiary Collimator at CERN HiRadMat Facility”, These Proceedings, Shanghai 2013.
- [4] A. Dallochio, “Study of Thermo-Mechanical Effects Induced in Solids by High Energy Particle Beams: Analytical and Numerical Methods”, PhD Thesis, April 2008.
- [5] D. Deboy et al., “Acoustic Measurements in the Collimation Region of the LHC”, IPAC’11, San Sebastian, September 2011, THPZ031.
- [6] A. Fasso et al., “FLUKA: A Multi-Particle Transport Code”, CERN-2005-10(2005), INFN/TC_05/11, SLCR-773.
- [7] S. Redaelli et al., “Detecting Impacts of Proton Beams on the LHC Collimators with Vibration and Sound Measurements”. In Proceedings of PAC 2005, Knoxville, Tennessee, 2005.