

**FLASHBOX COMPACT BEAM SPECTROMETER AND ITS
APPLICATION TO THE HIGH-GRADIENT ACCELERATION STUDY**

Alexey Dubrovskiy (JINR, Dubna and CERN, Geneva), Frank Tecker (CERN,
Geneva),
Marek Jacewicz, Roger Ruber, Volker Ziemann (Uppsala University, Uppsala)

Abstract

A Flashbox compact spectrometer has been developed for the Two-beam Test Stand (TBTS), which is a part of the CLIC test facility CTF3 at CERN. It is used to study RF breakdown currents emitted from high gradient X-band accelerating structures being prototyped in the TBTS. The Flashbox is built around the beam tube such that an electron beam can pass to be accelerated in the accelerating structure while charged particles emitted from the structure can be intercepted on the spectrometer consisting of detector plates aligned along the beam axis in combination with magnetic and electric fields. The Flashbox has made it possible to identify electrons and ions emitted by the accelerating structure during RF breakdowns. We describe the Flashbox and first results.

Presented at the International Particle Accelerator Conference (IPAC'13) –

May 12-17, 2012, Shanghai, China

Geneva, Switzerland, May 2013

FLASHBOX COMPACT BEAM SPECTROMETER AND ITS APPLICATION TO THE HIGH-GRADIENT ACCELERATION STUDY

Alexey Dubrovskiy (JINR, Dubna and CERN, Geneva), Frank Tecker (CERN, Geneva),
Marek Jacewicz, Roger Ruber, Volker Ziemann (Uppsala University, Uppsala)

Abstract

A Flashbox compact spectrometer has been developed for the Two-beam Test Stand (TBTS), which is a part of the CLIC test facility CTF3 at CERN. It is used to study RF breakdown currents emitted from high gradient X-band accelerating structures being prototyped in the TBTS. The Flashbox is built around the beam tube such that an electron beam can pass to be accelerated in the accelerating structure while charged particles emitted from the structure can be intercepted on the spectrometer consisting of detector plates aligned along the beam axis in combination with magnetic and electric fields. The Flashbox has made it possible to identify electrons and ions emitted by the accelerating structure during RF breakdowns. We describe the Flashbox and first results.

INTRODUCTION

One of the main challenges of the CLIC e^+e^- linear collider is to fabricate normal conducting accelerating structures that sustainably perform at 100 MV/m [1]. The stored field in the structures is perturbed by accidental RF breakdowns (BD). In order to archive a high luminosity of up to $2 \times 10^{34} \text{ cm}^{-2} \text{ s}^{-1}$ the RF breakdown rate is required to be at the level of $10^{-7} \text{ BD}/(\text{pulse} \cdot \text{meter})$. The CLIC test facility CTF3 hosts the two beam test area TBTS, where prototypes of CLIC accelerating structures are being tested at gradients up to 150 MV/m.

The Flashbox detector has been developed in order to provide additional instrumentation, which has a unique ability to measure properties of emitted electrons and energetic ions at high gradients during the two-beam acceleration tests. The results of these measurements will contribute to the development of the breakdown theory and to the validation of accelerating structures by providing data about charged particles under different RF conditions. In this paper the setup and program of the experiment is introduced, and the first results are discussed.

SETUP

The experiment has been set up in the TBTS area, which is devoted to two beam acceleration and deceleration studies [2]. The electron drive beam with a current up to 30A generates RF power in the power extraction structure (PETS). High-power movable RF short circuits installed at the beginning and at the end of PETS permit extracting RF peak power of over 200 MW from the drive beam. The extracted power is the RF source for high-gradient studies of normal conducting accelerating structures at a length of 20 cm installed in the parallel probe beam line (Fig. 1). The short circuits allow controlling the level of the extracted RF power and therefore controlling the accelerating gradient. The acceleration gradient of 150 MV/m was measured with the probe beam. The probability of a breakdown in the structures grows with a strong dependence on the accelerating gradient. The setup has been equipped with various diagnostic tools giving an opportunity to study breakdown phenomena in different conditions, in which the breakdown rate can reach a level higher than $10^{-3} \text{ BD}/\text{pulse}$, and to accumulate a large number of data.

The Flashbox detector is installed in the probe beam line downstream from two accelerating structures at a distance from them of 1m and 1.5m respectively. There is one steering dipole magnet between the structures and Flashbox, which allows controlling the spectrum range of emitted charged particles measured by the detector. The Beam Position Monitors (BPM) in the line provide additional information like mean position and intensity of high energy particles, which were not measured in the Flashbox due to a weak deflection angle.

Each lateral side of the Flashbox contains 8 Ag or Cu detector plates, on which impacting particles deposit their charge (Fig. 2). The detector plates are located on one side of a ceramic slab made of Al_2O_3 with the electric ground located on the other side of the slab. In that way the detector plate forms a capacitor, which is charged by

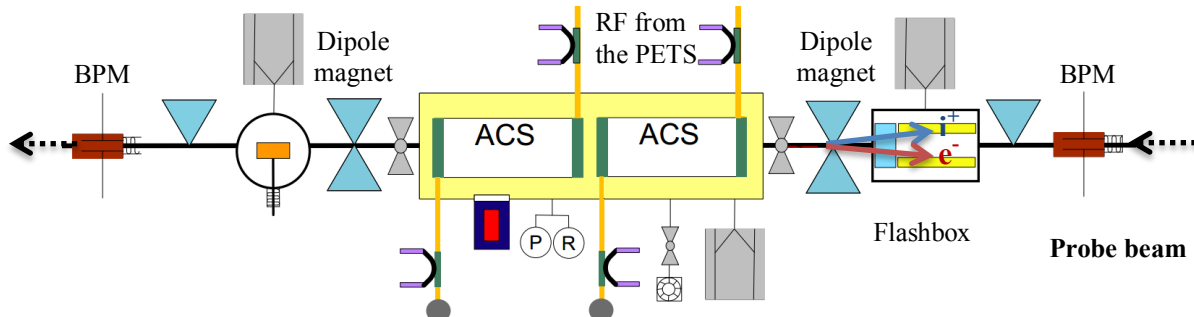

Figure 1: TBTS probe beam line layout.

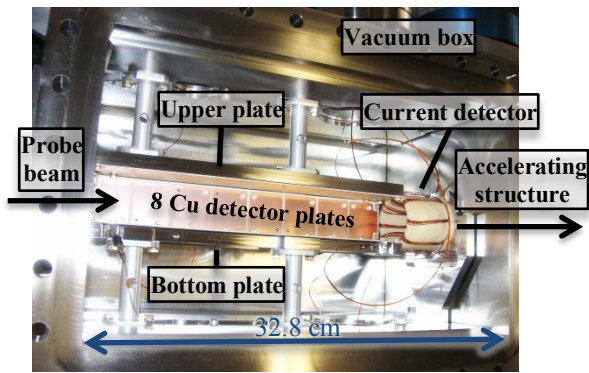

Figure 2: Flashbox picture

the impacting particles and subsequently discharge via a 50Ω resistance. The bandwidth of the signals is a few hundred MHz, which is sufficient to observe emission processes with fast ADCs even for relativistic particles. The coupling between plates was designed and measured to be below -40 dB. An adjustable electric potential is applied on each detector plate in order to suppress secondary emissions: typically, -2.5 V for the ion detection on the Ag plates and $+2.5$ V for the electron detection on the Cu plates.

In addition to the detector plates Flashbox contains a current detector (toroid), which allows measuring the integrated charge of particles passing through it.

OPERATION

Although the Flashbox is suitable for the operation in the two-beam acceleration mode the common mode of operation is when only the drive beam is on. This is due to the fact that the electromagnetic interference from the probe beam can affect the signals, because the plates work in the same way as inductive pick-ups. That limits the time window of the useful part of the signals.

The trigger for RF breakdown events is derived from the RF transmission and reflection, light detector and Faraday cup signals installed in TBTS. During the experiment the drive beam powers the setup for up to a couple of days in a row, which is sufficient to detect several breakdown events with almost identical initial RF conditions. The spectrum of emitted particles is nevertheless very different for each breakdown. A better understanding of this effect will be possible with a larger number of breakdowns.

PROGRAM

The main goal of the experiment is to find ions and to measure the time resolved energy spectrum of charged particles with their mass-to-charge ratios at different initial RF conditions (Fig. 3). The challenge is that the detectable part of the spectrum does not cover the full possible range and the spectrum of breakdowns is not reproducible. In order to approach to our goal an experiment program has been worked out. It is foreseen to scan the energy spectrum by applying nine dipole magnet settings, and for each setting to measure 150 breakdowns

at least at three different RF power levels. In total it is expected to measure about 1500 breakdowns. Since the breakdown rate varies from 10^{-6} to 10^{-3} the required time to take measurements significantly varies from a couple of months to many years at the CTF3 repetition rate of 0.8 Hz. In order to increase the probability of finding ions, cursory scans will be applied. At the same time the time resolved spectrum of emitted electrons up to 10 MeV will be measured. The bottom detectable energy threshold is bound by the noise-to-signal ratio of the ADC. It is also expected that slow ions will reach the detector within 1 ms after the breakdown.

OBTAINED RESULTS

The main Flashbox results were obtained in the configuration with only one accelerating structure installed in the tank. The distance in between the Flashbox and the structure was 1.7 m.

Measurements showed that the enhanced electron emission starts at the same time when the RF reflection starts abruptly increasing and the RF transmission starts ceasing, which are the typical signs of an RF breakdown. It ends when the RF incident power is lower. The duration of the electron emission was measured up to 250 ns for an RF pulse with the duration of about 400 ns and the peak power of 90 MW (Fig. 4). The intensity of emitted electrons was measured up to about 0.2 A by upstream and downstream BPMs, when no magnetic field was applied. Energy distributions are derived from the inter-plates interpolation of the Flashbox signals and the applied magnetic and electric fields, which steer charged particles towards the plates. Up to 7% of electrons estimated from the BPM and plates signals had energy above 1 MV but below 4 MV, and up to 7% of electrons had energy below 10 kV. The energy of electrons has always been measured below a maximum energy, which an electron could gain in three cells of the accelerating structure with the phase advance of $2\pi/3$.

By now only one type of ion has been detected. The mass-to-charge ratio was estimated between 1.2 u/e and 2.5 u/e and the velocity was estimated between 0.4% and 0.6% of the speed of light (Fig. 5). It could be, for

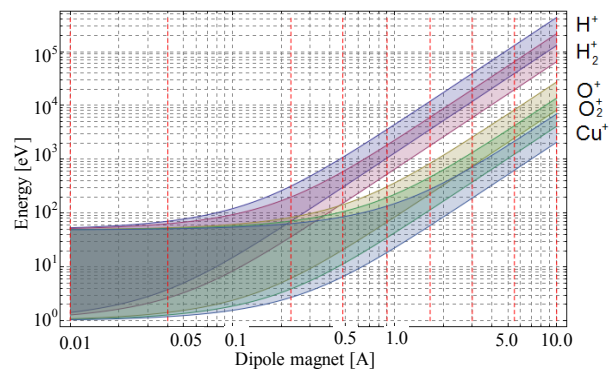

Figure 3: Ion search program. The shaded areas show visible energy ranges by the detector for different ions at all possible dipole strengths (0.450 mT/A). The red lines mark nine dipole strengths in the program.

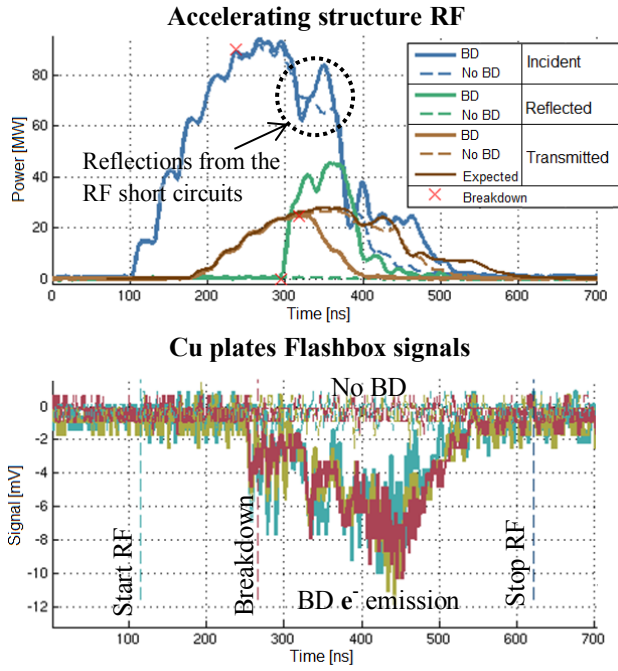

Figure 4: Electron emission during an RF breakdown: RF power (top) and signals from Cu plates (bottom). The energy of detected electrons is below 10 kV.

example, any of the following ions: H_2^{+1} (14-30 kV), He^{+2} (29-58 kV), Cu^{+26} (470-920 kV) etc. But there are three indications that it was H_2^{+1} :

1. The accelerating structure passed a hydrogen treatment, but after that it did not have any high-temperature baking, which normally would eliminate the residual hydrogen from the wall [3].
2. The source of energetic hydrogen could be desorption from the wall during the breakdown plasma dilation [4].
3. The set of two new structures were baked before to be installed in TBTS and no sign of energetic ions has been detected so far.

CONCLUSIONS

The Flashbox detector has been successfully developed, installed and commissioned. The data acquisition system has been integrated into the TBTS data acquisition system, which allows correlating Flashbox signals with RF, BPM, vacuum and the other beam and breakdown diagnostic signals. The developed offline analyses tools provide reconstructions of the time resolved energy spectrum of emitted charged particles after breakdowns at the exit of the structure. The first spectra of electron emission have been measured in the range between 1 kV and 4MV during breakdowns at accelerating gradients of about 140 MV/m. The evidence of the H_2^{+1} ion emission has been obtained for the first accelerating structure, where the emission occurrence was possibly the result of a missing baking step during the fabrication process. The program continues searching for further evidence of ion

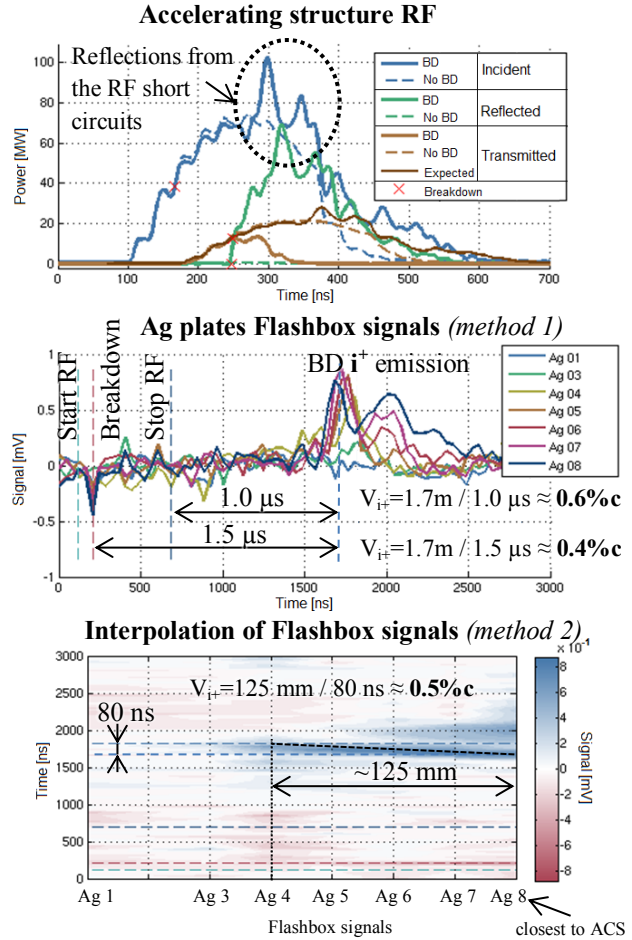

Figure 5: Ion emission during an RF breakdown and estimation of velocity of ions V_{i+} using two methods: 1) relative to the breakdown and stop RF and 2) absolute from the inter-plates interpolation of the Flashbox signals from Ag plates.

emissions and reconstructing of time resolved energy spectra of the electron emission.

ACKNOWLEDGMENT

The authors acknowledge the whole CTF3 operation team for setting up the beam. The authors especially acknowledge Walter Wuensch and Sergio Calatroni for the help to interpret the results with H_2^{+1} .

REFERENCES

- [1] A Multi-TeV linear collider based on CLIC technology: *CLIC Conceptual Design Report* edited by M. Aicheler et al. 2012.
- [2] W. Farabolini et al., *Two Beam Test Stand Experiments in the CTF3 Facility*, IPAC11, 2011.
- [3] Walter Wuensch and Sergio Calatroni, *private communications*, CERN, 2012.
- [4] I. Martini, Master Degree Thesis: *Copper for particle accelerators: electron stimulated desorption and study of hydrogen content measurement by laser ablation*, Politecnico di Milano, 2011.