

VALIDATION OF THE CLIC ALIGNMENT STRATEGY ON SHORT RANGE

H. Mainaud Durand, M. Anastasopoulos, S. Griffet, J. Kemppinen, V. Rude, M. Sosin

CERN, Geneva, Switzerland

Abstract

The pre-alignment of CLIC consists of aligning the components of linacs and beam delivery systems (BDS) in the most accurate possible way, so that a first pilot beam can circulate and allow the implementation of the beam based alignment. Taking into account the precision and accuracy needed: 10 μm rms over sliding windows of 200m, this pre-alignment must be active and it can be divided into two parts: the determination of a straight reference over 20 km, thanks to a metrological network and the determination of the component positions with respect to this reference, and their adjustment.

The second part is the object of the paper, describing the steps of the proposed strategy: firstly the fiducialisation of the different components of CLIC; secondly, the alignment of these components on common supports and thirdly the active alignment of these supports using sensors and actuators. These steps have been validated on a test setup over a length of 4m, and the obtained results are analysed.

Presented at: IWAA2012, Fermilab, Batavia, US, 10-14 September 2012

Geneva, Switzerland,
October 2nd, 2012



VALIDATION OF THE CLIC ALIGNMENT STRATEGY ON SHORT RANGE

H. Mainaud Durand, M. Anastasopoulos, S. Griffet, J. Kemppinen, V. Rude, M. Sosin, CERN, Geneva, Switzerland

Abstract

The pre-alignment of CLIC consists of aligning the components of linacs and beam delivery systems (BDS) in the most accurate possible way, so that a first pilot beam can circulate and allow the implementation of the beam based alignment. Taking into account the precision and accuracy needed: 10 μm rms over sliding windows of 200m, this pre-alignment must be active and it can be divided into two parts: the determination of a straight reference over 20 km, thanks to a metrological network and the determination of the component positions with respect to this reference, and their adjustment.

The second part is the object of the paper, describing the steps of the proposed strategy: firstly the fiducialisation of the different components of CLIC; secondly, the alignment of these components on common supports and thirdly the active alignment of these supports using sensors and actuators. These steps have been validated on a test setup over a length of 4m, and the obtained results are analysed.

INTRODUCTION

CLIC (Compact Linear Collider) is a study for a future multi TeV electron positron collider [1]. One of the key issues is the preservation of ultra-low emittances and nanometer beam size. This can only be achieved with beam based alignment of components, implemented once these components have been pre-aligned to about 10 μm over a distance of several betatron wavelengths (200 m). Taking into account normal seismic ground movement and cultural noise, as well as the impact of environment variations (temperature, humidity, etc.), such tolerances of pre-alignment can be achieved using an active pre-alignment system which will be linked to a permanent metrological network: the position of the components will be determined continuously when beam is off by alignment sensors, and re-adjusted, when needed, by actuators.

The determination of the position of the components will be performed in two steps:

- The determination of a straight alignment reference line all along the main linac and Beam Delivery System (BDS) by a permanent metrological network. In the Conceptual Design Report, a solution based on 2 parallel lines of stretched wires has been proposed. The wires are overlapping over half of their length and their distance from each other is determined at better than 5 μm by Wire Positioning Sensors (WPS) located on the same plate. The WPS sensors measure the radial and

vertical offsets with respect to stretched wires with a sub-micrometric resolution. The WPS relative positions have been determined at the micron level in a Coordinate Measuring Machine (CMM) in a metrology laboratory.

- The measurements of WPS sensors that are located on the components to be determined in position (or on their associated support in case of an assembly of components) [2].

This strategy can be efficient only if the coordinate system of the WPS sensors is known at the micron level in the support coordinate system and at a few microns with respect to the reference axis of each component. The reference axis of each component can be a magnetic axis in case of a quadrupole or dipole, an electrical zero in case of a BPM, or a mechanical axis in case of an RF component. To fulfil this requirement, the steps below must be followed, the whole process being a matter of linking coordinate systems by metrological measurements [3]:

- o Fiducialisation of each component in order to determine the position of the fiducials (alignment targets) located on the outer cover of the component w.r.t its reference axis
- o In case of an assembly of components, each component will be pre-aligned on a common support within a few microns, and the position of its fiducials will be determined in the coordinate system of the support within a few microns.
- o Sensors will be associated to each support to be aligned, and the coordinate system of each sensor will be determined in the coordinate system of the support within a few microns.

This paper details the steps presented above, composing the second part of pre-alignment, and presents the first associated results obtained on two test setups.

ALIGNMENT STRATEGY ON SHORT RANGE

Two beam acceleration concept and modules

CLIC technology is based on the two beam acceleration concept, where two beams run in parallel in the main linac: the Drive Beam (DB), a high intensity and low energy beam, is decelerated into Power Extraction and Transfer Structures (PETS) and the generated RF power is transmitted to the Accelerating Structures (AS) of the Main Beam (MB). Therefore, the two $e^- e^+$ main linacs will each consist of more than 10000 modules with a

length of 2 m. There will be 5 types of modules, depending on the length of the quadrupole along the Main Beam: from 0 m (no quadrupole) to 2 m long quadrupole (MB quad), with AS completing from 2 m (8 AS) to 0 m (no accelerating structures) (see Figure 1). Each Drive Beam side of a module consists of 2 DB quadrupoles and the number of PETS necessary to supply the accelerating structures, e.g. one PETS supplying two AS.

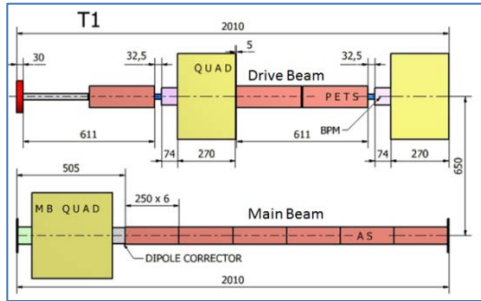

Figure 1 : Configuration of module type 1

Each component has its own budget of error concerning its positioning with respect to the straight alignment reference, summarized in table 1 below [4].

Table 1 : Radial and vertical error of positioning (1σ) of the components

Component	Max error	Reference
MB quadrupole	17 μm	Magnetic zero
MB quad BPM	14 μm	Electrical zero
DB quadrupole	20 μm	Magnetic zero
DB quad BPM	20 μm	Electrical zero
Accelerating structures (AS)	14 μm	Mechanical axis
PETS	100 μm	Mechanical axis

The short range strategy of pre-alignment consists of linking coordinate systems through micrometric measurements.

Fiducialisation of each component

Taking into account the micrometric accuracy requirements of this step, the fiducialisation of the components will be performed by CMM measurements: the mechanical axis of each component will be determined with respect to fiducials. The link between mechanical axis and electrical zero or magnetic zero will have to be determined in parallel by other means that are not developed in the scope of this paper.

A variety of fiducials (Figure 2) has been designed in order to be adapted to the available space on the components, from the standard 0.5" and 1.5" ball holders to conical bores in which small magnets can be inserted to hold the Corner Cube Reflector. All these fiducials are then glued on the components [4].

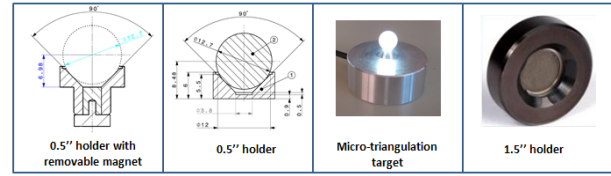

Figure 2 : different types of fiducials

Tri-dimensional coordinate machines carry out micrometric measurements in the dedicated area of the metrology laboratory. Very accurate measurements will also be needed in the test setups, and later in the tunnel. Consequently, alternative means have been proposed and tested: Leica absolute tracker AT401, Romer Portable measuring arm (Romer arm) and Micro-Triangulation (development in collaboration with ETHZ). The methods of measurements were validated through inter-comparison measurements on a metrological plate equipped with different types of targets, all determined by very accurate CMM measurements (Leitz Infinity): $0.3 \mu\text{m} + 1 \text{ppm}$ (MPEE, ISO 10360-2), considered as the reference. The standard deviation between instruments and CMM measurements were inferior to $5 \mu\text{m}$ in the case of AT401 and Micro Triangulation and inferior to $10 \mu\text{m}$ in the case of Romer arm [4].

Alignment on a common support

To facilitate the alignment process and to limit the cost, several components are pre-aligned mechanically on a common support. The active pre-alignment will be performed on this support, which is equipped with the mechanical interfaces of alignment sensors and supported by actuators.

The cylindrical external reference surfaces of the RF components (PETS and accelerating cavities) will be fastened on V-shaped supports that are aligned on a common girder: their mean axis (corresponding to the theoretical beam) will be included in a cylinder with a radius of $5 \mu\text{m}$ for each girder along a maximum length of 2 m. On the DB side, two quadrupoles per girder will have to be aligned with respect to the mean axis of the V-shaped supports. Intermediate adjustment devices located between the upper girder surface and each quadrupole will allow such micrometric adjustment, controlled by laser tracker measurements. This step requires that each girder was fiducialised by CMM measurements before the installation of the components: the mean axis of the V-shaped supports is known with respect to fiducials distributed all along the girder.

The case of MB quadrupole is not the same as that of the previous components. This component, with its associated MB quad BPM, will have to be stabilized at the nanometric scale when beam is on. This means that after fiducialisation of the whole assembly: support + stabilization devices + components, in a given position of the stabilization devices, the parameters will have to be updated each time nanometric displacements are performed by the stabilization devices.

Reference system of alignment sensors

The 3 balls mechanical interface of alignment sensors must be measured during the fiducialisation process of the support. These interfaces were developed to be measured easily and accurately by metrological means. For example, concerning WPS sensors based on capacitive technology (cWPS), the reference system is defined by the centre of 3 ceramic balls grade* 40 [5]. Mechanical systems have been designed to allow a repeatable installation and fastening of each sensor equipped with a kinematic interface on the 3 balls.

An adequate interface remains to be developed for the biaxial inclinometers that are also part of the strategy to determine the position of the components. The same interface as for cWPS was used, but it is not accurate enough for angle measurements at the micro-radian level. As a matter of fact, at the scale of an inclinometer interface (7 cm long), the determination of the ceramic balls location at 1 μm will produce as a consequence an angle incertitude of 14 μrad [6].

Adjustment solutions

Two types of adjustment solutions are currently under study: the first solution, based on cam movers, allows 5 degrees of freedom (DOF) of motorized adjustments; the second solution, based on articulation point between adjacent girders and linear actuators, allows also 5 DOF.

Eccentric cam movers are under development to provide sub-micrometric resolution of displacement over a stroke of ± 3 mm, according to 5 DOF, of the Main Beam quadrupole support [7]. Because of nanometric requirements concerning vertical displacements of the quadrupole above 100 Hz, stiffness has to be provided to the support assembly with such a mechanical solution. The configuration of cam movers below the support has been optimized:

- 5 cam movers to provide 5 DOF
- A kinematic mount interface
- 4 interfaces with ground for higher stiffness.

The concept of articulation point concerns all the girders located along the same beam (drive beam or main beam). Each girder is equipped at its extremities with one master cradle and one slave cradle. The master cradle is equipped with alignment sensors. The RF components are fastened on V-shaped supports; the centre of which is included in a cylinder with radius of 5 μm . The articulation point is the intersection of the mean axis of the V-shaped supports of two adjacent girders, in the vertical plane located between the cradles. The articulation point is mechanically built in such a way that it remains located in radius of 5 μm over the whole stroke of displacement (± 3 mm). Each master is supported by 3 linear actuators (2 vertical and one radial) allowing 3

* Ceramic balls are manufactured to a specific grade defining their geometric tolerances. For grade 40, this means a basic diameter tolerance of ± 2.50 μm , a ball diameter variation of ± 1.00 μm , a deviation from spherical form of ± 1.00 μm , a surface roughness of ± 0.08 μm and an allowable lot diameter variation of ± 2.00 μm .

DOF (vertical, radial and roll); the articulation will transmit vertical and radial displacements within 1 μm to the slave cradle, but not the roll [8]. As the position of the mechanical interface of the sensors was measured within a few microns with respect to the mean axes of the V-shaped supports, the readings of the sensor fastened on the interface allow the determination of the real position of the mean axis (and of the components) with respect to the metrological network. If needed, a re-adjustment is performed with the actuators.

This whole strategy is being tested and validated on two test setups: the first one consists of two modules: “modules test setup”, the second one consists of a Main Beam quadrupole support with a length of 2m: “cam mover test setup”. These setups are introduced in the next chapter, as well as the first results obtained.

MODULE TEST SETUP AND ASSOCIATED RESULTS

Description

The module test setup has been implemented to demonstrate the two beam module design, i.e.:

- The assembly and integration of all the components and technical systems (vacuum, stabilization, alignment, beam instrumentation, supporting, RF components and their associated water cooling and waveguides). Dummy RF structures and quadrupoles have been manufactured, with real weight and interfaces to other systems.
- The validation of some sub-systems such as vacuum, supporting and alignment. Concerning the alignment, the two main objectives are to validate the fiducialisation strategy according to different configurations of girders and actuators, and to validate the pre-alignment strategy on short length.

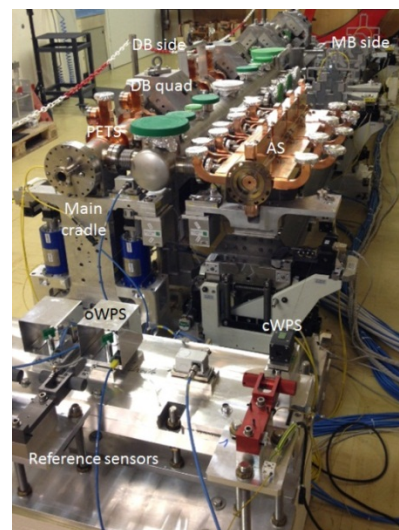

Figure 3 : module test setup

The test setup (Figure 3) is currently installed in a laboratory environment; it is also planned to be tested in an accelerator environment, with a real beam.

The module test setup consists of 2 modules, which means two 2 m long girders linked by articulation points (Figure 4).

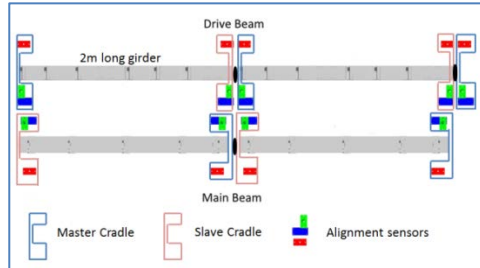

Figure 4 : configuration of module test setup

V-shaped supports were manufactured on top of the girders to support RF components, as well as reference planes on the drive beam girder to support DB quadrupoles.

In this prototype configuration, the number of sensors was multiplied by 4, master and slave cradles were equipped with two different types of alignment sensors: optical WPS (oWPS) and capacitive WPS (cWPS). Two supporting solutions are tested:

- an “all in one” solution proposed by an external company (solution 1), including actuators, cradles, girders, V-shaped supports and articulation point
- a CERN solution (solution 2) concerning the design of the cradles and articulation points, combined with girder, V-shaped supports and linear actuators manufactured in industry.

Results concerning the fiducialisation

The mean axis of the V-shaped supports has been determined through CMM measurements with an uncertainty of measurement of $\pm 6 \mu\text{m}$ at 3σ . Concerning the solution 1, the radius of the cylinder containing the center of the V-shaped supports was $6 \mu\text{m}$ and $4 \mu\text{m}$, while for the solution 2, the radius was $7.5 \mu\text{m}$ and $5.5 \mu\text{m}$.

The measurement of the mechanical axis of the components with respect to fiducials was performed on the Leitz Infinity CMM.

Concerning the fiducialisation of the girder assembly (mean axis of the V-shaped supports with respect to mechanical interfaces of alignment sensors located on the cradles), the volume of measurement of the CMM in use at CERN was not sufficient: the total length of the girder + cradles was above 2m, with a necessity to measure also some reference pin holes at each extremity. Different types of fiducials implied different types of measuring devices, with sometimes measurements outside the range of measurement. The accuracy of measurement determination obtained was estimated to be $\pm 15 \mu\text{m}$, through cross-checks by other instruments as AT401 and Romer Arm [4].

Results concerning the alignment on a common support

The determination of the position of the DB quadrupole on its interface plane on top of the girder with respect to the mean axis of the V-shaped supports was performed using laser tracker AT401 and Micro-Triangulation measurements, with a precision and accuracy better than $10 \mu\text{m}$, using the alignment targets as reference. But it appeared that the adjustment system did not allow a sufficient resolution. Consequently, an alignment of the DB quadrupole worse than $20 \mu\text{m}$ was obtained in the girder coordinate system [4].

The alignment of other components is under progress, and no results are available at this stage.

Results concerning the sensor mechanical interface

A very good repeatability and reproducibility was obtained when installing and fastening the sensors on their mechanical interfaces: less than $2 \mu\text{m}$ for WPS sensors, less than $3 \mu\text{rad}$ for biaxial inclinometers, even when these sensors were installed “head down” [9].

Adjustment system

The validation tests carried out on the two solutions of articulation points demonstrated a very good follow-up of the slave cradle with respect to the master cradle, within $1 \mu\text{m}$ over the whole stroke of actuators. In both solutions, the roll of one girder is not transmitted to the adjacent girder. But an impact of the loads appeared on the roll and in the radial adjustment of the girder, as the mechanical rotation is not performed at the level of the mean axis of the V-shaped support [9].

Active adjustment of the master cradle and its associated girder, based on sensor readings and fiducialisation, has been validated successfully for relative measurements. The closed loop algorithm was convergent in maximum 2 regulation cycles at the micron level for shifts lower than $\pm 0.5 \text{ mm}$ on vertical and radial axes. The trajectory following test based on a list of coordinates of points as targets of displacements was also successful even though sensor noise was affecting the final regulation quality [10].

Validation of the global strategy of pre-alignment

Two independent strategies for the determination of the mean axis of the V-shaped supports were compared:

- Determination of the axes using fiducials located on the girders themselves and AT401 measurements, associated with the fiducialisation measurements of the girder.
- Determination of the axes using oWPS and cWPS readings, associated with the fiducialisation measurements of the sensor interfaces [11].

The coordinates of the extremities C1 and C2 of the mean axis of the V-shaped supports (for girders MC1 and MC2) were calculated by both methods, see Figure 5.

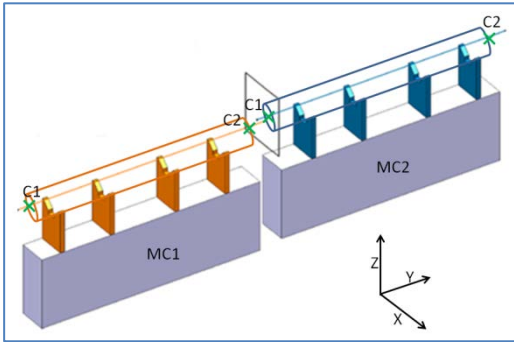

Figure 5 : Configuration of two adjacent girders

The difference between these coordinates is very low, as shown in Table 2 below, which confirms the precision and accuracy of both strategies.

Table 2 : Difference between coordinates of mean axis extremities calculated by two different methods

	X (mm)	Z (mm)
MC1-C1	-0.005	0.012
MC1-C2	0.010	-0.005
MC2-C1	-0.001	-0.004
MC2-C2	-0.011	-0.007

CAM MOVER SETUP AND ASSOCIATED RESULTS

Description

The cam mover setup consists of 5 cam movers, on top of which lays a specifically designed support (see Figure 6). Interfaces for cWPS and bi-axial inclinometers are installed on top of the support. The coordinates of the ceramic fiducialisation balls of the interfaces in the support coordinate system have been determined by CMM measurements. Thus, once the alignment sensors are fastened, the support's position is determined redundantly in 5 DOF. Additional targets have been installed to ease the initial installation and for complementary tests. Two concrete blocks are located on each side of the test setup: they host alignment sensors which will provide an independent reference of alignment while the support is displaced by the cam movers.

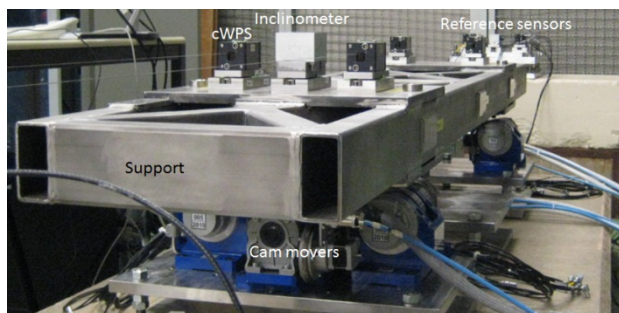

Figure 6 : cam mover setup

The objective of the cam mover setup is to validate the proposed configuration of cam movers for sub-micrometric displacements: resolution of displacement along the whole range, repeatability, tests of the algorithm of repositioning, impact of heating of motors.

Latest results

The radial and vertical resolution throughout the displacement range is inferior to $1 \mu\text{m}$. The repeatability of a movement is between $1 \mu\text{m}$ and $3 \mu\text{m}$. The precision of a single displacement depends heavily on the length of the displacement and on along which degrees of freedom the movement is applied and is between $20 \mu\text{m}$ and $200 \mu\text{m}$.

CONCLUSION

The alignment strategy on short range consists of a very accurate determination of the coordinate systems of the components, of their support assembly, of the sensor, combined with a micrometric adjustment. This strategy is being validated on test setups; the first lessons learnt are the following:

- CMM measurements are the most precise and accurate, provided that the component or its support is shorter than the volume of measurement
- CMM measurements of fiducials as a first step, and AT401 combined with Romer arm measurements as a second step on the field of work provide the best solution for micrometric alignments on site. The determination of the position of components was better than $10 \mu\text{m}$ in a stable environment
- Standard means of adjustment (shimming,...) can't be applied without added value for micrometric adjustment

The first obtained results show that the followed strategy can be successful. The problem is that only the mechanical axis of the components was considered and not their electrical zero or magnetic zero. The determination of this last step has to be taken into consideration in the final budget of alignment error. One solution would be to perform this last step in the CMM at the same time than fiducialisation: the same stretched wire would be used as a reference of alignment for alignment sensors, magnetic zero and electrical zero. This concept will be the object of further developments.

REFERENCES

- [1] CLIC Study web site: <http://clic-study.org>
- [2] H. Mainaud Durand et al., "CLIC active pre-alignment system: proposal for CDR and program for TDR", IWAA 2010, DESY, 2010
- [3] T. Touz , "Feasibility of the CLIC metrological reference network", IWAA 2010, DESY, 2010
- [4] S. Griffet et al., "Strategy and validation of fiducialisation for the pre-alignment of CLIC components", IPAC 2012, New Orleans, 2012.

- [5] H. Mainaud Durand et al., oWPS versus cWPS, these proceedings
- [6] T. Touzé, « Proposition d'une méthode d'alignement de l'accélérateur linéaire CLIC : des réseaux de géodésie au pré-alignement actif », PhD thesis, Université Paris Est, 2011, CERN-THESIS-2011-071
- [7] H. Mainaud Durand et al., "Validation of a micrometric remotely controlled pre-alignment system for the CLIC linear collider using a test setup (mock-up) with 5 degrees of freedom", IPAC 2011, San Sebastian, 2011
- [8] H. Mainaud Durand et al., "Theoretical and practical feasibility demonstration of a micrometric remotely controlled pre-alignment system for the CLIC linear collider", IPAC 2011, San Sebastian, 2011
- [9] V. Rude, "tests performed on two test modules in lab", CERN, 2011, edms n°1158386.
- [10] M. Sosin et al., "Issue and feasibility demonstration of positioning closed loop control for the CLIC supporting system using a test mock-up with 5 degrees of freedom", IPAC 2012, New Orleans, 2012
- [11] V. Rude, « Rattachement des plaques aux extrémités de la maquette test module », edms n°1234570, CERN, 2012.