

POSSIBILITY OF A HIGHER PSB TO PS TRANSFER ENERGY

O. Aberle, A. Blas, J. Borburgh, D. Bozzini, M. Buzio, O. Capatina, C. Carli, T. Dobers, L. Fernandez, A. Findlay, R. Folch, S. Gilardoni, N. Gilbert, K. Hanke, T. Hermanns, E. Mahner, B. Mikulec, A. Newborough, M. Nonis, S. Olek, M. Paoluzzi, S. Pittet, I. Ruehl, G. Rumolo, R. Steerenberg, J. Tan, D. Tommasini, W. Weterings, M. Widorski, CERN, Geneva, Switzerland

Abstract

Following the Chamonix 2010 workshop a task force has been set up to study the feasibility and the impact of an energy upgrade of the PS Booster from the present 1.4 GeV to about 2 GeV. The working group has confirmed the feasibility of such an upgrade, and analysed in detail the impact on the accelerator hardware along with a cost estimate and a tentative planning. The outcome of the task force will be summarized, with particular emphasis on the remaining limitations, risks and uncertainties.

INTRODUCTION

One of the outcomes of the 2010 Chamonix workshop [1] was that an increase of beam energy from 1.4 GeV to about 2.0 GeV would ease injection of high intensity and high brilliance beams into the PS [2], and thus help removing bottlenecks in the injector chain. Given that consolidation of the ageing machine would be required anyway to allow for reliable operation throughout the lifetime of the LHC, the question was raised whether such an energy upgrade could be done, and what resources would be needed in addition to the consolidation program. The task force set up immediately after the workshop has tried to cover the complete accelerator hardware and all aspects of operation, in order to obtain an as complete picture as possible of the technical modifications that would be needed and the impact in terms of resources. The task force was also mandated to evaluate the time lines of such a potential upgrade, taking into account that work in the injectors would be constrained by the long LHC shutdowns.

The following items have been addressed by the working group, composed of representatives of the various groups involved*:

- beam dynamics
- magnets and magnetic measurements
- RF system
- beam intercepting devices
- power converters
- vacuum system
- instrumentation
- commissioning and operation
- extraction and transfer
- controls
- electrical systems
- cooling and ventilation
- radiological protection

- transport and handling
- survey

Further working group members were representatives of the consolidation program, the design office, the US-LARP collaboration, experts of the PS machine and other specialists as needed.

The findings of the working group have been published in [3]. In the following sections the areas with significant impact will be addressed in detail.

GENERAL CONSIDERATIONS

The mandate of the study group was to consider 2 GeV energy for LHC type beams in the PSB only. However, at a very early stage of the investigations it became clear that the cost drivers would not change when extending the energy upgrade to all beams. The baseline scenario is therefore to enable the machine to execute every cycle at 2 GeV. At the same time, it is suggested to upgrade the Booster to PS transfer line (BTP) for ppm (pulse-to-pulse modulation) operation. The Booster itself and the injection into the PS are already fully ppm. This means that the complete Booster including the transfer line and PS injection would be able to alternate between 1.4 GeV and 2 GeV cycles from cycle to cycle if needed. This scenario gives the maximum operational flexibility. Modification of the transfer line to ISOLDE (BTY) was not considered within the frame of this study. It is therefore assumed that ISOLDE beams remain at the present energy of 1.0/1.4 GeV. In case ISOLDE would like to take advantage of 2 GeV beams, this would require a separate project with its own budget.

For completeness we have studied a scenario where we would not do the ppm upgrade of the BTP line (which would mean moderate cost savings) and execute only LHC type beams at 2 GeV. In that case one would need to suppress 1.4 GeV fixed-target physics cycles whenever LHC type beams are present in the injectors (i.e. during LHC filling but also during setting up). We found that such a scenario would yield some moderate cost savings, while the loss of non-LHC physics would be unacceptable [4].

With regard to the time frame of the upgrade, we were asked to aim at rapid implementation, even before Linac4 comes on-line. After some initial considerations this turned out to be technically challenging (acceleration from 50 MeV Linac2 energy to 2.0 GeV) and schedule

*With the implementation of the LHC injector upgrade project, the modifications for injection of the H⁻ beam from Linac4 have recently been added as an additional item.

wise unrealistic (long lead time for equipment design and procurement). Therefore, it is assumed that the 2 GeV upgrade is put in place with Linac4, and that we have to base all our considerations on Linac4 beam parameters.

We have considered intermediate beam energies between 1.4 GeV and 2.0 GeV. If we would have found that slightly lower beam energy than 2.0 GeV would have resulted in significant cost savings, and would have in particular avoided changing the Main Power Supply (MPS), such a scenario could have been considered a viable option. However, we found that the present MPS cannot run at any higher energy than 1.4 GeV and needs therefore to be replaced in any possible scenario.

EXPECTED PERFORMANCE GAIN WITH 2 GEV

There is a general consensus that increasing the beam energy will facilitate injection of high intensity beams into the PS. The gain can be quantified by looking at the formulas for the space-charge induced tune spread [5]

$$\Delta Q_x = \frac{R_p N_b}{2\pi^{3/2} \gamma^3 \beta^2 \sigma_z} \oint \frac{\beta_x(s) ds}{\sigma_x(s) [\sigma_x(s) + \sigma_y(s)]} \quad (1)$$

and

$$\Delta Q_y = \frac{R_p N_b}{2\pi^{3/2} \gamma^3 \beta^2 \sigma_z \sqrt{\epsilon_y}} \oint \frac{\beta_y(s) ds}{\sigma_x(s) + \sigma_y(s)} \quad (2)$$

Injection at 2 GeV lowers the space charge effect by a factor $(\beta\gamma^2)_{2\text{GeV}}/(\beta\gamma^2)_{1.4\text{GeV}} = 1.63$. That is, keeping the same space charge tune spread as present, about 65% more intensity could be injected. Equations (1) and (2) contain also terms $1/\sigma_z$, which means that keeping the longitudinal emittance at the present values the bunch length would decrease which would limit the above quoted gain to about 40%. However, as the PS bucket size will increase at 2 GeV, it is believed that one can allow for larger longitudinal emittance and thus compensate for this effect. Another knob to further increase the injected intensity would be to accept a larger transverse emittance, but recent requests from the LHC for low-emittance beams led us to discarding this option.

In summary, from theoretical arguments the gain in injected intensity is expected to be at least 65%.

IMPACT OF ENERGY INCREASE ON BOOSTER EQUIPMENT AND SYSTEMS

Magnets

The natural first question to be asked is if the Booster main magnets can achieve the field levels required for operation at 2 GeV. However, the magnets have been sufficiently over designed such that this is not an issue. A concern was however whether mechanical stress would become an issue when pulsing the magnets permanently with 2 GeV cycles. In order to address this issue, a stress

test has been performed where a spare magnet has undergone 5000 cycles at a field level corresponding to twice the one at 1.4 GeV. No degradation of the magnet was found [6]. However, some minor mechanical modifications needed to be implemented before going to high field levels.

Another issue was that the saturation of the outer rings increases even more than it is already the case at 1.4 GeV. This issue could be satisfactorily solved by changing the present solid retaining plates by laminated ones.

Furthermore, the present water cooling system is insufficient. The requirements on the magnet cooling depend essentially on the magnetic cycle. It was managed to design a 2 GeV cycle where the r.m.s. current remains within 10% of the present one [7]. By staying within this limit it turns out that only minor modifications to the cooling circuits will be required which can be carried out in situ. A higher r.m.s. current would have necessitated a more severe revision of the magnet cooling, which would have probably required removal of the main magnets from the tunnel.

Apart from the main magnets there are a number of auxiliary magnets to be considered. They are mainly used at injection energy and not considered to be an issue. However the study is to be completed. As for the transfer line to the PS, about 15 to 18 out of the 59 magnets will need to be changed. Before this figure can be confirmed, the optics study of the transfer line needs to be completed, which in turn depends on the re-design of the PS injection region (see below). Furthermore the PS injection bumpers and a number of low-energy correctors and quadrupoles need to be checked.

RF System

The complete renovation of the Booster high level and low level RF is planned in the frame of the consolidation program. On the low-level side this consolidation will include the transverse damper and the RF cables. The main part of the RF consolidation will concern the high-level C02, C04 and C16 systems. Notably the consolidation of the C04 system is mandatory to achieve 2 GeV, while consolidation of the C02 and C16 is not mandatory for the energy increase but required to ensure reliable operation over the next 25 years. It is important to notice that it is a necessary condition for the 2 GeV upgrade that the mandatory items of the RF consolidation program are completed within the time frame of the upgrade project.

Beam Intercepting Devices

The Booster dump has been subject to investigations since the question came up whether it would support beam intensities expected with Linac4. The option to dump these beam intensities at an energy of 2 GeV came then as an additional constraint. It became clear that the present Booster dump needs to be replaced by one adapted to the expected beam parameters, and that a spare dump is needed. This activity is covered by the consolidation project and is well under way. Removal of

the existing dump is being planned with participation of RP.

A second intercepting device which potentially needs replacement is the beam stopper BT.STP10. It remains to be confirmed whether it can operate at 2 GeV beam energy. If this is not the case, a new design and production of two units will be required. This has tentatively been allocated in the consolidation program.

Power Converters

The biggest impact of a 2 GeV upgrade would be for the power converters, notably the Booster Main Power Supply. The present Booster MPS can neither deliver the r.m.s. nor the peak current required for 2 GeV operation. The present 1.4 GeV is a hard limit, and the present MPS cannot pulse at any higher value than that.

Increasing the peak power using traditional thyristor technology would have an unacceptable effect on the whole Meyrin network. Therefore, it is proposed to replace the MPS by a POPS-type [8] power supply using a capacitor bank (Figure 1). The available voltage increases and would allow for faster ramping, thus reducing the r.m.s. current. The capacitor bank totally absorbs the peak power. This would at the same time allow dividing the machine into two circuits (inner and outer rings) thus making the trim power supplies used for rings 1 and 4 obsolete. The new main power supply would require a new building for which a location has already been identified. Apart from the MPS a number of smaller power supplies cannot operate at 2 GeV and need to be replaced.

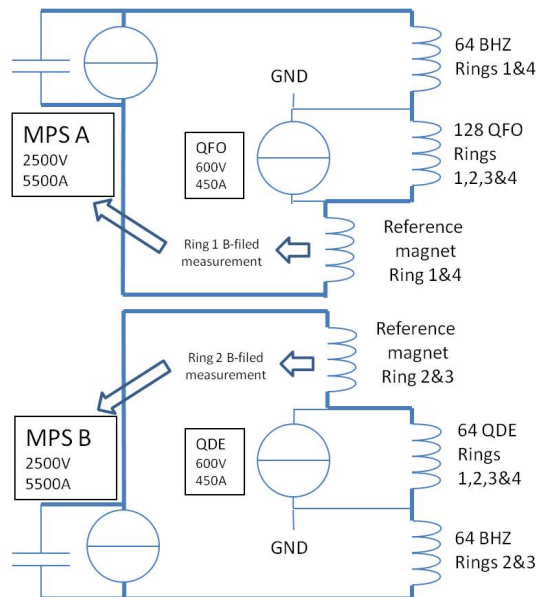

Figure 1: Lay-out of new POPS-type main power supply.

Extraction, Transfer and PS Injection

A number of extraction elements can operate at 2 GeV without modifications. However, notably the extraction kickers (BE.KFA) and recombination septa (BT.SMV) need to be re-designed and re-built. Some other elements,

like the extraction septum BE.SMH, would require modification (re-inforcement of the cooling).

A critical issue is the PS injection septum. The septum would need to be replaced by a longer one for 2 GeV injection, which in turn requires the whole PS injection region to be re-designed. This work is presently in progress. It is hoped that a solution can be found where the injection point remains in PS straight section 42 (SS42) as presently the case. Otherwise it could be moved to SS41, but at the expense of re-designing the BTP line. At the moment work is in progress and a conclusion is expected for early 2011. The PS injection kickers have been confirmed to work at 2 GeV if operated in short-circuit mode. This will result in a small, but acceptable emittance growth.

Electrical Systems

The present power consumption of the Booster is around 10 MVA. The main consumers of electrical power are the power converters and the cooling and ventilation systems. As for the power converters, an increased request of about 100% is expected for the transfer line power supplies, which will be compensated by a 25% decrease estimated for the new MPS. For the cooling and ventilation systems, the required electrical power will be 15-20% above the present one. There is no more power available from the transformers for general services, and the 18 kV “cubicles” cannot be extended. Furthermore the whole electrical system on the Meyrin site needs consolidation. A re-design has started, which includes the increased power needs of a 2 GeV Booster in the frame of a global re-design of the electrical network on the Meyrin site.

Cooling and Ventilation

As for the electrical network, the future design of the cooling system will depend on the needs, mainly the ones of magnets, power converters and RF. A survey of the different work packages has so far not revealed any increase in cooling needs. Therefore, a refurbishment of the cooling station and some distribution piping is considered sufficient.

As for ventilation, no specific needs have been identified. Therefore a complete refurbishment of the existing plant, while keeping the same functionalities, is planned. However, new buildings (e.g. the one for the new MPS) need to be included. Furthermore RP aspects need to be considered when the ventilation system is refurbished.

Other Work Packages

We have investigated the impact on other, smaller work packages with the same care as for the high-impact ones described in more detail above. We have not found any unmanageable items, but derived a number of actions and cost items which went into our general budget and time estimate.

The work package “Booster Injection” will be transferred from the Lianc4 project to the Booster upgrade project including the associated budget.

RESOURCES AND TIME LINES

The resources in terms of budget and manpower have been detailed and published in [3]. We have disentangled the cost of consolidation, i.e. of keeping the Booster operational for the next 25 years but without energy upgrade, and the additional cost of upgrading the machine for 2 GeV operation.

The time lines of the upgrade project are constrained by the long LHC shutdowns. When drafting our planning we have assumed long LHC stops in 2012 and 2016, and come up with a planning that aims at commissioning of the 2 GeV Booster and the Linac4 injection simultaneously in 2016 (Figure 2). Recent discussions

have suggested to install and commission the H⁻ injection first, and commission the 2 GeV upgrade during the following long LHC shutdown. Such a planning can also be envisaged and would have the advantage to spread out the workload rather than concentrating all activities in one shutdown.

It is a common comment with regard to all possible installation and commissioning schedules that the timelines can only be respected if the resources laid out in [3] are made available entirely and at the time when they are needed.

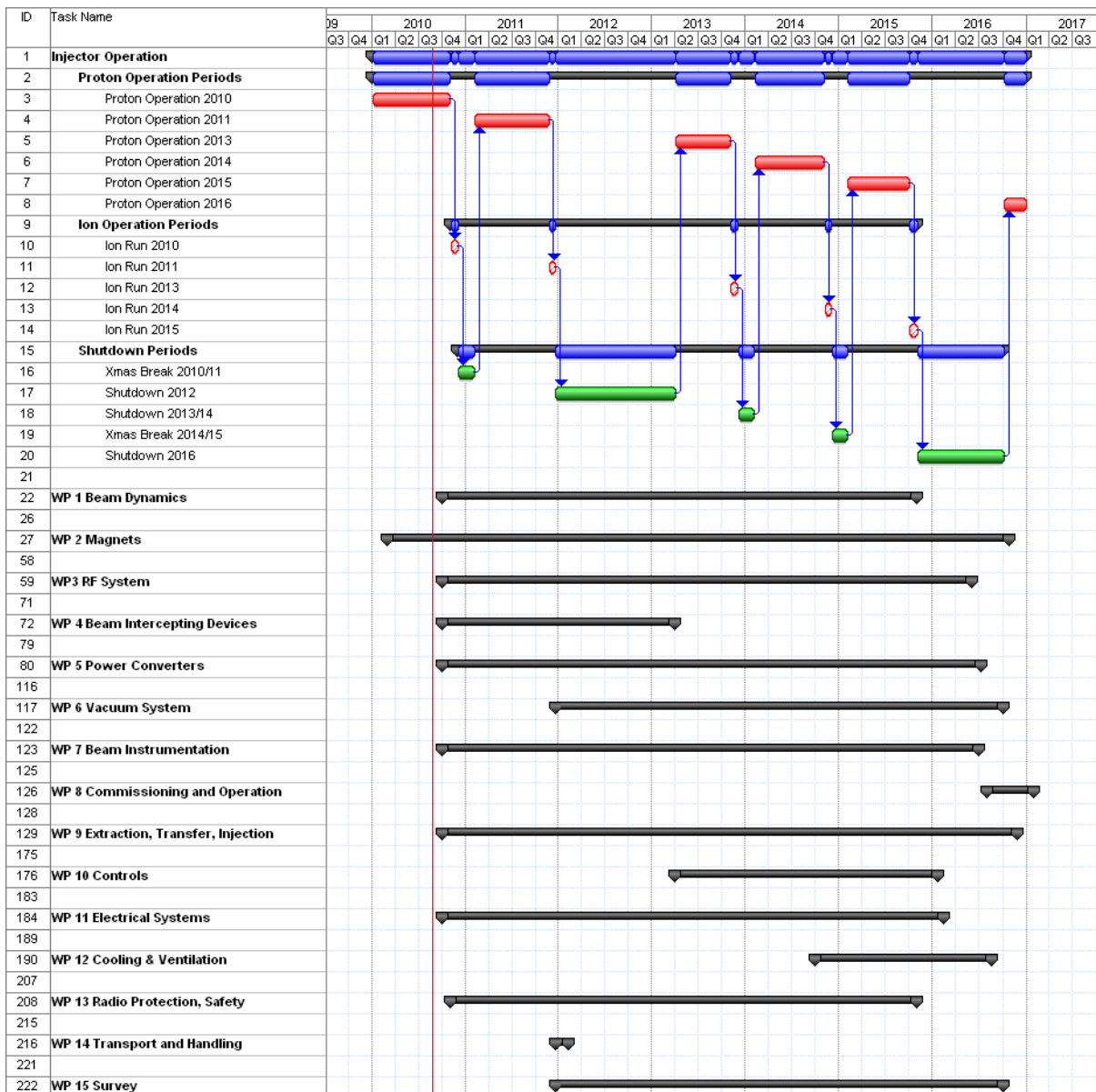

Figure 2: Tentative project planning based on long LHC shutdowns in 2012 and 2016.

REFERENCES

- [1] Proceedings of the Chamonix 2010 workshop on LHC performance, CERN-ATS-2010-026, (2010).
- [2] G. Arduini et al., "Possible Improvements to the Existing Pre-Injector Complex in the Framework of Continued Consolidation", Proceedings of the Chamonix 2010 workshop on LHC performance, CERN-ATS-2010-026, p. 228 (2010).
- [3] K. Hanke et al., "PS Booster Energy Upgrade, Feasibility Study, First Report", <https://edms.cern.ch/document/1082646/3>
- [4] B. Mikulec, "Estimation of Loss for Physics with Idle Cycles during Filling of the LHC with 2 GeV LHC Cycles from the PSB", <https://edms.cern.ch/document/1079117/1>.
- [5] G. Rumolo, LIU day, <http://indico.cern.ch/conferenceDisplay.py?confId=112934>
- [6] A. Newborough, "Magnet tests in SM18", minutes of the Booster Upgrade Working Group 16 September 2010, <https://twiki.cern.ch/twiki/bin/view/PSBUpgrade/MinutesMeeting16September2010>
- [7] A. Blas, "Automatic Magnetic Cycle Editor for the CERN PSB", CERN BE Note in preparation.
- [8] J-P. Burnet, "Progress with POPS", IEFC Workshop 2010, <http://indico.cern.ch/conferenceOtherViews.py?view=standard&confId=70866>