



CM-P00064364

EUROPEAN ORGANIZATION FOR NUCLEAR RESEARCH

Mr. Georges DOME

F-7

CERN-SPS/80-06/ABT

HIGH POWER PULSE GENERATORS FOR FAST PULSED MAGNETS

DEVELOPMENTS AND OPERATIONAL EXPERIENCE

by

H. Kuhn and G.H. Schröder

SUMMARY

The paper describes in its first part the design of a prototype pulse generator for the new inflector of the CERN SPS. After a short explanation of the future SPS injection scheme, the electrical and mechanical design is treated in detail. The generator, equipped with 3 double ended ceramic thyratrons, is designed for a short pulse rise time and low pulse to pulse jitter.

The paper presents furthermore the developments and the operational experience with 4 fast pulsed magnet systems, which contain 29 high voltage thyratrons and 48 ignitrons and which are since 1976 in continuous operation in the SPS. The pulse modulators of these systems generate quasi rectangular pulses of up to 10 kA, 30 kV amplitudes and up to 25 μ s duration with a pulse repetition time of 1 to 10 s. The power switches are double ended ceramic thyratrons, some of which are by-passed by 3 ignitrons in series.

Paper presented
at the 14th Pulse Power Modulator Symposium
Orlando, Florida, June 3-5, 1980

Geneva - 11 June 1980

1. Introduction

The European Organisation for Nuclear Research (CERN) operates since 1976 a Proton Synchrotron of a maximum energy of 400 GeV (SPS) located on the franco-swiss border near Geneva. The circular accelerator with a circumference of about 7 km is housed in a tunnel which is built in the stable rock down to 60 m underground. The accelerator is equipped with 4 different fast pulsed magnet systems for the deflection of the proton beam during one revolution of 23 μ s or part of it. They are used for :

- injection of the beam from a preaccelerator at an energy of 10 GeV
- fast extraction of the accelerated beam at energies between 200 and 400 GeV for beam transfer towards the experimental areas
- internal beam dumping onto an absorber block in case of equipment failure or operation faults
- the measurement of the betatron tunes of the machine.

A fast pulsed magnet system consists typically of :

- line type pulse generators supplying quasi rectangular current pulses of up to 10 kA amplitude and up to 25 μ s duration and located in a surface building
- coaxial transmission lines of up to 300 m length connecting the generator to the ferrite magnets located in the underground tunnel
- ferrite magnets, built as lumped parameter delay lines and working in ultra high vacuum
- termination resistors matched to the characteristic impedance of generator, transmission line and magnet and absorbing the pulse energy of up to 7.5 kJ supplied by the generator.

The systems used in the SPS have been presented at the 12th Modulator Symposium in 1976.¹

2. Prototype of a Line-type Pulse Generator for the New SPS Proton Inflector

2.1 Purpose

At present, the SPS accelerates about once every 10 s more than 2.10^{13} protons which are shared between about 15 physics experiments. There is a need to increase this intensity and the SPS intensity improvement program established in 1977, foresees to bring the intensity to more than 3.10^{13} protons per pulse, mainly by extending the rf system and modifying the injection scheme.² This requires, amongst other modifications, the construction of a faster and more powerful SPS inflector.

The presently used injection scheme is shown schematically in Fig. 1.

The protons are injected with a momentum of 10 GeV/c from an injection synchrotron (CPS), the diameter of which is 11 times smaller than that of the SPS. The operation of the SPS started with extraction of the beam from the CPS during 10 CPS revolutions, filling in this way 10/11th of the SPS and leaving 1/11th (2.1 μ s) to allow the magnetic field in the inflector magnet to fall to zero before the circulating protons arrive again after their first revolution.

To increase the intensity of the SPS, the CPS can accelerate repeatedly protons which are extracted in batches of shorter duration and placed successively around the circumference of the SPS. They are held circulating at injection energy until the SPS ring is filled and their common acceleration can start. For the moment, two proton batches with a duration of 10.5 μ s are injected. The presently installed inflector has a rise and fall time of the magnetic field of 0.75 μ s which permits even 3-batch injection.

The SPS intensity improvement project foresees the injection of up to 5 proton batches and an accelerated intensity of at least $3 \cdot 10^{13}$ protons per pulse. In addition, the future part-time use of the SPS as a proton - antiproton collider at 270 GeV/c calls for the injection of up to 6 short proton bunches at 26 GeV/c.

The rise and fall times of the magnetic field of the presently installed inflector are too long to allow 5-batch injection and the deflection strength is insufficient for the injection of protons at 26 GeV/c. A new fast inflector is therefore under construction allowing the injection of 2 to 5 proton batches from the CPS.

The following chapters describe the design and the performances of a prototype system.

2.2 Design Principle

A fast pulsed magnet system must meet two requirements which are contradictory, i.e. a high deflection strength and a short rise time of the magnetic field. Both properties are, for a given operational voltage, proportional to the product of the electric current passing through the magnet and its length.

In order to meet the contradictory requirements, the length must be reduced by splitting the magnet system into several independently powered modules. The new inflector requires 12 magnet modules which are connected in pairs to 6 pulse generators. A block diagram of one fast pulsed magnet circuit is shown in Fig. 2.

A power supply charges the pulse forming network (pfn) to a maximum voltage of 60 kV. Then the pfn is discharged by fast electronic switches through matched transmission lines into the magnet modules which are terminated by matched resistors.

Three switches are necessary in order to get a fast rise and fall time and an adjustable pulse duration :³

- a main switch to initiate the discharge
- a clipper switch to shorten the fall time
- a dump switch to change the pulse length and to allow the absorption of the tail of the pulse in the dump resistor.

A transmission line of 180 m length connects the generators, housed in a building at surface level, to the magnets in the accelerator tunnel. Each line consists of several coaxial cables, type RG 220/U, with a characteristic impedance of 50 Ohm, connected in parallel.

Each fast pulsed magnet has an equivalent circuit in the form of a lumped parameter delay line with a characteristic impedance of twice that of the pfn. The pulse travels therefore through the magnet without major deformation and is absorbed in the terminating resistor.

To meet the requirements of the different injection schemes, the generator must have a pulse duration of up to 10.5 μ s to allow 2-batch injection. For 5-batch injection a pulse duration of only 4.2 μ s is required. For the purpose of testing the thyratrons the prototype has been designed for a pulse duration of 24 μ s.

The kick rise time is determined by the distance between adjacent batches, whereas the kick fall time is given by the duration of the large gap between batch 5 and batch 1. Originally, the duration of the large gap was fixed to 1.5 μ s, leaving 0.15 μ s as distance between adjacent batches. The kick rise time was therefore chosen to be 0.10 μ s. In the meantime, the large gap has been shortened and the distance between adjacent batches increased as shown in Fig. 1.

The main parameters of the prototype inflector are listed in Table 1:⁴

Table 1
Main System Parameters

Maximum generator voltage	60 kV
Characteristic impedance	8.33 Ohm
Current amplitude	3.6 kA
Pulse duration	0.5 μ s to 24 μ s
Generator rise time	40 ns
Generator fall time	380 ns
Magnet filling time	70 ns
Kick rise time (2 to 98%)	100 ns
Kick fall time (98 to 2%)	400 ns
Flat top ripple	< \pm 1%
Pulse repetition time	5 pulses, 0.6 s apart within 12 s

2.3 Pulse Forming Network

2.3.1 Design Philosophy: Experience gained in recent years in the operation of high power pulse forming networks equipped with 3 independently triggered thyatron switches has shown that careful screening of the switches is necessary to avoid erratic firings of the 2nd and 3rd switch caused by electromagnetic pickup from the 1st switch.

Prototype test started in 1972 with all 3 switches housed in one common tank.⁵ Because of interference between the switches this design was abandoned in favour of a separate housing for the dump switch. Main and clipper switches, which have a common anode connection, remained however in the same tank. Both switch tanks were then connected via short cables to the pfn tank. This type of generator is operating in the SPS (Fig.3).¹

Nevertheless, special measures, described in chapter 3.2 had to be taken to avoid the clipper switch being triggered by the discharge of the main switch, especially for generators with a short rise time.

For the design of the new inflector whose rise time is particularly short, it appeared therefore imperative to house all three switches in separate tanks. To avoid stray inductances between the pfn and the switches, the latter are mounted directly on top of the pfn (Fig.4).

The physical separation between the common anode connection of main and clipper switches introduces however a stray inductance which increases either the rise or the fall time of the pulse depending on the position of the front matching cell of the pfn. This stray inductance has been minimized by connecting a stripline which is matched to the characteristic impedance of the pfn between the anodes of main and clipper switches. This stripline is housed in the pfn. At both ends of the stripline, front matching cells for rise time improvement are added.

The lowest ripple on the flat top of the current pulse is obtained when the cells of the pfn are aligned in one row. This arrangement is however inconvenient for the construction of the pfn tank. Experience with the existing pfn's has shown that a serpentine arrangement of the cells, which is more suitable for the tank construction has two major drawbacks :¹

- The ripple is relatively high because of a change in the mutual inductance between the cells at the position of the bends.
- The ripple changes when the pulse length is varied. This is due to electro-magnetic interference between two adjacent rows and is overcome by screening the coils.

In order to avoid these drawbacks the following layout has been chosen as illustrated in Fig. 5.

- The cells are aligned in only 2 1/2 rows as compared to 5 rows for the old inflector.
- The first 8 cells are arranged in a straight line in order not to perturb the beginning of the pulse which is particularly sensitive to mismatch.
- The 2 full rows are located near the tank borders in order to keep them separated.
- The coil diameter is rather small in order to confine better the strayfield.
- The connections to the 3 switches as well as the stripline are mounted along the central axis between the rows of cells.
- The 8 last cells on the axis are discharged at the end of the pulse and are therefore less sensitive to interference from the other rows.

The equivalent circuit of the pulse generator is given in Fig. 6.

2.3.2 Rise Time: The rise time of the current pulse is mainly determined by the characteristic impedance of the pulse generator, the unmatched stray inductance of the main thyatron and its plasma formation time.

The unmatched stray inductance L_{th} of the main thyatron is estimated to be about 140 nH, giving a rise time contribution of about 25 ns.

The plasma formation time of the thyatron becomes shorter for a higher gas pressure in the tube. High gas pressure increases however the likelihood of premature firings. To obtain a reliable operation at high gas pressure, the generator is charged via a resonant charging power supply which supplies voltage to the thyatron only a few milliseconds before its turn on.⁶ Erratic firing is thus strongly reduced even at high gas pressure, because of the short time that the thyatron has to withstand high voltage.

The contribution of the stray inductance of the front matching cell to the pulse rise time is small, because the stripline as part of the front matching cell has a very small stray inductance. The parameters of the two front matching cells at both ends of the stripline have been adjusted empirically.

The rising edge of the pulse at a reservoir voltage of 6 V is shown in Fig. 7.

2.3.3 Fall Time: The fall time of the current pulse is, in first instance, determined by the stray inductances in the branches of the clipper switch and the main switch and by the characteristic impedance of the pfn.

Due to the introduction of the matched stripline between main and clipper switches, the total stray inductance in the branch of the main switch could be kept small, resulting in a fall time of the current pulse of about 400 ns. Fig. 8 gives an oscillogram of the fall time.

2.3.4 Flat Top Ripple: As a result of the comparably large number of 39 pfn cells and their arrangement in only 2 1/2 straight lines with few bends, a flat top ripple of less than $\pm 1\%$ is obtained as shown in Fig.9. The pulsed magnet field of about 12 μs duration as required for 2-batch injection is given in Fig. 10.

2.3.5 Construction: The 39 regular cells of the pfn are composed of capacitors of 40 nF and solenoids of 2.78 μH . The capacitors, made by LCC (France) have an insulating outer case of cylindrical shape with a length of 628 mm and a diameter of 172 mm.

The dielectric is a paper mylar mixture impregnated in mineral oil and designed for an operation voltage of 65 kV.

The capacitors are mounted in cylindrical stainless steel pots of 583 mm length and 180 mm diameter, which are fixed vertically into the base plate of the pfn tank. This type of construction provides a low inductance coaxial return path and minimises the quantity of silicon fluid required for insulation. The use of mineral oil is excluded because of fire hazards.

The inductor solenoids are copper spirals of 60 mm diameter and an adjustable length of about 200 mm. They are mounted horizontally between the h.t. electrodes of the capacitors as shown in Fig. 5.

2.4 Switches

2.4.1 Choice of Switch Type: CERN has excellent operational experience with the deuterium filled, three gap, double ended thyatron with a ceramic envelope, type CX1171B, manufactured by English Electric Valve Company (EEV), for the switching of current pulses of up to 10 kA and a duration of up to 25 μs . The tube is electrically symmetrical, with identical cathode and grid assemblies at both ends. The choice of this thyatron as switch for the new SPS inflector was therefore rather obvious.

The parallel connection of ignitrons, as in previous switches¹ was however avoided since this would have complicated considerably the switch construction. To obtain a fast rising pulse, the ignitron anode should be connected directly to the pfn and hence be at the bottom of the switch whereas the cathode should be near the top. This position is however not possible because of the liquid mercury cathode of the ignitrons.

Nevertheless, the switch has been tested with a pulse duration of 25 μs in order to repeat in more detail earlier test on the switching behaviour of the thyatrons for pulses of long duration.

2.4.2 Electrical Design: The electrical circuit of the thyatron is shown in Fig. 11. The voltage divider which provides the potentials for the gradient grids is mounted around the thyatron. Each of the three resistors of 10 MegOhm is made up of 36 agglomerated carbon resistors in series and compensated by ceramic capacitors of 500 pF and 30 kV.

It was found experimentally at English Electric Valve Co and at CERN that the voltage holding and hence the lifetime of the thyatron may be substantially improved, if the value of the two resistors which connect the gradient grids to the potential divider is increased from 47 Ohm to 470 Ohm.

2.4.3 Jitter: A large effort has been made to decrease the variation of the pulse to pulse anode delay (jitter). Measurements have been executed on a heated thyatron by observing the moment of breakdown of the trigger pulse on the control grid 2. This corresponds almost to the anode jitter and avoids to apply high voltage to the thyatron which facilitates experimentation.

It was found, that the jitter is independent of the voltage and the rise time of the trigger pulse, provided that the former is above 500 V, and the latter shorter than the anode delay time. The jitter became almost zero when the trigger pulse was synchronised with the mains, an indication that mains ripple is at the origin of the jitter.

Improved filtering of the dc supply to control grid 1 and stabilisation of the grid 1 current by means of constant current diodes brought a substantial improvement. Adding furthermore a filter capacitor to control grid 2 and splitting the trigger pulse via an R-C network between the control grids 1 and 2, resulted in a jitter of less than 2 ns. The improved cathode supply circuit is shown in Fig. 12. Jitter measurements at an anode voltage of 60 kV confirmed the results as given in Fig. 7.

2.5 Operational Results

The pulse generator has been operated at a charging voltage of 60 kV corresponding to a current of 3.6 kA and a peak power of 108 MW. The pulselength was adjusted to 25 μ s. The power supply was pulsed with a train of 5 pulses at 0.5 s interval followed by a rest period of 2.5 s. The reservoir voltage was initially set to 5.6 V and after 10^5 pulses increased to 6.0 V.

The main thyatron, which was still equipped with decoupling resistors in the gradient grid circuits of 47 Ohm, started to show signs of deterioration after $8 \cdot 10^5$ pulses. The rate of erratic firing became about 1 in 100 pulses. These results confirmed earlier tests carried out in 1973.⁵

A new thyatron was then installed and the pulse duration reduced to 17 μ s. It performed perfect at reservoir voltages of up to 6.1 V. The lifetime was stopped after 10^7 pulses at 60 kV. The rate of erratic firings was less than 1 in 10^5 pulses, which is our limit of detection. At the end of this test the jitter was still less than 2 ns. This second thyatron was equipped with decoupling resistors on the gradient grids of 470 Ohm, which may be, besides the reduction in pulse duration, a reason of its better performance.

3. Operational Experience with Thyratrons and Ignitrons

3.1 General

Since May 1975, a total of 29 high power switches are in operation in the four different fast pulses magnet systems around the SPS machine. Six of them are EEV thyratrons type CX 1154 B, 7 are of type CX 1171 B and 16 are "Thyragnitron" systems using a thyatron CX 1171 B bypassed by 3 EEV ignitrons type 7703 in series. Each system has conducted about 10^7 pulses and has operated about 30 000 hours. During this period of 5 years 20 thyratrons type CX 1171 B have been replaced after in general more than 12 000 filament hours, mainly because of insufficient voltage holding. Among the 29 thyratrons actually in service, 7 operate since more than 10 000 h and 9 since more than 20 000 h.

3.2 The "Thyragnitron" Switch

Because of the fast rising anode voltage during resonant charging of the pfn, the potential dividers of the ignitrons and the thyratrons are dynamically compensated by ceramic capacitors of 500 pF per gap and rated for 30 kV. During the first year of operation, several of the compensating capacitors in the ignitron chain failed despite their large overvoltage protection factor, destroying at the same time the glass structure of the anodes of the ignitrons.

This failure could be explained as follows. If one of the ignitrons fires erratically prior to the thyatron, the full charging voltage is still applied to the ignitron chain. A second ignitron starts then conduction because its anode voltage is suddenly increased.

The third one in the chain and hence its parallel capacitor gets the full charging voltage which destroys the capacitor. Therefore two 1000 pF capacitors in series, each with a rated voltage of 30 kV have been installed on each ignitron. This has cured the fault. Fig. 13 and 14 show the ignitron chain with its compensating capacitors before and after assembly.

Some other rare failures in the "Thyragnitron" switches were caused by the ignitrons failing to fire so that the thyatron had to conduct the total pulse and was destroyed (see also chapter 3.3).

The life expectancy for ignitrons is of the same order of magnitude as for thyratrons. Apart from the capacitor faults described above, at some rare occasions ignitrons failed to fire because the ohmic resistance between ignitor and cathode had strongly decreased.

3.3 The Screened Grid Thyatron

The pulse generators presently in operation at the SPS have a common tank for the main and the clipper switches in order to keep the inductance between both switches low. As already mentioned in chapter 2.3.1, the clipper switch has the tendency to turn-on pre-

turely with the discharges of the main switch so that the current pulse is shortcircuited.

One of the causes for the malfunctioning is the capacitance between the anode and the control grid 2 of the clipper switch which transmits the negative jump of the clipper anode at the trigger instant of the main switch to the clipper control grid. This causes oscillations of the clipper control grid, which can turn-on the switch.

To cure this effect, a capacitor of 500 pF in series with a resistor of 50 Ohm has been branched between control grid 2 and cathode of the thyatron. This decreases the amplitude of the oscillations without too much attenuating the trigger pulse. It does however not completely cure the problem. As the grid oscillation on the clipper depends strongly on the rate of rise of the current in the main switch, the reservoir voltage of the latter has also to be decreased in order to diminish the rate of rise of the pulse. In some cases, the reservoir voltage of the clipper has to be lowered in addition. These measures tend however to reduce the lifetime of the thyatron and can not be considered as a long term solution.

In order to solve the problem, EEV developed a thyatron with an additional screening grid on the anode side of control grid 2. The grid is connected to cathode potential and shortcircuits the capacitive currents coming from the anode before they can reach the control grids. This thyatron has the type designation CX 1171 C. It has the same outer dimensions as the type CX 1171 B and can therefore directly replace the latter.

A prototype has recently been tested in the fast extraction system of the SPS. It was installed in a main-clipper tank without the aforementioned blocking circuit between grid 2 and cathode.

Pulsing the generator with a charging voltage of 60 kV, the reservoir voltage of the main switch had to be raised from the original 4.8 V to 5.8 V before the effect reappeared. At a reservoir voltage of 5.6 V the new type of thyatron performed perfectly. The anode delay time is slightly larger compared to a thyatron of type CX 1171 B which is however of no importance in this application. The new thyatron CX 1171 C has a superior performance from the point of view of pulse voltage hold-off in the clipper position and will be used for all clipper thyatrons in the fast pulse generators of the SPS.

3.4 Limitations of Thyatrons to Switch Pulses of Long Duration

When in 1973 the "Thyragnitron" was chosen as main switch for the SPS kicker magnets, it could not be excluded completely that, for systems with comparably low pulse currents, the switch would also work reliably without bypassing ignitrons. For lack of time and in order to play it safe, ignitrons were installed in all systems working at a charging voltage of 60 kV.⁵ In the meantime, tests without ignitrons have however been pursued. First tests were made in one of the pulse generators of the fast extraction system, which operates at a charging voltage of 60 kV with a current amplitude of 3 kA. The maximum pulse power is 90 MW for 25 μ s. After several months of operation, corresponding to about 10^6 pulses, the thyatrons, not backed up by ignitrons, started to fail.

A second test was made, involuntary, in the beam dumping system which works at a current amplitude of 10 kA and a pulse duration of 25 μ s, corresponding to a pulse power of almost 300 MW. Due to simultaneous faults of the ignitron trigger and the corresponding interlocks, the thyratrons had to conduct the total current. They were damaged already after about 1 000 pulses. A few pulses of 25 μ s duration in this power range may already destroy the thyratron whereas, if it is backed up by ignitrons, the average lifetime of the thyratrons in the beam dumping system is about 8 000 hours.

A third test is already described in chapter 2.5. A thyratron type CX 1171 B failed in switching current pulses of 3.6 kA with a duration of 25 μ s after about 10^6 pulses. When the pulse duration was reduced to 17 μ s another tube switched more than 10^7 pulses.

Furthermore, at the moment 7 thyratrons are under test which switch pulses with a current amplitude of 4.8 kA and a duration of 12 μ s. They work satisfactory.

The two last tests described are carried out with decoupling resistors of 470 Ohm between the voltage divider and the grids (see chapter 2.5), whereas all other tests described were made with resistors of 47 Ohm. Since the exact reasons for the influence of these resistors on the switching behaviour at higher ratings of current and pulse duration is not known, it is intended to continue these tests for higher ratings with the resistors of 470 Ohm.

The limitations of these thyratrons to switch pulses of long duration can not be determined in an exact way, because the field of applications is vast and the number of thyratrons tested is too small to make statistically relevant statements. Nevertheless, the results presented may help system designers to see the possibilities and the limits of these devices.

Conclusion

Double ended ceramic thyratrons bypassed by the series connection of 3 ignitrons have proven in recent years to be reliably operating switches for currents of at least 10 kA and pulse durations of at least 25 μ s, blocking voltages of at least 60 kV and repetition rates of at least 1 pps.

Their operational lifetime spans from about 8 000 h for current amplitudes of 10 kA to more than 15 000 h for pulses of 3 kA.

Thyratrons not being bypassed by ignitrons have switched pulses of 3.6 kA/17 μ s and 4.8 kA/12 μ s more than 10 million times. Current rise times to 3.6 kA within 40 ns and a pulse to pulse jitter as low as 2 ns over 3 h have been obtained.

In conclusion, these fast power switches offer a reliable and in nearly all aspects satisfactory behaviour in the day to day operation of fast kicker magnets installed in a large accelerator complex.

Acknowledgements

The work reported has benefitted from the constant support of W.C. Middelkoop and B. de Raad.

We would like to thank E. Frick for the mechanical design of the pulse generator and J.P.Zanasco, J.Bonthond and H. Verhagen for the construction of the command and interlock electronics.

R. Chappuis carried out the adjustment of the pfn and R. Tröhler participated in the life tests.

Last but not least it is our pleasure to thank H. Menown and R. Snelling of English Electric Valve Co for their close cooperation, especially in the development of the "screen grid" thyatron CX 1171 C.

References

1. P.E. Faugeras, E. Frick, C.G. Harrison, H. Kuhn, V. Rödel, G.H. Schröder, J.P. Zanasco
The SPS Fast Pulsed Magnet Systems
12th Modulator Symposium, New York, 1976
2. M.C. Crowley Milling, B. de Raad
Proposal to increase the Intensity of the SPS
CERN-SPS/AC/77-12
3. P.E. Faugeras
Calculations on the SPS Inflector Magnet and its Pulse Generator
CERN LAB II/BT/72-1
4. H. Kuhn, G.H. Schröder, J.C. Soulié
SPS Infector for Multibatch Injection,
CERN/SPS/ABT/nt/77-1
5. P.E. Faugeras, H. Kuhn, J.P. Zanasco
Generation of High Current, Long Duration Rectangular Pulses
11th Modulator Symposium, New York, 1973
6. G.H. Schröder
Design and Tests of a 5 kJ, 60 kV Resonant Charging Power Supply for the ISR Beam
Dumping System
CERN-ISR-PO/72-22

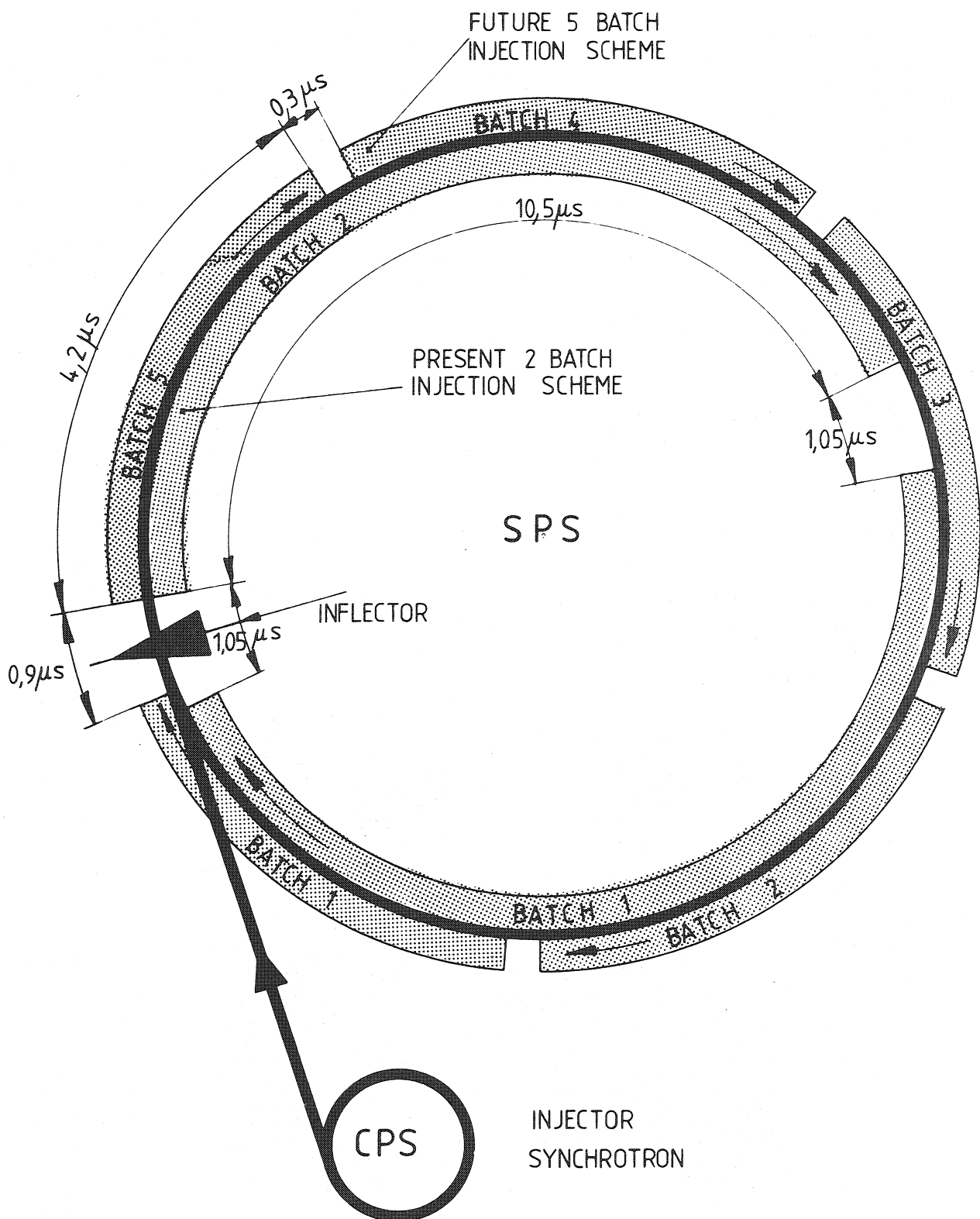

Fig. 1 - Present and future injection schemes of the SPS

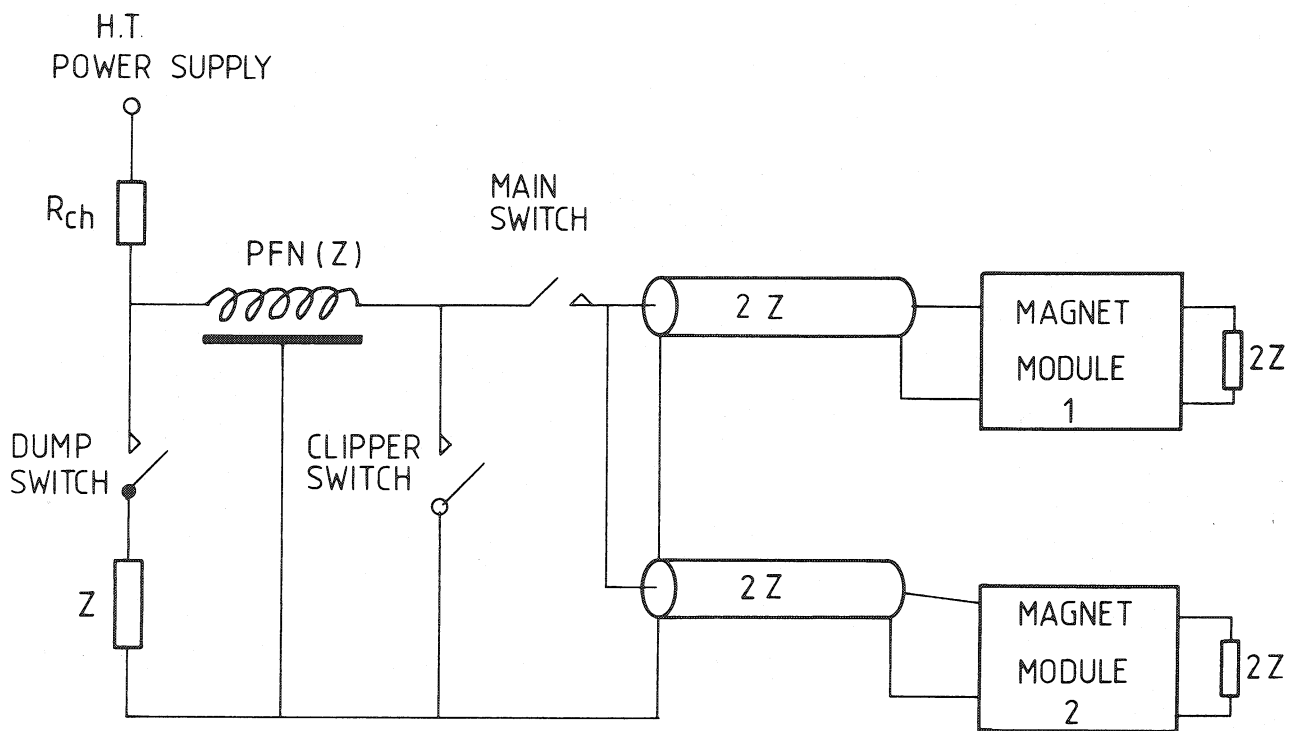

Fig. 2 - Bloc diagram of fast pulsed magnet circuit

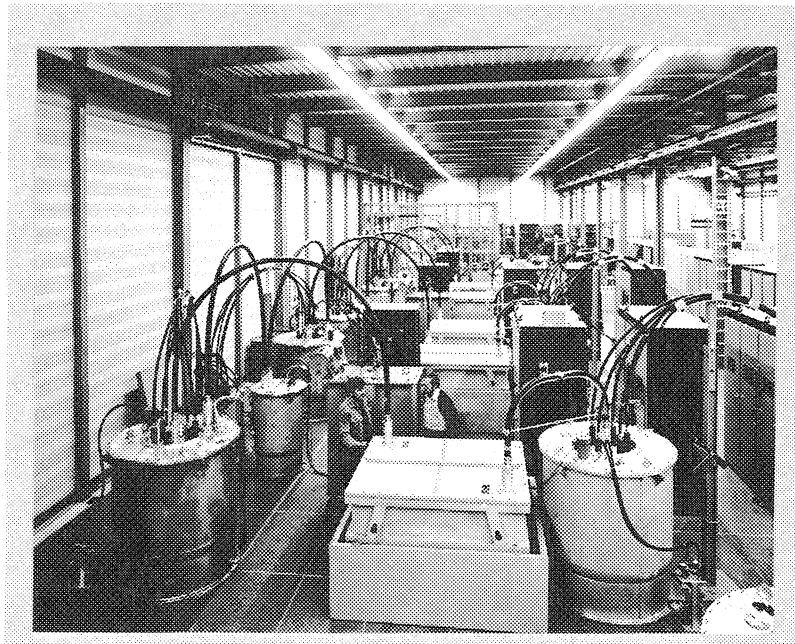

Fig. 3 - Pulse generators of the fast extraction system. The square tanks in the center house the pulse forming networks, the round tanks on the right hand side the main and the clipper switches and the round tank on the left hand side the dump switch.

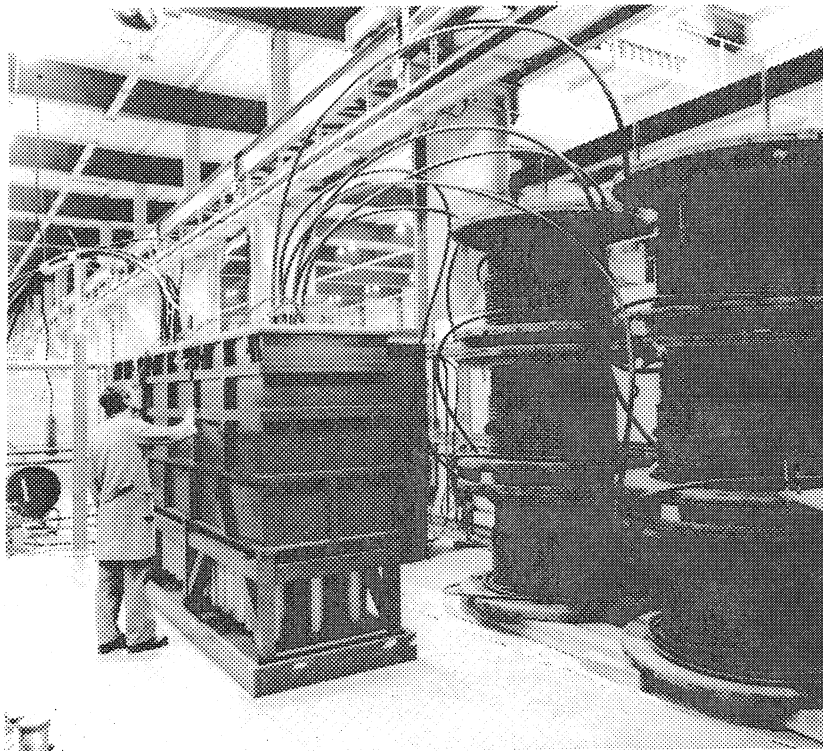

Fig. 4 - Prototype pulse generator of the new SPS inflector. The 3 switches are mounted in separate tanks on top of the pfn. The cylindrical housings of the capacitors are visible under the pfn tank. On the right the transmission line to the magnet, built up of 6 coaxial cables type RG 220/U connected in parallel.

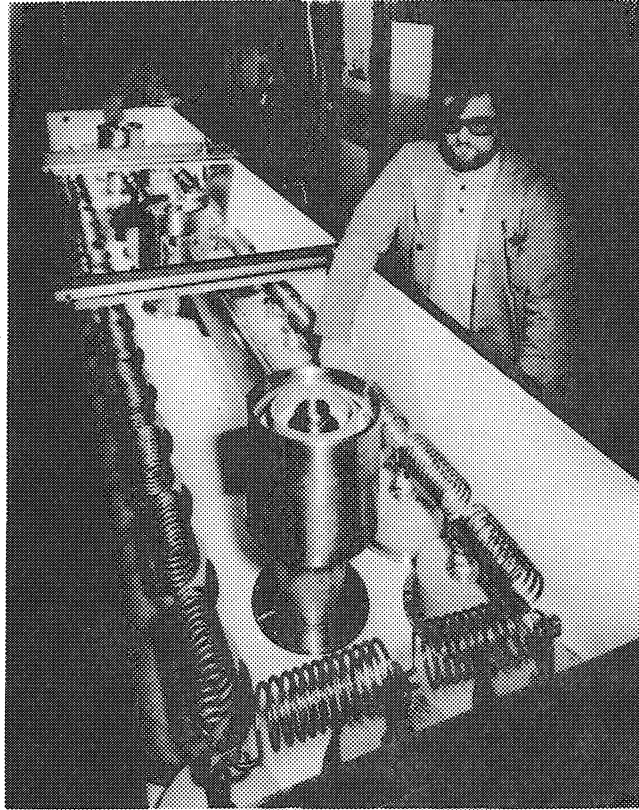
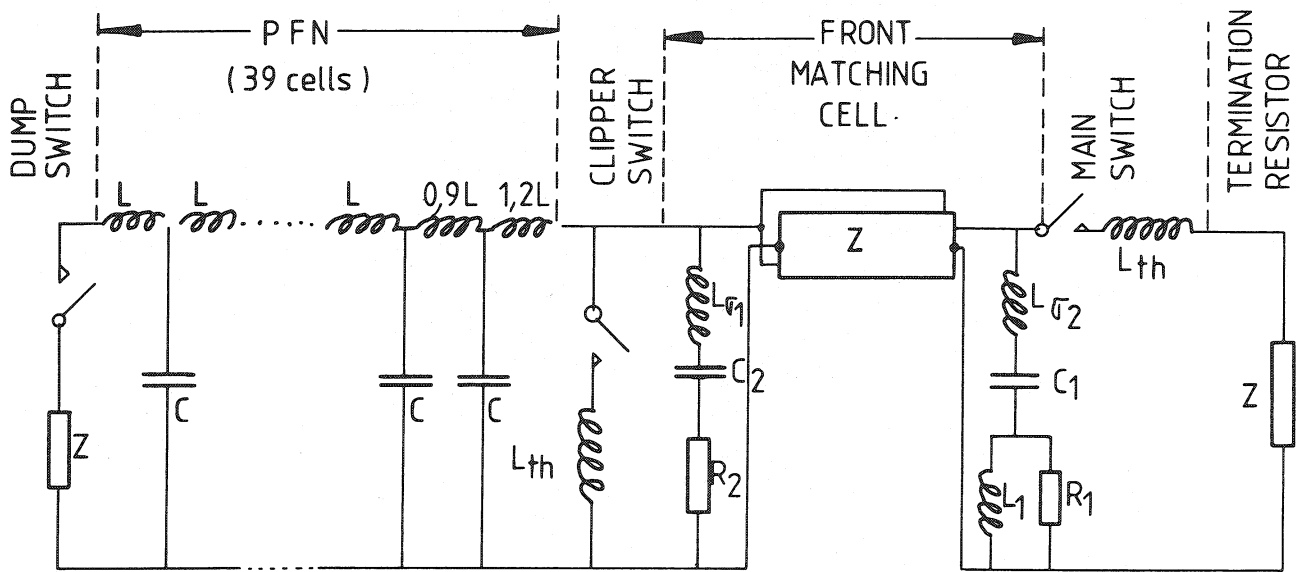

Fig. 5 - View into the tank of the pulse forming network. The LC-ladder network is mounted along the border of the tank. The coaxial connections to the 3 switches and the strip-line are mounted along the central axis.



$Z = 8.33 \Omega$	$R_1 = 11.3 \Omega$	$R_2 = 22 \Omega$
$C = 40 \text{ nF}$	$C_1 = 19.5 \text{ nF}$	$C_2 = 22 \text{ nF}$
$L = 2.78 \mu\text{H}$	$L_1 = 3.7 \mu\text{H}$	

Fig. 6 - Equivalent circuit of the pulse generator

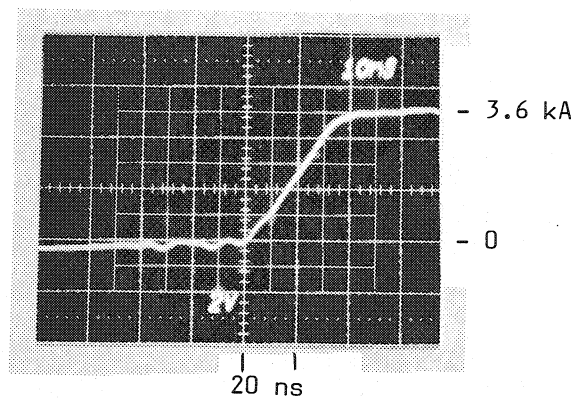

Fig. 7 - Pulse risetime and time jitter measured on one of the two termination resistors. For the jitter measurements, 2 x 5 pulses are superimposed within a time interval of 3 h.

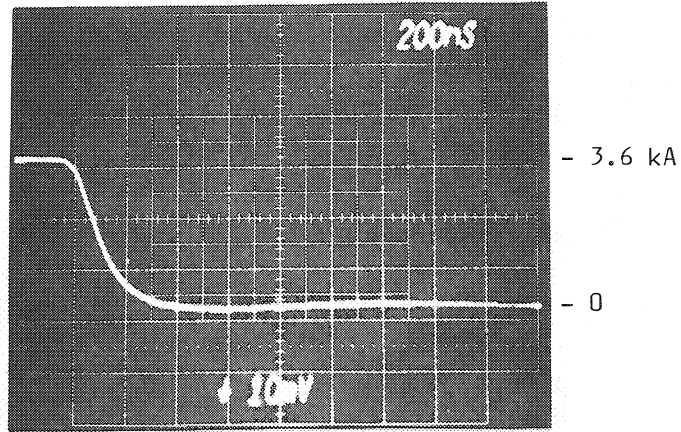

Fig. 8 - Pulse fall time

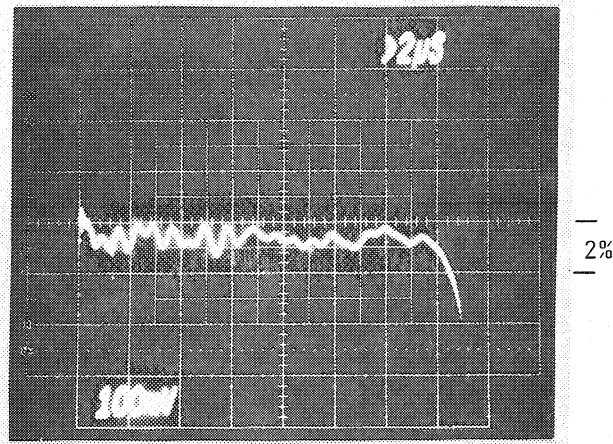

Fig. 9 - Flat top ripple

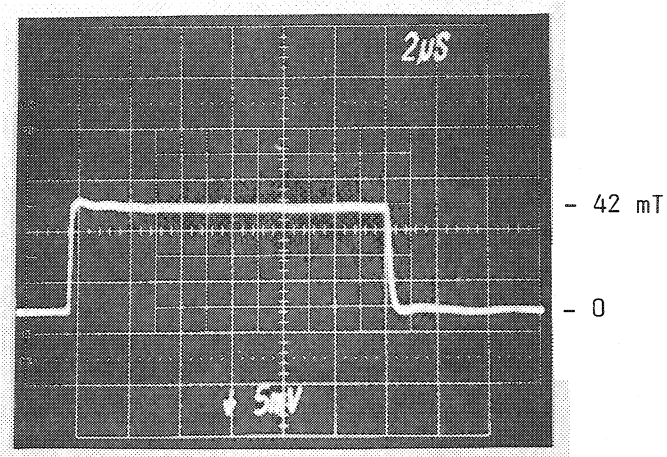

Fig. 10 - Pulse of the magnetic field in the kicker magnet, corresponding to a charging voltage of 60 kV.

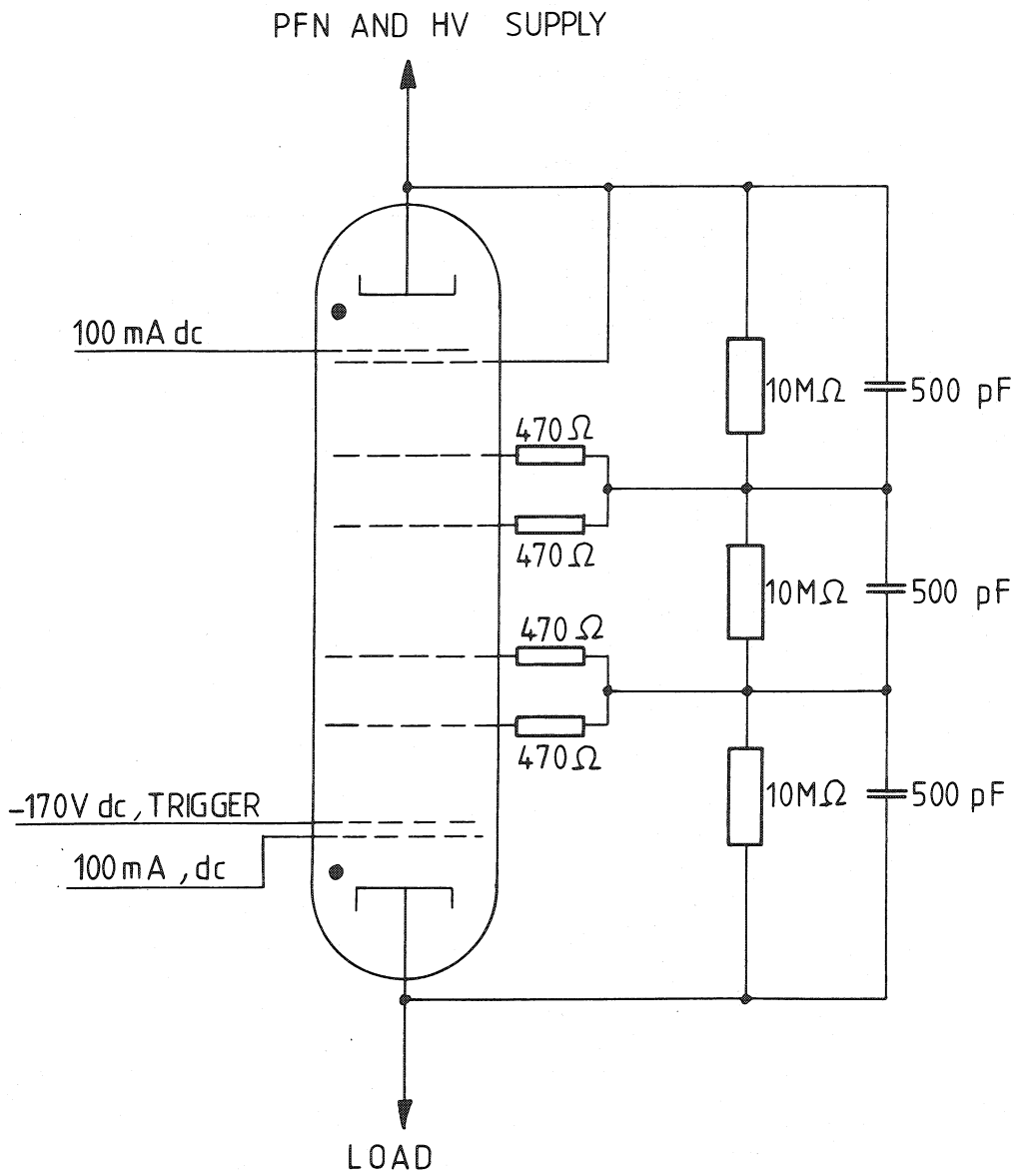

Fig. 11 - Electrical circuit of the double cathode thyatron CX 1171B

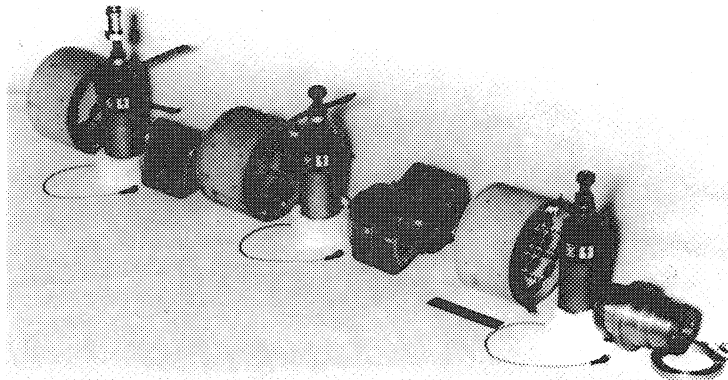

Fig. 13 - Ignitron chain before assembly.

Between the ignitrons type EEV 7703 are the resistive voltage dividers and the ceramic capacitors for frequency compensation.

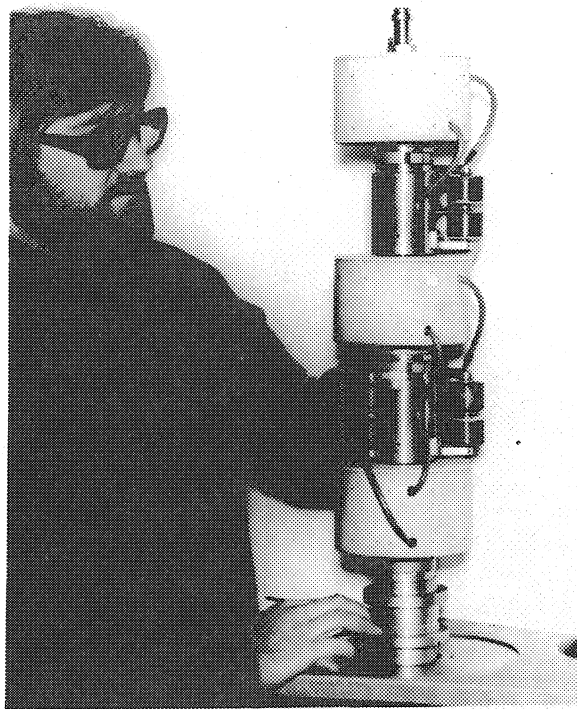

Fig. 14 - Ignitron chain assembled.

The resistors inside the voltage divider pots heat the anodes of the ignitrons, providing a temperature difference between anodes and cathodes which assures a very reliable operation.