

**EUROPEAN ORGANIZATION FOR NUCLEAR RESEARCH  
CERN - ACCELERATORS AND TECHNOLOGY SECTOR**

CERN-ATS-2010-187

**DESIGN OF A 1.42 GHZ SPIN-FLIP CAVITY FOR ANTIHYDROGEN ATOMS**

F. Caspers, S. Federmann, B. Juhasz<sup>1</sup>, E. Mahner, E. Widmann<sup>1</sup>

**Abstract**

The ground state hyperfine transition frequency of hydrogen is known to a very high precision and therefore the measurement of this transition frequency in antihydrogen is offering one of the most accurate tests of CPT symmetry. The ASACUSA collaboration at CERN will run an experiment designed to produce ground state antihydrogen atoms in a cusp trap. These antihydrogen atoms will pass with a low rate in the order of 1 per second through a spin-flip cavity where they get excited depending on their polarization by a 1.42 GHz magnetic field. Due to the small amount of antihydrogen atoms that will be available the requirement of good field homogeneity is imposed in order to obtain an interaction with as many antihydrogen atoms as possible. This leads to a requirement of an RF field deviation of less than  $\pm 10\%$  transverse to the beam direction over a beam aperture with 10 cm diameter. All design aspects of this new spin-flip cavity, including the required field homogeneity and vacuum aspects, are discussed.

<sup>1</sup> Stefan Meyer Institute for Subatomic Physics, Wien, Austria

CERN-ATS-2010-187  
30/05/2010  

Presented at :  
1<sup>st</sup> International Particle Accelerator Conference (IPAC 2010)  
May 23-28, 2010, Kyoto, Japan

Geneva, Switzerland  
May 2010

# Design of a 1.42 GHz Spin-Flip Cavity for Antihydrogen Atoms

S. Federmann, F. Caspers, E. Mahner, CERN, Geneva, Switzerland

B. Juhász, E. Widmann, Stefan Meyer Institute for Subatomic Physics, Wien, Austria

## Abstract

The ground state hyperfine transition frequency of hydrogen is known to a very high precision and therefore the measurement of this transition frequency in antihydrogen is offering one of the most accurate tests of CPT symmetry. The ASACUSA collaboration at CERN will run an experiment designed to produce ground state antihydrogen atoms in a cusp trap. These antihydrogen atoms will pass with a low rate in the order of 1 per second through a spin-flip cavity where they get excited depending on their polarization by a 1.42 GHz magnetic field. Due to the small amount of antihydrogen atoms that will be available the requirement of good field homogeneity is imposed in order to obtain an interaction with as many antihydrogen atoms as possible. This leads to a requirement of an RF field deviation of less than  $\pm 10\%$  transverse to the beam direction over a beam aperture with 10 cm diameter. All design aspects of this new spin-flip cavity, including the required field homogeneity and vacuum aspects, are discussed.

## INTRODUCTION

The comparison of antimatter to matter provides valuable information regarding charge parity time (CPT) violation. At CERN's Antimatter Decelerator (AD) spectroscopic measurements of antiprotons and exotic atoms such as antiprotonic helium have already been successfully conducted [1]. Within the ASACUSA (Atomic Spectroscopy And Collisions Using Slow Antiprotons) collaboration, a new experiment is currently being built aiming to measure the ground state hyperfine splitting (GS-HFS) frequency of antihydrogen ( $\bar{H}$ ) [2]. This splitting is caused by interaction between the proton (antiproton) and electron (positron) spins. The resulting four states ( $F=0$  singlet and  $F=1$  triplet state) can be divided into a pair of low field seekers and high field seekers (Figure 1). The transition between these states has the characteristic frequency of 1.42 GHz (famous 21 cm line of hydrogen). This frequency is proportional to the proton (antiproton) magnetic moment via [2]

$$\nu_{\text{HFS}} = \frac{16}{3} \left( \frac{m_p}{m_p + m_e} \right)^3 \frac{m_e}{m_p} \frac{\mu_p}{\mu_N} \alpha^2 c R_\infty (1 + \Delta) \quad (1)$$

where  $m_p$ ,  $m_e$  are the masses of the proton (antiproton) and electron (positron),  $\mu_p$  the magnetic moment of the proton (antiproton),  $\mu_N$  the nuclear magneton,  $\alpha$  the fine structure constant,  $c$  the speed of light,  $R_\infty$  the Rydberg constant and  $\Delta$  a correction term due to higher-order quantum electrodynamic (QED) and quantum chromodynamic (QCD) effects.

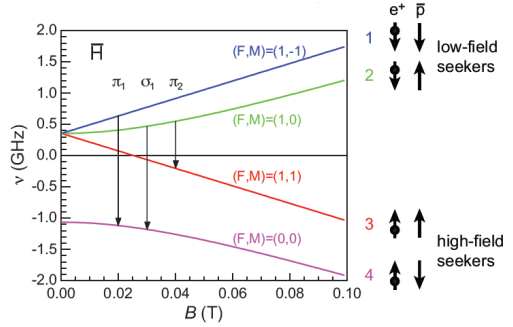

Figure 1: Energies of the four hyperfine states versus an external magnetic field. From [2].

Since the frequency is very well known in hydrogen [3], its antimatter counterpart, if measured with similar precision, will challenge the currently most sensitive CPT limit.

## EXPERIMENTAL SETUP

After extraction of the antiproton beam from the AD the antiprotons are cooled further and finally captured in a cusp trap (anti Helmholtz coil) where ground state  $\bar{H}$  will be formed [4]. The magnetic field of the trap is such that it allows the extraction of a partially polarized  $\bar{H}$  beam containing more low field seekers than high field seekers. This beam is then projected onto a cavity and from the cavity to a superconducting sextupole magnet with a field of 3T focusing the beam onto a multi channel plate (MCP) detector (Figure 2).

If the radio frequency field of the cavity is set to the resonance frequency of 1.42 GHz a spin flip is induced in the  $\bar{H}$  beam leading to a change in polarization from a low field seeker to a high field seeker state. This causes a deflection instead of a focusing in the sextupole magnet and hence a drop in the count rate of the detector is observed. The whole setup from the exit of the trap to the detector is at room temperature.

A vacuum of  $\leq 10^{-10}$  mbar is needed throughout the experimental setup. Each component therefore is bakeable and has its own pumping unit to ensure this pressure.

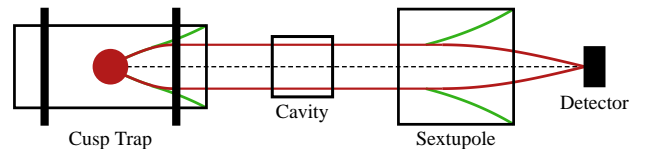

Figure 2: Schematic overview of the experimental setup.

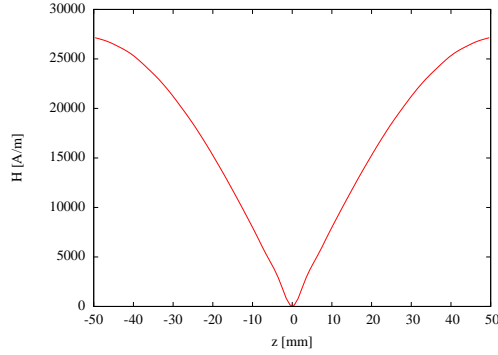

Figure 3: Absolute value of the magnetic field along the beam axis. As expected, the field has a sinusoidal run.

### SPIN FLIP CAVITY

Since the rate of  $\bar{H}$  atoms passing through the cavity is in the order of 1 – 10 atoms per second over a beam aperture of 10 cm diameter the requirements on the field distribution and homogeneity inside it are severe. The radio frequency field of the cavity has to provide a purely transverse field with a homogeneity of at least  $\pm 10\%$  over the whole aperture. Since we cannot have a homogenous field in all directions, the field gradient in beam direction is sinusoidal (Figure 3).

Superimposed to the oscillating field a static magnetic field provided by two Helmholtz coils must be applied to avoid spontaneous spin flips (Majorana spin flips) occurring in field free regions.

To ensure the homogeneity of the field inside the cavity, fringe fields from the cusp trap which are in order of  $\approx 100$  G as well as from the superconducting sextupole ( $\approx 10$  G) have to be shielded to  $< 0.1$  G. As shielding possibility layers of  $\mu$  material are currently investigated with simulations.

For the cavity design, many different setups have been tested using CST Microwave Studio simulation code [5]. Starting from very simple rectangular and pillbox structures up to fairly complex structures such as crab cavities were investigated. Most of the setups could not satisfy the restrictions in field homogeneity and transverse purity.

Also the concept of magnetic walls [6] for the cavity have been investigated since they would provide a purely transverse and totally homogeneous field. In our case such walls are not applicable since they require waves propagating rectangularly to the walls. In the present case the angle of the incident waves however does not satisfy this condition. A setup that provides the desired objectives will be presented in more detail.

### Standing vs. Traveling Wave Structure

Since the beam aperture (10 cm diameter) is comparable to the overall length of 10.5 cm ( $\lambda/2$  structure) fringe field effects become very important for traveling wave structures. Together with the fact that the frequency bandwidth

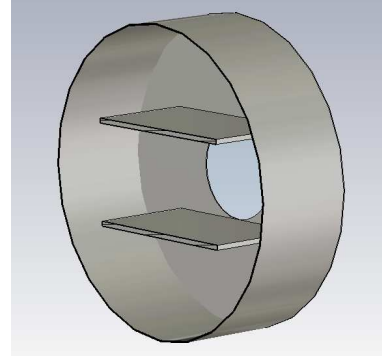

Figure 4: Schematic drawing of the pillbox cavity with two striplines.

should only be about 4 MHz implying a low Q value, and hence a possible reduction of the radio frequency power, a standing wave structure was chosen.

### Pillbox with stripline and wings

A structure consisting of a simple pillbox cavity of 320 mm diameter and 105 mm length with two striplines on top and bottom of the beam aperture proved to be well suited for the application (Figure 4). It provides a purely transverse field with an excellent homogeneity of  $\pm 1.5\%$  (Figure 5).

Unfortunately in addition to the wanted mode there is another one at nearly the same frequency (Figure 6). In order to detune this unwanted mode, small metal plates (wings) have been inserted [5] on the side of the cavity affecting the unwanted mode only. The obtained shift in resonance frequency of the undesired mode from 1.42 GHz to 1.48 GHz is more than enough for selective excitation. This structure is very simple but nevertheless providing all desired properties. It was therefore chosen as final design.

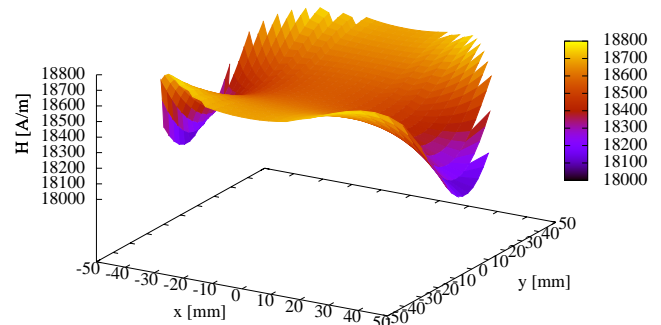

Figure 5: Distribution of the field over the aperture plane perpendicular to the beam.

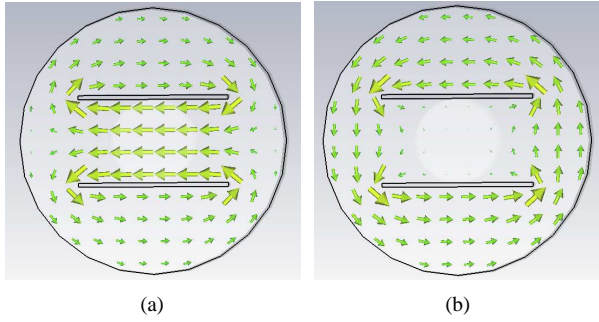

Figure 6: The magnetic field distribution of the desired (a) and the undesired mode (b).

## IMPLEMENTATION OF THE FINAL DESIGN

The goal of the spin-flip cavity design was easy handling and manufacturing of its components. The chosen structure was designed to be completely dismountable and suitable for bake out at 300 °C.

The cavity and all components are fabricated from stainless steel 316LN or 316L using as far as possible standard vacuum components, a sketch of the cavity design is shown in Figure 7.

The upstream and downstream part of the cavity is equipped with 16 1/2" OD CF flanges and adapter flanges providing the transition from the cavity to the beamline vacuum chamber. The cavity body is welded on the inner 16 1/2" OD CF blind flange through which a hole of 300 mm diameter is drilled. The striplines are screwed onto the front and back of the cavity using silver coated stainless steel screws. The wings are spot welded in three places to the side of the cavity. There will be one port (DN 35 CF) on top of the cavity to connect a Penning gauge for pressure

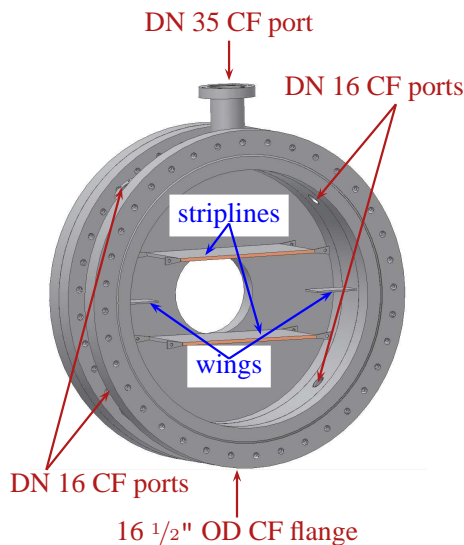

Figure 7: Design of the new spin flip cavity.

measurements. Four DN 16 CF feedthroughs, equipped with coupling pins, will be used around the cavity — two coupling pins for excitation of the desired mode and two for monitoring the excitation. To ensure good electrical contact, copper–beryllium springs are placed between the striplines and the cavity walls and all contacts will be gold plated, i. e. the front and back of the striplines, contacting part of the front and back of the cavity.

Specially manufactured meshes with 96% transparency for the  $\bar{H}$  atoms are used at the entrance and exit of the cavity as well as in the transition to the DN 35 CF flange to ensure the properties of a perfectly closed resonator.

Tuning over the desired frequency bandwidth of 4 MHz will be achieved via the low Q factor of the cavity. Additional tuning can be obtained by displacing the meshes at the entrance and/or exit of the cavity and hence varying the inner length of the resonator. Simulations of this tuning process are in progress.

## SUMMARY AND OUTLOOK

Measurements of the  $\bar{H}$  ground state hyperfine splitting provide an excellent test for CPT violation. The experimental setup currently built within the ASACUSA collaboration at CERN's AD was briefly presented and the design of a spin flip cavity with the field requirements were discussed. Currently proper magnetic shielding possibilities for the cavity and their actual implementation are investigated.

## ACKNOWLEDGEMENTS

The authors would like to thank E. Ciapala and E. Chapochnikova as well as the ABP group for their support. Furthermore, our thanks go to T. Kroyer and B. Salvant for many helpful tips and discussions. We also acknowledge the support and valuable discussion of the ASACUSA collaboration. This work was supported by the Austrian Ministry of Science and Research.

## REFERENCES

- [1] Ryugo S. Hayano, Masaki Hori, Dezső Horváth, Eberhard Widmann: Antiprotonic helium and CPT invariance, Reports on Progress in Physics, Vol 70, 1995 (2007)
- [2] B. Juhász, E. Widmann, Hyp. Int. 193 (2009) 305
- [3] N.F. Ramsey: Nobel Lecture (1989)
- [4] M. Shibata, A. Mohri, Y. Kanai, Y. Enomoto, Y. Yamazaki: Compact cryogenic system with mechanical cryocoolers for antihydrogen synthesis, Review of Scientific Instruments 79, 015112 (2008)
- [5] T. Kroyer: Design of a Spin-Flip Cavity for the Measurement of the Antihydrogen Hyperfine Structure, CERN-AB-Note, 2008
- [6] P-S. Kildal: Artificially Soft and Hard Surfaces in Electromagnetics, IEEE VOL. 38, NO. 10, October 1990