

**RADIATION TESTS ON THE COMPLETE SYSTEM OF THE INSTRUMENTATION
OF THE LHC CRYOGENICS AT THE CERN NEUTRINOS
TO GRAN SASSO (CNGS) TEST FACILITY**

E. Gousiou, G. Fernandez Penacoba, J. Casas Cubillos, J. de la Gama Serrano

Abstract

There are more than 6000 electronic cards for the instrumentation of the LHC cryogenics, housed in crates and distributed around the 27 km tunnel. Cards and crates will be exposed to a complex radiation field during the 10 years of LHC operation. Rad-tol COTS and rad-hard ASIC have been selected and individually qualified during the design phase of the cards. The test setup and the acquired data presented in this paper target the qualitative assessment of the compliance with the LHC radiation environment of an assembled system. It is carried out at the CNGS test facility which provides exposure to LHC-like radiation field.



Radiation tests on the complete system of the instrumentation of the LHC cryogenics at the CERN Neutrinos to Gran Sasso (CNGS) test facility.

E. Gousiou, G. Fernandez Penacoba, J. Casas Cubillos, J. de la Gama Serrano

CERN, 1211 Geneva 23, Switzerland

Evangelia.Gousiou@cern.ch

Abstract

There are more than 6000 electronic cards for the instrumentation of the LHC cryogenics, housed in crates and distributed around the 27 km tunnel. Cards and crates will be exposed to a complex radiation field during the 10 years of LHC operation. Rad-tol COTS and rad-hard ASIC have been selected and individually qualified during the design phase of the cards. The test setup and the acquired data presented in this paper target the qualitative assessment of the compliance with the LHC radiation environment of an assembled system. It is carried out at the CNGS test facility which provides exposure to LHC-like radiation field.

I. THE CRYOGENIC INSTRUMENTATION ELECTRONICS

The cryogenic instrumentation electronics are placed all around the LHC tunnel and in protected areas.

Concerning the tunnel electronics, radiation was a main constraint since the beginning of the design phase. Space or military technologies were incompatible with the budget of the project and instead, Components Off The Shelf (COTS) were selected, qualified for operation under radiation and finally used [1, 2].

Adversely, the protected areas electronics have not been designed radiation-tolerant, as the radiation levels in the protected areas were quite underestimated. Many of the components of the protected areas electronics are the same as the tunnel ones; nevertheless, there are several components for which no information exists for their performance under radiation.

The aim of the tests at the CNGS facility is to validate the complete systems (rather than individual components) in both cases: tunnel and protected areas electronics.

The cryogenic instrumentation electronics (in the cases of tunnel and protected areas as well) are divided into conditioners, measuring temperature, pressure, liquid helium level and digital status, and into actuator channels, providing AC and DC power to the areas where helium needs to be heated-up. Figure 1 shows the architecture of the system, in the case of conditioner channels. A conditioner card holds two independent channels. Each channel has a front end ASIC taking measurements on a sensor. The resulting waveform is sent for digitization to the ADC. A 16 bit word is then sent to the FPGA for the first stage of processing and the formatting of the data provided to the communication card. Up to 15

channels may be interfaced with the same communication card, which implements the WorldFIP protocol and places the data on the Fieldbus.

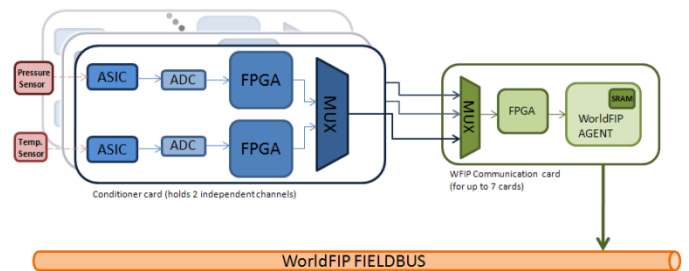

Figure 1: System architecture

The system offers very high accuracy, due to its auto calibrating features [1]:

- For each measurement on a sensor, there is a measurement on a high precision reference resistance which permits the correction of the gain drifts.
- The polarity of the input of the amplifier is inverted so as to correct its offset.
- Finally, the excitation current is applied in both directions in order to compensate for the thermocouple effects, as well as any dc offsets of the wiring.

II. RADIATION TOLERANCE STRATEGY

The radiation, in the case of the LHC tunnel electronics, was faced in two main ways: an elaborate components selection and a set of mitigation techniques [1].

A. Components Selection

- Customized development of a radiation hard front end ASIC and of a linear voltage regulator for power supplies and references.
- Use of anti-fuse FPGAs.
- Selection of a Fieldbus agent (implementing the WorldFIP protocol) that uses signal transformers instead of optical insulators.
- Qualification for operation under radiation of all the components in dedicated facilities [2,3].

B. Mitigation Techniques

- Triple module redundancy is implemented on the FPGA registers.
- The weakest part of the data acquisition chain is a SRAM within the WorldFIP agent. Since SRAMs are usually prone to SEU, in a way to reduce the probability of an error, it is regularly refreshed.



Figure 2: Timing for data transfer between the different parts of the system

As Figure 2 indicates, the exchange of data between a conditioner card and its communication card takes place every second; the same timing is applied in the case of the exchange between the communication card and the Fieldbus. Within the communication card, between the robust FPGA and the SRAM, there is however a refreshment period of 20 msec.

- All the current supplies and the thermal dissipators are oversized.
- Finally, during maintenance campaigns, scheduled replacements are being foreseen where needed.

III. THE CNGS TEST FACILITY

The CNGS test facility is housed in the service gallery of the CNGS experiment [4]. The shower of particles escaping through the ducts, connecting the main tunnel with the service gallery, is irradiating the Devices Under Test (DUT). The radiation levels depend on the position in the gallery (Figure 3). The radiation field is mixed (TID, NIEL and particles with $E > 20\text{MeV}$ simultaneously), as in the LHC. Since the field is wide and relatively homogeneous [5], testing complete systems becomes possible.

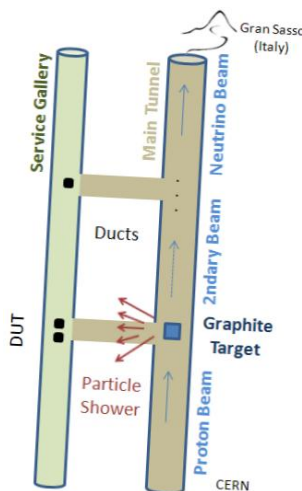

Figure 3: CNGS main tunnel and service gallery

The facility provides:

- Several connections to the mains, protected with breakers.
- Real time radiation monitors and an online system for the data extraction.
- The WorldFIP communication.
- The possibility to transfer up to 96 signals from the DUT in the radiation area to the control room of CNGS at a distance of 2 km.

IV. THE TEST SETUP

A. Devices Under Test

Two crates were used to house all types of electronics (conditioners, actuators, communication and power cards), representing finally 50 channels of LHC tunnel and 16 channels of protected areas electronics.

Completing the setup, fixed loads were plugged into all the conditioners and in the same way fixed set points were given to all actuator channels; this way constant measurements throughout the tests are expected.

B. Data Acquisition

Two types of on line data is acquired:

- The WorldFIP bus data, in exactly the same way as in the LHC.
- Current consumption and DC voltage levels measurements. In order to gain access to those signals from the DUT, modifications needed to be made to the crate power supply card. Briefly, the power supply card receives the mains and provides the DC voltages required by all the cards in a crate. A $1\ \Omega$ resistance was inserted in series in the PCB tracks of the power card (Figure 4). The voltage drop across this shunt resistor provided an image of the current able to be read over the 2 km cables. A measurement set-up based on LabVIEW, a DMM and a switching module located at the control room of CNGS retrieves and stores these measurements.

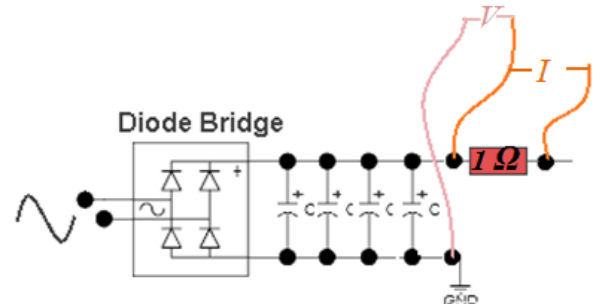

Figure 4: Measurements on the power supply card

C. Testing Periods

- The tests started with 1 month of dry run. During the first half of this period, the electronics were installed in the control room of CNGS and during the second half in the radiation area, in the same position as during the irradiation. This provided a clear confirmation of the reliability of the electronics and of the measurement system as well.
- The testing continued with 1.5 months in the low dose station of CNGS. Since it was the first time the complete system was tested, it was decided to start moderately in the low dose station. The radiation levels received during this period are given in Table 1:

Table 1: Radiation levels at the low dose station

TID (Gy)	18
NIEL (n/cm ²)	$2.6 \cdot 10^{11}$
20MeV (p/cm ²)	$1.3 \cdot 10^{11}$

- Finally, the equipment was moved to the high dose station. In 1.5 months, the radiation levels received are given in Table 2.

Table 2: Radiation levels at the high dose station

TID (Gy)	105
NIEL (n/cm ²)	$3.6 \cdot 10^{12}$
20MeV (p/cm ²)	$2 \cdot 10^{12}$

V. RADIATION TEST RESULTS

A. Tunnel Electronics

The tests confirmed that the design of the tunnel electronics is well within the LHC radiation requirements. Until now, they have received in total 125 Gy and $4 \cdot 10^{12}$ 1MeV eq. n/cm² and at the end of the test the levels are expected to reach 185 Gy and $6 \cdot 10^{12}$ 1MeV eq. n/cm². No influence on the output accuracy, in any of the 50 channels under test, has been noted neither an increase of the current consumption. Also, no SEE has been detected.

The extrapolation of those data to the LHC conditions [6, 7, 8], considering nominal operation, gives **more than 10 LHC years (*)** for 95% of the cases. Regarding the remaining 5% (which represents electronics installed in the Dispersion Suppressor areas) the radiation tolerance in terms of nominal LHC years is currently estimated at 2.5 (*) and the value is expected to increase by the end of the tests.

Figure 5 shows the output of 5 different channels and Figure 6 focuses on one channel adding the design specs limits.

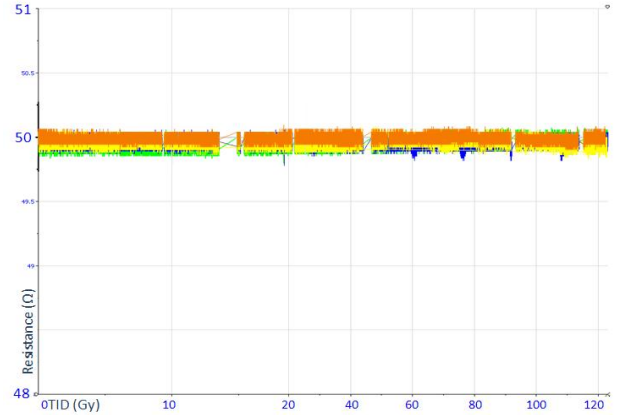

Figure 5: Output of 5 channels

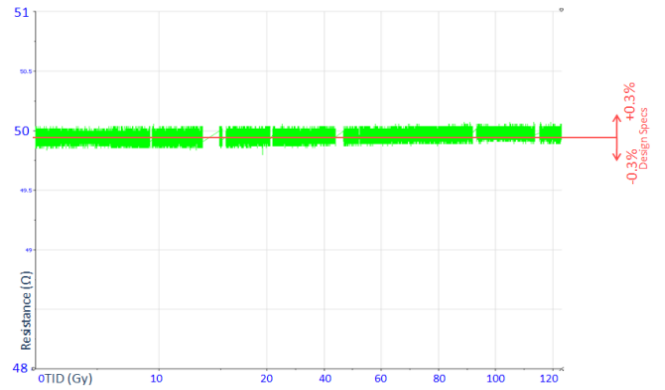

Figure 6: Output of one channel and design specs

B. Protected Areas Electronics

1) Insulated Temperature Conditioners

There are around 2400 channels of this type of electronics in the protected areas of the LHC. During the tests at CNGS, two types of failures were encountered: failures due to cumulative effects (TID, NIEL) and SEUs.

i. Cumulative Effects

Twelve channels failed simultaneously after 70 Gy and $2 \cdot 10^{12}$ 1MeV eq. n/cm². Since the radiation field is mixed it is not possible to understand if the TID or the NIEL is the main reason of the failure. Nevertheless, as the field at CNGS is LHC-like, TID and NIEL give a correspondence to approximately the same number of LHC years. The extrapolation to the LHC conditions [9], considering nominal operation, gives for **94%** of the channels **more than 10 LHC years (*)**. For the remaining **6%** (which represents channels installed in the worst-case locations: UJ14, UJ16 and UJ56) the **nominal LHC years** are reduced to **4 (*)**.

The failing component is a DC-DC converter. After its replacement, the channels were functional again.

ii. SEU

The SEU **cross section** estimated from the test results is $2 \cdot 10^{-9}$ cm². The extrapolation to the LHC conditions [9], considering nominal operation and accounting the total amount of channels, gives **6 SEU/ hr (*)**.

The implementation of a mitigation technique is already in progress and consists of a software reset to be automatically launched by the control system.

The appearance of a SEU is illustrated in the following figures:

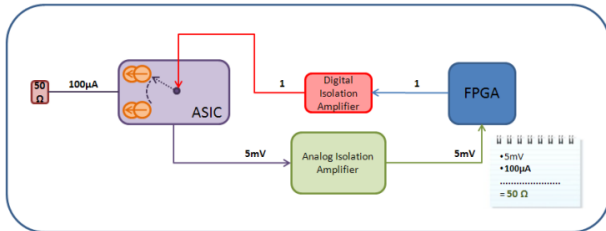

Figure 7: Insulated temperature channel in normal operation

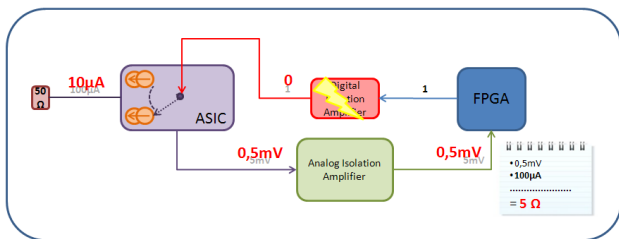

Figure 8: Insulated temperature channel when a SEU occurs

2) AC Heater Actuator

The AC heater actuators represent less than the 0.5% (45 channels in total) of the cryogenic instrumentation electronics and are only found in protected areas. They receive the mains and a set point and with a solid state relay provide a Pulse Width Modulation of the mains to a heater.

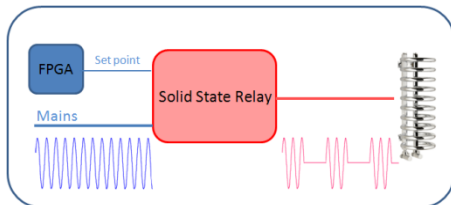

Figure 9: AC heater actuator channel

Three AC heater channels failed in the low dose radiation station after exposure to 5 Gy and $7 \cdot 10^{10}$ 1MeV eq. n/cm².

The failing component was the solid state relay which functions with optocouplers. When it was replaced the cards were functional again. Figure 8 shows the three channels failing almost simultaneously.



Figure 10: Three AC heater channels failing at the low dose station

The same results were later reproduced with four more channels in the high dose radiation station.

Considering nominal LHC operation [9] for **65%** of the channels, we get **more than 10 LHC years** (*). In the worst-case locations (UJ14, U16 and UJ56 where **20%** of the channels are installed) the **nominal LHC years** are reduced to **0.3** (*). However, considering the 09/10 LHC operation (where the expected radiation levels are two orders of magnitude lower) the years are increased by two orders of magnitude. Finally, as many commercial components are already installed in the worst case areas, there is a study for either a relocation or for additional shielding; this will also benefit the LHC cryogenic electronics.

VI. CONCLUSIONS

The tests at CNGS have provided qualitative and quantitative knowledge on the radiation tolerance of the complete system of the LHC cryogenics instrumentation. The reliability of the tunnel electronics has been confirmed, whereas the weaknesses of the protected areas electronics have been revealed. In the second case, different techniques of facing the problems are already under implementation.

VII. REFERENCES

- [1] J.Casas et al., "The Radiation Tolerant Electronics for the LHC Cryogenic Controls: Basic Design and First Operational Experience", [Topical Workshop on Electronics for Particle Physics](#), Greece, 15 - 19 Sep 2008, pp.195-199.
- [2] J. A. Agapito et al., "RAD-TOL Field Electronics for the LHC Cryogenic System", [7th European Conference On Radiation And Its Effects On Components And Systems](#), Noordwijk, The Netherlands, 15 - 20 Sep 2003, pp.653-7.
- [3] J.Casas et al. "SEU Tests Performed on the Digital Communication System for LHC Cryogenic Instrumentation", [Nucl. Instrum. Methods Phys. Res., A 485, 3 \(2002\) 439-43](#).
- [4] K. Elsener, "General description of the CERN project for a neutrino beam to Gran Sasso (CNGS)", CERN AC Note, 2000-03.
- [5] M. Brugger, "FLUKA CNGS Radiation Levels @ RadMonLocation", RadWG meeting, 24/04/2009.
- [6] C. Fynbo, G. Stevenson, "Compendium of annual doses in the LHC arcs", LHC Project Note 251, 4 April 2001.
- [7] C. Fynbo, G. Stevenson, "Radiation Environment in the Dispersion Suppressor regions of IR1 and IR5 of the LHC", LHC Project Note 296, 27 May 2002.
- [8] C. Fynbo, G. Stevenson, "Estimation of extra dose contribution in the LHC arcs arising from proton losses far downstream of the high luminosity interaction points IP1 & IP5", LHC Project Note 295, 27 May 2001.
- [9] Radiation-To-Electronic Study Group (R2E), <https://ab-div.web.cern.ch/ab-div/Meetings/r2e>

(*) A safety factor of 2 has been applied.