

STATUS OF THE SPL

O. Brunner, S. Calatroni, E. Ciapala, R. Garoby, F. Gerigk, A.M. Lombardi, R. Losito, V. Parma, C. Rossi, J. Tuckmantel, M. Vretenar, W. Weingarten, CERN, Geneva, Switzerland

Abstract

The construction of the Large Hadron Collider (LHC) at CERN is now completed and beam commissioning has begun in October 2008. Following the recommendations of the European Strategy Group for Particle Physics, a work programme has been launched for maximizing the physics reach of the LHC and for preparing for other foreseeable needs. It includes the renewal of the LHC injector complex in 2 phases. The first phase, which started in January 2008, includes the construction of a new 160 MeV H^- linac (Linac4) to replace the present 50 MeV proton linac (Linac2) and the study of a Superconducting Proton Linac (SPL) and of a new 50 GeV synchrotron (PS2). The construction of the SPL, together with PS2, will be the subject of the second phase, which should begin in 2012. As a first step of the SPL study, the basic design choices of the SPL have been revisited.

INTRODUCTION

The different scenarios foreseen for increasing the luminosity of the LHC require improved beam characteristics from the injectors, out of reach of the present complex [1]. Hence is it necessary to plan for new accelerators that can satisfy the needs of the most demanding scenario with a reasonable operational margin. Moreover, the generation of the beam for LHC is using sophisticated beam gymnastics and pushing the equipment in the injectors to its limit, which combines with the age of many components to degrade reliability. That will be especially unacceptable for the upgraded LHC whose integrated luminosity will strongly depend upon the dead time between physics coasts.

The SPL is an essential component of the proposed future accelerator complex [2], shown in Figure 1 together with the present machines. For the needs of PS2, only a 4 GeV low power version of the SPL is needed (the “LP-SPL”). For a neutrino facility, it would have to be upgraded to 5 GeV and 4 MW of beam power, and accompanied with an accumulator and a compression ring to meet the required time structure of the beam [3]. For a Radioactive Ion Beam Facility of the next generation [4], a similar beam power would also be required at 2.5 GeV. A summary of the specifications of the accelerator in its different phases of implementation is given in Table 1.

As a first step in the preparation for the project proposal, the choice of the basic parameters of the SPL has been revisited during the past months [5] in view of optimizing synergy with the worldwide development effort on superconducting accelerating structures. The RF frequency was therefore reconsidered, as well as the cooling temperature of the superconducting cavities and the foreseeable accelerating gradients [6].

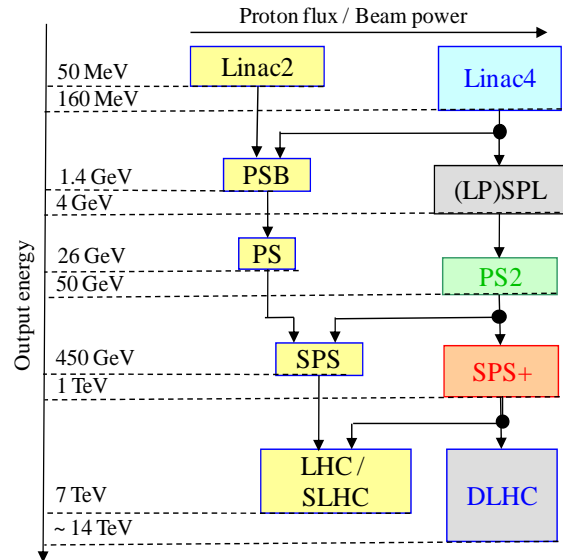

Figure 1: Present and proposed future accelerators:

- Linac4: 160 MeV H^- linac
- LP-SPL: (Low Power) Superconducting Proton (H^-) Linac (~5 GeV)
- PS2: new proton synchrotron (~50 GeV)
- SPS+: superconducting SPS (~1 TeV)
- SLHC: LHC with luminosity upgrade
- DLHC: double energy LHC.

Table 1: Successive Phases of Implementation of the SPL

	LP-SPL	SPL (5 GeV)	SPL (2.5 GeV)
Users	PS2 ISOLDE	+ ν facility	+ RIB facility
T [GeV]	4	5	2.5
P_{beam} [MW]	0.2	4	4
F_{rep} [Hz]	2	50	50
I_{source} [mA]	40	80	80
Chopping	yes	yes	no
I_{av} [mA]	20	40	40
T_{pulse} [ms]	1.2	0.4	0.8

DESIGN OPTIONS

The RF frequency being 352 MHz in Linac4, only harmonics can be considered for the superconducting cavities in the following linac. The three design options which have been considered for the SPL [6] (see Table 2) were especially aimed at analysing the interest of 1408 MHz (4×352 MHz) which is close to the frequency used in the ILC and X-FEL projects.

Table 2: SPL Design Options

	Nominal	High frequency	Hybrid
Frequency [MHz]	704	1408	352/1408
Type of cavities	elliptical	elliptical	spoke/elliptical
$\beta_{\text{geometrical}}$	0.65/0.92	0.6/0.76/0.94	0.67/0.8/0.94
Number of cells/cavity	5/5	7/9/9	4/5/9
Input energies/section [MeV]	160/581	160/357/884	160/392/758
Accelerating gradient* [MV/m]	19.4/24.2	18.1/21.7/24.2	8.5/9.5/24.2
Number of cavities/focusing period	3/8	2/4/8	3/4/8
Number of cavities	42/200	30/40/208	27/24/216
Total number of cavities	242	278	267
Length of sc linac	439	499	485

* Normalized for elliptical cavities to a peak surface field of 50 MV/m.

The “Nominal” option in Table 2 is a slightly improved version of the SPL design published in 2006 [7]. It uses only 2 types of 5 cell elliptical cavities and has a length of 439 m. In the “High frequency” option, 1408 MHz elliptical cavities are used immediately after Linac4. To preserve comparable real-estate gradient, cavities with more cells must be used, which reduces their energy range and forces to have three different types. Moreover, the accelerator length has to be 60 m longer because of the longer matching section needed by the x4 frequency jump. In the “Hybrid” option, the transition to 1408 MHz is done at 758 MeV only, using spoke cavities operating at 352 MHz immediately after Linac4. Two different types of Spoke and one type of elliptical cavities are needed. The total length remains 46 m longer than in the nominal case.

ANALYSIS

Beam dynamics

Similar design principles are used in all options. Beam dynamics performance is compared in terms of r.m.s. emittance growth and sensitivity to RF field errors.

Transverse emittance growth is small in all cases [between 1.5 (5.3) and 5.6 (8.2) % for ϵ_x (resp. ϵ_y)], with a slight advantage for the “hybrid” option. The situation is more contrasted in the longitudinal phase plane where the “high frequency” option is clearly worse (12 % blow-up instead of 6.8 % and 2.5 % in the “nominal” and “hybrid” cases). This is confirmed by the analysis of the effect of RF field errors and energy/phase jitter of the Linac4 beam, 4.2 % of the simulation runs showing particle loss with the “high frequency” option.

Impact of frequency on cavity parameters

The impedance per unit of length is proportional to the cavity resonant frequency (f).

For the same accelerating gradient, the stored energy in a 1408 MHz multi-cell cavity, is $\frac{1}{4}$ of the energy stored in a 704 MHz cavity of the same length (and less cells). Since SPL cavities are pulsed, filling them with RF field uses four times more wall-plug power at 704 MHz.

For longitudinal High Order Modes (HOM), similar reasoning shows that the short range wake-field is 4 times larger in a 1408 MHz multi-cell cavity. The impedance for long range longitudinal wake-fields is between 8 and 16 times larger, depending upon the mode. The impedance for transverse long range dipole modes is between 8 and 32 times larger, resulting in a reduction by the same factor of the threshold for the onset of beam break-up.

In the case of real/imperfect structures, the production scatter in the individual cell frequencies and end-cell correction for the fundamental mode disturbs the HOM field profiles. This makes their coupling and hence their damping more uncertain by a factor 2 to 4 in the 1408 MHz case.

Impact of frequency on RF hardware

RF equipment is more compact at higher frequency, which increases the difficulty to dissipate the heat generated at ~ 10 % duty cycle. 1 MW class hybrids and amplitude & phase modulators will be especially challenging to design at 1408 MHz. For klystrons, manufacturers have clearly expressed their reluctance for similar reasons.

Cryogenics issues

The design of the SPL cryomodule will re-use as much as possible of the state-of-the-art development made for the ILC. Static cryogenic losses are minimized using a long cryomodule with a high packing factor and containing the helium supply and return pipes. The pumping return line is also a structural element securing the alignment of the cavities and magnets. It is however

impossible to duplicate exactly the ILC device because of the 1.7 % slope of the SPL (ILC: 0.6 %), and because of the 10 times higher duty factor of the SPL which imposes new designs for the RF and HOM couplers.

The quality factor Q_0 of superconducting elliptical cavities is more than 20 times larger at 2 K than at 4.5 K, for both frequencies, and more than 2.5 times higher at 704 than at 1408 MHz. Taking these estimates and static loads [7] into account, the equivalent cryogenic load of the 5 GeV-4 MW SPL for the “nominal” and “high frequency” options is given in Table 3. Electrical power consumption imposes clearly to operate cavities at much lower temperature than 4.5 K.

Table 3 also shows the power required by RF which is ~ 9 MW larger at 704 MHz because of the larger stored energy in the cavities (see above).

Table 3: Cryogenic Load and Electrical Consumption of the 5 GeV/4 MW SPL

Option [see Table 2]	T_{cryo} [K]	$Q_{\text{eq @ 4.5 K}}$ [kW]	$P_{\text{el}}(\text{cryo})$ [MW]	$P_{\text{el}}(\text{RF})$ [MW]
“Nominal”	2	20.8	5.2	25.5
“Nominal”	4.5	95.4	23.9	25.5
“High frequency”	2	18.3	4.6	16.3
“High frequency”	4.5	81.9	20.5	16.3

Achievable gradient

The analysis of cavities recently built for SNS and at DESY [8] shows that, for a yield of 90 %, the maximum achievable equivalent gradient in $\beta=1$ cavities is between 16 MV/m (SNS) and 23 MV/m (DESY). Higher gradients like the 25 MV/m presently assumed in the SPL can only be achieved after reprocessing a large number of cavities and/or with an improved surface treatment (electropolishing). It is therefore important to design and build SPL-type superconducting cavities in the near future to arrive at a realistic estimate.

CONCLUSION AND PLANS

The main advantage of the “high frequency” option is its smaller power consumption, which has to be balanced against its longer length and larger number of cavities and cavity types with respect to the “nominal” option. For a high power proton accelerator where beam losses have to be minimized, it suffers however from less tolerance to energy/phase jitter of the Linac4 front end, higher longitudinal emittance growth and a increased risks related to higher order modes. Moreover, the high power RF components that it requires are much more difficult to design/build/buy. The “hybrid” option suffers from the same drawbacks, plus the need to develop an additional family of cavities (spokes). 704 MHz is hence confirmed as the correct choice for the frequency and ~ 2 K for the cooling temperature of the SPL. Although valuable for the

LP-SPL, these choices are mandatory for the foreseen high power/ high duty cycle extensions.

The accelerating gradient that can be expected with a reasonable yield deserves further investigation.

The main goals of the next 3 years will hence be to:

- optimize the overall design of the SPL,
- build and test 704 MHz superconducting cavities to better estimate the achievable accelerating gradient,
- design and test a solution for stabilization of the field in pulsed mode,
- progress in the development of an H^- ion source,
- design, assemble and characterize a complete high energy cryomodule.

REFERENCES

- [1] M. Benedikt et al. (ed.) “LHC Design Report: Volume III: The LHC Injection Chain”, CERN-2004-003, Chapter 2 p.5 and Chapter 7 p.45.
- [2] R. Garoby, “Upgrade Issues For The CERN Accelerator Complex”, EPAC’08, Genoa, June 2008, FRYAGM01, p.3734 (2008), <http://www.JACoW.org>.
- [3] M. Aiba, “Feasibility Study of Accumulator and Compressor for the 6-bunches SPL based Proton Driver”, CERN-AB-2008-060.
- [4] EURISOL report 2004, http://www.ganil.fr/eurisol/Final_Report/EURISOL-REPORT.pdf.
- [5] Workshop on “Status of Analysis of SPL RF Frequencies and Cooling Temperature”, 2008, CERN <http://indico.cern.ch/conferenceDisplay.py?confId=32631>.
- [6] O. Brunner et al., “Assessment of the basic Parameters of the CERN SPL”, CERN-AB-2008-067-BI-RF.
- [7] F. Gerigk (ed.), “Conceptual Design of the SPL-II”, CERN-2006-006.
- [8] W. Weingarten, “Performance of Superconducting Cavities as required for the SPL”, CERN-AB-2008-063.