

LARGE TRANSVERSE MOMENTUM HADRONIC PROCESSES

P. Darriulat

Geneva - 6 August 1976

Rapporteur's talk given at the  
18th International Conference on High-Energy Physics  
Tiflis, GSSR, 15-21 July 1976



P. Darriulat  
CERN, Geneva, Switzerland

## I. Introduction

The possible relation between deep inelastic lepton production and large transverse momentum ( $p_T$ ) processes in hadronic collisions was first considered by Berman and Jacob<sup>1)</sup> and by Berman, Bjorken and Kogut<sup>2)</sup>.

Berman and Jacob<sup>1)</sup> generalized the relation between the proton form factor and the large  $|t|$  behaviour of elastic proton-proton scattering, following the suggestion that electromagnetic and hadronic distributions within a nucleon are the same<sup>3)</sup>.

Berman, Bjorken and Kogut<sup>2)</sup> proposed an explicit quark-parton picture of large  $p_T$  production directly inspired from the deep inelastic electron scattering equivalent. According to their model, large  $p_T$  production is described by a single binary collision between leading constituents of the colliding hadrons, and the transitions between hadrons and constituents obey the same mechanisms as in deep inelastic electroproduction.

It was in such a context of ideas that three ISR groups<sup>4)</sup>, while measuring single-particle inclusive cross-sections in the large transverse momentum region, observed much larger yields than was commonly expected from a naive extrapolation of the low  $p_T$  exponential behaviour. This demonstrated the feasibility of exploring the large  $p_T$  region with existing machines, and immediately triggered off a big experimental effort which is today starting to come to fruition.

Quark-parton ideas have been very successful in motivating such an effort, placing large  $p_T$  processes at the heart of strong interaction dynamics, in close contact with its most fundamental aspects. With a good dose of optimism, one might have hoped that large  $p_T$  products in a multi-particle final state would carry the relevant kinematic and quantum number contents of the hard-scattered constituents and provide information on their nature and on their interactions, as well as give possible hints toward the understanding of more obscure questions such as the role played by gluons or the puzzle of quark confinement.

Having acknowledged the success of quark-parton ideas in motivating the effort devoted to the field, we are today in a position to give a critical discussion of the experimental data and, free of theoretical prejudice, to analyse the merits of the original motivation.

## II. The Event Structure

Experiments observing the structure of the final state in proton-proton collisions producing at least one large transverse momentum particle, have led to the following conclusions:

- i) A large fraction of the produced particles are unaffected by the large  $p_T$  process. They retain the main properties of "normal" events, where no large  $p_T$  particle is produced.
- ii) The other products -- with transverse momenta  $\vec{p}_T^i$  -- are correlated to the large  $p_T$  particle -- with transverse momentum  $\vec{p}_T^0$ . Depending upon the sign of the scalar product  $\vec{p}_T^i \cdot \vec{p}_T^0$ , they can be separated into two groups of "towards movers" ( $\vec{p}_T^i \cdot \vec{p}_T^0 > 0$ ) and "away movers" ( $\vec{p}_T^i \cdot \vec{p}_T^0 < 0$ ).

I will first review the experimental evidence favouring such a picture and discuss the properties of each of the three groups (underlying normal event, towards movers, and away movers). I will then present some phenomenological interpretations which have recently been given.

## III. The Underlying Normal Event

The pioneer experiment of the Pisa-Stony Brook Collaboration<sup>5)</sup>, presented two years ago at the London Conference, has led their authors to conjecture that a large  $p_T$  event at centre-of-mass energy  $\sqrt{s}$  consists of the superposition of a "normal" event at total energy  $\sqrt{s} - 2|\vec{p}_T^0|$  with a set of secondaries including the trigger itself and particles balancing its transverse momentum  $\vec{p}_T^0$ .

Further support of this idea is now available.

- i) The density of charged particles, and their transverse momentum distribution, in regions of phase space far

Table 1

Trigger			Secondaries			
Type	Polar angle (deg.)	Range of $p_T^0$ (GeV/c)	Particle identification	Momentum measurement	Azimuthal acceptance (deg.)	Ref.
$\pi^0$	90 53	3 to 5	Charged and $\gamma$	No	Full	6
$\pi^0$	90	$\sim 2.5$	Charged	Yes	$0 \pm 27$ $180 \pm 35$	7
Positive Negative	20 45	$\sim 2.5$	Charged	Yes	$0 \pm 25$ $180 \pm 40$	8, 9 10, 11
$p^\pm$ $\pi^\pm$ $K^\pm$	90	$> 2$	Charged	Yes	$0 \pm 30$ $180 \pm 30$ $\pm 90 \pm 15$	12
$p^\pm$ $\pi^\pm$ $K^\pm$	90	1 to 3	Charged	No	Full	13
$\pi^0$	90	$< 4.5$	Charged	No	Full	5

away from the large  $p_T$  trigger is approximately the same as in "normal" events. This observation has been made by several groups<sup>5-13)</sup> and under various trigger conditions (Table 1). It is particularly meaningful in the azimuthal hemisphere centred on the trigger particle, because the towards movers, in contrast with the away movers, do not occupy a large phase-space domain (Figs. 1 and 2).

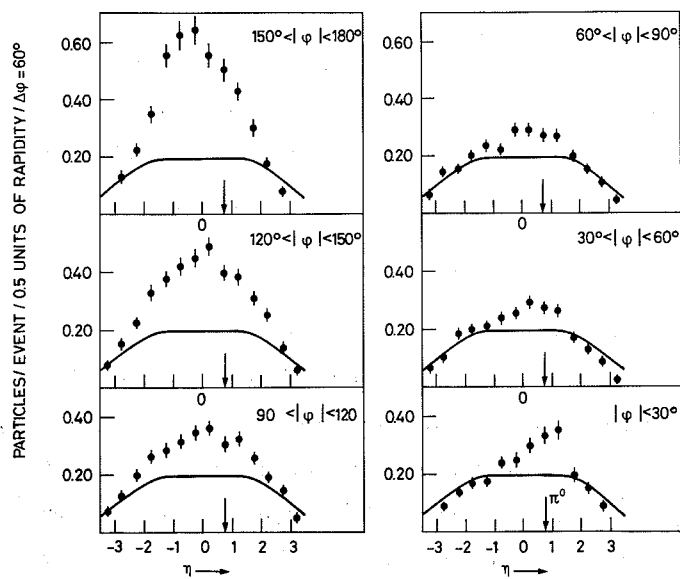

Fig. 1 Rapidity density of charged particles in ISR p-p collisions. The large  $p_T$  trigger  $\pi^0$  is indicated by an arrow (Ref. 6).

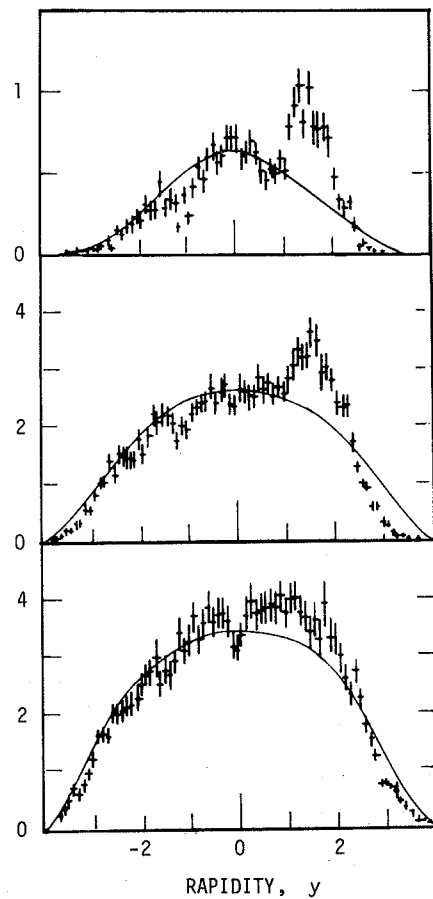

Fig. 2 Rapidity density of negatives with  $|p_x| = 0.3$  to  $0.5$  GeV/c (lower),  $0.5$  to  $1$  GeV/c (middle), more than  $1$  GeV/c (upper) in an azimuthal wedge around the trigger (large  $p_T$  positive at  $20^\circ$ ). Data from Ref. 10.

ii) The density of forward ( $x_L > 0.5$ ) positive particles has been measured<sup>8)</sup> when a large  $p_T^0$  positive is produced backwards ( $-0.5 < x_L < -0.2$ ). As in "normal" events, they outnumber negatives by a large factor, no significant structure is observed in their azimuthal distribution, and their transverse momentum spectrum is not affected. But their  $x_L$  distribution (Fig. 3) shows that the diffraction peak is strongly depressed and that, in addition, the forward density decreases slowly with  $p_T^0$  (Fig. 4). The existence of leading positive particles in large  $p_T$  events is a very important piece of information. If it were to persist at higher values of  $p_T^0$  it would suggest that the large  $p_T$  process is purely central, with no quantum number flow from the incident hadrons to the large  $p_T$  products. More measurements of the particle density and of the charge content in the backward-forward regions are necessary to understand the evolution with  $p_T^0$ , and in particular whether the observed decrease is well explained by the lesser available energy  $\sqrt{s} - 2|\vec{p}_T^0|$ .

iii) Two-particle rapidity correlations between charged products have been measured in events where a large  $p_T \pi^0$  is centrally produced. They display the same short-range structure (Fig. 5) amenable to a description in terms of independent cluster formation as in "normal" events, and this with only little dependence upon azimuth.

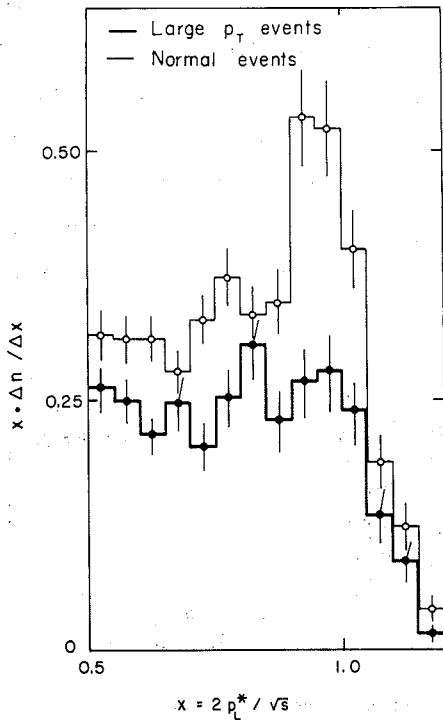

Fig. 3 Leading particles in large  $p_T$  events and depression of the diffraction component (from Ref. 8).

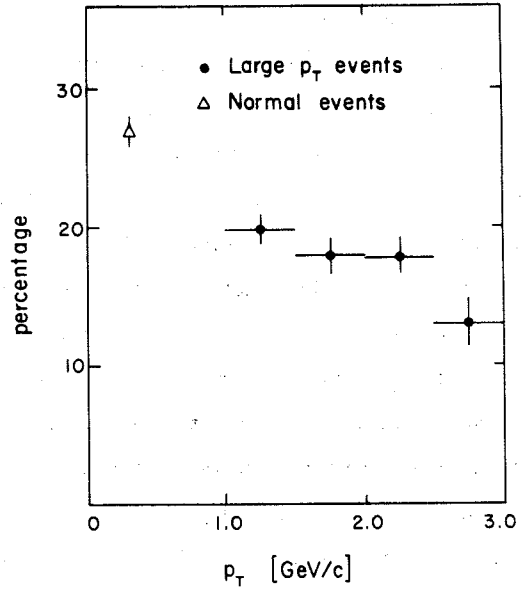

Fig. 4 Percentage of leading particles ( $|x_L| > 0.5$ ) as a function of the trigger  $p_T$  (from Ref. 8).

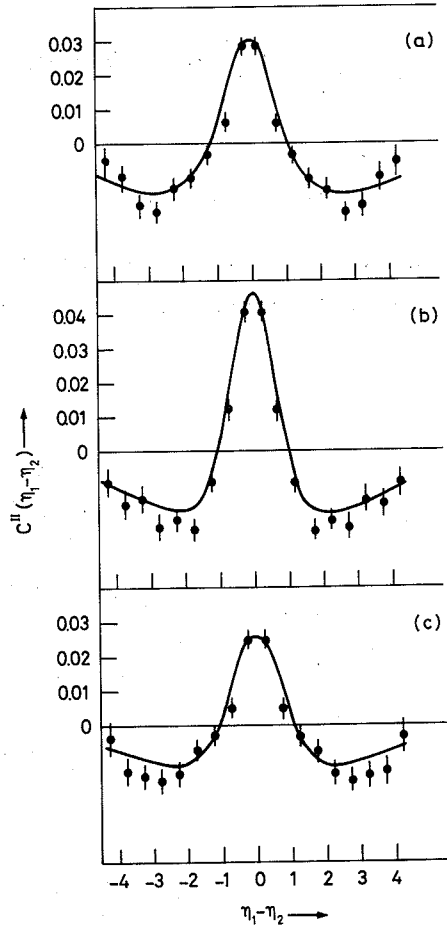

Fig. 5 Average semi-inclusive rapidity correlations in a large  $p_T$  event for the full azimuthal range (a), the away hemisphere (b), and the trigger hemisphere (c). From Ref. 10.

#### IV. The Towards Movers

Momentum correlations between two pions produced alongside one another in the central region have been measured<sup>14,15)</sup> and found to be important. When the transverse momentum of one of the pions is larger than 3 GeV/c, that of the other has a distribution broader than in single-particle inclusive spectra, by a factor of 1.2 to 1.3. When expressed in terms of a correlation coefficient at fixed  $p_T$ , this corresponds to very large values -- one to two orders of magnitude -- because of the steep fall of the production spectra. Within experimental errors, these correlations are independent of the charge combination in the pion pair, suggesting that two-body decays of low-mass resonances do not play an important role<sup>15)</sup> (Fig. 6). Correlation functions are observed to increase slowly with  $s$ , and increase more the larger the  $p_T$ . This can be expressed in a compact form by noting that the two-pion invariant cross-section for "alongside" production at  $90^\circ$  may be written as<sup>14,15)</sup>

$$E_1 E_2 \frac{d^6\sigma}{d^3p_1 d^3p_2} \propto (p_T^1 + p_T^2)^{-n} f(x_T^1 + x_T^2),$$

with

$$x_T^{1,2} = 2p_T^{1,2}/\sqrt{s},$$

where the exponent  $n$  and the function  $f$  are very similar to those describing single-particle inclusive spectra (Fig. 7).

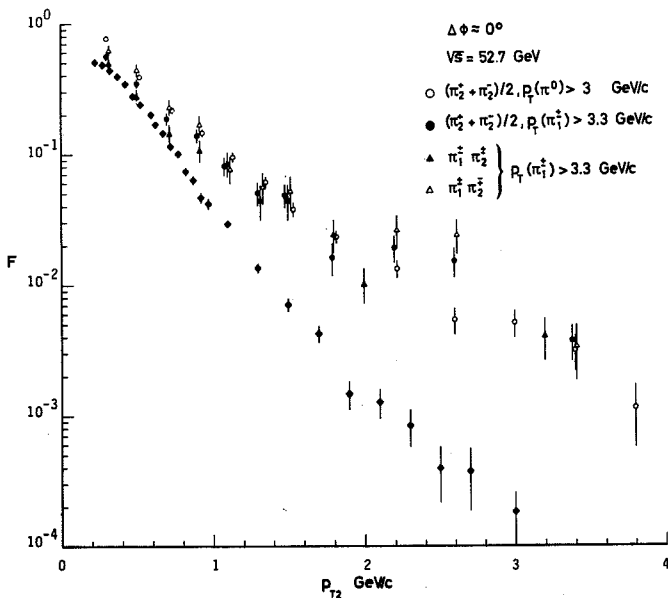

Fig. 6 Momentum correlation function between pions of different charges (towards movers). From Ref. 15.

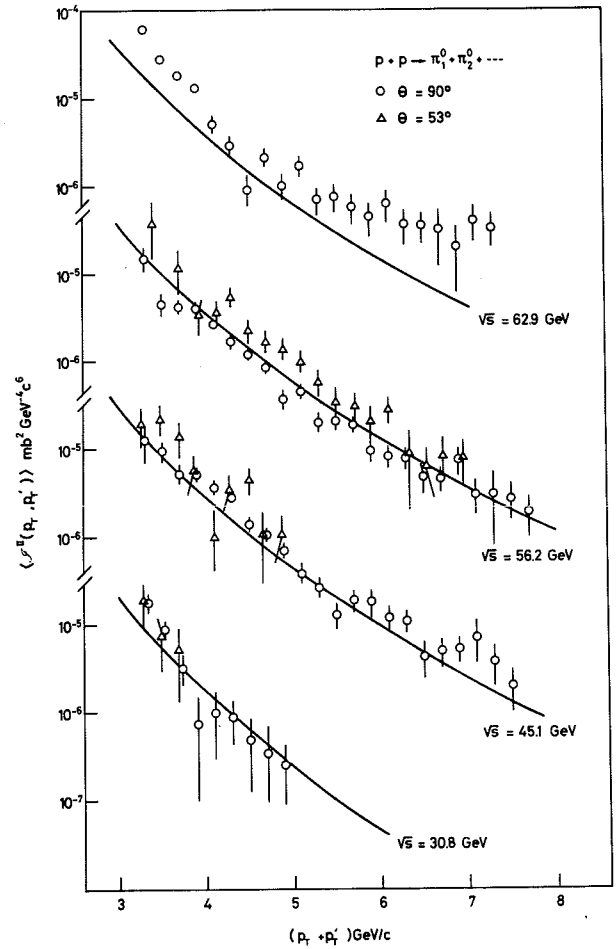

Fig. 7 Invariant cross-sections for production of two alongside  $\pi^0$ 's (Ref. 14).

When observed over a wider domain of phase space, towards movers appear to populate a narrow region around the large  $p_T$  trigger, well within  $\pm 1.5$  units of rapidity and  $\pm 60^\circ$  of azimuth. It is possible to estimate their charged particle content by subtracting from the observed density that of "normal" events. This way,  $0.85 \pm 0.15$  charged particles per event are found<sup>6)</sup>, independent of  $p_T^0$  (Fig. 8).

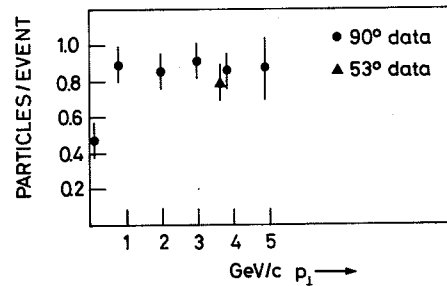

Fig. 8 Population of charged towards movers as a function of  $p_T$  of the  $\pi^0$  trigger (Ref. 6). The point at low  $p_T$  corresponds to the cluster structure in normal events.

Measurements in a narrow azimuthal wedge ( $\pm 30^\circ$ ) around the trigger particle provide cumulative evidence that the towards movers (Fig. 9) have a limited transverse momentum (of the order of 300 MeV/c) with respect to the vector sum of their momenta<sup>7,11,12</sup>). This implies a shrinking of their rapidity distribution when the component of their momentum on that of the trigger increases (Fig. 10), as well as confining to low values their invariant mass with the trigger particle. Searching for structure in the distribution of this invariant mass, some resonance production is indeed observed, but responsible for only part of the correlation among towards movers. Reported resonances<sup>7,12</sup>) include  $\rho^\pm \rightarrow \pi^0 \pi^\pm$  (Fig. 11) -- with a production cross-section

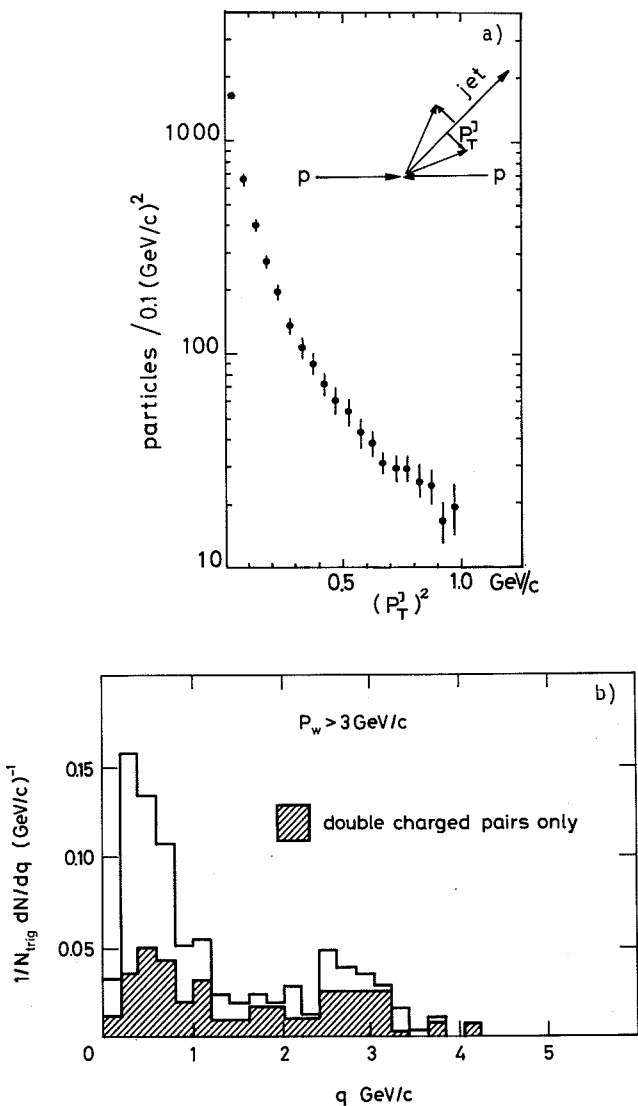

Fig. 9 Transverse momentum distributions along the axis of towards movers:  
a) From Ref. 11 (the background of the underlying "normal" event has been subtracted).  
b) From Ref. 12 (preliminary data).

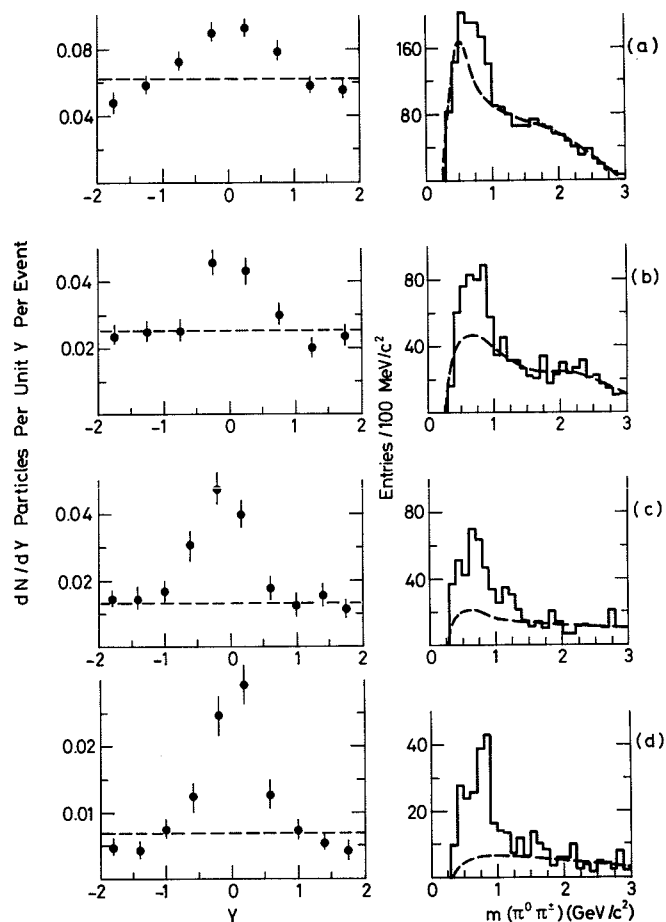

Fig. 10 Rapidity distributions and invariant mass with the  $\pi^0$  trigger for charged towards movers as a function of their  $|p_x|$ : a) 0.4 to 0.6 GeV/c; b) 0.6 to 0.8 GeV/c; c) 0.8 to 1.1 GeV/c; d) 1.1 to 1.7 GeV/c. Data from Ref. 7.

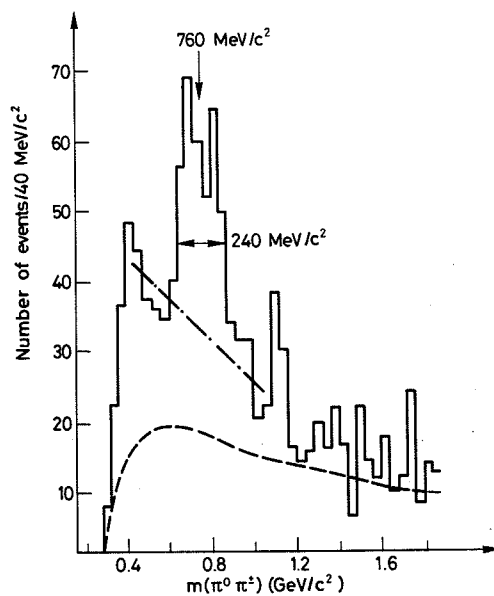

Fig. 11 Charged  $\rho$ -meson production in towards movers. Data from Ref. 7.

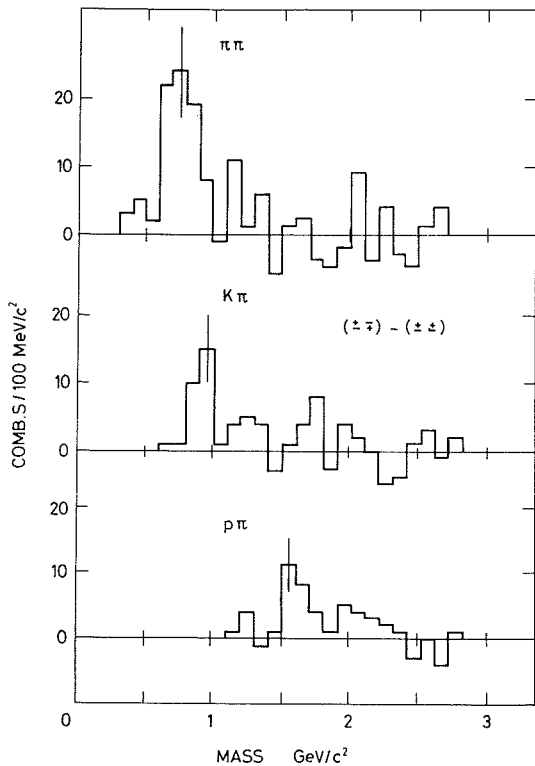

Fig. 12 Invariant mass distribution of towards movers with the large  $p_T$  trigger, from Ref. 12. Double charged pairs have been subtracted from neutral pairs.

around 3.5 GeV/c transverse momentum  $\sigma(\rho^\pm) = (0.9 \pm 0.2)\sigma(\pi^0)$  --  $\rho^0 \rightarrow \pi^+\pi^-$ ,  $K^*(892) \rightarrow K^\pm\pi^\mp$ ,  $N^* \rightarrow p\pi$  (Fig. 12). The observation<sup>7)</sup> of important three-particle correlations among towards movers brings additional support to the idea that two-body resonance decays do not play a dominant role.

### V. The Away Movers

Away movers are at first sight of a different nature in that they cover a wider angular range (Fig. 1) and that their number increases with  $p_T^0$ , typically by 0.8 charged particles per GeV/c. These features were already reported in the earlier experiments<sup>5,6)</sup> and are now confirmed in more recent measurements<sup>7-13)</sup> with the additional information that they depend only little upon the identity of the trigger particle<sup>12,13)</sup>.

Back-to-back momentum correlations<sup>15)</sup> between two pions in the central region are similar to, but even stronger than, those observed in the "alongside" configuration. In particular, they are independent of the charge combination, but, in contrast with the "alongside" case, they do not significantly increase with  $\sqrt{s}$  (Fig. 13).

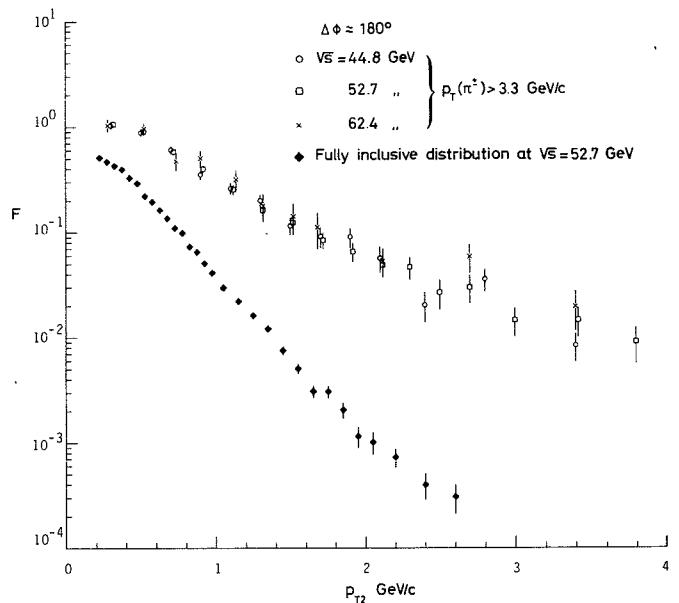

Fig. 13 Momentum correlation function between charged pions for various values of  $\sqrt{s}$  (back-to-back configuration). Data from Ref. 15.

A series of recent experiments<sup>7,11,12)</sup>, where away movers are momentum-analysed in an azimuthal wedge of  $\pm 40^\circ$  opposite to the trigger, show evidence of strong analogies between the away movers and the towards movers. They indeed suggest that away movers are produced with a small transverse momentum relative to the sum of their momenta, which itself covers a wide rapidity domain from event to event, causing the apparent broad coverage of away movers when observed globally. I now review the various evidences in favour of this interpretation.

i) Some azimuthal confinement of the away movers in the vicinity of the scattering plane (which contains the incident momenta and that of the trigger) has been reported<sup>7)</sup>. Defining  $p_x$  and  $p_{out}$ , the components of the transverse momentum  $\vec{p}_T$  of an away mover in and out the scattering plane, the  $p_{out}$  distributions are observed to be independent of  $p_x$ , in contrast with the situation in "normal" events where  $p_{out}$ , on the average, increases with  $|p_x|$ . The mean value of  $p_{out}$  is measured to be 500 MeV/c (Fig. 14).

ii) When studied event by event, away movers are observed to be strongly correlated in rapidity, the stronger the larger  $p_x$ . This has been independently reported by three groups<sup>7,11,12)</sup> and is illustrated in Figs. 15 to 19.



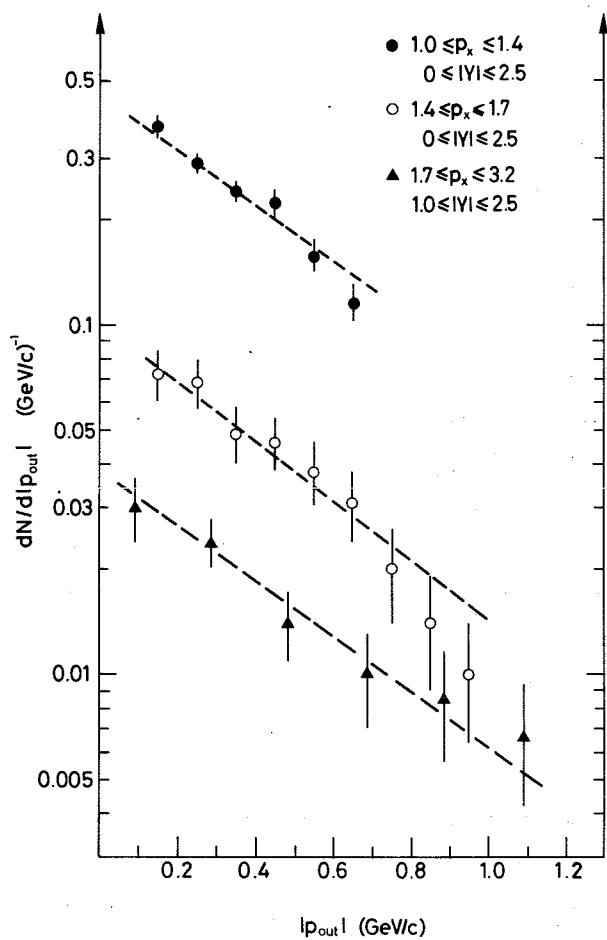

Fig. 14 Distribution in  $p_{out}$  of the away movers in different  $|p_x|$  intervals. Data from Ref. 7.

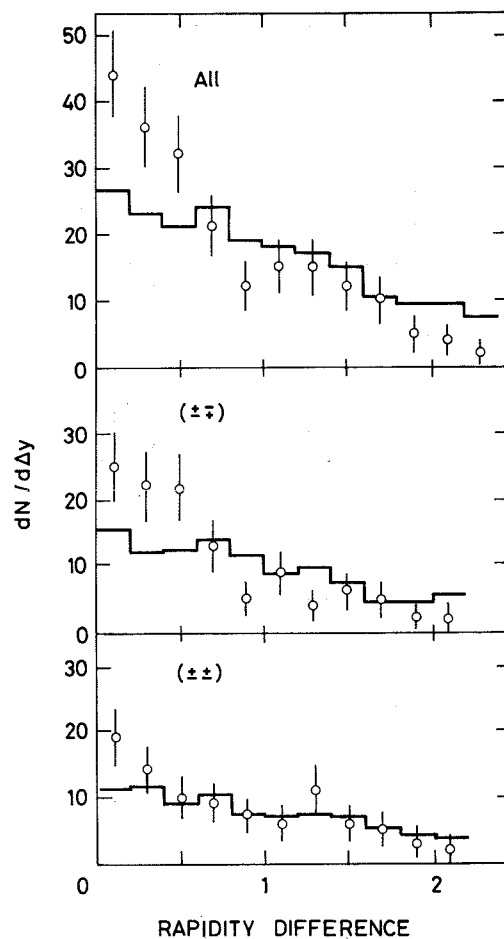

Fig. 16 Rapidity correlation among away movers for different charge combinations. The line indicates the uncorrelated background. Data from Ref. 12.

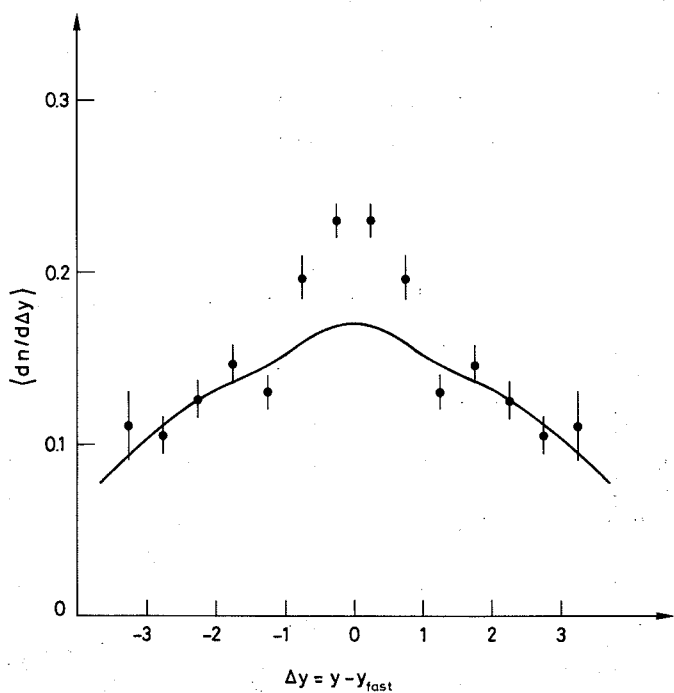

Fig. 15 Rapidity correlation between charged away movers with large  $|p_x|$ . The line indicates the uncorrelated background. Data from Ref. 7.

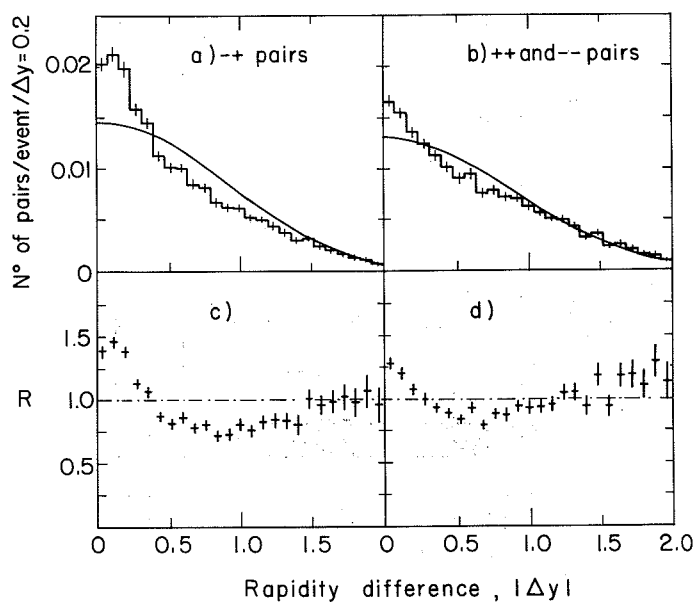

Fig. 17 Rapidity correlation among away movers for different charge combinations. The line indicates the uncorrelated background. Data from Ref. 11.

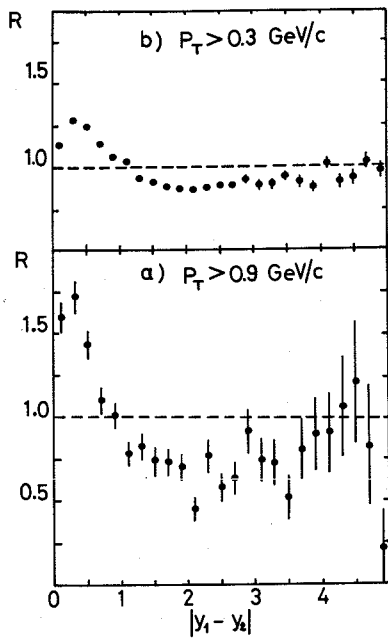

Fig. 18 Rapidity correlation among away movers for two intervals of their transverse momentum. From Ref. 11.

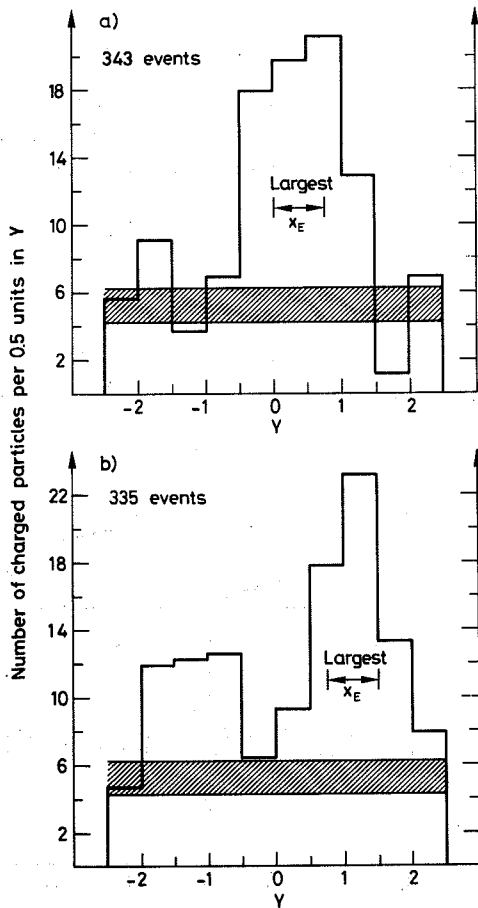

Fig. 19 Rapidity distribution of large  $p_x$  away movers when that with the largest  $p_x$  (not included in the plot) lies in the regions indicated by the arrows. Data from Ref. 7.

For this result to be significant, it must be compared to the similar correlation observed in "normal" events and commonly described in terms of cluster emission. This has been done<sup>7)</sup> for a  $\pi^0$  trigger at  $90^\circ$ , with  $p_T^0 \sim 2.5$  GeV/c, and for secondaries with  $|p_x| > 1.2$  GeV/c (Fig. 15). The observed correlation corresponds to an excess of  $0.33 \pm 0.07$  charged particles per event extending over  $\pm 0.6$  units of rapidity, to be compared with  $0.18 \pm 0.03$  particles per event over  $\pm 0.8$  units of rapidity in "normal" events. The difference is small but significant and the increase of the correlation with  $p_x$  is clearly evidenced (Figs. 18 and 19). Needless to say, higher statistics and larger values of  $p_T^0$  are highly desirable for a better study of the properties of pairs of large  $p_x$  away movers. All three experiments report a larger correlation (by a factor of the order of 2) between opposite charge pairs than between same charge pairs (Figs. 16 and 17).

iii) Distributions in  $p_x$ <sup>7)</sup> are illustrated in Fig. 20. To permit comparison with similar distributions in electroproduction and  $e^+e^-$  annihilation experiments, the variable  $x_e = |p_x|/p_T^0$  is used rather than  $p_x$ . If the trigger itself were the only towards mover, and if the away movers would exactly balance its transverse momentum, the distribution in Fig. 20a would describe the fragmentation of the away movers. But the existence of other towards movers implies that a variable  $x'_e$ , smaller than  $x_e$ , should be used instead. This is done in Fig. 20b and shows no significant effect. Note that, on the average, one quarter of the events have at least 40% of the trigger transverse momentum balanced

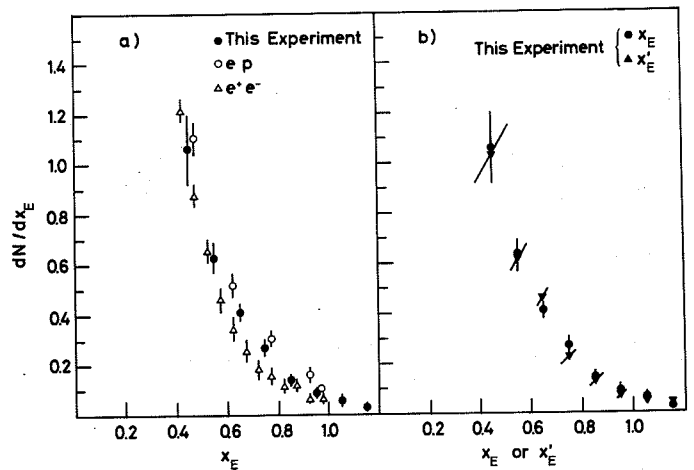

Fig. 20  $dN/dx_e$  distributions for away movers (see text). Data from Ref. 7.

by a single charged particle. The data from Ref. 7 are unfortunately insufficient to study the scaling properties of the  $p_x$  distributions, but in the region ( $p_x > 1.2$  GeV/c,  $|\text{rapidity}| < 2.5$ ,  $|p_{\text{out}}| < 840$  MeV/c) the  $x_e$  distribution is consistent with being independent of  $p_T^0$  for a  $90^\circ \pi^0$  trigger. Preliminary data from Ref. 11, reported by R. Sosnowski at this Conference, however indicate a substantial scaling violation in the region ( $p_x > 1$  GeV/c,  $|p_{\text{out}}| < 850$  MeV/c) for data taken with a charged particle trigger at  $45^\circ$ . It is premature to draw definite conclusions from these possibly contradictory results.

iv) Most experiments do not show any evidence of correlation between the rapidity of the trigger particle and the mean of that of away movers, as further confirmed by recent data<sup>10</sup>). An exception is, however, worth noting. It comes from an experiment<sup>6</sup>) where the secondaries are not momentum-analysed, but where  $p_T^0$  is quite larger than in other data. The trigger is a  $\pi^0$  at rapidity slightly below 1, and the away movers are observed to have an asymmetric rapidity distribution, with an excess of charged particles ( $0.50 \pm 0.12$  charged particles per event in an azimuthal wedge of  $\pm 30^\circ$  opposite to the trigger) towards negative rapidities (Fig. 1).

## VI. Phenomenology of the Event Structure

Without going deeper into the study of large  $p_T$  processes, and in particular before presenting the vast amount of data concerning single-particle inclusive spectra and their dependence upon quantum numbers, it is useful at this stage to attempt to condense the material of the previous sections into a few characteristic properties.

Let us first comment upon the role played by energy-momentum conservation. In the absence of a precise knowledge of the dynamics to which we should apply the  $\delta$ -functions expressing energy momentum conservation, the problem is not well defined. Pure phase space, on the other hand, is so far from measured populations that its study is not very informative. As an exercise, having learned the persistence of longitudinal phase space as a dominant dynamical property, we may study the effect of four-momentum conservation on particles produced independently from each other with uncorrelated transverse momentum

and rapidity distributions adjusted to best fit single-particle inclusive spectra. The main conclusions are as follows:

- i) The transverse momentum of the trigger is balanced by a set of away movers covering a broad angular range, qualitatively similar to what is experimentally observed. However, there are more away movers per GeV/c of  $p_T^0$ , each carrying less transverse momentum, than in the observed data.
- ii) The away movers are not confined to the trigger plane; namely there is little coupling between momenta collinear to the trigger and momenta at  $90^\circ$  in azimuth.
- iii) As expected, not only is there no towards mover, but the particle density on the trigger side decreases slowly with  $p_T^0$ .

These remarks give further support to the idea that only a fraction of the particles in the final state take part in the momentum balance of the large  $p_T$  trigger.

To the extent that the towards and away movers are in close relation with the dynamics of the process of large  $p_T$  production, it is important to analyse their properties independently of the underlying "normal" event. This is very difficult in the present experimental situation where only a few among the away and towards movers have large enough transverse momenta (say  $> 1$  GeV/c) to be distinguished from the underlying "normal" event, acting as a background. This situation, illustrated in Fig. 21, contrasts with that of  $e^+e^-$  annihilation, where there is no

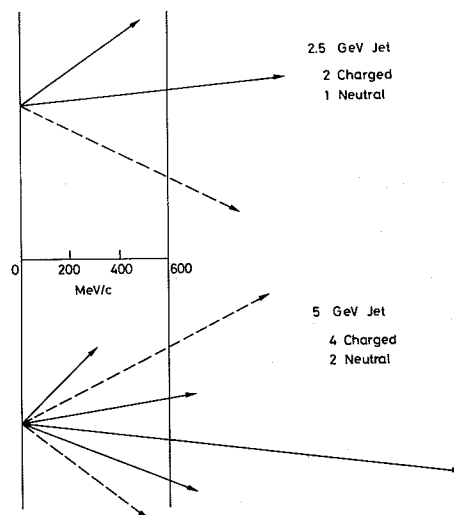

Fig. 21 Scale drawings of typical jets at  $90^\circ$  and "normal" event background. Figure taken from P.V. Landshoff (Ref. 18).

underlying normal event to disturb the analysis of the final hadronic state<sup>16</sup>). A popular and instructive approach<sup>17-22</sup>) has been to postulate some simple properties obeyed by the away and towards movers, and to confront their consequences with experimental data. Let us briefly review and comment upon the hypotheses most commonly postulated. To do so we define

$$\vec{P}^T = \sum_{\text{towards movers}} \vec{p}$$

where the sum includes the trigger particle, and

$$\vec{P}^A = \sum_{\text{away movers}} \vec{p}$$

i)  $\vec{P}^T + \vec{P}^A = 0$ . This hypothesis implies that the underlying normal event has no transverse movement, which is not directly evidenced (at least in this strong form) from the data. In this context, an important comment by Levin and Ryskin<sup>23</sup>) is of relevance. They present cumulative evidence that partons inside hadrons have large transverse momenta, on the average larger than 1 GeV/c. One argument is that the  $p_{\text{out}}$  distribution<sup>7</sup>) presented in a previous section is already quite broad, and corresponds to an even wider transverse momentum distribution for the colliding partons when one accounts for the fact that the observed hadrons carry only a fraction of the momentum of their parent parton. A similar situation is observed in deep inelastic electroproduction<sup>17</sup>). If this were true, the larger  $p_T$  trigger particle would most likely be produced in a collision of two partons with abnormally large transverse momenta in its direction and the above hypothesis should be reconsidered.

$$\text{ii) } E^A E^T \frac{d^6\sigma}{d^3P^A d^3P^T} \approx F(P_T^A) F(P_T^T)$$

This hypothesis of independence upon the rapidities  $y^A$  and  $y^T$ , and of absence of correlation between these two quantities, is believed to be a good approximation in the central region where single-particle inclusive spectra are observed to have the same property and where, for a fixed direction of  $\vec{P}^T$ ,  $\vec{P}^A$  is observed to span a very wide angular range<sup>21</sup>).

iii) In the frame where  $\vec{P}^A + \vec{P}^T = 0$ , let us define the axis J collinear to  $\vec{P}^A = -\vec{P}^T$ . Away and towards movers have transverse momenta  $\hat{p}_T^i$  with respect to this axis and longitudinal momenta  $\hat{p}_L^i$  along this axis. It is commonly postulated that  $\hat{p}_T^i$  are cut off with an average value of the

order of 300 MeV/c and that  $\hat{p}_L^i = x^i \vec{P}^{A,T}$  are distributed according to  $\hat{x}^i dN/d\hat{x}^i = g(\hat{x}^i)$ , where  $g(\hat{x}^i)$  is a smooth function of  $\hat{x}^i$ . This strong hypothesis of Feynman scaling along J is formulated in different manners depending upon the authors. It may be simply postulated<sup>17,18,21</sup>), or based on analogy with other processes such as  $e^+e^-$  annihilation<sup>19,22</sup>) or "normal" hadron-hadron collisions<sup>20</sup>).

The remarkably simple hypotheses mentioned above permit quantitative evaluations of the data. For example, when comparing the momentum correlation between the trigger and away movers with that between the trigger and towards movers, we can weigh the relative importance of the wide angular span of  $\vec{P}^A$  (which depresses the former) and of the distortion on the towards side due to the fact that we trigger on a single particle (which depresses the latter). The agreement with the data is very impressive in view of the simplicity of the hypotheses made. This does not prove that the above picture is the only possible one, nor that it will resist the confrontation with future data -- with hopefully better statistics and larger transverse momenta. It does, however, put severe constraints on possible interpretations of the data. For example, Ellis, Jacob and Landshoff<sup>18</sup>) emphasize the importance of allowing for a small  $\delta$ -function contribution to  $g(\hat{x}^i)$  in the vicinity of  $\hat{x}^i = 1$  in order to obtain good fits to the data. This implies that the set of away movers has a small probability (at the percent level) to consist of a single particle, but on the towards side, because of the peculiar triggering mode, this rare configuration is very much favoured. They find that a form

$$\frac{g(\hat{x}_i)}{\hat{x}_i} \propto \frac{(1 - \hat{x}_i)^2}{\hat{x}_i} + 0.016 \delta(1 - \hat{x}_i)$$

gives an adequate description of the data. A meson-like jet, such as predicted by constituent interchange and quark fusion models, is indeed often expected to consist of a single meson, while a quark-like jet cannot fragment in a single hadron without violating triality conservation. J. and G. Ranft<sup>22</sup>) account for some scaling violation in the jet fragmentation, as observed in the presumably quark-like  $e^+e^-$  jets, and are able to reproduce the experimental situation without the help of a  $\delta$ -function. The same authors note the impossibility of describing the correlation among towards movers with a function  $g(\hat{x}_i)/\hat{x}_i$  decreasing

towards  $\hat{x}_1 = 0$ . Such a situation would arise in the case where away and towards movers would consist each of a large  $p_T$ , low-mass resonance or cluster, such as observed in "normal" events.

Keeping in mind that there is some amount of speculation in the above picture which needs further experimental confirmation, we may already at this stage discard some of the models which have been proposed to describe large  $p_T$  hadronic processes. Single-fireball models<sup>24)</sup>, where the colliding hadrons fuse in a massive hadronic state which subsequently decays isotropically, and bremsstrahlung models<sup>25)</sup>, where the incident hadrons experience a hard scattering and radiate neutral vector mesons, do not account for the presence of an underlying "normal" event with longitudinal phase-space dominance, and, as such, are in disagreement with the data. They do, however (especially the latter), give a satisfactory description of single-particle inclusive spectra and of two-particle momentum correlations.

Hard-scattering quark-parton models where a single meson or meson-resonance is produced on one side, such as the constituent interchange model<sup>26)</sup> and the quark fusion model<sup>27)</sup>, find it difficult to understand the properties displayed by towards movers. For these models to survive, towards movers would have to contain resonances with large multiplicity final states to wash out charge correlations in the "alongside" configuration. It is not clear whether such a situation can be reconciled with present experimental evidence, especially with regard to the above comment of Ranft and Ranft<sup>22)</sup>. It must, however, be noted that the exactly "alongside" configuration does not favour the observation of resonances, and it is very important for future experiments not only to search for resonances among towards movers but also to produce upper limits for their production cross-section in cases where they are not observed.

Multi-fireball models, such as that developed by Kagiya and Hirose<sup>28)</sup>, possess most of the features evidenced in the data. There, one of the clusters in a "normal" event has evolved to a massive excited state, the decay products of which, emitted isotropically in its rest frame, constitute the set of away and towards movers. The fireball must have a sufficiently low multiplicity for energy-momentum conservation within the fireball to fake

the apparent limitation of  $\hat{p}_T^i$ , but a large enough temperature to generate towards movers. Whilst it seems that such a compromise is not excluded, a critical quantitative confrontation with all available data is still to be done. In particular, strong angular correlations between  $\hat{P}^A$  and  $\hat{P}^B$  should apparently be expected in such a picture.

Hard-scattering models, where a binary collision between constituents of the colliding hadrons generates two jets of particles in the final state, are clearly favoured by the data presented in the previous sections. A clear analysis of the experimental situation in these terms has recently been given by Bjorken<sup>17)</sup> who also presents several instructive comparisons with leptoproduction and  $e^+e^-$  annihilation data.

To progress further in our understanding of large  $p_T$  dynamics, it is now time to review the experimental results concerning single-particle inclusive spectra, in particular their scaling properties and their dependence upon quantum numbers.

## VII. Single-Particle Inclusive Spectra

Before the Conference, the experimental material on single-particle inclusive spectra, which has been recently reviewed in detail<sup>29)</sup>, consisted mostly of ISR data<sup>14,15,30)</sup> at rather low values of  $x_T = 2p_T/\sqrt{s}$  and of FNAL data obtained with proton beams on nuclear targets<sup>31,32)</sup>. The main features exhibited by the data may be briefly summarized as follows:

- i) Invariant cross-sections decrease steeply with  $p_T$ , approximately as  $p_T^{-n_{\text{eff}}}$ , with  $n_{\text{eff}} \approx 12$ . In comparison with this strong dependence upon  $p_T$ , that upon  $\sqrt{s}$ , upon angle, and upon particle type are rather mild.
- ii) The dependence upon  $\sqrt{s}$  exhibits violation of Feynman scaling, conveniently expressed in the form  $E(d^3\sigma/dp^3) \propto p_T^{-n} f(x_T)$ , with  $n \approx 8$  in the ISR range. In the FNAL range, when extrapolating the nuclear target data to the p-p case, higher values of  $n$  were obtained at large  $x_T$ , of the order of 11 for pion production<sup>31)</sup>.
- iii) The dependence upon angle is not significant in the central region. In the forward region it is reasonably well accounted for by replacing  $x_T$  by  $x_R = (x_T^2 + x_L^2)^{1/2}$  in the formula above<sup>32)</sup>.

iv) Heavier particles are more copiously produced at larger  $p_T$ . When expressed as a function of  $m_T = (m^2 + p_T^2)^{1/2}$ ,  $m$  being the mass of the particle produced, all cross-sections are similar, within a factor of 5 or so, for  $m$  running all the way from 0.135 to 3.1 GeV/c<sup>2</sup>. The  $\pi^+/\pi^-$  ratio is equal to 1.2, independent of  $p_T$ , in the range explored.

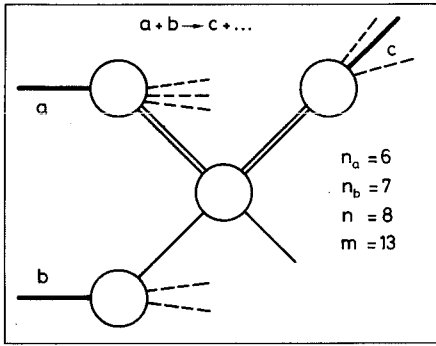

Fig. 22 An illustration of the dimensional counting rules (see text).

These data have been widely analysed and commented upon<sup>29)</sup>, in the frame of quark-parton models, with the help of the powerful and elegant dimensional counting rules<sup>33)</sup> which relate the inclusive cross-section for production of particle  $c$  to the number  $n_a$  of active quark lines taking part in the hard-scattering process and the number  $n_p$  of passive quark lines "wasting" momentum in the hadron  $\leftrightarrow$  quark transitions (Fig. 22). According to the counting rules, one has, in the central region,

$$E(d^3\sigma/dp^3) \propto (p_T^2 + \mu^2)^{-(n_a-2)} f(x_T)$$

with

$$\lim_{x_T \rightarrow 1} f(x_T) = (1 - x_T)^{2n_p-1}.$$

For such arguments to be powerful, they must be confronted with data involving as many particle types as possible, both in the initial and final state, and reaching to large values of  $x_T$ , where valence quarks can be expected to play a major role.

Many such data<sup>34,35)</sup> are contributed to this Conference from FNAL, evidencing the superiority of fixed target machines in the field of single-particle inclusive cross-sections.

The Chicago-Princeton group<sup>35)</sup> have measured invariant cross-sections for the inclusive production of  $\pi^\pm$ ,  $K^\pm$ , and  $p^\pm$  in proton collisions with proton, deuteron, Be, Ti, and

W targets. The data on nuclei will be briefly reported in the next section. An important and unexpected result is that they do not extrapolate accurately to the p-p data. In particular, for pion production, the latter are well described by a form  $p_T^{-n} f(x_T)$ , with  $n = 8.5$  to 8.9, and not 11 as had been previously deduced by extrapolation of nuclear data. The apparent dependence of  $n$  upon  $x_T$ , which was commonly accepted before the Conference, has now disappeared. All measured cross-sections (Figs. 23 to 26) are amenable to a description of the form

$$E(d^3\sigma/dp^3) \propto p_T^{-n} (1 - x_T)^m$$

in the large  $x_T$  region ( $x_T > 0.3$ ). Preliminary fits to the data yield the values of  $n$  and  $m$  listed in Table 2. The  $\pi^+/\pi^-$  ratio, in good agreement with ISR data<sup>15)</sup>, remains at the level of 1.2 to 1.3 in the low  $x_T$  region. But above  $x_T = 0.3$ , where no data exist in the ISR energy range, it abruptly increases and crosses the value of 2 at  $x_T = 0.5$ . The proton and, even more, the antiproton data, are in significant disagreement with ISR measurements in the same kinematic region<sup>30)</sup>.

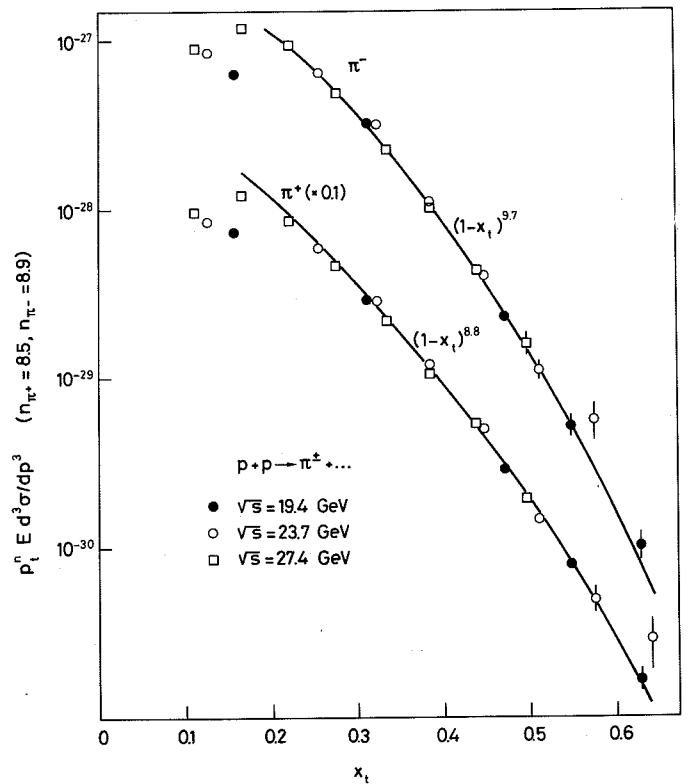

Fig. 23 Scaling in  $\pi^\pm$  production in p-p collisions. Data from Ref. 35.

Table 2

Inclusive channel	n	m	Ref.
$p + p \rightarrow \pi^+ + \dots$	8.5	8.8	35
$p + p \rightarrow \pi^- + \dots$	8.9	9.7	35
$p + p \rightarrow K^+ + \dots$	8.4	8.8	35
$p + p \rightarrow K^- + \dots$	8.9	11.7	35
$p + p \rightarrow p + \dots$	11.7	6.8	35
$p + p \rightarrow \bar{p} + \dots$	11.9	8.0	35
$\pi^- + p \rightarrow \pi^0 + \dots$	-	} $5.5 \pm 0.3$	34
$\pi^+ + p \rightarrow \pi^0 + \dots$	-		34
$p + p \rightarrow \pi^0 + \dots$	-	$7.1 \pm 0.4$	34

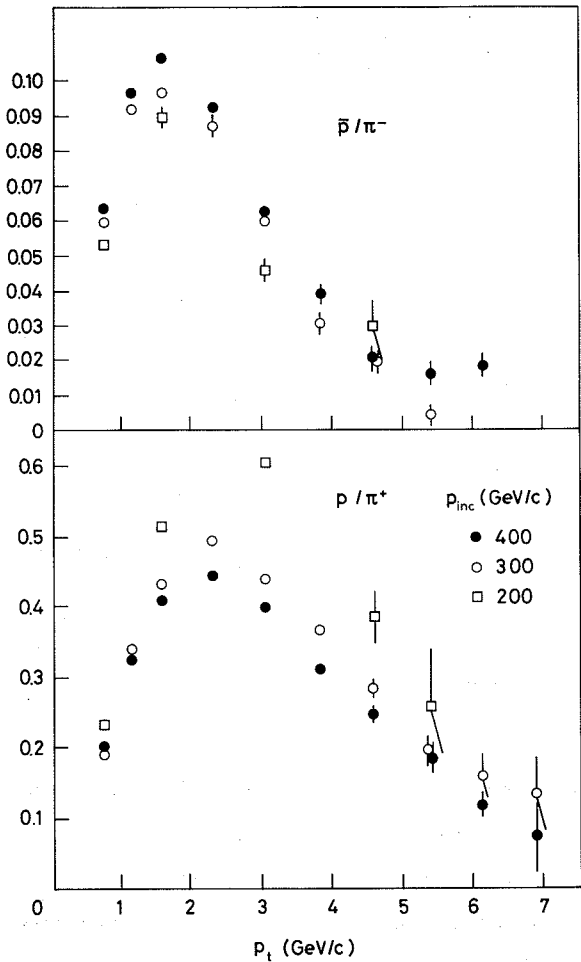

Fig. 24 Antiproton and proton to pion ratios in p-p collisions. Data from Ref. 35.

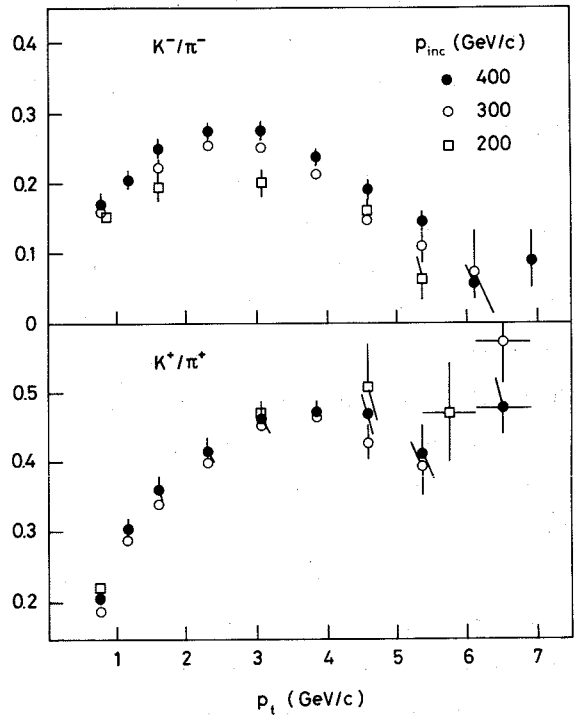
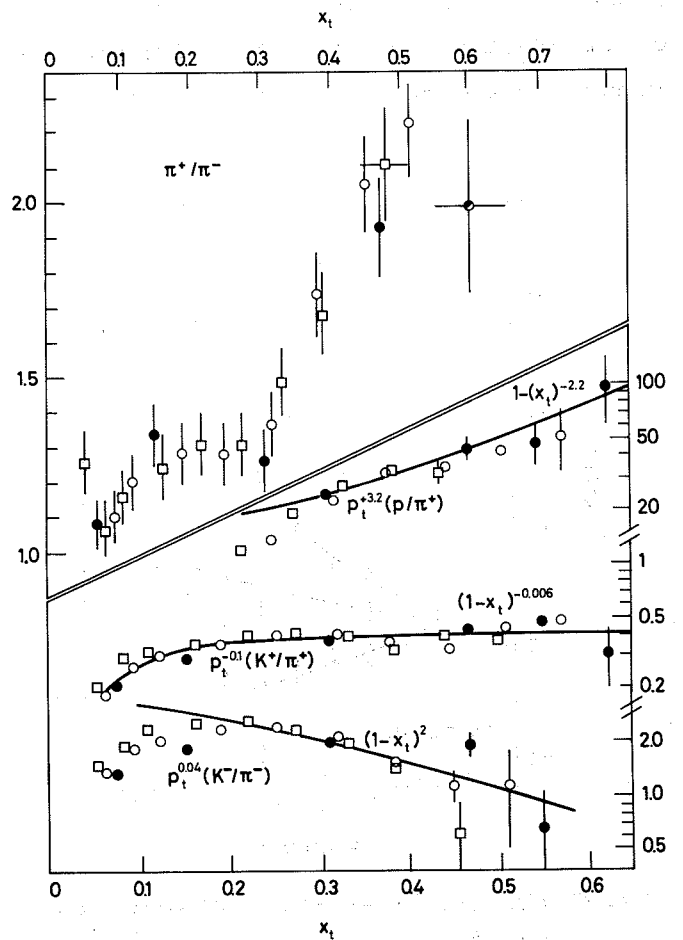

Fig. 25 Kaon to pion ratios in p-p collisions. Data from Ref. 35.

Fig. 26 Particle ratios as a function of  $x_T$  in the Chicago-Princeton data (Ref. 35).  
 Upper figure:  $\pi^+/\pi^-$  ratio (top and left-hand scales).  
 Lower figure:  $p/\pi^+$ ,  $\bar{p}/\pi^-$ ,  $K^+/\pi^+$ , and  $K^-/\pi^-$  ratios multiplied by the scaling power of  $p_T$ .  
 Lines indicate fits to a form  $(1 - x_T)^m$  as indicated on the figure.



The  $\pi^+/\pi^-$  ratio behaves differently in proton-proton collisions and in proton-deuterium collisions (Fig. 27). This may be interpreted as an indication that the  $\pi^+/\pi^-$  ratio is roughly equal to 1, independent of  $p_T$ , in proton-neutron collisions. Such a conclusion, obtained by simply subtracting the proton value from the deuterium value, may however seem hazardous in the present situation.

The BNL-CalTech-LBL group<sup>34)</sup> presents measurements of inclusive  $\pi^0$  production at  $90^\circ$  from  $\pi^\pm$ -p and p-p interactions at 100 and 200 GeV/c. They are the first measurements of that kind performed with a meson beam, and will hopefully be followed by a long succession of similar experiments. The lever arm in s is not sufficient to permit a meaningful study of the scaling behaviour of the measured cross-sections. However, the  $p_T$  dependences at fixed  $x_T$  are observed to be sufficiently similar to study cross-section ratios as a function of  $x_T$ . The  $\pi^+$ -p  $\rightarrow \pi^0 + \dots$  and  $\pi^-$ -p  $\rightarrow \pi^0 + \dots$  cross-sections are equal within errors over the full  $p_T, \sqrt{s}$  range (Fig. 28). The ratio R between the p-p  $\rightarrow \pi^0 + \dots$  and  $\pi^-$ -p  $\rightarrow \pi^0 + \dots$  cross-sections is displayed in Fig. 29 as a function of  $x_T$ , and varies like  $(1 - x_T)^m$  with  $m = 1.6 \pm 0.5$ . The systematic uncertainty on these ratios, where the numerator and the denominator are measured with the same detector but in different beams and runs, is claimed by the authors to be very small.

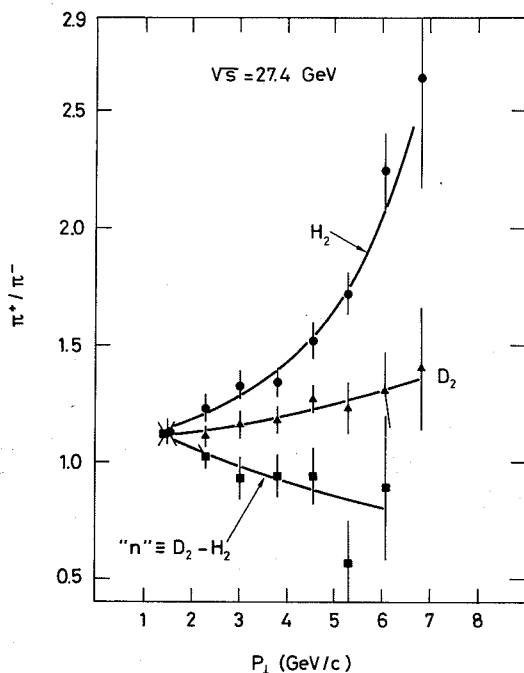

Fig. 27  $\pi^+/\pi^-$  ratio in p-p and p-d collisions. From Ref. 35.

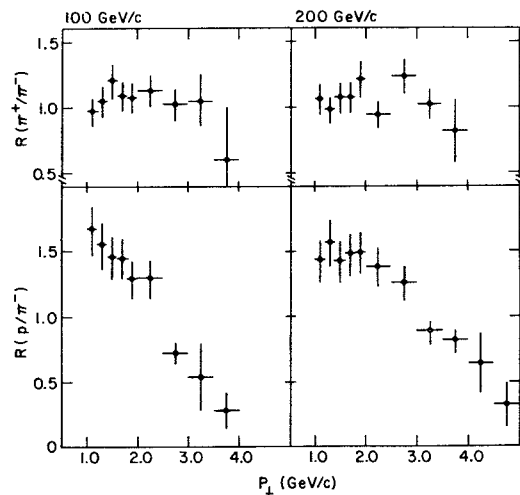

Fig. 28 Ratios between  $\pi^+$ -p  $\rightarrow \pi^0 + \dots$  and  $\pi^-$ -p  $\rightarrow \pi^0 + \dots$  (upper figures), and between p-p  $\rightarrow \pi^0 + \dots$  and  $\pi^-$ -p  $\rightarrow \pi^0 + \dots$  (lower figures) for two values of  $\sqrt{s}$ . Data from Ref. 34.

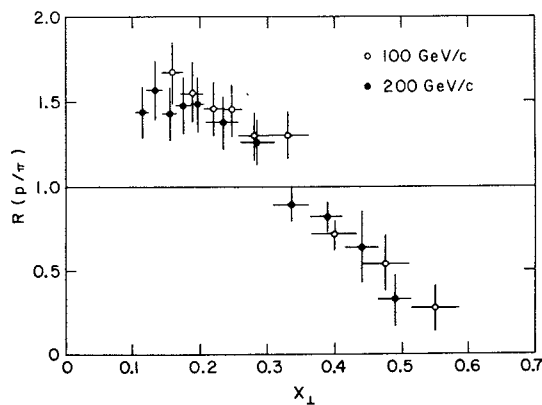

Fig. 29 Ratio between p-p  $\rightarrow \pi^0 + \dots$  and  $\pi^-$ -p  $\rightarrow \pi^0 + \dots$  as a function of  $x_T$  (Ref. 34).

Preliminary data at forward angles ( $\approx 35^\circ$ ) indicate a similar behaviour.

I conclude this section on single-particle inclusive spectra by briefly mentioning four other contributions to this Conference.

The first one<sup>36)</sup> concerns the production of  $\pi^0$  at  $90^\circ$  in the ISR energy range, and differs from previous measurements in that the  $\pi^0$  is identified from its  $\pi^0 \rightarrow \gamma\gamma$  decay mode. In the range  $1.6 < p_T < 3.8$  GeV/c the data agree well with  $\pi^\pm$  cross-sections<sup>30)</sup> within the 20% normalization uncertainty between the two experiments.

The second<sup>37)</sup> is a measurement of the charge asymmetry in the central region in  $\bar{p}$ -p interactions at 22.4 GeV/c incident momentum. The charge asymmetry is observed to occur in the forward and backward directions close to the



central region and to increase with transverse momentum. A similar observation is reported<sup>38)</sup> in 16 GeV/c  $\pi^\pm$ -p and 100 GeV/c  $\pi^-$ -p interactions by another collaboration, who present in addition<sup>39)</sup> a very rich set of data on inclusive production of many resonances which are all observed to have a similar  $p_T$  dependence in the larger  $p_T$  region.

### VIII. Nuclear Effects

The early measurements<sup>31)</sup>, by the Chicago-Princeton Collaboration, of large  $p_T$  inclusive spectra from proton-nucleus collisions had triggered much interest<sup>40)</sup> in that the atomic number dependence was observed to behave like  $A^\alpha$  with  $\alpha \gg 2/3$ , even greater than 1.

The same Collaboration reports on similar measurements<sup>35)</sup>, but with higher statistics and better control upon systematic uncertainties. In the case of  $\pi^\pm$  production the power  $\alpha$  shows a clear tendency to decrease towards very large values of  $p_T$ , after having reached a maximum (slightly above 1.1) at  $p_T = 4$  to 5 GeV/c (Fig. 30).

New data<sup>41)</sup> from Serpukhov on large  $x_T$  (0.2 to 0.6) inclusive yields at 90° from p-Be and p-Cu collisions (70 GeV/c incident momentum) are presented. The  $K^+/\pi^+$  and  $p/\pi^+$  ratios are observed to behave in a similar way to those in the FNAL energy range.

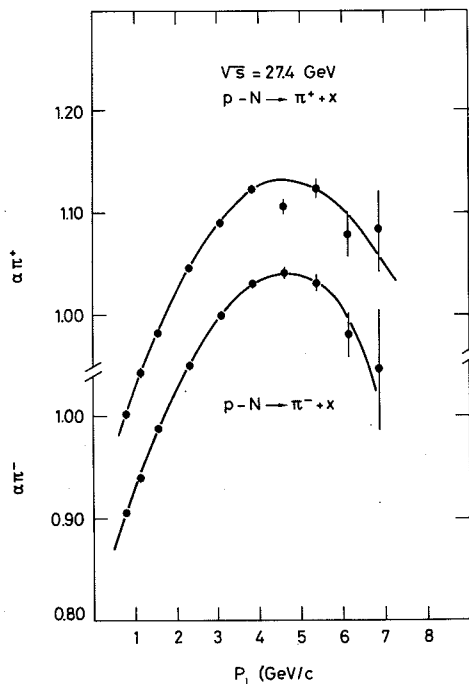

Fig. 30 Atomic number dependence of inclusive  $\pi^\pm$  production in proton-nucleus collisions (Ref. 35). The exponent  $\alpha$  of the atomic number  $A$  is displayed as a function of  $p_T$ .

### IX. More on Models

When considered together, the experimental material on the structure of large  $p_T$  events and that on single-particle inclusive spectra sum up to a large amount of information which has generated much activity among theorists. I am not competent to give a critical evaluation of their many contributions to the Conference, and can only extract from their work the points which seem to me relevant for guiding experimentalists in their measurements.

A central question concerns the understanding of the depression of the Berman-Bjorken-Kogut (BBK) diagram<sup>2)</sup> (gluon exchange between quarks, Fig. 31a). As is immediately apparent from the dimensional counting rules, this corresponds to  $n = 4$ , while the data want  $n \approx 8$  (for  $p-p \rightarrow \pi + \dots$ ). Before the Conference, when  $n$  was believed to be different in the ISR and FNAL energy ranges, we might have seen in the data a trend for  $n$  to decrease towards larger values of  $s$ , and speculate that it might level off at very high energies. This is no longer reasonable. As an illustration of current ideas on the problem, I briefly list a few representative models which have been proposed.

1) The constituent interchange model<sup>26)</sup> postulates the depression of the BBK diagram and assumes the dominance of subprocesses involving hadrons as constituents, such as quark-meson scattering (Fig. 31b). Depending upon the  $(x_T, p_T)$  domain, several such processes may be at work according to the respective dominance of the  $p_T^{-n}$  and  $(1 - x_T)^m$  terms. This results in much flexibility built up into the model, which appears to reproduce successfully most of the scaling behaviour of single-particle inclusive distributions. In addition, it offers a natural smooth connection to exclusive processes as well as to low  $p_T$  reactions, and provides a good description of form factors. Its most recent developments have been reported by S. Brodsky at this Conference, together with a comparison of its predictions with the new FNAL results presented above. The main merit of this model may be to offer a transparent recipe for immediately deducing from the data which are the dominant subprocesses, and possibly providing some hint towards a better understanding of the dynamics. A recent example is the possible importance of minimum neutralization of quark lines<sup>42)</sup>.

2) The quark fusion model<sup>27)</sup> is of a similar nature (Fig. 31c). The dominant process is postulated to be

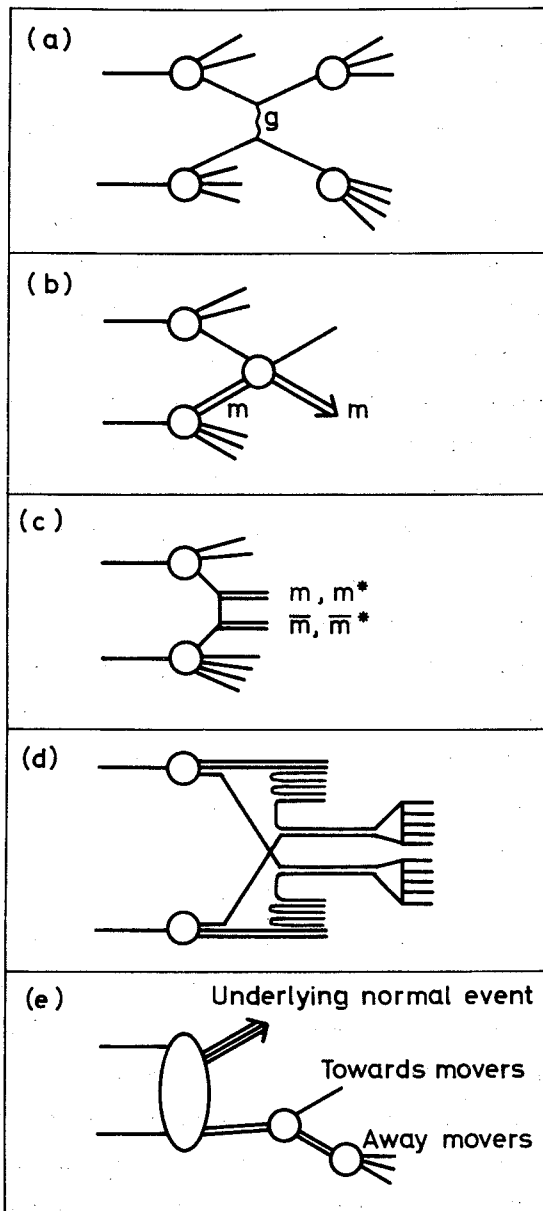

Fig. 31 Some typical diagrams of current parton models (see text).

quark + antiquark  $\rightarrow$  two mesons, which corresponds to  $n = 8$ .

As previously mentioned, such models do not account for the production of apparently non-resonant towards movers.

An *ad hoc* modification has recently been proposed<sup>43)</sup> by replacing the outgoing mesons by meson-like jets. An interesting consequence<sup>44)</sup> is the prediction of a copious single-photon yield (the lesser electromagnetic coupling being compensated by the absence of fragmentation). A recent ISR experiment<sup>36)</sup> indeed reports the observation of large  $p_T$  photons at  $90^\circ$  ( $3 < p_T < 4$  GeV/c) in excess of the  $\pi^0 \rightarrow \gamma\gamma$  and  $\eta \rightarrow \gamma\gamma$  contributions. The ratio  $R = \sigma(p-p \rightarrow \gamma + \dots) / \sigma(p-p \rightarrow \pi^0 + \dots)$  is measured to be  $(20 \pm 10)\%$ , where the error includes several systematic

uncertainties (Fig. 32). In the framework of quark fusion models, much effort has been devoted to describing, in a unified manner, high and low  $p_T$  processes at all angles<sup>45)</sup>. A summary of such work has been given by T. Matsuoka at this Conference. Most features of the data are successfully described by assuming multiperipheral dynamics for the jet fragmentation (Fig. 31d). A feature of the model, which has to be revised, is to predict an increase of  $n$  with  $x_T$ , similar to what was commonly believed before the Conference.

3) In the massive quark model<sup>19)</sup>, free quark states are explicitly avoided by setting quark masses to a large value and by strongly damping quark scattering amplitudes at large masses in order to prevent the appearance of on-mass-shell quarks. An  $n = 4$  subprocess is present, but in the FNAL-ISR energy range the dominant subprocess (Fig. 31e) corresponds again to  $n = 8$  for inclusive meson production. A small-mass cluster (towards movers) recoils against a larger mass hadronic state (away movers), which decays with limited transverse momentum and Feynman scaling along its axis. As previously mentioned, this model reproduces well the many aspects of the event structure.

4) Some authors maintain the dominance of the BBK subprocess by introducing a scale at its vertex<sup>23)</sup>. A recent comment along this line<sup>46)</sup> has been made in relation to the scaling violation apparently observed in deep inelastic lepton production. From a description of  $\nu W_2$  in the form

$$\nu W_2 = f(x)(1 + q^2/\Lambda^2)^{-2}$$

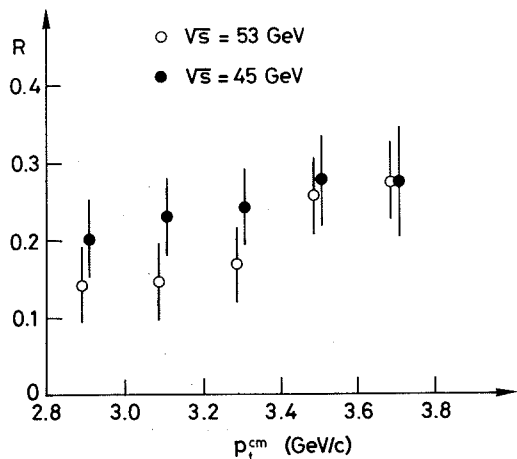

Fig. 32 Ratio between photon and  $\pi^0$  cross-sections in p-p collisions (the  $\pi^0 \rightarrow \gamma\gamma$  and  $\eta \rightarrow \gamma\gamma$  contributions have been subtracted from the photon component). An additional 7% uncertainty must be applied to the data (Ref. 36).

which reproduces the experimental data for  $\Lambda^2 \approx 50$  (GeV/c)<sup>2</sup>, it is possible to infer an effective finite quark size and calculate the modified inclusive cross-sections. It is of course questionable whether such an extrapolation is reasonable, but it results in a beautiful agreement with the pion data.

5) I conclude this list by mentioning the field theoretical approaches<sup>47)</sup> which have been reviewed by A.N. Tavkhelidze, A.V. Efremov and L.A. Slepchenko at this Conference. Kvinikhidze et al.<sup>47)</sup>, starting from field theoretic arguments for composite hadrons, obtain a number of general conclusions which reduce to the usual parton-model results under the more specific assumptions inherent to such models. In particular, they give a general derivation of the dimensional counting rules. Their treatment of the rescattering<sup>48)</sup> of the hard scatters in the stream of the passive constituents of the colliding hadrons is of particular interest. Similar ideas have been considered by Gasser and Sukhatme<sup>20)</sup> in a purely phenomenological and *ad hoc* manner, with much success in describing the main properties of the event structure.

It is clearly premature and outside my competence to give a critical analysis of the implications of the new FNAL data on current models. The remarkable agreement of the Chicago-Princeton<sup>35)</sup> cross-sections with a form  $p_T^{-n} (1 - x_T)^m$  over a wide range of  $x_T \geq 0.3$  nonetheless indicates that their analysis will be more informative than before. A few simple and possibly naive comments can already be made at this stage.

The data of Donaldson et al.<sup>34)</sup> suggest that the presence of an antiquark in the pion wave function is not as important as might have been anticipated, although pions appear to be more efficient than protons at producing  $\pi^0$ 's in collisions with protons. If the dominant subprocesses would directly involve the antiquark from the incident pion, we would naively expect

$$R_\pi = \frac{\pi^+ - p \rightarrow \pi^0 + \dots}{\pi^- - p \rightarrow \pi^0 + \dots} = \frac{1}{2}$$

$$R_p = \frac{\pi^\pm - p \rightarrow \pi^0 + \dots}{p - p \rightarrow \pi^0 + \dots} \propto (1 - x_T)^{-6}.$$

The data rather favour subprocesses where, for example, a pion constituent of the incident pion takes part in the hard scattering, in which case  $R_\pi \approx 1$  and  $R_p \propto (1 - x_T)^{-2}$ . These remarks are not in favour of the quark fusion model.

In the constituent interchange model we expect dominant subprocesses with  $n = 8$  for meson production, and  $n = 12$  for  $p^\pm$  production, in good agreement with experiment. This seems to be difficult to reconcile with quark-quark scattering subprocesses, which would, in addition, predict much higher values of  $m$  than experimentally observed in  $p^\pm$  production because of the necessity of having a large number of spectators. Another difficulty for quark-quark scattering models, previously noted by Bjorken<sup>17)</sup>, is the non-equality of the  $p/\bar{p}$  and  $K^+/K^-$  ratios in p-p collisions. The new data confirm the relation

$$\left( \frac{p}{K^+} / \frac{\bar{p}}{K^-} \right) \approx 4 \quad \text{at } p_T = 3 \text{ GeV}.$$

The observed increase of the  $\pi^+/\pi^-$  ratio in p-p collisions, up to and possibly above 2, is however a relief for most quark-parton models, which had difficulty in understanding the stable value of 1.2 obtained below  $x_T = 0.3$ .

Many more measurements are clearly necessary in order to understand the dynamics of large  $p_T$  collisions and the respective roles of constituent interchange and quark-quark scattering subprocesses<sup>49)</sup>, the former being successful at explaining single-particle inclusive spectra, the latter at understanding the global structure of the event. In the guise of a conclusion, we may try to single out some experiments which should shed some light on these questions.

## X. Conclusion

Data of the quality of the Chicago-Princeton measurements<sup>35)</sup> must be collected on hydrogen at large  $x_T$  with various incident beams ( $\pi^\pm, K^\pm, \gamma$ ), looking for  $p^\pm, \pi^\pm$ , and  $K^\pm$  inclusive spectra. The accelerators at FNAL, and in the near future at the CERN SPS, are best suited for such studies.

The exact nature of away and towards movers must be further investigated. Their apparent jet structure has to be confirmed in experiments with larger  $p_T$  triggers and better statistics to permit detailed studies of the shape and scaling properties of the transverse and longitudinal momentum distributions along the jet axis. In addition, the exact role played by resonances should be understood.

Angular correlations between leading away and towards movers are very informative<sup>49)</sup>. Very little is at present known at large enough  $p_T$ .

Quantum number flow, both within the set of away and towards movers, and between it and the underlying normal event, are predicted to behave very differently in different models. Their study, at large values of  $x_T$ , would give precious information.

The very same studies should be performed with  $e^+e^-$  hadronic final states, which are believed to be pure quark-like jets, undisturbed by the cumbersome background of the underlying normal event in hadron-hadron collisions. Much understanding will undoubtedly emerge from a detailed comparison between  $e^+e^-$  jets and the final states of large  $p_T$  hadronic processes.

#### Acknowledgements

I am very much indebted to Stan Brodsky for a critical reading of the manuscript and many suggestions for improvements.

I am grateful to Leonid Slepchenko and George Vesztergombi for their constant and friendly help during the Conference.

#### References

- 1) S.M. Berman and M. Jacob, Phys. Rev. Letters 25, 1683 (1970).
- 2) S.M. Berman, J.D. Bjorken and J.B. Kogut, Phys. Rev. D 4, 3388 (1971).
- 3) T.T. Wu and C.N. Yang, Phys. Rev. 137, B708 (1965).
- 4) B. Alper et al., Phys. Letters 44B, 521 (1973).  
M. Banner et al., Phys. Letters 44B, 537 (1973).  
F.W. Büsser et al., Phys. Letters 46B, 471 (1973).
- 5) G. Finocchiaro et al., Phys. Letters 50B, 396 (1974).
- 6) K. Eggert et al., Nuclear Phys. B98, 73 (1975).
- 7) P. Darriulat et al., Nuclear Phys. B107, 429 (1976).
- 8) M. Della Negra et al., Phys. Letters 59B, 401 (1975).
- 9) M. Della Negra et al., Nuclear Phys. B104, 365 (1976).
- 10) M. Della Negra et al., General characteristics of p-p collisions in which a high transverse momentum particle is produced, Paper 127/A4-14 contributed to this Conference.
- 11) M. Della Negra et al., Study of jet structure in p-p collisions with large transverse momentum secondaries, Paper 129/A4-15 contributed to this Conference.
- 12) British-Scandinavian-French Collaboration, Preliminary data presented orally at this Conference.
- 13) B. Alper et al., Multiplicities associated with the production of pions, kaons or protons of high transverse momentum at the ISR, Rutherford Laboratory preprint RL-76-031 (1976).  
G. Bellettini et al., Correlation studies of events with a charged hadron at  $x = 0$  in proton-proton collisions at the CERN ISR, Paper 114/A2 contributed to this Conference.
- 14) K. Eggert et al., Nuclear Phys. B98, 49 (1975).
- 15) F.W. Büsser et al., Nuclear Phys. B106, 1 (1976).
- 16) G. Hanson et al., Phys. Rev. Letters 35, 1609 (1975); and, Evidence for jet structure in hadron production by  $e^+e^-$  annihilation, Talk delivered at the SLAC Summer Institute on Particle Physics, July 1975.
- 17) J.D. Bjorken, High  $p_T$  dynamics, Lectures delivered at the SLAC Summer Institute on Particle Physics, July 1975.
- 18) S.D. Ellis, M. Jacob and P.V. Landshoff, Nuclear Phys. B108, 93 (1976).  
P.V. Landshoff, Jets in large  $p_T$  reactions, Talk presented at the XIth Rencontre de Moriond, Flaine, 1976.
- 19) G. Preparata and G. Rossi, Looking at hadronic final states at high energies, I. Phenomena at large  $p_T$ , CERN preprint TH 2163, 5 May 1976; and, Paper 712/A4-16 contributed to this Conference.
- 20) J. Gasser and W.P. Sukhatme, The origin of jets, University of Cambridge preprint DAMP 76/3, January 1976.
- 21) W. Furmanski and J. Wosiek, Correlations in large  $p_T$  processes in parton models, Jagellonian University preprint TPJU 7/76, March 1976; and, Paper 1106/A4-30 contributed to this Conference.  
W. Furmanski and J. Wosiek, Parton-parton interaction derived from large  $p_T$  data, Jagellonian University preprint TPJU 13/76, June 1976.
- 22) J. Ranft and G. Ranft, Large transverse momentum correlations on the same hemisphere and realistic jets, Karl-Marx University preprint KMJ-HEP 7604, January 1976; Rapidity distributions of large  $p_T$  particles and realistic jets, Karl-Marx University preprint KMJ-HEP 7610, April 1976; and, Paper 396/A4-24 contributed to this Conference.
- 23) E.M. Levin and M.G. Ryskin, How large is the average transverse momentum of partons? Is it larger than 1 GeV/c?, Leningrad Nuclear Phys. Inst. preprint No. 167, July 1975; and, Paper 1005/A4-2 contributed to this Conference.  
E.M. Levin and M.G. Ryskin, Production of hadrons with large transverse momentum and interaction of partons, Paper 884/A4-1 contributed to this Conference.
- 24) Meng Ta-Chung, Phys. Rev. D 9, 3062 (1974).  
Kwan-Wu Lai and Meng Ta-Chung, Statistical approach to large  $p_T$  phenomena in meson-nucleon and nucleon-nucleon collisions, Stony Brook preprint ITP-SB-76-22, March 1976; and, Paper 977/A4-25 contributed to this Conference.

- 25) A.P. Contogouris, J.P. Holden and E.N. Argyres, Phys. Letters 51B, 251 (1974) and Nuclear Phys. B85, 102 (1975).  
D. Schiff, A.P. Contogouris and J.L. Alonso, Phys. Letters 55B, 87 (1975).  
A.P. Contogouris, private communication.
- 26) J.F. Gunion, S.J. Brodsky and R. Blankenbecler, Phys. Letters 39B, 649 (1972); Phys. Rev. D 6, 2652 (1972); Phys. Letters 42B, 461 (1973); Phys. Rev. D 8, 287 (1973).
- 27) P.V. Landshoff and J.C. Polkinghorne, Phys. Rev. D 8, 4159 (1973); Phys. Letters 45B, 361 (1973); Phys. Rev. D 8, 927 (1973).
- 28) S. Kagiyama and T. Hirose, Progr. Theor. Phys. 54, 1226 (1975); and, Superconductive fireball model on large  $p_T$  phenomena, I, II, and III, Kagoshima Univ. preprints KAGOSHIMA EP-002, 003, and 004 (1976).
- 29) D. Sivers, S.J. Brodsky and R. Blankenbecler, Phys. Rep. 23C, 1 (1976).
- 30) B. Alper et al., Nuclear Phys. B87, 19 (1975) and Nuclear Phys. B100, 237 (1975).
- 31) J.W. Cronin et al., Phys. Rev. D 11, 3105 (1975).
- 32) D.C. Carey et al., Inclusive  $\pi^0$  production by high-energy protons, FERMILAB-Pub-75/75-EXP 7100.063, to be published in Phys. Rev.
- 33) S.J. Brodsky and G.R. Farrar, Phys. Rev. Letters 31, 1153 (1973) and Phys. Rev. D 11, 1309 (1975).  
V. Matveev, R. Muradyan and A. Tavkhelidze, Nuovo Cimento Letters 7, 719 (1973).
- 34) G. Donaldson et al., Phys. Rev. Letters 36, 1110 (1976); and, Inclusive  $\pi^0$  production at large transverse momentum for  $\pi^\pm$ -p and p-p interactions at 100 and 200 GeV/c, Paper 746/A4-27 contributed to this Conference.
- 35) D. Antreasyan et al., A precise comparison of hadron production at large  $p_T$  in 200, 300, and 400 GeV proton collisions with proton, deuteron, and nuclear targets, Paper 753/A4-17 contributed to this Conference.
- 36) P. Darriulat et al., Large transverse momentum photons from high-energy proton-proton collisions, Paper 341/A4-28 contributed to this Conference.
- 37) Alma Ata-Dubna-Helsinki-Košice-Moscow-Prague Collaboration, Charge asymmetry at large  $p_T$  in inelastic  $\bar{p}$ -p reactions at 22.4 GeV/c, Paper 903/A4-8 contributed to this Conference.
- 38) Aachen-Berlin-Bonn-CERN-Cracow-Heidelberg-Warsaw Collaboration, Studies of events with a secondary of high transverse momentum in 16 GeV/c  $\pi^\pm$ -p and 100 GeV/c  $\pi^-$ -p collisions, Paper 898/A4-20 contributed to this Conference.
- 39) Aachen-Berlin-Bonn-CERN-Cracow-London-Vienna-Warsaw Collaboration, Inclusive yields and transverse spectra of pions and meson resonances and study of "direct" pion production, Paper 905/A4-23 contributed to this Conference.
- 40) G.B. Alaverdian, A.V. Tarasov and V.V. Uzinsky, Mass number dependence of proton spectra with large transverse momentum in proton-nucleus collisions, Dubna preprint E2-9606 (1976); and, Paper 1014/A6-60 contributed to this Conference.  
G.R. Farrar, Phys. Letters B56, 185 (1975).  
N.N. Nikolaev and V.I. Zakharov, Parton model and inelastic scattering of leptons and hadrons off nuclei, Moscow, 21 March 1975.
- 41) S.A. Akimenko et al., A study of relative hadronic yields at large transverse momentum from 70 GeV/c p-nucleus collisions, Paper 1225/A4 contributed to this Conference.
- 42) S.J. Brodsky, Constituent models and large transverse momentum reactions, SLAC preprint SLAC-PUB-1733, April 1976 (lecture delivered at the 1975 SLAC Summer Institute).
- 43) B.L. Combridge, Phys. Letters 62B, 222 (1976).
- 44) C.O. Escobar, Direct production of photons with large transverse momentum in proton-proton collisions, Cambridge preprint DAMTP 76/6 (1976).  
G.R. Farrar and S.C. Frautschi, Phys. Rev. Letters 36, 1017 (1976).
- 45) Y. Kinoshita and K. Kinoshita, Unified description of large and small  $p_T$  spectra in p-p collisions at PS and ISR energies, Bielefeld preprint BI-TP 76/5, February 1976.  
K. Kinoshita, A model of multiparticle final states in hadronic and current-induced reactions, Bielefeld preprint BI-TP 76/6, March 1976.  
T. Matsuoka and S. Sawada, Transverse momentum in the multiple production processes, Paper 896/A4-18 contributed to this Conference.  
Y. Igarashi, T. Matsuoka and S. Sawada, Large  $p_T$  hadron production and urbaryon rearrangement model, Paper 897/A4-19 contributed to this Conference.  
S. Matsuda, Phys. Rev. D 12, 1940 (1975); and, Paper 997/A4-9 contributed to this Conference.  
J. Kodaira and S. Matsuda, Progr. Theor. Phys. 55, 770 (1976); and, Paper 998/A4-10 contributed to this Conference.  
J. Kodaira and S. Matsuda, Two-way quark cascade and particle ratios in  $\gamma + p \rightarrow h^\pm + \text{anything}$ , Kyoto preprint KUNS 325 HE(TH) 75/12; and, Paper 999/A4-11 contributed to this Conference.  
J. Kodaira and S. Matsuda, Meson-baryon and baryon-antibaryon ratios in two-way quark cascade model, Kyoto preprint KUNS 341 HE(TH) 76/1; and, Paper 1000/A4-12 contributed to this Conference.

- 46) R.C. Hwa, A.J. Spiessbach and M.J. Tepper, Connection between scale breaking in deep inelastic processes and large  $p_T$  hadronic reactions, Paper 900/A4-22 contributed to this Conference; and, Phys. Rev. Letters 36, 1418 (1976).
- 47) A.N. Kvinikhidze et al., Production properties at high  $p_T$  in a composite particle approach, Paper 1081/A4-31 contributed to this Conference.  
A.V. Efremov, Dynamics of processes with large transverse momenta, Paper 894/A4-5 contributed to this Conference.
- 48) A.N. Kvinikhidze and L.A. Slepchenko, JINR preprint P1,2-8529 (1975), to be published in Nuclear Physics.
- 49) R. Raitio, Large  $p_T$  hadron physics: gluon or quark exchange, Univ. Wisconsin preprint COO-545, April 1976.