

Upgrade of the Readout Electronics of the ATLAS MDT Detector for SLHC

R. Richter^a,
S. Horvat^a, O. Kortner^a, H. Kroha^a, F. Legger^a, F. Rauscher^b

^a Max-Planck-Institut für Physik, München, Germany

^b Ludwig-Maximilian-Universität, München, Germany

richterr@mppmu.mpg.de

Abstract

Simulation predicts a high level of ionizing radiation in the ATLAS experimental hall during LHC operation. This radiation will act as a source of background signals to the four subsystems of the ATLAS muon detector. We present the performance of the Monitored Drift Tube detector (MDT) under these background conditions and discuss the consequences for the much higher background rates at SLHC with respect to tracking efficiency, resolution and readout bandwidth. For rates beyond the expected LHC levels, we discuss options to improve the performance of detector and electronics.

I. INTRODUCTION

The MDT chambers form the outermost part of the ATLAS experiment and are designed to measure the position of tracks with a precision of about $80 \mu\text{m}$. MDT chambers are arranged in layers, in such a way as to measure the coordinates of each track at three locations along its trajectory, allowing to determine its momentum from the curvature in the magnetic field. The MDT chamber layers form three concentric cylinders around the beam axis in the central part of the detector and three wheel-like structures in the forward and backward part. A detailed presentation of the muon system and of the MDT readout electronics is given in [1] and [2], respectively.

As the calorimeters in the central part absorb most hadrons, electrons and γ 's, only muons will penetrate into the outer region and only an average of about 1.5 muons above 6 GeV are expected in any triggered event. Thus, only a small number of chambers (out of 1200) contains tracking information in any given event.

Most of the MDT chambers are matched by a corresponding trigger chamber. These chambers use the RPC and TGC technology in the barrel and end-cap region, respectively. Compared to the MDT, trigger chambers are less precise in measuring the track position, but have much better time resolution (10–15 ns), which allows tagging of the beam crossing. Pairs of trigger chambers are used to define track slopes with respect to the direction towards the interaction point, from which the track's curvature, i.e. momentum is derived for use in the LVL1 trigger decision. The track slopes are also used as search roads for muon localisation in subsequent levels of triggering and in the offline analysis. The search roads for muon tracking are called "Regions of Interest" (RoI). The precise determination of the muon momentum at LVL2 and in the Event Filter (EF)

is entirely based on tracks flagged by the RoIs. At low luminosity where the track pattern in the tubes is little obscured by background hits, the offline analysis may find additional tracks, not flagged by trigger chambers, adding so called "soft RoIs". A detailed description of the ATLAS triggering system is given in [3] and [4].

At LHC the large majority of hits in the MDT detector is not caused by charged tracks but by converted γ 's which are generated by slow neutrons, leaking from calorimeters and shielding material. These "background hits" from converted γ 's are the limiting factor for the rate capability of the MDT. Hit rates and ionization created in the tube gas by the γ -background affect the main performance parameters of the MDT, like tracking efficiency, position resolution and readout bandwidth. The SLHC will deliver much higher luminosity and background rates than the LHC. Hence, for an upgrade of the MDT, solutions have to be found to overcome the limitations of the MDT with respect to the high background rates.

II. SIMULATED γ FLUX IN THE EXPERIMENTAL HALL

The background hit rate in the MDT detectors depends on the γ -flux in the experimental hall. Figure 1 shows the simulated γ -flux as given in [5].

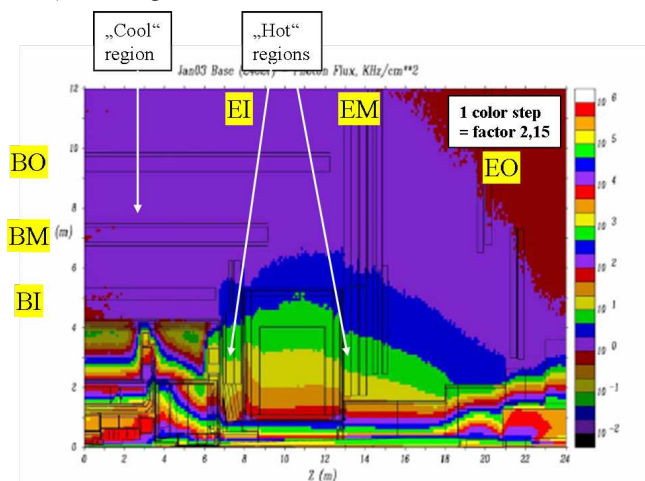

Figure 5.13 Photon flux in a full Atlas quadrant (GCALOR - Jan03).

Figure 1: Gamma flux in the ATLAS experimental hall.

The area colored in blue depicts the region of relatively low γ -flux, where the MDTs of the barrel (BI, BM and BO) and

those of the outer parts of the middle and outer wheels (EM and EO) are located. In contrast, the inner parts of the inner and middle wheels (EI and EM), in the areas coloured in yellow, receive about a factor of ten more γ -flux. Reference [5] explains the high flux in the forward part from the fact that elastically scattered protons from the interaction point hit the beam pipe about 10 m downstream, creating an intense source of secondary particles. Because of the limited space between beam pipe and inner bore of the end-cap toroidal magnet, shielding in this region is not as effective as around the interaction point, where the calorimeters provide tight shielding.

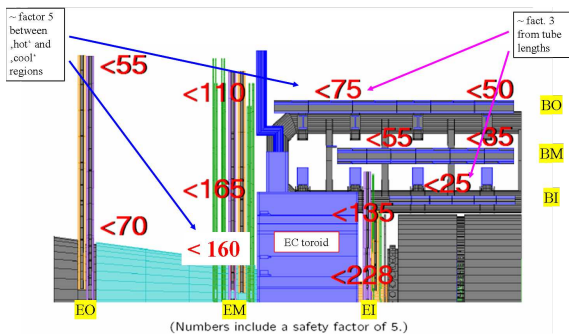

Figure 2: Tube hit rates (kHz) in the MDT detector at $5\times$ the simulated background hit rate. The rate variations among the three barrel layers are mainly due to tube length variations (about 1.7 m to 5 m length from BI to BO).

The uncertainties of the simulated flux are estimated to be composed of a factor of 1.5, due to uncertainties of the cross section at the primary vertex and by a factor of 2.4 for the error on the particle transport across the shielding material. For the hit rates in the MDT chambers there is an additional uncertainty of 1.4 due to the absorption of the γ 's in the material of the tube (aluminum wall and gas). The compounded error on the predicted background hit rates in the MDT tubes results in $1.5\times 2.4\times 1.4 = 5$. Assuming that actual hit rates may exceed the simulated ones by this large factor, all rate estimations in this paper are applying the "safety factor" of 5.

For the extrapolation of hit rates from LHC to SLHC, a factor of 10 is applied, corresponding to the anticipated luminosity increase. A reduction of this factor of 10 may occur if the currently used stainless steel beam pipe was replaced by a beryllium pipe, which might reduce rates in the forward direction by a factor 2–3. If, in contrast, the SLHC upgrade leads to a displacement of the final focus magnets in direction to the interaction point, part of the space presently used for shielding may have to be given up, which may raise the background and partly or fully compensate the improvements due to the beryllium pipe.

The error range on expected rates will be reduced as soon as the LHC will operate under close-to-nominal conditions. For the purpose of the discussion in this article we assume that background rates in the MDT detector will be 5 times and at the SLHC 50 times the ones simulated.

III. EXPECTED TUBE HIT RATES DUE TO γ -FLUX AND CONSEQUENCES FOR THE MDT

The γ -flux in the experimental hall translates into hit rates in the tubes of the MDT system as shown in figure 2. At the inner tip of the EI and EM wheel the rates are 10–15 times higher than in the BI layer of the barrel. The variation is partly due to the γ -flux and partly due to the tube lengths in the different chamber types.

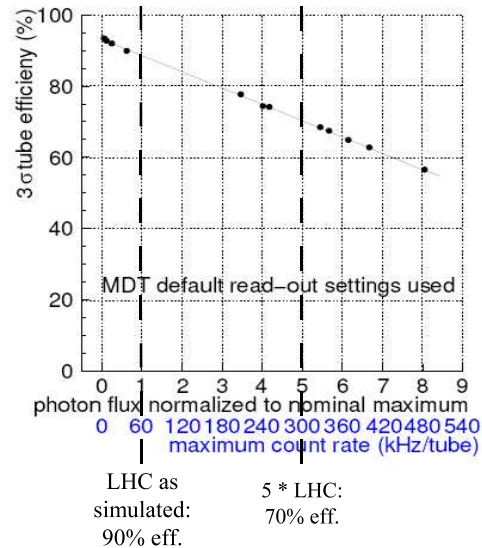

Figure 3: Tube hit efficiency as a function of background hit rate.

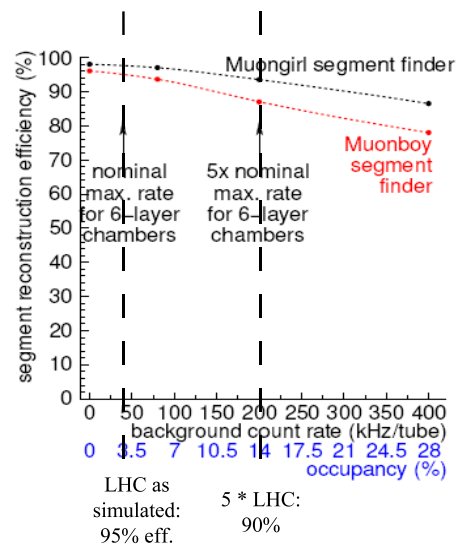

Figure 4: Track reconstruction efficiency as a function of background hit rate.

The background rates from the γ -flux lead to inefficiencies of the tube in recording μ -tracks, as a γ -hit preceding the passage of a track may mask the signal produced by the track. Missing tube hits along the trajectory of the track may reduce the reconstruction probability of this track, leading to a possible misidentification or loss of a physics event. Therefore, if a luminosity increase leads to a reduction of reconstruction efficiency beyond a certain point, the benefit of higher event rates may be

outweighed by a loss in the significance of the physics signal. Thus, a careful analysis of the rate capabilities of the MDT is a mandatory step in the preparation of a luminosity upgrade as planned for the SLHC.

The rate capabilities of the MDT have been tested at the Gamma Irradiation Facility (GIF) at CERN where high momentum muon tracks were crossing a MDT chamber in the presence of an adjustable high intensity γ -source, [6, 7]. The position of the muon tracks was known with an accuracy of about $20 \mu\text{m}$ due to the presence of silicon strip detectors. Figure 3 shows the hit efficiency of a single tube versus background count rate, while figure 4 gives the reconstruction efficiency for the corresponding tracks. At $5 \times$ nominal the track reconstruction efficiency is between 88 and 95%, depending on the reconstruction algorithm.¹

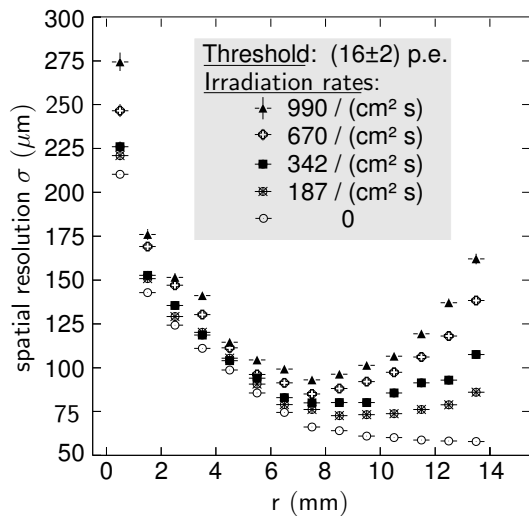

Figure 5: Position resolution as a function of γ -flux.

Figure 5 shows the position resolution of a given tube versus the impact radius of the track at five different levels of γ -flux. The degradation of position resolution with increasing background rates comes from space charge accumulated in the drift volume due to positive ions, an effect which grows with the length of the drift of the primary electrons, as can be seen in the figure. The average position resolution per tube degrades from about $80 \mu\text{m}$ at zero background to about $120 \mu\text{m}$ at $5 \times$ nominal LHC rates. This is considered still acceptable for most of the physics channels under consideration.

Another consequence of the background rates is the data volume to be transferred to the rear end electronics. Figure 6 shows the level of saturation (%) of the optical readout links of a typical large and average chamber vs. the hit rate of the individual tubes. At a hit rate of 125 kHz a data rate of about 300 Mbit/s is transferred to the Readout Driver (ROD) for an average chamber of 288 tubes, corresponding to about 20 % of the available bandwidth of the link (about 1.4 Gbit/s for user data), while at 360 kHz, which corresponds to rates in the end-cap, about 50% of the available bandwidth are used. For a large chamber with 432 tubes, the same background conditions lead to 33% and 66%

saturation, respectively. For comparison: a BI chamber in the barrel with 240 tubes and 25 kHz rate per tube, only uses about 8% of the available bandwidth².

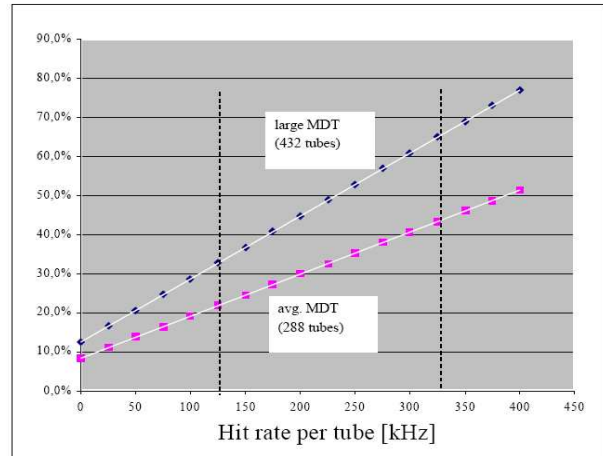

Figure 6: Level of saturation of the optical links for two chamber types versus tube hit rate. The maximum bandwidth on the link, available for user data is 1.4 Gbit/s. The overhead produced by the TDCs (two 32-bit words per trigger) creates an occupancy of the link of 8–12% (depending on the number of tubes), even if no hits are present. All numbers refer to a LVL1 trigger rate of 100 kHz.

These numbers demonstrate that link saturation at LHC is below a value of about $2/3$, even in the hottest regions. For operation at SLHC, however, the presently available bandwidth is largely insufficient.

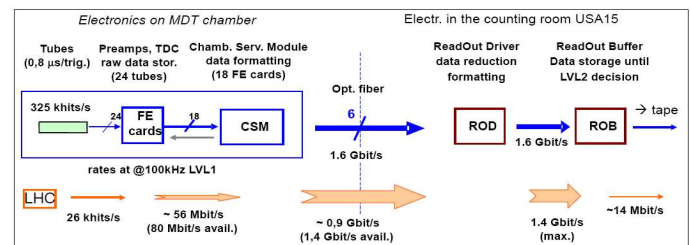

Figure 7: Scheme of the MDT readout.

A diagram of the readout scheme of the MDT is shown in figure 7. The number of 325 kHits per tube is for a chamber in the "hot" region, which leads to an average occupancy per triggered event of about 50%. With 288 tubes (an avg. chamber), 700 Mbit/s are transferred over the optical link to the ROD. The ROD, receiving data from up to six chambers, achieves a significant reduction of the data volume by discarding control data (empty data frames, synchronisation words etc.). The output is sent via a S-link to the ROB, where data are stored for analysis by the LVL2 trigger and the Event Filter (EF) and, eventually, permanent storage. The ROD is thus condensing up to six input data streams from the MDT into one output data stream to the

¹The reconstruction efficiency of an algorithm is, in general, complementary to the fake track rate, so the selection of the optimum algorithm is quite difficult.

²There is an overhead of data frames and control words which leads to a "base" data volume of about 110–160 Mbit/s at 100 kHz LVL1 trigger rate, even if no hits are present in the chamber. Most of this overhead is discarded in the next processing stage, the ROD.

ROB. Even with the data reduction in the MDT, this is only possible because most MDTs at LHC operate at data rates far below saturation. Care is taken to balance the data loads for each ROD by combining high rate with lower rate chambers. Details of this "load balancing" in the ROD are given in [8] and [2].

Consequently, at the much higher rates of the SLHC, the present architecture would not allow the RODs to service up to six CSMs, if backward pressure from the ROBs (i.e. data loss and/or additional dead time) is to be avoided. If only the available bandwidth for data readout was the limiting factor, a single ROD could be used for each CSM, while the bandwidth of the optical links between CSM and ROD and between ROD and ROB would have to be increased. A requirement of, e.g., 2.5 Gbit/s could be put into reality using new optical links like the GBT (see this conference). As for the RODs and ROBs, the processor speed and architecture would have to be reviewed for handling the increased data rates. However, as discussed above, the present MDT chambers would become unacceptably inefficient at such high hit rates and would have to be replaced by chambers of a different type. The present MDT technology could only be maintained in regions where the hit rate does not exceed 400 kHz per tube.

IV. UPGRADE STRATEGIES FOR THE MDT IN A SLHC ENVIRONMENT

As a consequence of the previous section, the present MDT detectors, characterized by their diameter of 30 mm, can only operate up to a tube hit rate of about 400 kHz if an efficiency for track hits of $\geq 70\%$ is to be maintained. In the forward regions of the MDT these limits will most likely be exceeded by factors of 5–10 and alternative concepts for tracking chambers must be found.

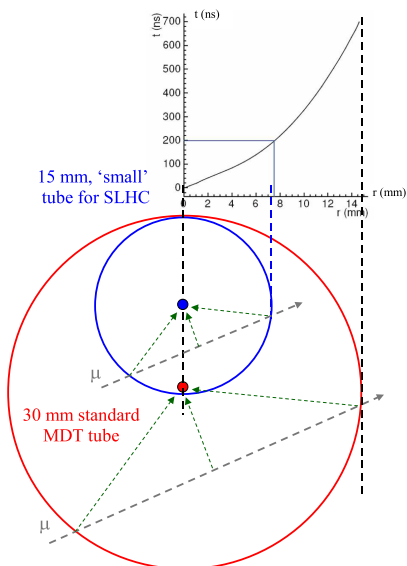

Figure 8: Advantages of small tubes at high rates: due to the non-linear relation between radius and drift time, the maximum drift time is not proportional to the tube radius, but about 1/3.5 in a 15 mm compared to a 30 mm tube. In addition, the shorter segment of a traversing track leads to shorter pulses and reduced dead time.

We present two options for an upgrade with tube-based detectors. Alternative chamber types with pixel-like structure (e.g.

GEMs, Micromegas) may also be considered candidates for an upgrade but are not discussed in this paper.

A rough estimate for the number of chambers to be replaced in the hot regions leads to about 180 chambers in the end-cap region, covering an area of about 700 m². This, obviously, would require a substantial R&D and construction effort by the MDT collaboration.

A. Small tubes

A drastic improvement of the rate capabilities of the MDT tube detectors could be achieved by a reduction of the tube diameter from 30 mm to e.g. 15 mm. This will reduce the drift time, and with it the sensitive time for background hits, by a factor of 3.5 due to the non-linear characteristics of the space-to-drift time relation in the ArCO₂ gas, see figure 8. A further reduction of the background hit probability comes from the shorter track segment crossing the tube, which leads to shorter pulses and hence to a reduced probability for converted γ 's to mask subsequent track hits. Another reduction comes from the two times smaller area exposed to γ 's. Compounding these figures, a total hit rate reduction of 7 is expected, while the probability for an inefficiency due to hit masking is reduced by a factor of about 20 due to the additional effect of shorter signal length.

The small tubes also allow more tube layers to be installed in the available space, leading to improved position resolution and robust tracking in the presence of tube inefficiencies.

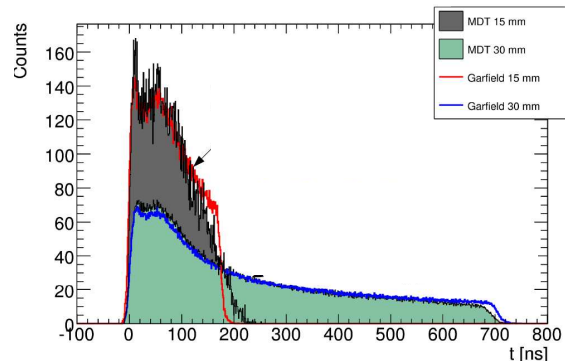

Figure 9: Drift time spectrum of 30 mm and 15 mm tubes as obtained in a test with cosmic tracks.

Figure 9 shows the drift time spectrum from a 15 mm tube in comparison with the one of a 30 mm tube, overlaid with Garfield simulations, which demonstrates the reduction of the maximum drift time by a factor of 3.5. These results were taken with cosmics, where the cosmics were not well hardened, which may explain the discrepancy between simulation and measurement in the case of the small tubes. Details of this test are given in [9].

B. Field shaped tubes

An alternative way to reduce the active volume in drift tubes has been proposed by J. Chapman et al. (University of Michi-

gan). Figure 10 shows a 30 mm tube, where two plates have been added, roughly at half-distance between wire and wall. The potential of the two plates is close to the potential of the wire, deforming the drift field in such a way that only a small region of about 4 mm thickness has field lines ending at the wire. Only primary ionisation originating from this region drifts to the wire and undergoes gas amplification, while ionisation from other regions drifts to the field plates where little or no amplification takes place. This way, only a short fraction of the track contributes to the observed signal, leading to a short pulse and a small probability of masking. The hit rate is also strongly reduced, as the ionisation of many converted γ 's does not reach the central wire.

For optimal position resolution, tracks should cross the drift field at right angle. Therefore, all tubes in a chamber should be turned towards the interaction point ("clocking").

A set of tubes to be tested at the GIF facility is currently in preparation.

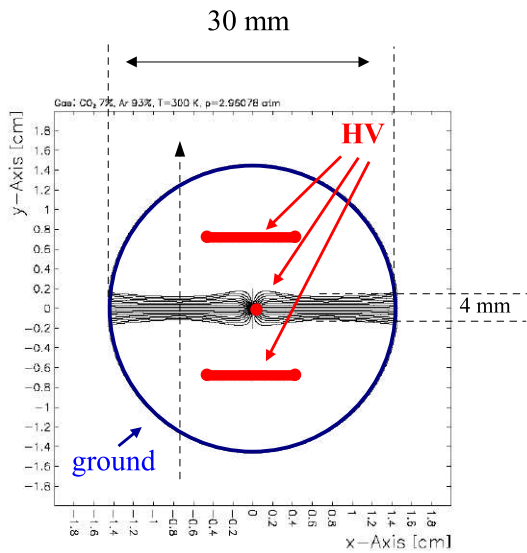

Figure 10: Reduction of the active volume in a tube with field shaping plates. Primary ionisation created outside a 4 mm wide drift layer does not drift to the amplifying central wire but is collected by field plates, where no significant amplification takes place. Field lines not ending on the central wire are not shown.

C. Upgrade of electronics

The large increase of occupancy at the MDTs calls for a corresponding upgrade of the readout bandwidth and storage capacity of the on- and off-chamber storage elements (TDC, CSM, ROD, ROB) as discussed in section III. However, as mentioned in section I., the large majority of the transferred data will not correspond to a RoI, as most of the chambers will not contain a charged track but only background hits. Hence, it would lead to an important reduction of the data volume, if only those chambers were transferred from CSM to ROD which have a RoI attached to it.

In the normal LHC data taking mode the RoI information prepared by the muon trigger chambers is collected by the central trigger processor of the muon system (MuCTPI). The

MuCTPI prepares a "short list" of the RoIs for the LVL1 decision, which mainly contains the number of RoI above certain predefined thresholds like 6 and 20 GeV. On a positive LVL1 decision, the MuCTPI prepares a detailed list of the RoI information for the LVL2 decision. This list allows to identify the chambers containing the track which generated the RoI. The list also contains flags to indicate that a track is close to a chamber edge ("overlap region"). In an average event there are only a few RoIs supplied by the muon trigger, the average being 1.5.

The latency for the delivery of the detailed RoI list is only a few micro-seconds, which is small compared to the average delay between two subsequent LVL1-triggers (10 μ s at 100 kHz trigger rate).

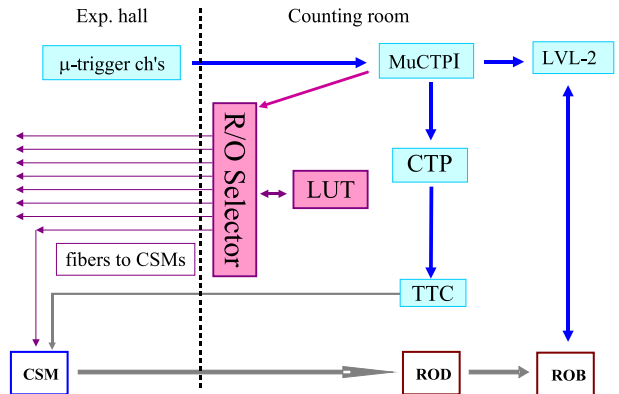

Figure 11: Schematic diagram of the muon trigger system and a possible implementation of selective readout.

Obviously, the information prepared for the LVL2 could also be used to discriminate between those MDTs which correspond to a RoI, i.e. contain a charged track, and the majority of the other MDTs, which only contain background hits. The data of the latter could be deleted already at the level of the CSM and would thus cease to contribute an unnecessary load to the readout system.

Data not marked by a RoI can be safely discarded, because

- the LVL2 and the EF, guided uniquely by the RoI, would not consider them for the trigger decisions.
- at high background the offline tracking algorithms would not be able to identify additional tracks (not labelled by a RoI), because track recognition from tube hit patterns is not possible, the background of fake tracks being far to large.

Figure 11 shows a possible readout scheme for selective readout. The role of the "Readout Selector" is to derive, for each RoI supplied by the MuCTPI, a list of chambers which may contain segments of the corresponding track. If a RoI was flagged, e.g. by a track segment in the middle layer of the barrel, all three barrel chambers along the track (i.e. a full barrel "tower") would have to be read out, see figure 12. Based on this list, the Readout Selector sends a YES or NO to the corresponding CSMs.

As most chambers do not have a track (hence no RoI), this readout scheme would lead to a reduction of the transferred data volume by a large factor, reducing the required bandwidth on

the optical links and the storage capacities of the ROD and ROB processors. Based on the muon rates predicted for LHC and SLHC, a reduction factor of 10–50 can be expected. Even if only a factor of 10, the bandwidth of the present LHC links would be sufficient for SLHC.

The data transfer between TDCs and CSM would, of course, not profit from this data reduction scheme. All hits recorded by the TDC would have to be transferred to the CSM, which would mean an increase in storage capacity in the TDC and of the transfer rate to the CSM, cf. figure 7.

Due to the tenfold higher level of ionizing radiation at SLHC a total ionizing dose (TID) of up to 500 krad would have to be expected in ten years of operation. For newly designed ASICs this should not be a problem, as technologies with much higher tolerance are available.

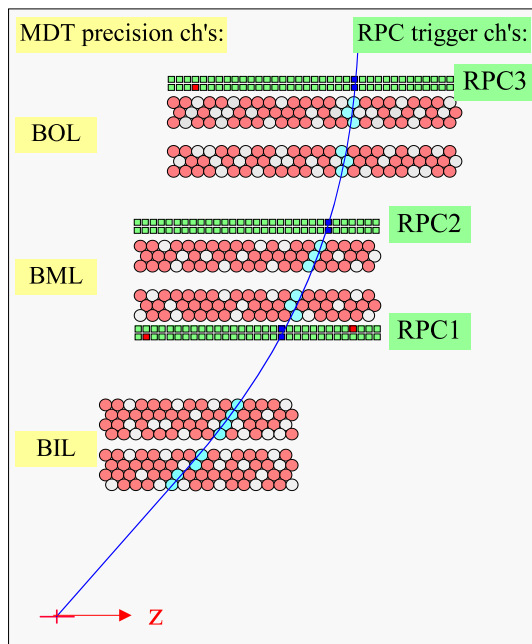

Figure 12: Cross section through a "tower" of three barrel chambers, showing MDT as well as RPC trigger chambers. RoIs are generated by coincidences between hits in RPC layers which allows to find tracks in the MDT, even at high occupancy. Track segments found in the outer and middle MDT are extrapolated to the inner layer which is not equipped with RPCs. In selective readout mode a whole tower of MDTs would be read out if there is any RoI in it. If the track is flagged to be in the overlap region, i.e. the track is close to a tower boundary and might, due to its curvature, migrate to the adjacent tower, the adjacent tower is also read out.

As for the FPGAs in the CSM processors, the currently used XILINX Virtex-II devices started to fail in tests at about 50 krad TID and would, therefore, not be suitable for SLHC applications in the experimental hall. The radiation performance of more recent FPGA families seems not yet to be demonstrated. Therefore, it seems uncertain whether Field Programmability at the frontend can be maintained for the SLHC.

V. SUMMARY

The muon detector in its present form would be able to support a moderate luminosity upgrade by about a factor of 2, if background rates in the hall were reduced e.g. by the installation of a Beryllium beam pipe, and if the present shielding structure was maintained (i.e. no loss of shielding due to modified beam optics). To make the MDT system usable for 10 times higher rates, as foreseen for the SLHC, a number of chambers in the forward direction of the end-cap would have to be replaced by chambers with reduced acceptance for γ -conversions, using new drift tube technologies.

For the chambers in the barrel and in the outer end-cap region, a replacement of the on-chamber electronics may be sufficient to improve readout bandwidth and radiation tolerance. Optical readout links and off-chamber processors could be maintained if a new readout concept was implemented which only transfers relevant tracking data, using the guidance of the RoIs, as provided by the trigger chambers.

A number of R&D projects are prepared to address the relevant questions.

REFERENCES

- [1] The ATLAS collaboration, *The ATLAS Experiment at the CERN Large Hadron Collider*, JINST **3** S08003 (2008)
- [2] Y. Arai et al., *ATLAS Muon Drift Tube Electronics*, JINST **3** P09001 (2008)
- [3] The ATLAS Collaboration, *First-Level Trigger Technical Design Report*, CERN/LHCC/98-14, (1998)
- [4] The ATLAS Collaboration, *ATLAS High-Level Triggers, DAQ and DCS*, CERN/LHCC/2000-17, (2000)
- [5] M. Bosman et al., *Estimation of Radiation Background, Impact on Detectors, Activation and Shielding Optimization in ATLAS*, ATLAS Note ATL-GEN-2005-001 (2005).
- [6] W. Riegler et al., *Front-end electronics for drift tubes in a high-rate environment*, Nucl. Instrum. Meth. **A446** (2000) 555.
- [7] M. Deile et al., *Resolution and efficiency of the ATLAS muon drift-tube chambers at high background rates*, Nucl. Instrum. Meth. **A535** (2004) 212.
- [8] T. A. M. Wijnen, *The MROD data format and tower partitioning of the MDT chambers*, ATLAS Note ATL-DAQ-2003-023; ATL-COM-MUON-2003-011 (2007), <http://doc.cern.ch/archive/electronic/cern/others/atlnot/Note/daq/daq-2003-023.pdf>
- [9] J. Dubbert et al., *Development of precision drift tube detectors for very high background rates at the super-LHC*, Nucl. Sci. Symposium Conf. Rec., NSS '07, IEEE vol. 3, (Oct. 26, 2007 – Nov. 3, 2007), 1822.