

THE RF POWER SYSTEM WITH BEAM LOADING CANCELLATION FOR THE KEK-PS BOOSTER

S. Ninomiya, S. Takano, M. Yoshii, M. Toda, J. Kishiro,
S. Hiramatsu, and T. Katori*

National Laboratory for High Energy Physics, 1-1 Oho,
Tsukuba-city, Ibaraki, 305 Japan

*Denki Kogyo Co. Ltd. 4052-1 Sakuradai, Nakatsu, Aikawa-cho,
Aikoo-gun, Kanagawa, 243-03 Japan

Abstract An rf system which is free from beam loading has been constructed. The gains of the feedback loops in the system keep their designed values. A grid power supply was also designed to control the offset current of the vacuum tube.

INTRODUCTION

A new rf system for the KEK-PS booster has been constructed in 1988. The system is designed to accelerate a beam intensity up to 3A circulating beam current without the influence of beam loading.

The system consists of a cavity, a power amplifier and its power supplies, and a ferrite bias system. A schematic diagram of the system is shown in Fig. 1, Table 1 shows the main parameters of the system.

The beam duct in the rf system has two gaps. One is the gap in the cavity for acceleration, while the other, located upstream of the acceleration gap, picks up the wall current of the beam. The current is directly fed into the cathode of the vacuum tube installed near the cavity. This current drives the cavity with the opposite polarity to the loading current and reduces the loading effect on the rf system.

THE CAVITY

Twenty-four Ni-Zn ferrite disks with the parameters listed in Table

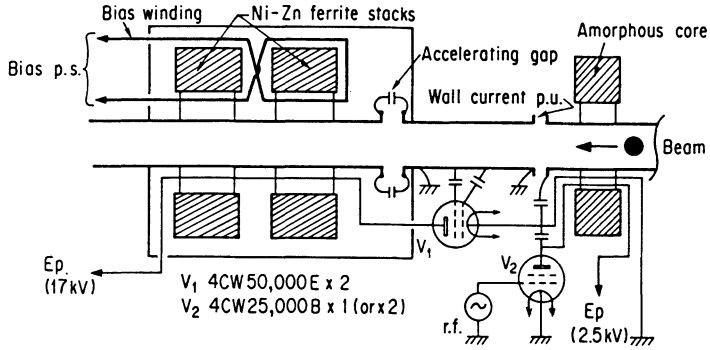

FIGURE 1. The rf system. The cavity and the amorphous core are shown as the cross section.

1 are installed in the cavity. In order to make the bias windings, by which bias field on the ferrite is produced, the ferrite disks are grouped into two stacks, four figure-eight windings are constructed around the ferrite stacks. The ferrite disks are sandwiched by the copper disks having a spiral path of cooling water.

The outer conductor of the cavity is made of aluminum. Its outer diameter is 810mm, the weight of the cavity is 1300kg.

Two vacuum capacitors (the total capacity is 200pF) are added to the accelerating gap in the cavity to decrease the resonating frequency to less than 2MHz. The inductance of the cavity is $17\mu\text{H}$, the capacitance is 450pF, and the shunt impedance at 1.8MHz is 4.5k Ω (at zero bias current). These values were obtained by using a network analyzer. The parameters in actual operating conditions will soon be measured.

THE WALL CURRENT PICKUP

The gap for the wall current pickup is loaded with an amorphous core whose relative permeability is 10,000. Because of its large imaginary part, the core behaves as a resistor for frequencies higher than several 100kHz. In our case, a resistance of 100 Ω is obtained. Therefore the pickup seen by the wall current is represented by the parallel circuit of a large inductance, a resistance of 100 Ω , a capacitance of 500 pF, and the input impedance of the cathode of the vacuum tube. The capacitance is the sum of the capacitance of the gap, the stray capacitance, and the input capacitance of the vacuum tube. The input impedance of the tube is estimated to be $\sim 8\Omega$, therefore, even at 6MHz, nearly 90%

of the wall current flows into the cathode.

The DC component of the flux in the core from the tube current is cancelled by the other windings on the core, whereas the flux from the wall current is cancelled by a feedback system which is under construction.

THE RF AMPLIFIER

The final stage of the amplifier is a grounded grid circuit. Two tetrodes, 4CW50,000E(Eimac), are connected in parallel, since the transconductance of the two tubes is larger than that of a vacuum tube with greater power. In addition, in the case of parallel tubes, we can get a larger anode current. The larger conductance decreases the input impedance of the tubes, the larger anode current increases the acceptable peak current of the beam.

The anode current of the final tubes consists of two components, one is the drive rf current, which produces the accelerating voltage, and the other is the wall current of the beam by which the loading current in the cavity is cancelled. The phase lag of the wall current component from the anode voltage is 90° -(the synchronous phase). Therefore the power dissipated at the anodes of the final vacuum tubes is large, it is estimated to be 60 kW in average.

The cathodes of the final tubes are also connected to the anode of 4CW25,000B biased at class B. The rf voltage in the cavity is produced by the current of this vacuum tube. Since the input impedance of the cathodes of the final tubes is small, the voltage amplitude at drive tube anode is small. Therefore the power dissipated at the anode is small. The vacuum tube, 4CW25,000B, was selected for its large anode current. The control grid of 4CW25,000B is driven by a push-pull amplifier. The tetrode, TH593(Thomson), is used for this amplifier. The drive power of the system is estimated to be 100W at peak rf voltage.

THE FERRITE BIAS SYSTEM

The resonating frequency of the cavity is varied by the ferrite bias field produced by the current in the windings on the ferrite. The figure-eight windings are connected to form a two-turn coil for each ferrite stack. The bypass capacitors are connected between the windings

and ground. The bias windings seen by the bias power supply(p.s.) is 77 μ H with parallel capacitance of 0.45 μ F. The resonating frequency of the winding is, therefore, 26kHz at zero bias current.

The current of the bias p.s. changes from 100A(at 2MHz) to 1000A(at 6MHz). The output voltage of the p.s. is 15V, and its output current is designed to be 1000A in average. The bandwidth of the ferrite bias p.s. is from DC to 8kHz.

POWER SUPPLY FOR THE FINAL ANODES

In order to measure the behaviour of the ferrite at higher flux density, the output power of the p.s. was made to be 200 kVA in average. The output voltage ranges from 10kV to 20kV.

THE GRID POWER SUPPLIES

We designed the screen grid p.s. Its circuit diagram is shown in Fig. 2. Where FET 1 and 2 represent several FETs connected in series. The resistor, R_1 , determines the maximum source current from the p.s., while the sink current is determined by R_2 . The maximum sink current is designed to be 600mA, and source current is 300mA.

This p.s. eliminates the large resistor of several 100W usually connected between the screen grid to ground. The current from the grid flows to ground via. this resistor.

In order to reduce the power dissipation at the anodes of the final vacuum tubes, we employed the floating bias method for this stage. The control grid voltage of the tube is switched from -600V to -300V at beam injection. The p.s. must be designed to have the fast response which is determined by the growth of the rf component of the injected beam current.

The circuit of the bias p.s. for the control grids is also similar to that shown in Fig. 2, but it is modified into a negative output circuit. The FETs are p-ch.MOS FETs. The output voltage of the p.s. is controlled by an external voltage. The response from -600V to -300V at

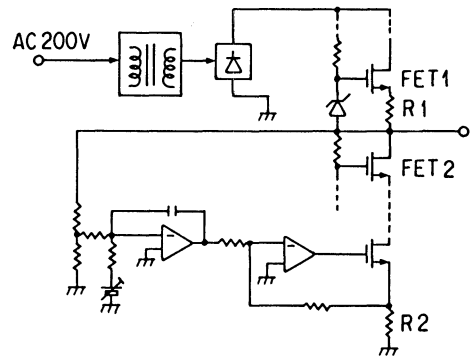

FIGURE 2.

the output is less than a period of $50\mu\text{sec}$.

THE DRIVE CIRCUIT OF CONTROL GRID

An all-pass filter is used for the drive circuit of the control grid of pre-drive and drive stages to reduce the power dissipation at the circuit¹. The circuit diagram is shown in Fig. 3, where C_1 represents the input capacitance of the control grid.

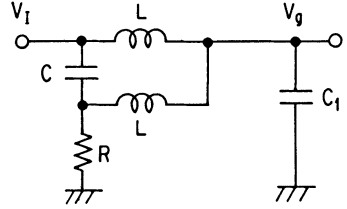

FIGURE 3.

The network acts as a low pass filter with a damping factor of 0.5. The input impedance of the network is R for all frequencies. The values of L , C , and R are determined by the value of C_1 and the cut-off frequency required. The network reduces the drive power to $1/2$ in comparison with the case where a simple swapping resistor is used.

CONCLUSION

The loading effect increases the resonating frequency of the cavity to a frequency higher than the accelerating frequency (before transition). Hence the cavity transfer function for the modulation signal reduces its value at low modulation frequencies² (see also the NOTE). As a result, the loading effect reduces the loop gains of feedback loops in the rf system. This system does not change the resonating frequency of the cavity, therefore the gains of the feedback loops keep their designed values. The acceptable beam intensity of this system is determined by the maximum current and power at the anodes of the final stage.

The tuning of the system will continue until Sep. 1990. The behaviour of the ferrite at the rf flux density of 0.02 Tesla will also be measured.

ACKNOWLEDGEMENTS

The authors would like to thank Professor Kihara who gave us the opportunity for making this system. We would also like to thank Professor T. Nishikawa for his encouragement for this work.

REFERENCES

1. S. W. Mosko, et al., IEEE Trans. Nucl. Sci. NS-24, 1977, p.1786
2. F. Pedersen, IEEE Trans. Nucl. Sci. NS-22, 1975, p.1906
3. K. W. Robinson, CEA Report No. CEAR-1010, 1964
4. F. Pedersen, IEEE Trans. Nucl. Sci. NS-32, 1985, p.2138
5. D. Boussard, IEEE Trans. Nucl. Sci. NS-32, 1985, p.1852
6. R. Garoby, IEEE Trans. Nucl. Sci. NS-32, 1985, p.2332

NOTE Consider the transfer function, G_{pp}^g , in Ref. 2. Take the limit, $s/\sigma \rightarrow 0$. We get, with $\phi_L = 0$,

$$G_{pp}^g = 1 + Y(\sin \phi_B - Y \cos^2 \phi_B) / (1 + Y^2 \cos^2 \phi_B)$$

The transfer function, G_{pp}^g , becomes small for large Y .

TABLE 1. The main parameters of the rf system.

Length of system	1.72 m,	Diameter of the cavity	810 mm
Length of the cavity	1.2 m,		
Dimensions and the number of the Ni-Zn ferrite;			
	620mm(outer diam.),	350mm(inner diam.),	25.4mm(thick) x24
Permeability	~250(TDK SY-3)		
Shunt impedance	4.5 k Ω (at zero bias, low rf level)		
Inductance	17 μ H(at zera bias)		
Capacitance	450 pF.		
Frequency range	1.8 ~ 7 MHz		
Bias current	100A ~ 1000A(design value)		
Dimensions and the number of amorphous cores			
	300 mm(outer diam.),	215 mm(inner diam.),	22 mm(thick) x4
Permeability	10,000		
Impedance (>500kHz)	>70 Ω		
Final tube	4CW50,000E(Eimac) x2		
Driver tube	4CW25,000B(Eimac) x1 (or x2)		
Pre-driver	TH593(Thomson) x2		
Final anode voltage	17.5 kV(100kW) or 13 kV(200kW)		
Anode volt. of driver	2.5 kV.		
Anode volt. of pre-driver	2.5 kV		
Accelerating frequency	2.2 ~ 6.02 MHz.		
Accelerating voltage	15 kV		
Drive power	100 W (at 15 kV)		
Average anode power	60 kW		
Peak current of tubes	60 A		
Beam current	3 A		
Cancellation of loading curr.	~90 %(at 6 MHz)		