



LINEAR ACCELERATOR DESIGNS FOR THE UPGRADE OF THE CERN PROTON INJECTOR COMPLEX (LINAC4, SPL)

M. Vretenar, G. Bellodi, R. Garoby, F. Gerigk, K. Hanke, A. M. Lombardi, S. Maury,
M. Pasini, C. Rossi, E.Z. Sargsyan

CERN, Geneva, Switzerland

Abstract

Looking beyond the commissioning of the LHC, which is expected to start at the end of 2007, CERN is setting up its scientific plan for the years to come. The concerns about the reliability of the old LHC injectors and the need to progressively remove the technical bottlenecks towards higher luminosity in the LHC have initiated a reflection on the design of the main elements of the LHC injection chain.

A plan under consideration foresees in the years 2007- 2010 the construction of a 160 MeV H⁻ linear accelerator, Linac4, injecting into the old 1.4 GeV PS Booster (PSB). In a second stage, the PSB could be replaced by a superconducting linac, the SPL, at an energy between 3.5 and 5 GeV. The Proton Synchrotron (PS) would be in turn replaced by a new PS2 reaching a higher energy of 50 GeV. Linac4 and SPL can operate at a higher duty cycle than needed for LHC injection, allowing functioning as a high-intensity facility for neutrino or radioactive ion physics at a later stage.

This paper describes the design of the two linear accelerators involved in this upgrade strategy, Linac4 and SPL, and outlines some results of the R&D programme aimed at preparing the construction of Linac4.

Contribution to the APAC'07, Indore (India), 26 January-02 February 2007

Work supported by European Community-Research Infrastructure Activity under the FP6 "Structuring the European Research Area" programme (CARE, contract number RII3-CT-2003-506395)

LINEAR ACCELERATOR DESIGNS FOR THE UPGRADE OF THE CERN PROTON INJECTOR COMPLEX (LINAC4, SPL)

M. Vretenar, G. Bellodi, R. Garoby, F. Gerigk, K. Hanke, A. M. Lombardi, S. Maury, M. Pasini, C. Rossi, E.Z. Sargsyan, CERN, Geneva, Switzerland

Abstract

Looking beyond the commissioning of the LHC, which is expected to start at the end of 2007, CERN is setting up its scientific plan for the years to come. The concerns about the reliability of the old LHC injectors and the need to progressively remove the technical bottlenecks towards higher luminosity in the LHC have initiated a reflection on the design of the main elements of the LHC injection chain.

A plan under consideration foresees in the years 2007-2010 the construction of a 160 MeV H^- linear accelerator, Linac4, injecting into the old 1.4 GeV PS Booster (PSB). In a second stage, the PSB could be replaced by a superconducting linac, the SPL, at an energy between 3.5 and 5 GeV. The Proton Synchrotron (PS) would be in turn replaced by a new PS2 reaching a higher energy of 50 GeV. Linac4 and SPL can operate at a higher duty cycle than needed for LHC injection, allowing functioning as a high-intensity facility for neutrino or radioactive ion physics at a later stage.

This paper describes the design of the two linear accelerators involved in this upgrade strategy, Linac4 and SPL, and outlines some results of the R&D programme aimed at preparing the construction of Linac4.

INTRODUCTION

The present LHC injection chain (Fig. 1) consists of a 50 MeV proton linear accelerator (Linac2), followed by the 1.4 GeV PS Booster (PSB), the 26 GeV Proton Synchrotron (PS), and finally by the 450 GeV Super Proton Synchrotron (SPS), which injects into the LHC. While Linac2, PSB and SPS have been commissioned between 1972 and 1978, the first PS beam dates back to 1959.

The injection chain has been upgraded and partly modified in the years 1995-2000 [1] in preparation for the LHC. Beam tests following this upgrade have demonstrated that the nominal LHC beam can be provided at injection in the LHC. However, it is now clear that attaining and possibly exceeding the LHC ultimate luminosity of $2.3 \times 10^{34} \text{ cm}^{-2}\text{s}^{-1}$ will require higher beam brightness (intensity/emittance) from the injector chain, which can only be obtained after a major upgrade of the injectors. Moreover, all of the scenarios that are currently being detailed for possible LHC upgrades [2] rest on the renovation of the present injection chain.

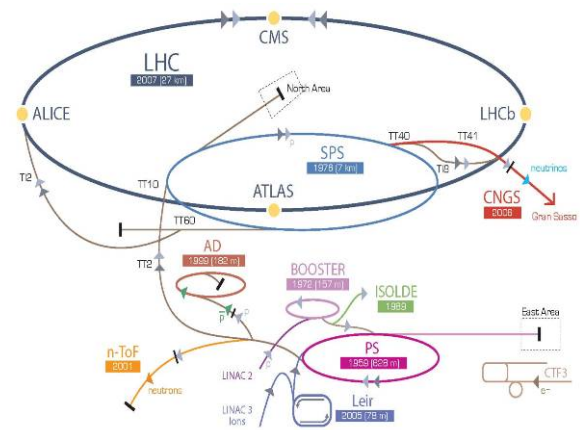

Figure 1: Scheme of the CERN Accelerator Complex

Another motivation for the reconstruction of the injectors concerns operational reliability of the present machines. The correct functioning of all the elements in the injection chain is essential for achieving the required LHC integrated luminosity. However, the past few years have shown recurrent reliability problems: radiation damage on the PS magnets, water leaks in the SPS magnets, failures of the PS main power supply, vacuum problems in the Linac2 tanks. An urgent consolidation programme has been launched, aimed at solving the most immediate problems to ensure a correct start-up and operation of LHC during its first years, but it is clear that some of the foreseen repairs are only temporary fixes and that more problems can be expected in the future.

A third argument for reconsidering the CERN injectors concerns possible future requirements for higher beam intensity from the CERN machines. For some of the presently planned experiments requiring intense secondary beams, ISOLDE for radioactive ion beam (RIB) physics and CNGS for neutrino physics, proton flux from the CERN machines is already at its limits, while both the neutrino and radioactive ion communities have presented ambitious long-term plans [3,4], which if approved would require significantly higher intensities from the CERN machines. Considering the relatively low beam energies required by these applications (~ 1 GeV for RIB, 5 to 10 GeV for neutrino production from pion decay), it appears attractive a scheme where the low energy accelerators in the new LHC injection chain are capable of a higher average beam current than what needed for the LHC, compatibly with the requirements of other physics experiments.

UPGRADE SCENARIO FOR THE LHC INJECTORS

A working group on “Proton Accelerators for the Future” (PAF) has been set up in May 2005 by the CERN management to elaborate a baseline scenario of the possible development and upgrade of the present Proton Accelerator Complex, working in close connection with the working group on “Physics Opportunities with Future Proton Accelerators” (POFPA) that has expressed recommendations on the physics programme.

Focused on the goal of maximizing the integrated luminosity for LHC experiments, a scenario of evolution has been proposed [5], subject to further refinement using the future experience of commissioning and running-in of the collider and its injector complex. The potential of this accelerator complex for producing high-intensity beams has been consequently analysed [6]. A renovated LHC injection chain would be composed of:

- o Linac4, a 160 MeV H^- linear accelerator.
- o An intermediate energy accelerator as the SPL, a 4 to 5 GeV superconducting H^- linac, or alternatively, a 5 GeV Rapid Cycling Synchrotron (RCS).
- o A new Proton Synchrotron (PS2) up to an energy of 40 to 50 GeV.
- o A renovated SPS (or in alternative a new superconducting SPS, SPS+, going to 1 TeV)

A scheme of the present and proposed future layout of the accelerator chain is presented in Fig. 2.

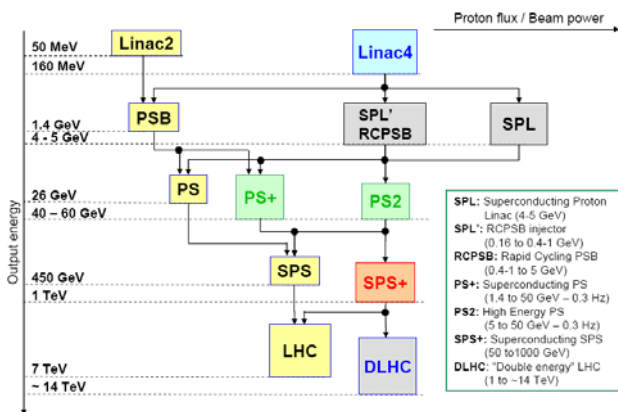

Figure 2: Present and proposed future CERN accelerators

In the medium term, the new 160 MeV Linac4 should be built to overcome the space-charge bottleneck towards higher brightness at injection into the PSB [7]. This will allow the regular delivery of the ultimate beam to the LHC, reduce its filling time and improve the overall reliability of the injector complex. In order to benefit from these improvements already in 2011, Linac4 construction has to start in 2007-2008.

In the long term, the replacement of the PS is crucial for the reliability of the overall accelerator complex, and the replacement of the PSB has to be planned at the same time, to get the maximum benefit from the new PS. Although necessary to reach the expected luminosity from

the LHC, the new intermediate energy accelerator will most probably be dimensioned in relation to the future needs of physics apart from LHC. A Superconducting Proton Linac (SPL) [8] is today the most promising accelerator for high-intensity applications in the CERN context, and if limited to low duty cycle operation can still be competitive in cost with a RCS. A decision in that respect will have to wait until the design is further refined and the future of high-intensity facilities at CERN is clarified.

The first stage of this scenario, which is consistent with the priorities set in 2006 by the CERN Council Strategy Group [9], was included in a proposal from the CERN Director to the Council for an update of the CERN medium-term plan. Together with measures for LHC consolidation and improvements and with urgent consolidation of the injectors, this programme envisages the construction of Linac4 and the detailed design of SPL and PS2 in 2008-2010. A decision on this additional programme is expected during 2007.

A preliminary study of the layout of the new injector complex on the Meyrin site is presently under way. This layout considers the staged construction of the different elements in what will be the future complex, by providing a coherent scheme for their final integration. A first option, presently under study, is shown in Fig. 3. In this layout, Linac4 is below ground level and connected to the PSB by a short transfer line. An underground tunnel housing the SPL can be subsequently built in the continuation of Linac4, with a parallel tunnel housing the SPL klystrons and equipment. Tangential to the SPL line will be the PS2, which will directly connect to the SPS.

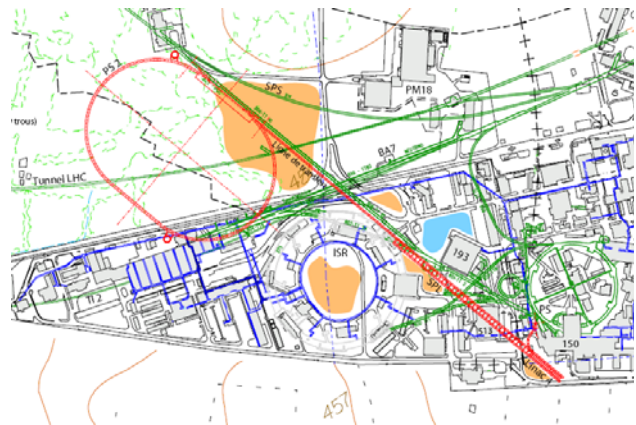

Figure 3: Possible layout of Linac4-SPL-PS2 on the CERN site

LINAC4 IN THE PRESENT ACCELERATOR COMPLEX

Different schemes for increasing beam brightness out of the PS have been considered and several limitations to higher beam brightness have been identified [10]. The first bottleneck towards higher brightness is the space-charge dominated injection into the PS Booster.

Removing this restriction with the construction of a new higher energy linac replacing the 50 MeV Linac2 appears a solution offering many advantages in terms of reliability and flexibility already in the short term. The basic requirement for the new linac injector is to allow making the nominal LHC beam in a single PSB batch instead of the present double batch, which requires doubling the bunch population in the PSB within constant normalised transverse emittances. The incoherent transverse detuning at PSB injection being inversely proportional to the relativistic factor $\beta\gamma^2$, keeping the present tune shift while doubling the brightness is possible by increasing by a factor of 2 the value of $\beta\gamma^2$ at injection; this corresponds to an increase of the injection energy to 160 MeV. Going back to double batch injection should allow reaching and possibly exceeding the ultimate LHC luminosity. The flexibility allowed by using charge-exchange H^- injection for painting in the PSB acceptance should allow preserving the higher brightness during the acceleration process.

Apart from the benefits for the LHC beams Linac4 will also allow to increase the proton flux to the CNGS and ISOLDE experiments by a factor of 2. Furthermore, one can expect a reduction of beam loss in the high-energy accelerators by providing a beam with smaller transverse emittance.

LINAC4 DESIGN

The main Linac4 parameters are based on the requirements for PSB injection. Emittances are defined by the stringent needs of LHC while the maximum number of ions per pulse has been fixed at 1×10^{14} particles per pulse, in order to satisfy future needs of the ISOLDE experiment. The maximum repetition frequency for Linac4 is given by the limiting PSB frequency of 2 Hz.

Considering the present limits of ion source technology and the overall RF requirements, the average pulse current has been fixed to 40 mA. The required number of particles can then be provided with a 400 μ s pulse length. The beam duty cycle for PSB injection is only 0.08%.

A chopping section allows low energy removal of a fraction of the linac bunches, thus avoiding beam loss during longitudinal capture in the PSB. With the selected parameters, the pulse current before chopping has to be as high as 64 mA. Taking reasonable margins for beam loss in the low-energy transfer line between ion source and RFQ and in the chopping line, the RFQ output current is nominally set at 70 mA and the source current, at 80 mA. The target value for the transverse emittance out of the source has been set to 0.2 π mm mrad, a value compatible with present source technology that will allow for about a factor 2 reduction in the emittance at PSB entrance with respect to the present Linac2. The overall Linac4 beam parameters are summarised in Table 1.

The operating frequency of Linac4 is dictated by the availability at CERN of 352.2 MHz klystrons, circulators and waveguides from the LEP RF system and by the use of the RFQ from the IPHI project from CEA and IN2P3

[11], which is intended to be sent to CERN for use in Linac4 after the beam tests at Saclay. It is foreseen to double the RF frequency to 704.4 MHz in the last section of Linac4, thus increasing efficiency and gradient.

Table 1: Linac4 Beam Parameters

Ion species	H^-	
Output Energy	160	MeV
Bunch Frequency	352.2	MHz
Max. Rep. Rate	2	Hz
Beam Pulse Length	400	μ s
Max. Beam Duty Cycle	0.08	%
Chopper Beam-on Factor	62	%
Chopping scheme:	222 transmitted / 133 empty buckets	
Source current	80	mA
RFQ output current	70	mA
Linac current	40	mA
N. particles per pulse	1.0	$\times 10^{14}$
Source transverse emittance	0.2	π mm mrad
Linac transverse emittance	0.4	π mm mrad

The overall architecture of Linac4 is shown in Fig. 4. The chosen sequence of accelerating sections is standard for modern pulsed linac designs. The ion source is followed by a Radio Frequency Quadrupole (RFQ), a chopping line and the accelerating structures. Three types of structures bring the energy up to 160 MeV: Drift Tube Linac (DTL) up to 40 MeV, Cell-Coupled Drift Tube Linac (CCDTL) up to 90 MeV and finally a Side Coupled Linac (SCL) to the final energy. A transfer line equipped with debunching and collimation sections connects Linac4 to the existing Linac2 transfer line.

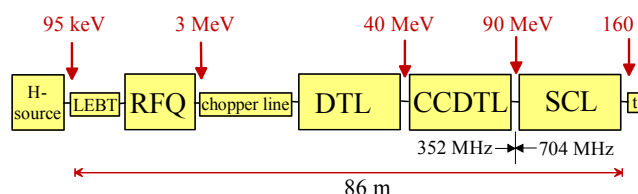

Figure 4: Scheme of Linac4

Although the RF duty cycle of Linac4 will be only 0.1%, all the accelerating structures have been designed for a maximum duty cycle of 10%, to enable future operation of Linac4 as first part of the high-energy high-intensity SPL. As a way to minimise initial installation costs, all the hardware (accelerating structures, magnets, diagnostics, RF high-power components, etc.) of the linac will be built for future high-duty operation, whereas the electronics (power supplies, etc.) and the infrastructure will be dimensioned only for the low duty cycle required for the PSB.

The chopper line for Linac4 is being built at CERN, to be tested in a dedicated test stand presently in preparation. It includes two meander line fast chopping devices printed on an alumina substrate and water cooled, housed inside large aperture quadrupoles. The choppers have been assembled and successfully tested for RF, vacuum and thermal properties [12]. The fast rise and fall times

(2 ns) are provided by a solid-state driver presently under testing. Figure 5 shows the layout of the 3 MeV test stand, where first beam tests are expected for the end of 2008.

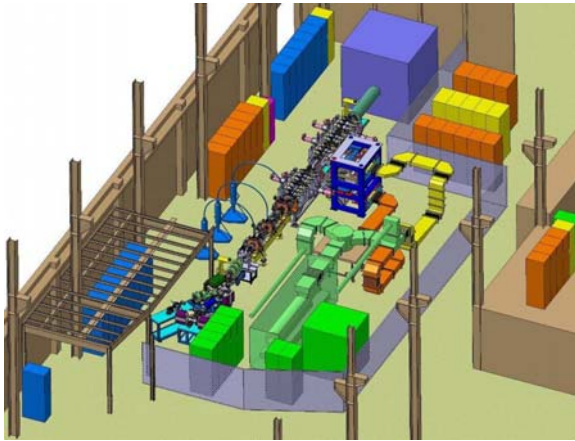

Figure 5: The 3 MeV test stand in preparation at CERN

The Linac4 accelerating structures are based on a conservative design, required for reliability and for the future high-intensity operation of the SPL. Modern concepts for intertank coupling are used wherever possible. Accelerating gradients are relatively high, between 3 and 4 MV/m, allowing for a compact structure with peak surface fields still below 1.7 Kilpatrick. Large apertures (20 to 32 mm diameter) provide enough safety margins with respect to beam size when operating at high intensity.

The DTL is a standard Alvarez-type structure equipped with Permanent Magnet Quadrupoles (PM), while the CCDTL is a structure with external electromagnetic (EM) quadrupoles placed between short tanks. Sections of three tanks are coupled by coupling cells, thus forming a single resonator [13]. This design allows using EM quadrupoles above 40 MeV, with sufficiently high shunt impedance and simplified RF distribution. The construction cost is lower than for a DTL, whose cost is dominated by the tight tolerances required for positioning of the quadrupoles inside the drift tubes. A 3D schematic drawing of Linac4 is presented in Fig. 6.

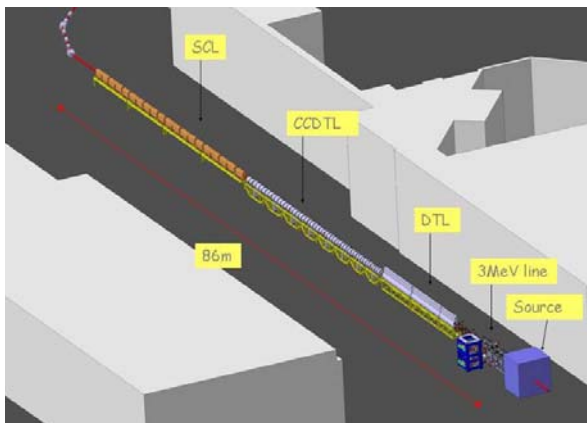

Figure 6: 3D view of Linac4

The basic parameters of the Linac4 accelerating structures are reported in Table 2. Prototypes for the Linac4 accelerating structures are under construction at CERN (CCDTL) and in Russia (DTL, CCDTL, SCL). The R&D for Linac4 is part of a Joint Research Activity partially funded by EU.

Table 2: Parameters of Linac4 accelerating structures

	RFQ	Chopper line	DTL	CCDTL	SCL	
Energy	3.0	3.0	40	90	160	MeV
Frequency	352	352	352	352	704	MHz
Current	70	40	40	40	40	mA
RF Power	1.0	-	3.9	6.4	12.5	MW
Klystrons	1	-	5	8	4	-
No. tanks	1	-	3	24	20	-
Length	5.95	3.7	13.4	25.2	28.0	m

SPL DESIGN

The design of the Superconducting Proton Linac (SPL) started originally in 1996, with the idea to reuse the RF equipment (klystrons and superconducting cavities) from the decommissioned LEP collider. A first Conceptual Design Report (CDR) [14] was published in 2000, aimed at the specific needs of a Neutrino Factory based at CERN.

Since the first CDR, new techniques have been proposed for the production of intense neutrino beams (neutrino superbeam and beta-beams [15]), leading to a revision of the basic machine parameters. At the same time, the progress in superconducting cavity preparation techniques suggested to change the design from LEP-type 352 MHz sputtered Niobium cavities to 704 MHz bulk-Niobium cavities that allow a higher gradient. Moreover, more experience is presently available in the design and construction of long (10-15 m) cryomodules containing cavities as well as quadrupoles and diagnostics at cryogenic temperature, suggesting moving from a classic design with short cryostats spaced by warm quadrupoles to a new and more compact design with less cold to warm transitions. The new design is summarised in a second CDR published in 2006 [8]. Again, Linac4 makes the initial section of the SPL, followed by an additional normal-conducting module bringing the beam energy to 180 MeV, and then by two superconducting sections made of 5-cell 704 MHz cavities, designed for a nominal β of 0.65 and 1, respectively. The RF power is provided by 4 MW klystrons, and then split to 4 or 6 cavities. To avoid oscillations induced by Lorenz-force detuning, the cavities will be stiffened, and each arm of the RF splitting will be equipped with high-power phase shifters acting as fast phase and amplitude modulators [16]. Thanks to the higher gradients and longer cryomodules, the second version of the SPL is 340 m shorter than the initial one (430 m instead of 770 m length), even though it accelerates up to 3.5 GeV instead of 2.2 GeV. A schematic layout of the SPL (CDR2) is shown in Fig. 7.



Figure 7: Schematic layout of the SPL

Table 3 compares the SPL beam parameters for three cases, CDR1, CDR2 and a CDR2 design extended to 5 GeV. The parameters of the two superconducting sections of SPL are reported in Table 4.

Table 3: SPL Beam parameters for three configurations

Design		CDR1 (2000)	CDR2 (2006)	CDR2+
Energy	GeV	2.2	3.5	5
Beam power	MW	4	4	4
Rep. frequency	Hz	75	50	50
Protons / pulse	10^{14}	1.5	1.4	1.0
Av. pulse current	mA	11	40	40
Chopping ratio	%	62	62	62
Pulse length	ms	2.2	0.57	0.4
Bunch frequency	MHz	352.2	352.2	352.2
Length	m	690	430	535
Peak RF power	MW	32	162	220

Table 4: SPL superconducting section parameters

Design β	0.65	1	
Energy	180-643	643-3562	MeV
No. of cavities	42	136	
No. of klystrons	7	32	
No. of cryostats	7	17	
Gradient E_{acc}	19	25	MV/m
Length	85.8	256.1	m

It must be noticed that the CDR2 SPL design is specifically aimed at two high-intensity users, Radioactive Ion Beam physics and neutrino physics, which require a maximum beam power of 4 MW. However, a first implementation of the SPL for the needs of the LHC would be made at the reduced duty cycle required by the new injectors. The potential would be there for high-power operation, but it would be used only at a later stage, according to the programmes of the different communities. In case no future high-intensity application is considered, a Rapid-Cycling Synchrotron replacing the PS Booster could be a valid alternative to the SPL, although a cost analysis has to be made in detail to validate the economics of this solution.

ACKNOWLEDGEMENTS

This work has profited of the collaboration of many groups and services at CERN and of a large number of international partners. To all of them goes our gratitude. We acknowledge the support of the European Community-Research Infrastructure Activity under the FP6 "Structuring the European Research Area" Program (CARE, Contract No. RII3-CT-2003-506395).

REFERENCES

- [1] LHC Design Report, Volume III, "The LHC Injector Chain", CERN-2004-003, <http://cdsweb.cern.ch/record/823808>.
- [2] F. Ruggiero, W. Scandale, F. Zimmermann (eds.), "2nd CARE-HHH-ADP Workshop on Scenarios for the LHC Luminosity Upgrade - LHC-LUMI-05", Arcidosso, Italy, CERN-2006-008, <http://cdsweb.cern.ch/record/886375>.
- [3] A. Baldini et al., "Beams for European Neutrino Experiments", CERN-2006-005, <http://cdsweb.cern.ch/record/955252>.
- [4] EURISOL Design Study, <http://eurisol.org>.
- [5] M. Benedikt, R. Garoby, F. Ruggiero, R. Ostojic, W. Scandale, E. Shaposhnikova, J. Wenninger, "Preliminary Accelerator Plans for Maximizing the Integrated LHC Luminosity", CERN-AB-2006-018-PAF.
- [6] M. Benedikt, R. Garoby, F. Ruggiero, R. Ostojic, W. Scandale, E. Shaposhnikova, J. Wenninger, "Potential for Neutrino and Radioactive Beam Physics of the Foreseen upgrades of the CERN Accelerators", CERN-AB-2006-019-PAF.
- [7] F. Gerigk, M. Vretenar (eds.), "Linac4 Technical Design Report", CERN-AB-2006-084 ABP/RF.
- [8] F. Gerigk (ed.), "Conceptual Design of the SPL II", CERN-2006-006, <http://cdsweb.cern.ch/record/975366>.
- [9] "The European Strategy for Particle Physics", http://council-strategygroup.web.cern.ch/council-strategygroup/Strategy_Brochure.pdf.
- [10] M. Benedikt, R. Garoby (eds.), "Report of the High Intensity Protons Working Group", CERN-AB-2004-022 OP/RF.
- [11] P.Y. Beauvais, "Recent Evolutions in the Design of the French High Intensity Proton Injector (IPHI)", EPAC'04, Lucerne, July 2004, <http://www.jacow.org>.
- [12] F. Caspers, Y. Cuvet, J. Genest, M. Haase, M. Paoluzzi, A. Teixeira, "The CERN SPL Chopper concept and final layout", EPAC'04, Lucerne, July 2004, <http://www.jacow.org>.
- [13] M. Vretenar, Y. Cuvet, F. Gerigk, M. Pasini, "High Power RF testing of a Cell-Coupled Drift Tube Linac Prototype for Linac4", this conference.
- [14] M. Vretenar (ed.), "Conceptual Design of the SPL", CERN 2000-012, <http://cdsweb.cern.ch/record/489425>.
- [15] P. Zucchelli, A novel concept for a neutrino factory: the beta-beam, Phys. Let. B, 532 (2002) 166-172.
- [16] D. Valuch, H. Frischholz, J. Tückmantel, "First Results with a Fast Phase and Amplitude Modulator for High Power RF Application", EPAC04, Lucerne, July 2004, <http://www.jacow.org>.