

# The ATLAS Level-1 Central Trigger

R.Spiwoks<sup>a</sup>, S.Ask<sup>b</sup>, D.Berge<sup>a</sup>, D.Caracinha<sup>a,c</sup>, N.Ellis<sup>a</sup>, P.Farthouat<sup>a</sup>, P.Gallno<sup>a</sup>, S.Haas<sup>a</sup>,  
P.Klofver<sup>a</sup>, A.Krasznahorkay<sup>a,d</sup>, A.Messina<sup>a</sup>, C.Ohm<sup>a</sup>, T.Pauly<sup>a</sup>, M.Perantoni<sup>e</sup>,  
H.Pessoa Lima Jr.<sup>e</sup>, G.Schuler<sup>a</sup>, J.M.de Seixas<sup>e</sup>, T.Wengler<sup>b</sup>

<sup>a</sup>CERN, Geneva, Switzerland

<sup>b</sup>University of Manchester, Manchester, United Kingdom

<sup>c</sup>University of Lisbon, Lisbon, Portugal

<sup>d</sup>Institute of Nuclear Research, Hungarian Academy of Sciences, Debrecen, Hungary

<sup>e</sup>Federal University of Rio de Janeiro, Rio de Janeiro, Brazil

[Ralf.Spiwoks@cern.ch](mailto:Ralf.Spiwoks@cern.ch)

## Abstract

The ATLAS Level-1 Central Trigger consists of the Muon-to-Central-Trigger-Processor Interface (MUCTPI), the Central Trigger Processor (CTP), and the Timing, Trigger and Control (TTC) partitions of the sub-detectors. The MUCTPI connects the output of the muon trigger system to the CTP. At every bunch crossing it receives information on muon candidates from each of the 208 muon trigger sectors and calculates the total multiplicity for each of six  $p_T$  thresholds. The CTP combines information from the calorimeter trigger and the MUCTPI and makes the final Level-1 Accept (L1A) decision on the basis of lists of selection criteria (trigger menus). The MUCTPI and the CTP provide trigger summary information to the Level-2 trigger and to the data acquisition (DAQ) for every event selected at the Level-1. They further provide accumulated and, for the CTP, bunch-by-bunch counter data for monitoring of the trigger, detector and beam conditions. The TTC partitions send timing, trigger and control signals from the CTP to the sub-detectors and receive busy signals which can throttle the generation of L1As. The Local Trigger Processors (LTPs) normally receive the TTC signals from the CTP but can also generate them locally. The LTP interface (LTPIM) modules allow connecting of several LTPs for combined local running.

The MUCTPI, the CTP and most of the TTC partitions of the ATLAS sub-detectors have been installed in the ATLAS experiment and are being used for commissioning tests with the trigger processors on the input and several sub-detectors as well as DAQ and Level-2 trigger on the output. Results of operating the Central Trigger in the experiment using trigger information from trigger processors connected to sub-detectors observing cosmic rays will be shown.

## I. INTRODUCTION

The ATLAS Level-1 trigger [1] is a synchronous system operating at the bunch crossing (BC) frequency of 40.08 MHz of the Large Hadron Collider (LHC) accelerator. It uses information on clusters and global energy in the calorimeters and on tracks found in the dedicated muon trigger detectors. An overview of the ATLAS Level-1 trigger is shown in Figure 1. The Level-1 central trigger consists of the Muon-to-Central-Trigger-Processor Interface (MUCTPI), the Central Trigger Processor (CTP), and the Timing, Trigger and Control (TTC) partitions.

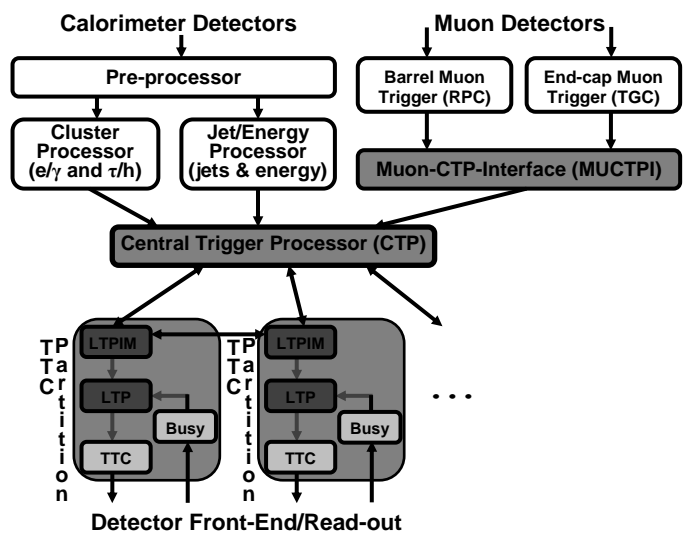

Figure 1: Overview of the ATLAS Level-1 Trigger

The MUCTPI [2] combines trigger information from the two dedicated muon trigger detectors, the Resistive Plate Chambers (RPC) in the barrel and the Thin-Gap Chambers (TGC) in the end-cap region. The CTP [3] forms the Level-1 Decision (accept or not) every BC, and distributes it to the TTC partitions. It also receives timing signals from the LHC and fans them out to the TTC partitions. The TTC partitions perform the distribution of the timing, trigger and control signals to all sub-detector front-end electronics.

In the ATLAS experiment there are about 40 TTC partitions. Each one contains an optional Local Trigger Processor Interface Module (LTPIM) [4], one Local Trigger Processor (LTP) [5], a TTC system proper, and a busy tree. The TTC system proper [6] encodes the signals received from the CTP. It converts them into optical signals and fans them out to the detector front-end electronics. The busy tree is a fast feedback tree for the front-end electronics in order to throttle the generation of Level-1 Accept (L1A) decisions. It is based on the ATLAS Read-out Driver Busy (ROD\_BUSY) module [7].

## II. THE MUCTPI

The MUCTPI receives the muon candidates from all 208 trigger sectors, calculates multiplicities for six programmable  $p_T$  thresholds and sends the results to the CTP. It resolves cases where a single muon traverses more than one sectors and thus avoids double counting. The MUCTPI sends summary information to the Level-2 trigger and to the data acquisition (DAQ). It identifies, in particular, regions of interest (RoI) for the Level-2 trigger processing. The MUCTPI can also take snapshots of the incoming sector data for diagnostics and accumulate rates of incoming muon candidates for monitoring.

The MUCTPI is implemented as a single-crate 9U VMEbus system with three different types of modules and a dedicated backplane as shown in Figure 2.

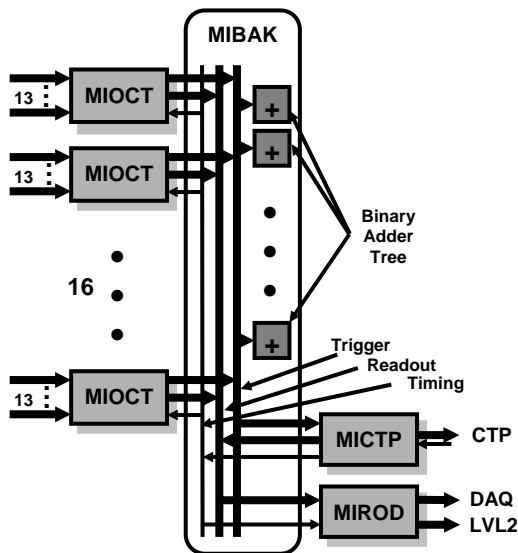

Figure 2: Overview of the MUCTPI

The octant module (MIOCT) receives the muon candidates from the trigger sector logic and resolves overlaps. The dedicated backplane (MIBAK) performs the multiplicity summing, the readout transfer and the timing signal distribution. The CTP interface module (MICTP) receives timing and trigger signals from the CTP and sends multiplicities to the CTP. The readout driver module (MIROD) sends summary information to the Level-2 trigger and the DAQ.

A prototype of the MUCTPI was installed in the experiment in 2005. It provides almost full functionality and misses only some flexibility in the overlap handling. The MUCTPI is being upgraded incrementally to the final system. Figure 3 shows the setup in the experiment with two old MIOCTs, and one new MIOCT. The new MIOCTs design provides more flexible overlap handling. The prototype has been tested and is being used in the experiment. The final production of 34 modules is expected for September 2007; see also Reference [2].

The MIROD and MICTP modules are being re-designed. The old MIROD was developed for an old version of the ATLAS S-Link readout link (ODIN). It can be used with the

ATLAS standard version of S-Link readout link (HOLA) [8] using an adaptor card. This requires more space than will be available in the final system when all 16 MIOCTs will be present. A new MIROD design became necessary. At the same time a more recent FPGA technology could be used and the original design could be migrated into a single FPGA. It was found that the same PCB could be used for the MICTP so that spare modules will be provided based on the new combined design. A prototype is currently at manufacturing; see also Reference [2].

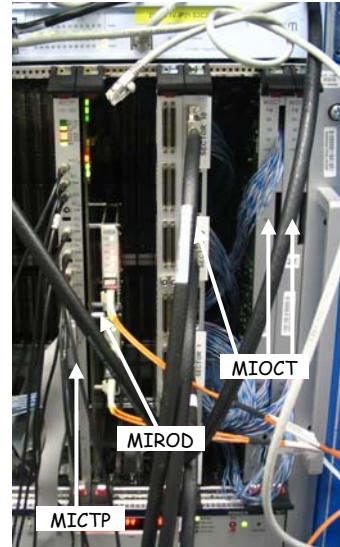

Figure 3: The MUCTPI in ATLAS

## III. THE CTP

The CTP receives, synchronizes and aligns trigger inputs from calorimeter and muon triggers, and others. It generates the Level-1 Accept (L1A) according to a programmable trigger menu. The CTP has, in addition, the following functionality: it generates a trigger-type word accompanying every L1A; it generates preventive dead time in order to prevent front-end buffers from overflowing; it generates summary information for the Level-2 trigger and the DAQ; it generates a precise time stamp using GPS and with precision of 5ns; it generates other timing signals like the Event Counter Reset (ECR). The CTP can take snapshots of the incoming trigger inputs for diagnostics and accumulate rates of incoming trigger inputs and internally generated trigger combinations for monitoring.

The CTP is implemented as a single-crate 9U VMEbus system with six different types of modules and three dedicated backplanes as shown in Figure 4. The machine interface module (CTPMI) receives timing signals from the LHC. The input module (CTPIN) receives trigger input signals and synchronizes and aligns them. The monitoring module (CTPMON) performs bunch-per-bunch monitoring. The core module (CTPCORE) forms the L1A and sends summary information to the Level-2 trigger and the DAQ. The output module (CTPOUT) sends timing signals to the TTC Partitions and receives calibration requests. The calibration module (CTPCAL) time-multiplexes the calibration requests and receives additional front panel inputs. The Pattern-In-Time

(PIT) bus transports the synchronized and aligned trigger signals from the CTPINs to the CTPCORE and the CTPMON. The common (COM) bus contains timing signals. The calibration (CAL) bus transports the calibration requests from the CTPOUTs to the CTPCAL.

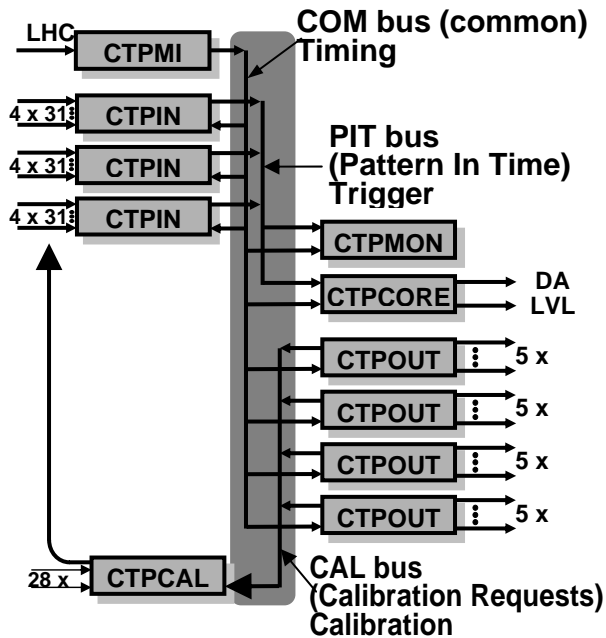

Figure 4: Overview of the CTP

The final CTP was installed in the experiment in 2006. Figure 5 shows the CTP with one CTPMI, three CTPINs, one CTPMON, one CTPCORE, four CTPOUTs, and one CTPCAL. There is an additional NIM-to-LVDS fan-in module for receiving NIM trigger signals and routing them to one of the CTPINs. The CTPCAL module was the last one to be produced. Two more complete systems are available in the laboratory for spare and for development, mainly firmware modification and software development.

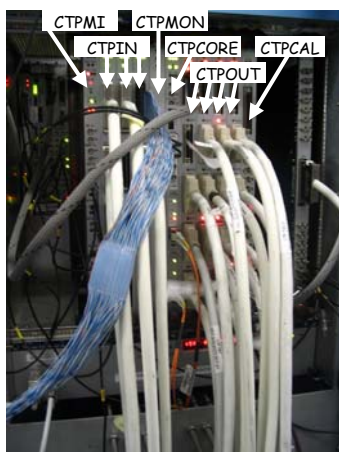

Figure 5: The CTP in ATLAS

#### IV. THE LTP AND LTPIM

The LTP connects to the CTP and allows to daisy-chain several LTPs. It replaces the CTP when in stand-alone mode.

It then receives the timing and trigger signals from local external signals or generates them from its internal pattern generator.

The LTPIM is a switch module for the LTP signals. It has three inputs (from CTP and from another LTPIM, as well as a local NIM input), and three outputs (to another LTP and another LTPIM, as well as a local NIM output). As shown in Figure 6 it allows several combinations of sub-detectors to run in stand-alone mode with one LTP being the master instead of the CTP. These combinations can be changed by reprogramming the LTPIMs and do not require any re-cabling. An example of such a combination of sub-detectors is the calorimeters and the calorimeter trigger.

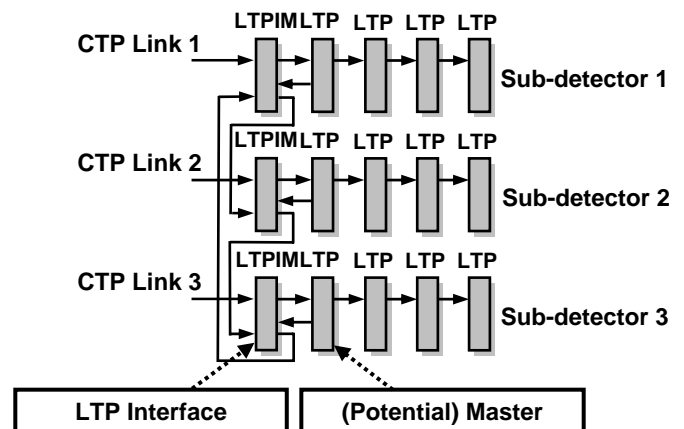

Figure 6: Overview of the LTP and LTPIM

The LTP is already used in the experiment. The last kind of module built is the LTPIM. A prototype has been tested, see Figure 7. The final production of 34 modules is expected for October 2007.

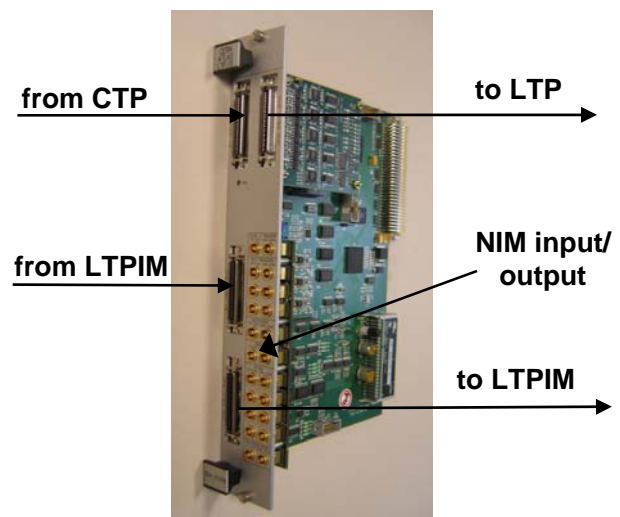

Figure 7: The LTPIM Prototype

#### V. COMMISSIONING

The MUCTPI, the CTP and the LTPs have been used routinely since more than one year in order to provide triggers to an increasing number of sub-detectors in ATLAS. They are

mainly using muon trigger (barrel and end-cap), some temporary local triggers and CTP internal triggers. Basic connection tests to the calorimeter trigger have been performed. The timing and trigger signals are provided to 14 sub-detectors. In addition, to the routine running, several milestone weeks during 2007 are organised in order to achieve combined running of all sub-detectors, triggers and DAQ. The last milestone week “M4” took place from 23 August to 3 September.

### A. Setup

The setup of the Level-1 central trigger is shown schematically in Figure 8. Four barrel trigger sectors and six end-cap trigger sectors provided muon candidates to the MUCTPI. In addition, a temporary hadron calorimeter cosmic trigger and CTP internal triggers were sent to the CTP. The calorimeter trigger was in preparation. Both, MUCTPI and CTP, provided summary information to the Level-2 trigger and the DAQ. The timing and trigger signals were distributed to almost all sub-detectors.

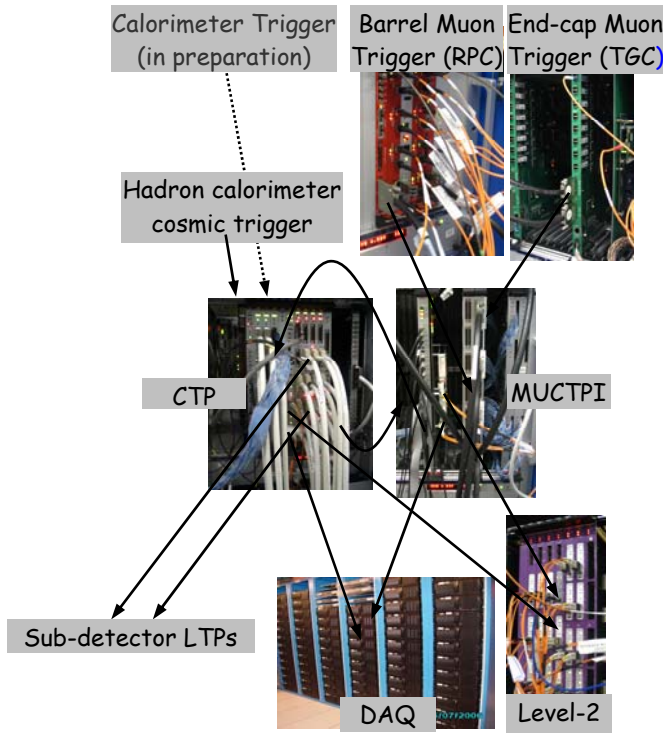

Figure 8: The Setup of the Level-1 Central Trigger during the last Milestone Week

### B. Software

The Level-1 central trigger uses the ATLAS configuration database and run control system [9]. For each module a database schema for the configuration information and a plug-in module for the control have been developed. Several monitoring tasks and graphical user interfaces have been developed for monitoring of input rates, of bunch-per-bunch rates, of combined trigger rates and of the busy status. Others are in preparation.

The trigger configuration [10] is stored in the Trigger Database which contains the full event selection strategy. That strategy contains, in addition to the Level-1 trigger menu, the Level-2 trigger and Event Filter selections. The Trigger Tool is a graphical user interface for browsing and editing of all trigger menus. In order to automatically translate the high-level description of the Level-1 trigger menu into all necessary configuration files of the CTP, the Trigger Menu Compiler has been developed. It takes an XML file as input and generates the VHDL files for the switch matrices of the CTPINs and the memory files of the CTPCORE look-up tables and content-addressable memories. Some of these details are shown in Figure 9.

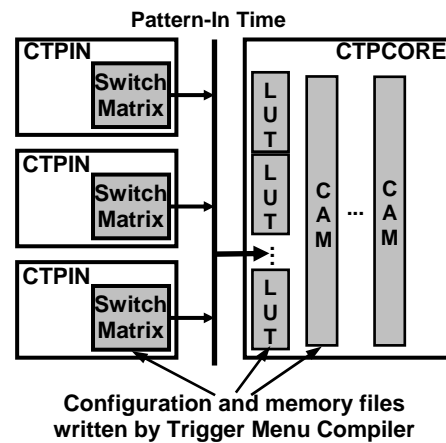

Figure 9: The Configuration generated by the Trigger Menu Compiler

### C. Results

The Level-1 central trigger has been generating LIAs for the ATLAS sub-detectors. Figure 10 shows a sample display of an event triggered by the end-cap muon trigger with hits in the muon precision chambers.

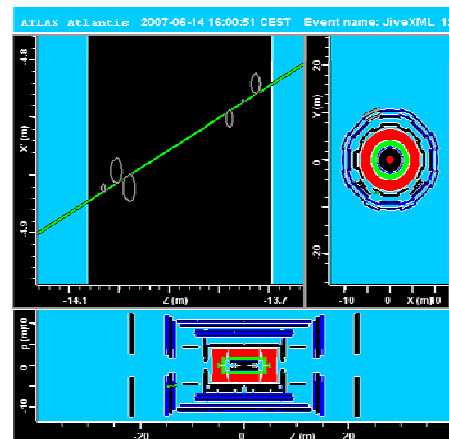

Figure 10: Event display of a Cosmic Muon triggered by the Level-1 Central Trigger

## VI. CONCLUSION

The Level-1 central trigger hardware is finished or about to be finished. The only missing modules are the following: the new MIOCT prototype was tested and the final production is under way; the new MIROD/MICTP prototype is being built; the LTPIM prototype has been tested and the final production is under way. The complete trigger and readout chain is being operated in the experiment using cosmic rays. The effort is now moving towards exploitation and operation. Some work on the online and offline software, e.g. for monitoring, is still going on.

## VII. REFERENCES

- [1] The ATLAS Collaboration, “*First-level Trigger Design Report*”, CERN/LHCC/1998/014, June 1998.
- [2] S. Haas *et al.*, “*The ATLAS Level-1 Muon to Central Trigger Processor Interface*”, these proceedings.
- [3] R. Spiwoks *et al.*, “*The ATLAS Level-1 Central Trigger Processor (CTP)*”, 11<sup>th</sup> Workshop on Electronics for LHC and Future Experiments, CERN/LHCC/2005/038 265, November 2005.
- [4] D. Caracinha, P. Farthouat *et al.*, «*The Local Trigger Processor Interface Module*», 12th Workshop on Electronics for LHC and Future Experiments, CERN/LHCC/2007/006 494, January 2007.
- [5] P. Amaral *et al.*, “*The ATLAS Local Trigger Processor (LTP)*”, IEEE Trans. Nucl. Sci. **52** (2005) 1201.
- [6] S. Baron *et al.*, “*Trigger, Timing and Control System (TTC) for the LHC*”, <http://ttc.web.cern.ch>.
- [7] P. Gallno *et al.*, “*The ATLAS ROD\_BUSY Module MkII*”, <http://edms.cern.ch/item/EDA-00510>.
- [8] E. v.d. Bij, S. Haas *et al.*, “*CERN S-Link Home Page*”, <http://hsi.web.cern.ch/HSI/s-link>.
- [9] S. Gameiro *et al.*, “*The ROD Crate DAQ Software Framework of the ATLAS Data Acquisition*”, IEEE Trans. Nucl. Sci. **53** (2005) 907.
- [10] R. Spiwoks *et al.*, “*Configuration of the ATLAS Trigger*”, 11<sup>th</sup> Workshop on Electronics for LHC and Future Experiments, CERN/LHCC/2005/038 269, November 2005.