



CM-P00063009

REVISION NO. 2 OF THE PROPOSAL TO THE ISR

CERN/ISR/70-19

Cern - ISR/70-19 /

Rev. 2

PART I

SEARCH FOR HIGH ENERGY MULTIGAMMA EVENTS;

POSSIBLE CONSEQUENCE OF MAGNETIC MONOPOLE PAIRS OR OF HIGH Z LEPTONS

Luke C. L. Yuan, G. F. Dell, H. Uto, and C. L. Wang  
Brookhaven National Laboratory  
Upton, New York

John P. Docher  
Grumman Aerospace Corporation  
Bethpage, New York

E. Amaldi, M. Beneventano, B. Borgia, and P. Pistilli  
Istituto di Fisica 'Guglielmo Marconi'  
Universita Degli Studi - Roma, Italy

I. INTRODUCTION

Several cosmic-ray experiments involving the exposure of photographic emulsions at high altitudes have shown the existence of high energy multi-gamma-ray events.<sup>1</sup> These events could not be accounted for by conventional electromagnetic showers originating from a single high energy gamma. Rather they appear to be a result of a large number of gammas produced simultaneously from a single interaction. These events remained a mystery for a number of years until recently when Ruderman and Zwanziger<sup>2</sup> put forward a plausible explanation which attributes these high energy multi-gammas as due to the creation and subsequent annihilation process of magnetic monopole pairs. The important point, which has been emphasized by Ruderman and Zwanziger and also by Teller,<sup>3</sup> is that when a pair of monopoles are produced they will rapidly annihilate ( $t \sim 10^{-22}$  sec) due to the very strong

coulomb attraction and will leave behind remnant photons. The multiplicity of these photons is expected to be large ( $\sim 1/\alpha$ ). Therefore, with energies available at ISR, the production of free monopole pairs would be less probable than the characteristic annihilation processes, either real or virtual. Very recently, T. D. Lee<sup>4</sup> suggested that another possible process which involves the creation of pairs of highly charged leptons ( $Z > 10$ ) can also be responsible for these multigamma events discussed above. In fact, any charged particle with a very strong electromagnetic coupling would yield such events.<sup>4</sup> In the event obtained by deBenedetti, there were 14 gammas with a total energy of  $> 40$  GeV.

The primary objective of the present proposal is to search for high energy multigamma events at the ISR and to study the characteristics and nature of these multigammas in order to gain a better understanding of the origin of such processes. We would also try to ascertain whether or not magnetic monopoles or high  $Z$  leptons are responsible for them.

A secondary objective is to simultaneously search for individual monopoles that might be created by the colliding beams. Even if none of these not yet confirmed processes takes place in nature at ISR energies, the amount of experimental information that would be collected, especially the  $\pi^0$  production and  $\pi^0, \pi^c$  correlation data, would constitute a significant return for the effort invested in this research.

A detailed discussion of the various possibilities for multigamma production in p-p collisions is presented in the accompanying document, "A Few Considerations Concerning the Search for Multigamma Rays Events Produced in Proton-Proton Collisions." In the following discussion a short summary is presented.

A possible mechanism for the production of high multiplicity  $\gamma$ -ray events in proton-proton collisions is the following process:

$$p_1 + p_2 \rightarrow \text{hadrons} + \gamma' \quad (1)$$

$$\gamma' \rightarrow n\gamma \quad (1')$$

In Eq. (1),  $p_1, p_2$  are colliding protons and  $\gamma'$  is a time-like virtual photon with momentum  $q$  which subsequently decays into  $n\gamma$ . A possible Feynman diagram for  $\gamma'$  is shown in Fig. 1.

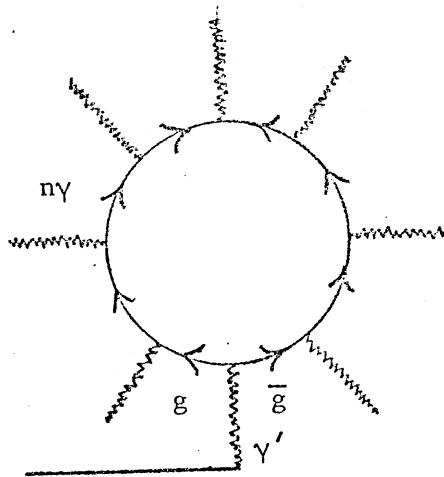

Fig. 1

The particle,  $g$ , propagating around the loop in Fig. 1 is presumed to have a very strong interaction with the photon field ( $g^2/\hbar c \sim 1/\alpha$ ) so that the photon multiplicity which is proportional to  $g^2/\hbar c$  is large. It is important to note that this effect can be felt even below threshold for  $g, \bar{g}$  production. The most obvious candidate for  $g$  is the Dirac magnetic monopole which has been shown by Dirac to have a coupling strength of  $\frac{1}{\alpha} \frac{n^2}{4}$  where  $n$  is an integer. However, as mentioned previously, a highly charged lepton or any particle with a similar very strong electromagnetic interaction will yield a multigamma event.

The expected average energy and angular distribution of the  $n\gamma$ 's is derived by assuming that the photons are isotropic and of equal energy in the rest frame of the virtual photon. Transforming to the center of mass of the colliding protons (which is essentially the lab frame for ISR) yields the laboratory energy and angular distribution of the photons for various values of  $q^2$ . We will examine large  $-q^2$ . However, we do not necessarily require  $-q^2 \geq 4m^2g$  which is the threshold for  $g, \bar{g}$  production since the effect can be felt for  $-q^2 < 4m^2g$  and in fact the transition from below threshold to above threshold may only involve a cusp effect in the  $n\gamma$  cross section and would not necessarily imply a significant enhancement of the  $n\gamma$  cross section. The expected energies of the photons will be from a few hundred MeV to a few GeV. These photons will be distributed over a significant part of the available  $4\pi$  geometry. In particular, at the maximum  $q^2$  they will be distributed isotropically. For lower values of  $q^2$ , some collimation about one of the protons is expected with half the photons in a narrow cone ( $\tan\theta \sim 1/\gamma\beta$  where  $\beta$  is the velocity of the  $q \geq 0$  frame and  $\gamma$  the corresponding Lorentz factor), and the rest in a diffuse cone. It is clear that for large  $-q^2$ , these cones cover a large solid angle. We would expect these cones are appreciably larger than the cones for pion production.

If these multigamma events are seen, then the question arises as to whether they are induced by magnetic monopoles or by particles such as leptons with high  $Z$ . The angular distribution could be an important factor in answering this question since the parity of a photon emitted by a monopole is opposite to that of a photon emitted by a particle with an electric charge. Therefore the photon propagator between the proton and the

monopole in the loop will lead to pseudoscalar terms in the differential cross section. This should lead to a different angular distribution of multigammas induced by monopoles than for multigammas induced by high Z leptons.<sup>5</sup>

There is no way of reliably estimating the cross section for the process under investigation. The process (1) has been studied theoretically and experimentally, though not at the energies and  $q^2$  values available at ISR.<sup>6-9</sup> For (1') there is no way of obtaining a reliable estimate because of the large coupling. Therefore, for the purposes of estimation, it is simplest to assume that:

$$\frac{d\sigma}{dq^2} \frac{g}{g} (q^2, E) \sim K \frac{d\sigma}{dq^2} \mu^+ \mu^- (q^2, E) \quad (2)$$

where K is a constant. Equation (2) takes into account the hadronic structure and the constant K is the ratio of the coupling  $[(\gamma' \rightarrow g\bar{g})/(\gamma' \rightarrow \mu^+ \mu^-)]^2$ . If we interpret these couplings as dissociation probabilities as suggested by Goto,<sup>10</sup> then the maximum value of K is  $1/\alpha$ . Therefore, the total cross section for  $n\gamma$  production would be  $10^{-34} \text{ cm}^2$  for  $-q^2 > 16(\text{GeV})^2$ . The same scheme has been worked out in more detail by N.Cabibbo and M.Testa, who start with process (1) plus (1') and uses for K the upper limit derived in the accompanying document (A Few Considerations Concerning the Search for Multigamma Rays Events Produced in Proton-Proton Collisions) and extrapolates the Lederman data from  $E_{\text{lab.}} = 29 \text{ GeV}$  to the ISR energy ( $E_{\text{lab.}} \sim 1.8 \times 10^{-12} \text{ eV}$ ) by using a simplified formula derived by Altarelli et al.<sup>9</sup> which fits satisfactorily

the experimental data

$$\frac{d\sigma_{\mu^+\mu^-}}{dM_{\mu^+\mu^-}} = \frac{1}{6} \frac{10^{-33}}{M_{\mu^+\mu^-}^2} s \left( 1 + \frac{M_{\mu^+\mu^-}^2}{s_0} \right) \left( 1 - \frac{M_{\mu^+\mu^-}^2}{s} \right)^{\frac{1}{2}} \text{ cm}^2/\text{GeV} \quad (3)$$

$$\text{where } M_{\mu^+\mu^-} = \sqrt{-q^2}$$

The main difference between this estimate and the first one is that in the latter one assumes  $d\sigma_{\mu^+\mu^-}/dM_{\mu^+\mu^-}$  to be weakly dependent on  $s$ ,<sup>7,8</sup> for  $M_{\mu^+\mu^-}^2/s < 1$ , while Eq. (3) contains a factor of  $s$  which leads to a value of  $d\sigma_{gg}/dq^2$  about 40 times higher.

An estimate based on the Weizsacker-Williams approach in which multi-gammas are produced by collisions of the coulomb-field of the colliding photon yields a much larger cross section ( $10^{-28} \text{ cm}^2$ ).

## II. EXPERIMENTAL PROCEDURE

### a) Detection of Multigamma Events

The basic requirement of our detection system is the capability to distinguish between a multigamma event and conventional high energy showers such as those from the decay of multiple  $\pi^0$ 's. The former is characterized by the simultaneous appearance of a large number of energetic showers, while the latter is characterized by showers accompanied by a number of charged particles. Furthermore, in the case of showers from  $\pi^0$ 's, the average pion transverse momentum is restricted, therefore, the angular distribution of these showers can be quite different from that of the multigamma events. Our detection system is designed to record the development of each shower by measuring the energy deposition during its development.

A sketch of our detector system showing both the plan view and the side view is shown in Fig. 2. The sketch is approximately in scale and the dimensions of the detector units are indicated. A cross-sectional view of the

detector unit is shown in Fig. 3. The detector unit is designed to make sure that the showers due to incident photons are developed in the lead glass. The first two layers of the detector unit are thin scintillation and Cerenkov counters. The main portion of the detector unit consists of wire proportional chambers interspersed with lead-glass hodoscope elements ( $2'' \times 4'' \times 20''$  or  $4'' \times 4'' \times 20''$ ) with the exception that  $W_c$  and  $W_t$  are chambers operated in the saturated mode. The total thickness of each detector unit is  $\sim 20''$  providing a total of 16 radiation lengths of lead glass. The detector arrangement shown in Fig. 2 consists of ten such units, which covers 60% of total solid angle.

The occurrence of multigamma events is established by the requirement that at least 24 wires among the chambers  $W_t$  in all units fire (equivalent to  $\sim 24$  or more simultaneous gamma rays). Chambers  $W_c$  identify the number of charged particles and veto the system when there are more than several charged particles. The normal  $\pi^0$  background events are rejected by  $W_c$ , because they always are accompanied by charged particles (see Appendix). Wire chambers determine the positions of the showers, whereas the lead-glass counter hodoscopes together with wire chambers determine the energy of each shower. The scintillation counter S and wire chamber  $W_c$  monitor the incident charged particles. A block diagram of the logic system is shown in Fig. 4. Chambers  $W_c$  and  $W_t$  in coincidence give an event signal to trigger the system. The number of charged particles and gammas are registered in shift registers. Pulse height and position information from counters and chambers are obtained with sample-and-hold units, analogue multiplexer and analogue-to-digital converter.

A high multiplicity  $\pi^0$  event could be confused with a monopole induced multigamma event. This background can be reduced by restricting the charge

multiplicity to as small a value as possible while at the same time setting the threshold for  $\gamma$  multiplicity to a high value such as 24 (actually the expected multiplicity is  $\sim 1/\alpha$ ). We assume the hadron multiplicities obey Poisson distributions. The average  $\pi^0$ ,  $\pi^+$ ,  $\pi^-$  multiplicity is approximately 6 at ISR energies. The probability for producing the average number of  $\pi^0$ 's and no charged particles is down by a factor of  $10^{-4}$  from the probability for producing the average number of charged particles. In addition, the probability of producing  $12\pi^0$  is  $10^{-3}$  times the average. This provides a total factor of  $10^{-7}$  or a cross section of  $3 \times 10^{-33} \text{ cm}^2$ . Of course, this cross section is rapidly reduced even more than when multiplicities greater than 12 are considered. A detailed discussion of this matter is given in the Appendix. In addition, we shall observe mostly large angle high multiplicity  $\gamma$  events. Since the average pion transverse momentum is restricted, the selection of large angle events reduces the background by an additional estimated two orders of magnitude. Therefore, a rejection ratio of  $10^9$  should be readily obtainable. This is the case assuming a significant percentage of the monopole induced  $\gamma$ 's occur at large angles. In a careful data analysis, additional background rejection can be obtained.

The number of  $\pi^0$  background events is expected to decrease rapidly as the number of  $\pi^0$ 's increases. An enhancement at a large number of simultaneous showers ( $> 24$ ) would be a strong indication of the existence of multigamma events.

The cross section for pp interactions is  $\sim 30 \times 10^{-27} \text{ cm}^2$ . Therefore, the average event rate is  $10^5/\text{sec}$ . Since the time resolution of our system is  $\sim 10 \text{ nsec}$ , the probability of having several pp interactions within this



time resolution is very small. (The probability of having even two pp interactions within the time resolution is down by a factor of  $10^3$ .) The trigger conditions mentioned earlier will reduce this probability by an additional factor of  $10^9$ . Background events due to gas scattering are estimated to be lower than the  $\pi^0$  background and also these gammas are of very low energy.

Particles incident from directions other than that of the interaction region could be rejected by monitoring anticounters positioned around the detector.

b) Free Monopoles

It is less probable to produce free monopoles than a monopole pair which annihilates immediately. However, if a free monopole is produced with sufficient momentum and if thin windows can be provided it can pass through the vacuum chamber and give a large signal in the thin scintillation and Cerenkov counters. The ratio of these two signals is different for a monopole and high Z particle.<sup>10</sup>

III. EXPECTED EVENT RATES

With the design luminosity of  $4 \times 10^{30} \text{ cm}^{-2} \text{ sec}^{-1}$ , the number of multigamma events per day is

$$N = L\sigma t = 3.5 \times 10^{35} \sigma \quad (4)$$

where  $\sigma$  is the total cross section for multigamma production and  $t$  is the time in seconds.

If one assumes a production cross section of  $10^{-34} \text{ cm}^2$ , which we feel is conservative (in fact the estimated range is  $10^{-28} - 10^{-34} \text{ cm}^2$ ), then with a collection efficiency of 75% one would expect to obtain 3000 events in 100 days.

IV. CONCLUSION

The proposed experiment will enable us to obtain quantitative information on the production of energetic multigamma events in p-p collisions in an energy region attainable previously only in cosmic radiation. The meager data obtained in cosmic ray experiments shows the existence of anomalous energetic multigamma rays which can be attributed to the creation and subsequent annihilation of magnetic monopole pairs or high Z lepton pairs. In fact, as recently suggested by T. D. Lee, it is even possible that these anomalous multigamma events could be attributed to a hadronic reaction in which a particle excited to an extraordinarily high angular momentum state is produced and subsequently decays stepwise with the emission of many gamma rays. Certainly this domain is completely unexplored and it would be very important to have quantitative information on multigamma events in p-p collisions. Furthermore, the necessity of understanding the background produced by the decay of multiple  $\pi^0$ 's will provide us with information concerning the correlation mechanism in pion production.<sup>12</sup>

APPENDIX

THE  $\pi^0$  BACKGROUND PROBLEM

Because of the fact that the multi- $\gamma$  production rate in p-p collisions could be quite small ( $\sigma \sim 10^{-34} \text{ cm}^2$ ), it is necessary to estimate the production rate of high multiplicity  $\pi^0$  events because of their prompt decay into 2  $\gamma$ -rays they could be confused with monopole induced multi- $\gamma$  events. We first must choose a reasonable model for pion production in p-p collisions since there is at present very little reliable data on high multiplicity  $\pi^0$  events. In general, if there is some simple dynamical mechanism operating in the production of pions (as we would certainly expect), then there would be strong correlations between the number of  $\pi^0$  and  $\pi^+$ ,  $\pi^-$  mesons in a p-p collision. For example, if pions were produced via emission and decay of  $\rho$  mesons, there would be no way of producing a large number of  $\pi^0$ 's with no accompanying charged pions. Therefore, to cut down the number of high multiplicity  $\pi^0$  events, the total charge of the collision process should be restricted to as low a value as possible (e.g.  $2e$ ). We next discuss the reduction in  $\pi^0$  background which ensues.

Recently, the multiperipheral model has had considerable successes in predicting multiplicities of pion production reaction.<sup>13</sup> This model predicts a Poisson distribution for pion multiplicities. A logical extension of this model, constructed by Caneschi and Schwimmer,<sup>12</sup> is to correlate  $\pi^0$ ; and  $\pi^+$ ,  $\pi^-$  multiplicities by assuming the pions are produced by the decay of  $\rho$  mesons and  $\sigma$  mesons emanating from the multiperipheral

chain. The production of  $\rho$ 's and  $\sigma$ 's follows the Poisson distribution law. Under these assumptions, the cross section for producing  $N$   $\pi^0$  mesons with no accompanying charged mesons is given by

$$\sigma = \frac{\sigma_0 \left(\frac{1}{3}\right)^{N/2} \left(\frac{\bar{N}}{2}\right)^{N/2} e^{-3\bar{N}/2}}{\left(\frac{N}{2}\right)!} \quad (A)$$

In Eq. (A),  $\sigma_0$  is the total inelastic cross section ( $\sim 30$  mb),  $\bar{N}$  is the average  $\pi^0$  multiplicity (which is  $\sim 6$  at ISR energies) and  $N$  is the number of  $\pi^0$  mesons produced in a specific event. Equation (A) is essentially the production cross section for  $N/2$   $\sigma$  mesons via the multi-peripheral model multiplied by the probability for each of these  $\sigma$ 's to decay into  $2\pi^0$ 's [ $\sim (1/3)^{N/2}$ ]. In Table I the ratio  $\sigma_N/\sigma_0$  is calculated for several  $\pi^0$  multiplicities. It is important to note that the numbers in Table I decrease very rapidly with increasing  $N$ . They can be reduced further by looking for wide angle  $\gamma$ 's since the  $\pi^0$  mesons should be collimated due to expected factors of the form  $e^{-P_\perp/P_\perp^0}$  in the differential cross section for  $\pi^0$  production where  $P_\perp$  is the transverse momenta and  $P_\perp^0 \sim 150$  MeV. If the monopole-induced multigamma events are produced with a cross section in the range  $10^{-34} - 10^{-36} \text{ cm}^2$  it would seem that a multiplicity distribution, peaking somewhere around  $N \sim 100$ , should clearly be visible above the  $\pi^0 - \gamma$  background. (See Fig. 5.) Here the broken line shows the total  $\pi^0 - \gamma$  background, whereas the dotted line shows the  $\pi^0 - \gamma$  background for angles greater than  $20^\circ$  with respect to the proton direction.

TABLE I

$\frac{\sigma_N}{\sigma_0}$	N (No. of $\pi^0$ 's)
$1.7 \times 10^{-7}$	12
$3.0 \times 10^{-10}$	16
$3.3 \times 10^{-12}$	20
$2.5 \times 10^{-14}$	24
$1.37 \times 10^{-16}$	28
$5.7 \times 10^{-19}$	32
$1.9 \times 10^{-21}$	36
$5.0 \times 10^{-24}$	40
$1.1 \times 10^{-26}$	44
$2.0 \times 10^{-29}$	48
$3.1 \times 10^{-32}$	52

REFERENCES

1. M. Schein, et al., Phys. Rev., 95, 855 (1954).  
A. DeBenedetti, et al., Nuovo Cimento, 2, pp. 220-230 (1955).  
A. DeBenedetti, et al., Nuovo Cimento, 12, pp. 954-956 (1954).  
M. Koshiha and M. E. Kaplan, Phys. Rev., 100, 336 (1955).
2. M. Ruderman and Zwanziger, Phys. Rev. Letters, 22, 146 (1969).
3. See footnote in G. Wentzel Supplement Progress of Theoretical Physics, No. 37-38, p. 163 (1966).
4. T. D. Lee Private Communication.
5. See S. Weinberg, Phys. Rev., 138B, 988 (1965);  
J. Schwinger, Phys. Rev., 151, 1048 (1966), for discussions of the parity properties of electric-magnetic monopole correlation terms.
6. J. H. Christenson, G. S. Hicks, L. M. Lederman, P. J. Limon, B. G. Pope, and E. Zavattini, Bull. Amer. Phys. Soc., 15, 579 (1970).
7. S. Berman, D. Levy, and T. Neff, Phys. Rev. Letters, 23, 1363 (1969).
8. Sidney D. Drell and Tung MowYan, Phys. Rev. Letters, 25, 316 (1970).
9. G. Altarelli, R. A. Brandt, and G. Preparata, Phys. Rev. Letters, 26, 42 (1971).
10. E. Goto, H. Kolm, K. W. Ford, Phys. Rev., 132, 387 (1963).
11. D. R. Tompkins, Phys. Rev., 140B, 443 (1965).
12. L. Caneschi and A. Schwimmer, SLAC-PUB-829, ITP-373, Nov. 1970.
13. G. F. Chew and A. Pignotti, Phys. Rev., 176, 2112 (1968).

Fig. 2 Experimental Setup.

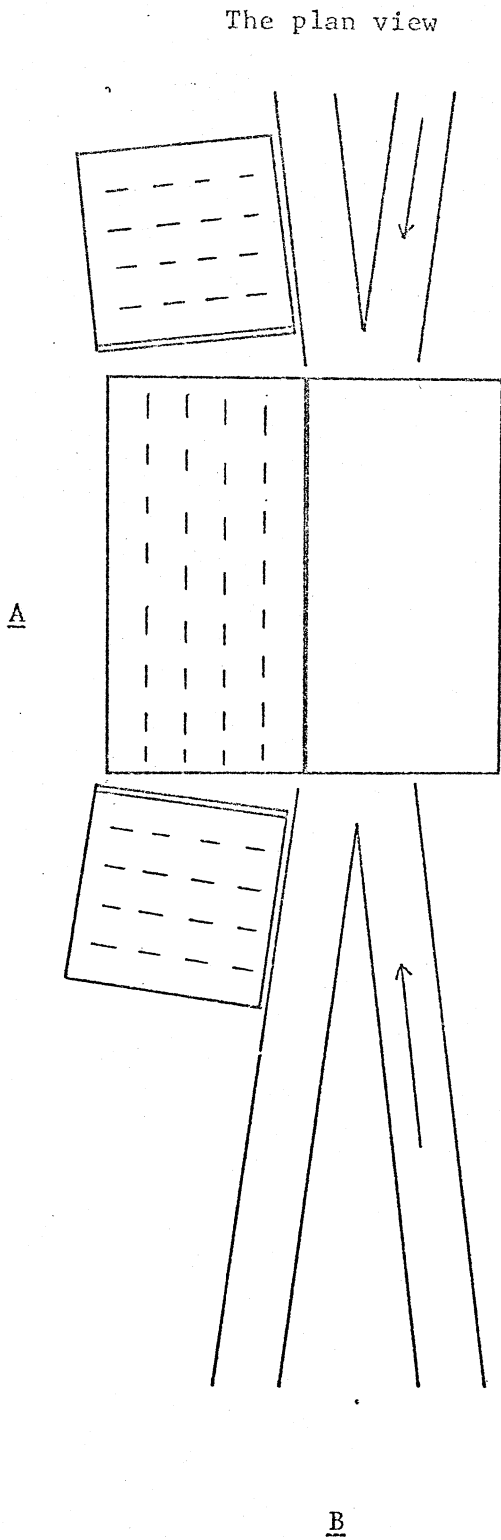

The side view from the point A

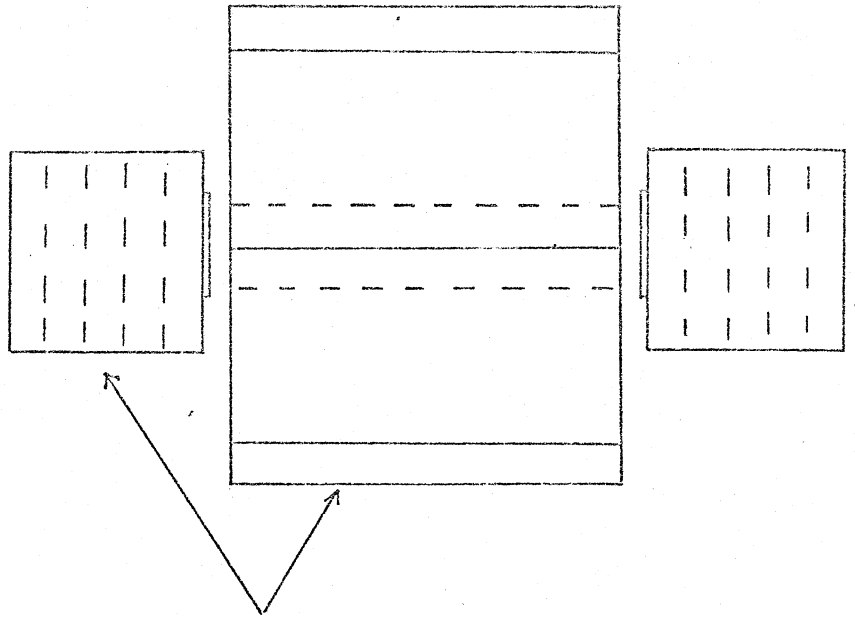

Details of detector unit are shown in Fig. 3.

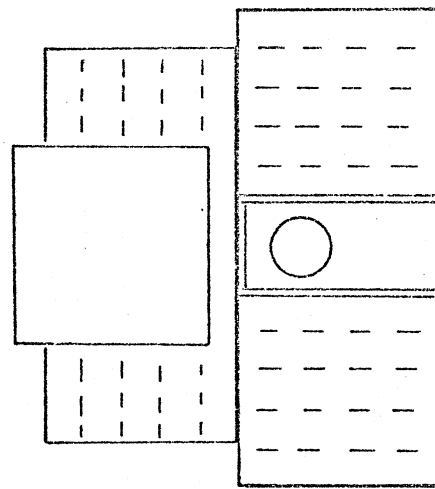

The side view from the point B

50 cm

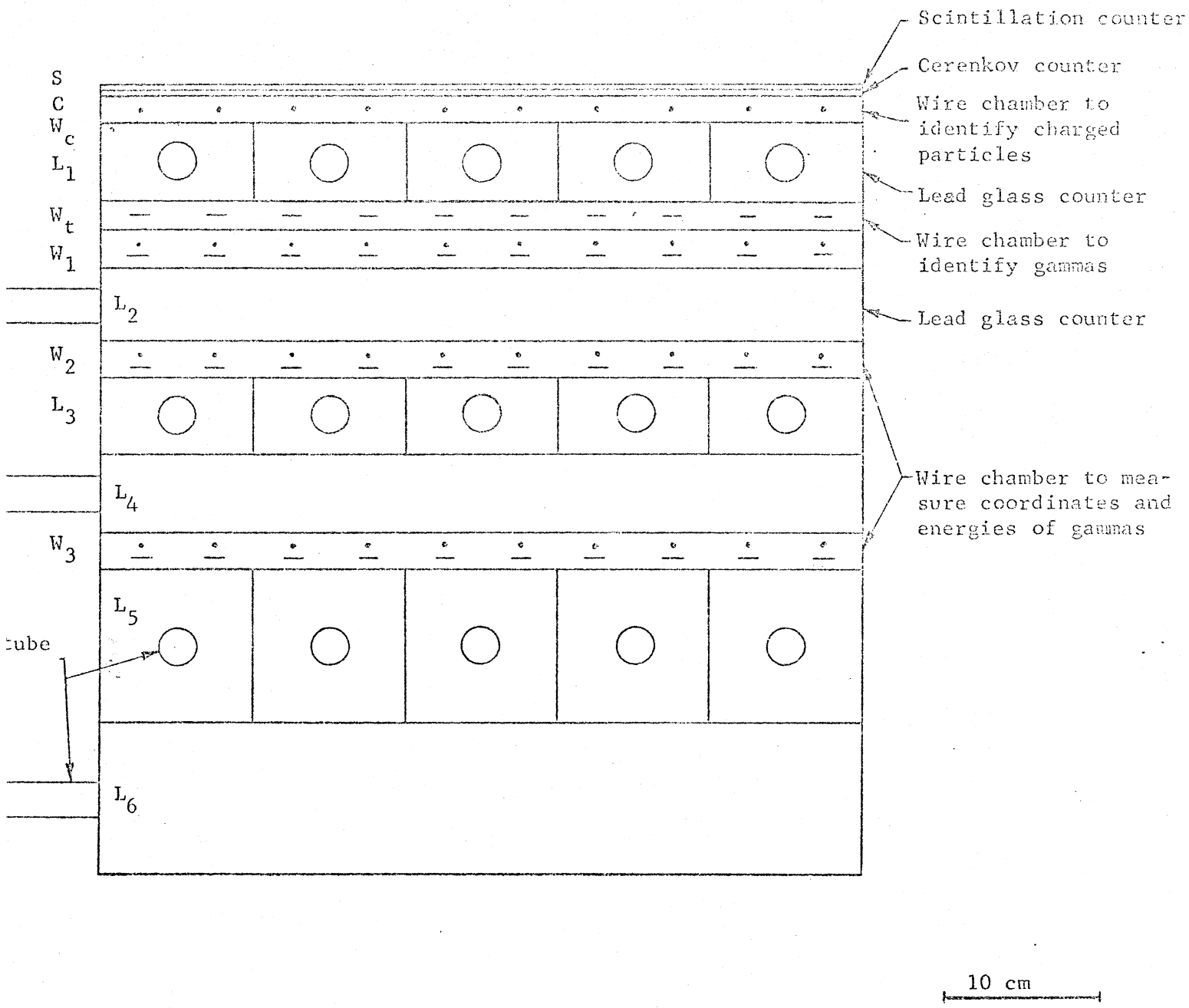

Fig. 3 Details of the detector unit.



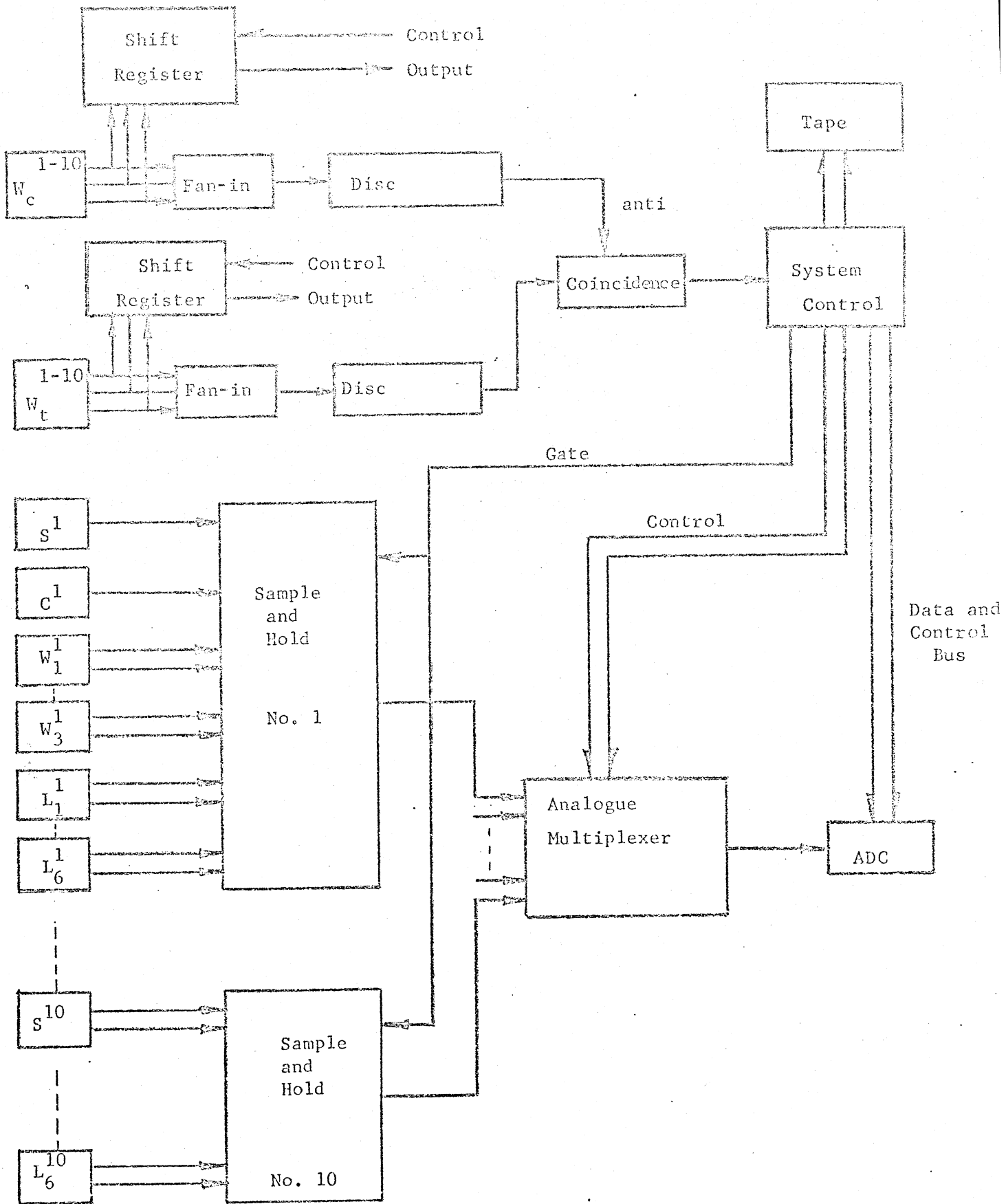
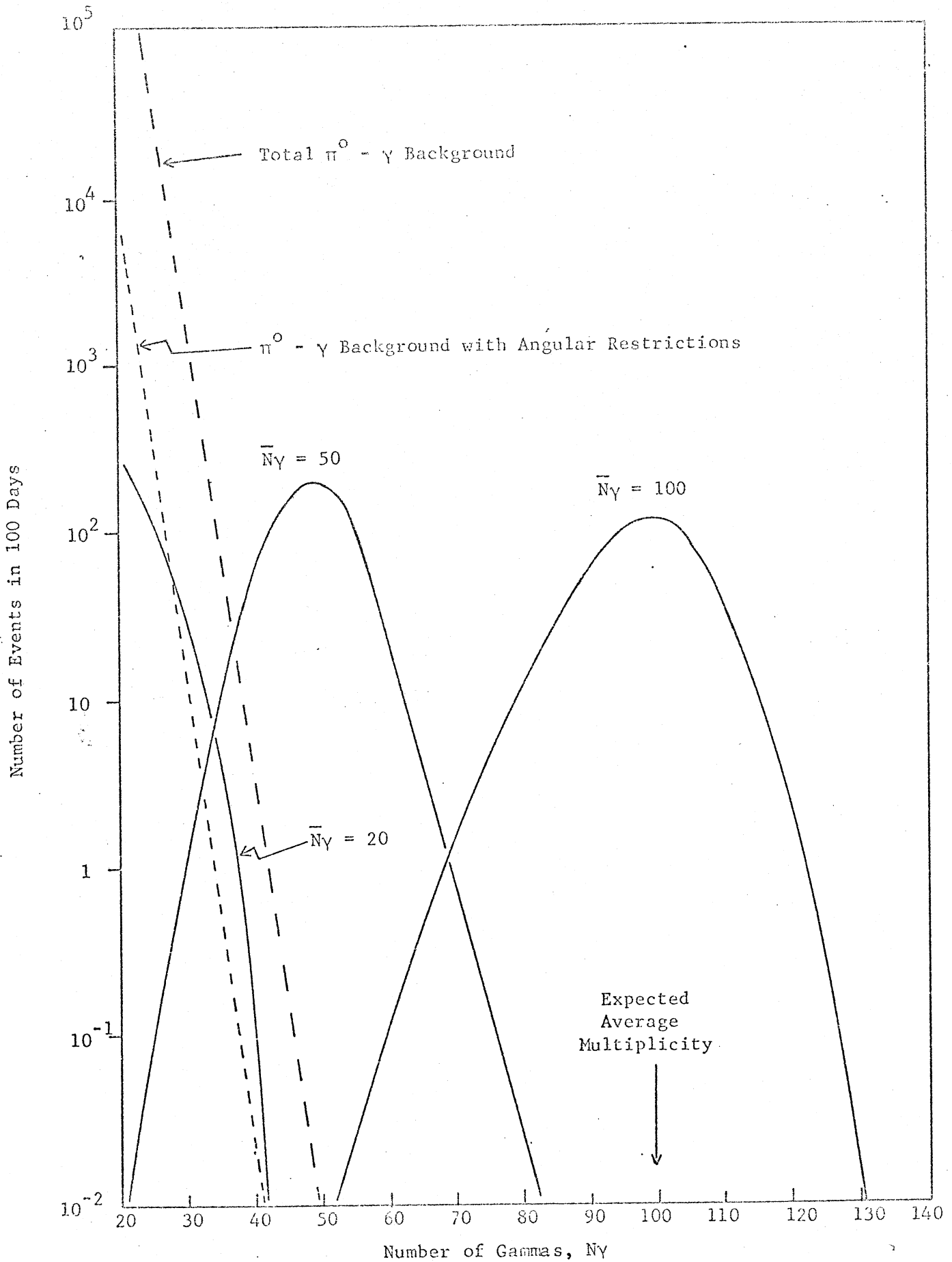

Fig. 4 Electronics Block Diagram.

Fig. 5. Distribution of Multiplicity  $\sigma_{\pi^0} = 10^{-34} \text{ cm}^2$ ,  $P(N\gamma) = \text{Poisson Distribution}$ .



A FEW CONSIDERATIONS CONCERNING THE SEARCH FOR MULTIGAMMA RAY  
EVENTS PRODUCED IN PROTON-PROTON COLLISIONS

Luke C. L. Yuan, G. F. Dell, H. Uto, and C. L. Wang  
Brookhaven National Laboratory  
Upton, New York

John P. Dooher  
Grumman Aerospace Corporation  
Bethpage, New York

E. Amaldi, M. Beneventano, B. Borgia, and P. Pistilli  
Istituto di Fisica "Guglielmo Marconi"  
Universita degli Studi - Roma, Italy  
Istituto Nazionale di Fisica Nucleare - Sezione di Roma

1. Introduction

The present report is a preliminary attempt to summarize some of the physical considerations constituting the background of the proposal presented recently to the ISR Committee of CERN<sup>1</sup> for an experiment aiming to a search for events in which a large number of gamma rays is produced in a single proton-proton collision. Processes of this type can have different origins some of which are discussed below.

The experimental setup quoted above is designed to allow a rather complete study of the gamma rays produced through usual processes (essentially neutral pion decays) in proton-proton collisions at c.m. energies of about 50 GeV: the number and angular distribution of charged particles and gamma rays can be determined for each event, with good angular resolution and high efficiency ( $\eta_c \approx 100\%$ ,  $\eta_\gamma \approx 90\%$ ) over a large solid angle (about 60% of  $4\pi$ ) together with a rough estimate of the energy of each shower generated by the gamma rays detected.

Thus, even if none of the not yet confirmed processes discussed below take place in nature at the ISR energies, the amount of experimental

information that would be collected, especially the  $\pi^0$  production, and  $\pi^0$ ,  $\pi^c$  correlation data would constitute a reasonable return for the effort invested in this research.

It is possible, however, that superimposed on this background of normal type, some anomalous multigamma ray events will be observed. These could originate from different processes, three of which are discussed in the following.

The first one, proposed by Ruderman and Zwanziger,<sup>2</sup> consists in the production and subsequent annihilation of pairs of Dirac magnetic poles.<sup>3</sup>

The second consisting in the production and immediate annihilation of a pair of leptons of high Z, was suggested to us by T. D. Lee and the third is the production of heavy particles of high total angular momentum J.

The last process was also suggested to us by T. D. Lee and only later we became aware that it had been previously considered and discussed in more detail by K. Winter.<sup>4</sup>

Sections 2 to 5 refer to various aspects of the first of these three processes, while the second is mentioned, only very briefly, at the end of Section 2. Finally the third process is briefly considered in Section 6 which contains what we knew about it before we learned of Winter's paper.

2. The creation and subsequent annihilation of Dirac magnetic pole-antipole pairs.

This process has been suggested in 1969 by Ruderman and Zwanziger<sup>2</sup> in order to explain a few high energy multigamma ray events observed in photographic emulsions exposed at high altitudes. These events could not be accounted for by conventional electromagnetic showers originating from a single high energy gamma. They rather appear to be pure photon showers characterized by a very energetic narrow cone of some tens of gamma rays without incident or accompanying charged particles. The radial spread of photons in the plate suggests a c.m. velocity corresponding to  $\gamma \gg 10^{13}$ . When transformed back to the c.m. system many of the photon energies are orders of magnitude too low to be produced in the decay of neutral pions. In addition to multiplicity, another peculiar characteristic is, in some cases, that there exists a large gap, comparable to a radiation length, before any gamma ray conversion is seen. If not a remarkable fluctuation, this can be understood only if a narrow photon cone were produced in the emulsions itself.

As pointed out by Ruderman and Zwanziger a possible explanation of these events could be the creation and subsequent annihilation of a pair of Dirac magnetic poles.

The important point, mentioned also by previous authors,<sup>5</sup> but fully used by Ruderman and Zwanziger, is that when a pair of monopoles is produced, they will probably annihilate in about  $10^{-22}$  sec due to the very strong electromagnetic interaction and will leave behind remanent photons.

The Ruderman and Zwanziger reasoning can be summarized as follows:

a. At sufficient large distances and low velocities the interaction between a pole-antipole pair is given by the coulomb law

$$V(r) = \frac{g^2}{r} \quad (2.1)$$

where

$$g \equiv mg_1 = m \left( \frac{1}{2} \frac{\hbar c}{2} e \right) = m \frac{137}{2} e \quad (2.2)$$

is the magnetic charge and  $m$  is an integer which, according to Dirac, can have any value  $\geq 1$ , while, according to Schwinger,<sup>6</sup> should be at least 2, and possibly 4. If one takes  $m = 2$  the coulomb interaction is larger by a factor  $\sim 2 \times 10^4$  than the electron-positron interaction. Vacuum polarization corrections can only alter the potential energy at any distance  $r$ , while the form factor of the poles, together with possible exchange of strongly interacting mesons would modify the potential only for

$$r \leq r_0 = \frac{\hbar}{m c} = 10^{-13} \text{ cm} \quad , \quad (2.3)$$

corresponding to the Compton wavelength of the lightest hadron.

Therefore, in order for the vacuum to be stable against spontaneous production of pole pairs at distances down to  $r \sim r_0$ , the mass  $m_g$  of the poles should satisfy the condition

$$2m_g^2 c^2 - \frac{g^2}{r_0} = 2m_g^2 c^2 - \frac{g^2}{\hbar c} \cdot m_\pi^2 c^2 \geq 0 \quad , \quad (2.4)$$

from which it follows

$$m_g \geq \frac{1}{2c^2} \frac{g^2}{r_0} = \frac{1}{2} \frac{g^2}{\hbar c} m_\pi = \frac{m^2}{4} \frac{137 \times m_\pi}{2} = \frac{m^2}{4} \times 9.6 \text{ GeV} \approx \frac{m^2}{4} 10 \text{ GeV} \quad . \quad (2.5)$$

Because of this very large value of  $m_g$  the Compton wave length of a Dirac pole is smaller than that of the pion by the factor

$$\frac{r_o}{r_g} = \frac{m^2}{4} \frac{137}{2} \quad (2.6)$$

and the classical picture provides a rough but adequate description of the relative motion of the pole-antipole pair at distances  $r \geq r_o$ , while it would completely fail if applied to electron-positron pairs for distances of the order of the classical radius of the electron ( $\sim 2 r_o$ ).

b. In order that the pole-antipole pair can be separated once they have been produced at a distance  $\sim r_o$ , their relative kinetic energy should be greater than

$$\frac{g^2}{r_o} \approx \frac{m^2}{4} \cdot 20 \text{ GeV} \quad , \quad (2.7)$$

even if the emission of radiation is ignored. This means that the kinetic energy of their relative motion should satisfy the inequality

$$\frac{1}{2} \left[ \frac{m_g^2 c^2}{\sqrt{1 - \beta^2}} - m_g^2 c^2 \right] \geq \frac{g^2}{r_o} \quad (2.8a)$$

which can also be written in the form

$$\gamma - 1 \geq \frac{g^2}{r_o m_g^2 c^2} \quad . \quad (2.8b)$$

Therefore, unless  $m_g$  exceeds considerably the lower limit (2.5), the pole and antipole can be separated only if their relative velocity at  $r = r_o$  is relativistic.<sup>7</sup> But the Dirac poles are very strongly coupled to photons

$$\frac{g^2}{\hbar c} = \frac{e^2}{\hbar c} \left( \frac{g}{e} \right)^2 = \frac{m^2}{4} 137 \quad . \quad (2.9)$$

Therefore one can expect (see point c) that in the creation process such a large fraction of the energy available would be radiated, that the residual kinetic energy of the two poles may not be sufficient for their separation.

c. Nobody knows how to calculate the spectrum of the radiated photons or simply the energy they carry away. The following argument shows, however, that a large energy loss should take place by emission of soft photons; and this can be estimated by classical considerations, at least for soft photons belonging to certain spectral regions.

The first assertion is justified by considering the probability that a pole pair is suddenly emitted with velocity  $v \approx c$ , without an energy loss exceeding  $\Delta E$  to any dipole photon. This is given approximately by the expression

$$\exp \left[ - \frac{8}{3\pi} \frac{g^2}{\hbar c} \ln \frac{m_g c^2}{\Delta E} \right] \approx \exp \left[ - \frac{2}{3\pi} m^2 137 \ln \frac{m_g c^2}{\Delta E} \right] \quad (2.10)$$

obtained by replacing  $g$  with  $e$  in a standard expression used for computing radiative corrections.<sup>8</sup> This expression should hold when the energy  $\hbar\omega$  given to any one photon is less than

$$\hbar\omega_0 \approx \frac{\hbar}{\tau} = \frac{\hbar c}{r_0} = \frac{m_g c^2}{\pi} \quad (2.11)$$

where  $\tau = r_0/c$  is the "acceleration time." Taking for  $m_g$  the lowest value (2.5) and for  $\Delta E$  the value (2.11), the probability (2.10) turns out to be negligibly small.

In order to estimate the energy loss by classical arguments Ruderman and Zwanziger distinguish two emission regions:  $r \leq r_0$  and  $r > r_0$ . Such a division at  $r \sim r_0$  is adequate only for soft photons of wavelength not



large with respect to  $r_0$ . For the first emission region ( $r \leq r_0$ ) they use the expression of the energy emitted by extreme relativistic poles as synchrotron radiation in a fraction of turn of radius  $r_0$ :

$$W_1 \sim \frac{g^2}{\hbar c} \frac{m}{m_g} \gamma^4 m_g c^2. \quad (2.12)$$

The justification of this model, not given by the authors, has been clarified to us by Bruno Touschek who notices that the pole pair is most probably created in states of large angular momentum so that, for  $r \leq r_0$  they describe arcs of circle of radius of the order of  $r_0$  (Appendix A). From (2.12) it follows that the fast poles should leave the region  $r < r_0$  with a kinetic energy much smaller than that of the emitted soft photons.

In the second region ( $r > r_0$ ) the coulomb interaction (2.1) will mainly affect the radial velocity of the poles giving rise to a further loss of the following order of magnitude

$$W_2 \sim \frac{2}{3} \frac{g^2}{c^3} \int_{r_0}^{r_{\max}} |\vec{v}|^2 dt \sim \frac{g^2}{c^3} \int_{r_0}^{r_{\max}} \left( \frac{g^2}{r^2} \frac{1}{m_g} \right) \frac{dr}{c} \sim \left( \frac{g^2}{\hbar c} \frac{m}{m_g} \right)^3 m_g c^2. \quad (2.13)$$

The emission of hard photons depends upon the dynamical details of monopole creation. Since these are completely unknown, Ruderman and Zwanziger suggest to use a statistical model in which an equipartition of energy between the monopoles and many hard photons takes place at the very high temperature  $kT \sim m_g c^2$  necessary for relativistic emission.

In conclusion all these considerations suggest that the energy in the c.m. should exceed  $2 m_g c^2$  enormously in order to create a free pole-antipole pair.

For energies  $E_{c.m.}$  larger but not too much larger than  $2 m_g c^2$  it appears very likely that a bound pair of monopoles be produced in a Keplerian orbit whose

lifetime for subsequent annihilation into photons depends on the time for further radiation to bring them within a distance of less than  $r_0$ .

The maximum distance to which the pole-antipole will be carried is expected to be of the order of  $10^{-12}$  cm and the duration before returning to  $r \leq r_0$  should be of the order of  $10^{-22}$  -  $10^{-21}$  sec. Finally the number of photons emitted is expected to be very roughly of the order of the coupling constant, i.e. of

$$n_{\text{ph}} \sim m^2 \frac{g_1^2}{\hbar c} = \frac{m^2}{4} 137 \quad . \quad (2.14)$$

This general picture not only provides a very reasonable explanation of the anomalous gamma ray showers observed in cosmic rays, that have been mentioned above, but would also explain why until now no experimental evidence has been found for the existence of isolated Dirac poles, even if they would actually exist.<sup>9,10</sup>

It may finally be pointed out that pairs of bound poles could be produced in virtual states and give rise to multigamma events even below their energy threshold.

A completely different mechanism of production of multigamma rays has been suggested by T. D. Lee, who envisages the creation of pairs of highly charged leptons ( $Z \geq 10$ ). In fact, any charged particle with a very strong electromagnetic coupling would yield such events.

Once multigamma events were observed the question would arise as to whether they are induced by magnetic monopoles or by particles such as leptons of high  $Z$ . The angular distribution and the polarization of the photons could be important factors in answering this question.

3. A few remarks about the ratio of bound to free pole-antipole pair production.

According to the picture suggested by Ruderman and Zwanziger and summarized in the previous section, at c.m. energies greater, but not too much greater than  $2 m_g c^2$ , the pole-antipole pairs should be produced in general in bound states, constituting an ephemeral object X, that, for the sake of brevity, will be called di-polium. The production of the pole-antipole pairs would become the dominating process only at much higher energies.

In view of experiments aiming to observe the production either of di-polium or of free pairs, it would be desirable to dispose even of a very crude estimate of the ratio of di-polium to free pair production at c.m. energies above  $2 m_g c^2$ .

An attempt in this direction has been made by Trefil,<sup>11</sup> who considers the collision of two particles of momenta  $p_1$  and  $p_2$ , in which a certain number of hadrons, of total momentum  $p_3$  and a free pole-antipole pair, with momenta  $q_1$  and  $q_2$ , are produced. The problem is that of relating the amplitude  $A(p_1, p_2, p_3, q_1, q_2)$  of this process, computed neglecting the pole-antipole interaction in the final state, to the amplitude  $C(p_1 p_2 p_3 q_1 q_2 Q)$  of a similar process in which the di-polium is produced with momentum Q.

The computation is made by Trefil under two assumptions: (1) in the first reaction the poles can be treated as free particles (on the energy shell) which are created, travel awhile and then interact, so that one can write

$$C(p_1 p_2 p_3 q_1 q_2 Q) = A(p_1 p_2 p_3 q_1 q_2) B(q_1 q_2 Q) \quad (3.1)$$

where B represents the amplitude which describes the final pole-antipole interaction. (2) The poles move slowly so that the amplitude B can be

calculated nonrelativistically

$$B_n(q_1, q_2, Q) = \langle \Psi(r) \left| \frac{2}{r} \right| e^{i(\vec{q}_1 - \vec{q}_2) \cdot \vec{r}} \rangle, \quad (3.2)$$

where for  $\Psi(r)$  one can take the coulomb wave function

$$\Psi_{n\ell m}(\vec{r}) = a^{-3/2} \frac{2}{n^2} \sqrt{\frac{(n-\ell-1)!}{[(n+\ell)!]^3}} \kappa^\ell e^{-\kappa/2} L_{n-\ell-1}^{2\ell+1}(\kappa) Y_e^m(\hat{r}) \quad (3.3)$$

Here  $L$  is a Laguerre polynomial,

$$a = \frac{2\hbar^2}{m_g^2} \quad (3.4)$$

is the Bohr radius, and

$$\kappa = \frac{2r}{na} \quad (3.5)$$

As pointed out by Trefil this model is very crude for various reasons:

(a) the interaction between the poles of a pair is so strong that to treat them as free in an intermediate state [assumption (1)] is not justified;  
 (b) the lifetimes of the di-polium states are so short, that the use of stationary wave functions is also not justified. To these one can add two more comments; (c) the computation is not relativistic and ignores the coupling to the electromagnetic fields (Lamb shift); and finally (d) the pole-antipole interaction is assumed to be coulombian down to  $r \approx 0$ , while we know that, for  $r \sim r_0$ , the unknown structure of the poles can not be ignored. On this last point we will come back at the end of this section.

With all these reservations in mind one can proceed to compute the ratio  $R_n$  of the probability of producing the di-polium in the quantum

state  $n$  to the probability of producing a free pole-antipole pair

$$R_n = \frac{\int |A|^2 dp_1 dp_2 \dots d(q_1 + q_2) \int |B_n|^2 d^3(\vec{q}_1 - \vec{q}_2)}{\int |A|^2 dp_1 dp_2 \dots d(q_1 + q_2) \int d^3(\vec{q}_1 - \vec{q}_2)} = \frac{\int |B_n|^2 d^3(\vec{q}_1 - \vec{q}_2)}{\frac{4\pi}{3} (\vec{q}_1 - \vec{q}_2)_{\max}^3} \quad (3.6)$$

The calculation of this expression is made by standard procedures and with some computational approximations -- much less important than the physical schematizations -- gives

$$R_n \sim 6\pi \frac{(137)^3}{n(n!)^2} \quad (3.7)$$

From this formula one obtains

$$R_1 = 5 \times 10^7, R_2 = 1 \times 10^7, R_3 = 5 \times 10^5, \dots, R_6 = 2 \times 10^1, \dots$$

so that one is tempted to conclude that the production of di-podium in its lower states is much more likely than that of free pole-antipole pairs.

One has, however, to keep in mind that the use in Eq. (3.2) of the coulomb interaction (2.1) and of the corresponding wave functions (3.3), may be not too incorrect for states only extending mainly in the region  $r > r_0$ : now one has

$$\langle r \rangle_{n\ell} = \frac{a}{2} [3n^2 - \ell(\ell + 1)] \quad (3.8)$$

where  $a$  is the Bohr radius (3.4); which, according to (2.4) and (2.5), can be expressed in the form

$$a = \frac{2\hbar^2}{m_g} \frac{1}{m^2 (137/2)^2 \ell^2} \leq \frac{1}{\frac{m}{4} \frac{137 \times m_\pi}{2}} \frac{1}{m^2 (137/2)^2 e^2} = \frac{2^9}{(137)^2} \frac{1}{m^4} r_0 \quad (3.9)$$

Introducing (3.9) into (3.8) and requiring that

$$\langle r \rangle_{n\ell} \geq r_0$$

one obtains, for  $l \ll n$ ,

$$\frac{2^5}{(137)^2} \frac{3}{m^{.4}} n^2 \geq 1, \quad (3.9)$$

or

$$n \geq n_{\min} = \frac{137}{\sqrt{3 \times 2^{.5}}} m^2 = 14m^2. \quad (3.10)$$

For these values of  $n$ , Eq. (3.7) gives negligible values of  $R_n$ . It would be, however, too hasty to conclude that di-polium is never produced; what can be concluded, from this order of magnitude estimate, is only that for those di-polium states for which the procedure sketched above makes sense, the ratio  $R_n$  is always negligible. For these states the orbit picture is valid with good approximation (correspondence principle) since one has

$$\frac{\sqrt{\langle r^2 \rangle - \langle r \rangle^2}}{\langle r \rangle} = \frac{1}{2n+1} \leq \frac{1}{\sqrt{28m^2+1}} \approx \frac{1}{5.3 \cdot m}. \quad (3.11)$$

The corresponding eigenvalues, in the same crude approximation, are given by

$$-E_n = \left( \frac{g}{\hbar c} \right)^2 \frac{m c^2}{4n^2} \geq \frac{(137)^3}{2^9} m^6 \frac{m c^2}{n^2} \approx 710 \frac{m^6}{n^2} \text{ GeV}. \quad (3.12)$$

For the minimum value of  $n$  defined by (3.10), one obtains

$$E_n \approx - m^2 3.6 \text{ GeV} \quad (3.13)$$

where  $m \geq 1$  according to Dirac,  $m = 2$ , or possibly 4 according to Schwinger.

For the states with  $n < n_{\min}$  the situation is probably in some way similar to that encountered in mesic atoms of high  $Z$ : for  $r \leq r_0$  the unknown structure of the poles plays an essential role. The electromagnetic interaction between the two poles does not follow the coulomb

law, but tends to flatten, possibly reaching a finite value of  $r = 0$ . As a result of this flattening of the potential energy, the wave functions of the states with  $n < n_{\min}$  are pushed towards larger values of  $r$ , so that it is quite possible (but not certain or expected) that the production of di-podium in low lying states takes place with considerable probability.

The only certain conclusion of this section is that, at least for the moment, the best guess of what may happen is still obtained from the classical considerations of Ruderman and Zwanziger which, at least, try to take into account, in a qualitative way, the strong coupling of the poles to the electromagnetic field.

4. - Estimates of upper limits for the production cross section of pairs of poles by a single photon, compatible with present limits on Q.E.D. breakdown.

Under the assumption that the general picture suggested by Ruderman and Zwanziger is basically correct, one can proceed to examine this particular multi-gamma production under various conditions. This has been made by various authors, in particular by N. Cabibbo and M. Testa who have prepared an unpublished "Memo" the content of which is reported in this and in the following section.

This section regards the limits on the amplitude of the production of dipolium ( $\chi$ ) by a single photon which can be obtained from the present experimental limits on Q.E.D. breakdown.

For this scope two sets of experimental data are used: the results obtained at Adone on the production of pairs of muons, and the results of the  $(g_\mu - 2)$  experiment.

Cabibbo and Testa start by considering the process

$$e^+ + e^- \rightarrow \chi + n\gamma \rightarrow N\gamma \quad (4.1)$$

in which a total number  $N$  of photons is emitted,  $n$  of which may be called prompt photons. Such a process could arise from diagrams in which a number  $\ell$  of photons is attached to the  $e^+e^-$  line (Fig. 1). The simplest model for the black boxes is given by the poles loop (Fig. 2).

Not much can be said on this process, except general "theorems":

- 1) There is no interference among diagrams with even and odd  $\ell$  (C-conservation);
- 2) Neglecting diagrams in which real photons come from the  $e^+e^-$  lines, the amplitude of process (4.1) goes to zero if the momentum of any of the outgoing photons vanishes (Appendix B).



This theorem, first suggested to us by C. Feinberg, combined with phase space considerations, indicates that in each multi-gamma event all the photons tend to have the same energy in the c.m.

The total cross section of process (4.1), summed over N, can be expressed as ( $2E = \text{total c.m. } e^+e^- \text{ energy}$ )

$$\sigma_x(4E^2) \equiv \sum_N \sigma_{e^+e^- \rightarrow N\gamma} = \sum_{l=1}^{\infty} \sigma_x^l + \sum_{l_2 > l_1} \sigma_x^{l_1 l_2}, \quad (4.2)$$

where the first term originates from all diagrams with photons attached to the  $e^+e^-$  line (Fig. 1) and  $\sigma_x^{l_1 l_2}$  is the interference term between graphs with  $l_1$  and  $l_2$  photons attached to the  $e^+e^-$  line.

The limit that can be stated from Q.E.D. refers only to  $\sigma_x^1(4E^2)$ : it cannot, in any rigorous or semirigorous way, be related to a limit on  $\sigma_x$  since the interference terms could make  $\sigma_x$  greater or smaller than  $\sigma_x^1$  by an unknown factor. Thus this limit is only indicative.

In order to obtain such a limit one notices that  $\sigma_x^1(4E^2)$  is connected to the absorptive part of the photon self-energy by the relation

$$\text{Im } \pi_x(t) = \frac{t}{4\pi\alpha} \sigma_x^1(t) \quad (4.3)$$

where the subscript X indicates that this is the contribution of the state X to the absorptive part. One can then compute the correction to the photon propagator at momentum transfer t as

$$\frac{1}{t} \rightarrow \frac{1}{t} [1 - \pi_x(t)] \quad (4.4)$$

where

$$\pi_X(t) = \frac{t}{\pi} \int_0^{\infty} ds \frac{\text{Im } \pi_X(s)}{s(s-t)} =$$

$$\frac{t}{4\pi^2 \alpha} \int_0^{\infty} ds \frac{\sigma_X^1(s)}{s-t} = \frac{t}{\Lambda^2} \quad (4.5)$$

and  $\Lambda^{-2}$ , for small  $t$ , can be treated as a constant given by

$$\frac{1}{\Lambda^2} = \frac{1}{4\pi^2 \alpha} \int_0^{\infty} ds \frac{\sigma_X^1(s)}{s} = \frac{1}{2\pi^2 \alpha} \int_0^{\infty} dE \frac{\sigma_X^1(E)}{E} \quad (4.6)$$

From the ensemble of all Adone results Cabibbo assumes tentatively the following limit on  $\Lambda^{-2}t$ :

$$\frac{t_0}{\Lambda^2} < 0.1 \quad \text{where } t_0 = (2 \text{ GeV})^2 \quad (4.7)$$

which correspond to a 20% deviation in the  $e^+e^- \rightarrow \mu^+\mu^-$  cross section.

Since, however, one has

$$\sigma_{\mu^+\mu^-}^+(s) \equiv \sigma_{e^+e^- \rightarrow \mu^+\mu^-}(2E) = \frac{4\pi}{3} \frac{\alpha^2}{4E^2} \quad (4.8)$$

one obtains from (4.5) and 4.7),

$$\frac{t_0}{4\pi^2 \alpha} = \frac{\alpha}{3\pi} [\sigma_{\mu^+\mu^-}^+(2 \text{ GeV})]^{-1}$$

One finally has

$$\frac{\alpha}{3\pi} \int_0^{\infty} \frac{ds}{s} \frac{\sigma_X^1(s)}{\sigma_{\mu^+\mu^-}^+(2 \text{ GeV})} < 0.1$$

or

$$\int_0^{\infty} \frac{ds}{s} \frac{\sigma_x^1(s)}{\sigma_{\mu^+\mu^-}(2\text{GeV})} < \frac{1}{\alpha} \quad (4.9)$$

At this point Cabibbo assumes

$$\frac{\sigma_x^1(E)}{\sigma_{\mu^+\mu^-}(E)} = \begin{cases} \text{constant for } E > E_0 \\ 0 & \text{for } E < E_0 \end{cases} \quad (4.10)$$

which means, according to Eq. (4.8), that both cross sections behave like  $s^{-1}$  for  $s > s_0 (= (2E_0)^2)$ .

The the integral appearing in (4.9) becomes

$$\int \frac{ds}{s} \frac{\sigma_x^1(s)}{\sigma_{\mu^+\mu^-}(2\text{ GeV})} = \int \frac{ds}{s} \frac{\sigma_x^1(s)}{\sigma_{\mu^+\mu^-}(s)} \frac{\sigma_{\mu^+\mu^-}(s)}{\sigma_{\mu^+\mu^-}(2\text{ GeV})}$$

and since

$$\frac{\sigma_{\mu^+\mu^-}(s)}{\sigma_{\mu^+\mu^-}(2\text{ GeV})} \approx \frac{4(\text{GeV})^2}{s_{\text{GeV}}} \quad (4.11)$$

one has

$$4 \frac{\sigma_x^1}{\sigma_{\mu^+\mu^-}} \int_{s_0}^{\infty} \frac{ds}{s^2} = \frac{4}{s_0} \frac{\sigma_x^1}{\sigma_{\mu^+\mu^-}} < 137. \quad (4.12)$$

For example, if one takes  $s_0 = (5\text{ GeV})^2$ , one has

$$K \equiv \frac{\sigma_x^1}{\sigma_{\mu^+\mu^-}} < 137 \times 6 \quad (4.13)$$

This relation can be taken as an upper limit for the ratio of the couplings

$$K = \left( \frac{\gamma' \rightarrow \text{gg}}{\gamma' \rightarrow \mu^+\mu^-} \right)^2 \quad (4.14)$$

where  $\gamma'$  indicates virtual photons.

From Eq. (4.13) one sees that large values of  $\alpha_x^{-1}$  are compatible with present limits of validity of Q.E.D.

A different upper limit for the same constant  $\Lambda^{-2}$  can, in principle, be derived from the accurate results of the  $(g_\mu - 2)$  experiment <sup>12</sup> :

$$\frac{a_{\text{exp}} - a_{\text{th}}}{a_{\text{th}}} = (4.5 \pm 2.7) \times 10^{-4} \quad (4.15)$$

where

$$a = \frac{g_\mu - 2}{2}$$

is the constant appearing in the relation between spin and magnetic moment

$$\vec{\mu} = 2(1 + a) \mu_0 \vec{s}$$

and

$$a_{\text{th}} = \frac{\alpha}{2\pi} \left[ 1 + 0.76578 \frac{\alpha^2}{\pi^2} + 2.55 \frac{\alpha^3}{\pi^3} + \dots \right] = 116563.9 \times 10^{-8}$$

includes corrections from pure quantum electrodynamic up to terms of order  $\alpha^3$  as well as from  $\rho$ ,  $\omega$  and  $\varphi$  via their vacuum polarization insertions in the photon propagator.

The correction  $\delta a_g$  from creation of pairs of poles was first considered by De Tollis <sup>13</sup> under the simplifying assumption that poles can be treated as point particles. In general the deviation  $\delta a$  due to a modification of the photon propagator can be expressed in terms of the parameter  $\Lambda$  defined by Eq. (4.6). According to Feynman <sup>14</sup> one has

$$\delta a = - \frac{2}{3} \frac{m_\mu^2}{\Lambda^2} \frac{\alpha}{2\pi}$$

or

$$\frac{\delta a}{a} = - \frac{2}{3} \frac{m_\mu^2}{\Lambda^2} \quad (4.16)$$

By using the Adone's result (4.7) one obtains an upper limit to the contribution of monopoles (or other objects) to  $\delta a/a$  coming from the modification of the photon propagator:

$$\left(\frac{\delta a}{a}\right)_{u.l.} = -1.7 \times 10^{-4} . \quad (4.17)$$

This is of opposite sign of the observed deviation (4.15) but smaller in absolute value. One should, however, keep in mind that  $(g_{\mu}^{-2})$  is also sensitive to other effects different from the modification of the photon propagator. The contribution discussed above corresponds to the diagram of Fig. 3a, while one of the neglected terms is represented in Fig. 3b.

5. - Estimate of production cross section at the ISR.

One can now proceed to estimate the production cross section of di-polium in proton-proton collisions at the ISR energies. This can be made by two different procedures illustrated in Fig. 4 and 5.

In the process of Fig. 4b the di-polium loop is produced by an intermediate photon out of the energy shell: the estimate of the corresponding cross section is obtained by comparison with the process

$$p + p \rightarrow \mu^+ + \mu^- + \text{hadrons} \quad (5.1)$$

illustrated in Fig. 4a: the blob on the left is the same in both processes, and the ratio of the contributions of their right hand parts is given by the factor (4.13) considered in the discussion of the  $e^+e^-$  production cross section. Thus one has

$$\left( \frac{d\sigma_{pp \rightarrow X+hs}}{dM_x} \right)_{\text{real or virtual}} \approx K \frac{d\sigma_{pp \rightarrow \mu^+ \mu^- +hs}}{dM_{\mu\mu}} \quad (5.2)$$

The simplest way of using this relation consists in adopting for K the value of  $K_0 = 1/\alpha$  suggested by Goto<sup>15</sup> (who interprets the couplings as dissociation probabilities) and multiply it by the experimental value obtained recently by the Columbia-Brookhaven-CERN Group<sup>16</sup> for the process (5.1) and  $-q^2 \geq 16 \text{ (GeV)}^2$ . Thus one obtains

$$\left( \frac{d\sigma_{pp \rightarrow X+hs}}{dM_x} \right)_{\text{real or virtual}} \approx 10^{-34} \text{ cm}^2. \quad (5.3)$$

The same scheme has been worked out in more detail by Cabibbo and Testa, who have made an extrapolation from  $E_{\text{lab.}} = 29 \text{ GeV}$  to the ISR energy ( $E_{\text{lab.}} \approx 1.3 \times 10^{12} \text{ eV}$ ), by using a simplified version of a formula derived by Altarelli, Brandt and Preparata<sup>17</sup>, which fits satisfactorily

the experimental data of Lederman et al.<sup>16</sup> at  $\sim 29$  GeV. The simplified formula derived by Testa is

$$\frac{d\sigma_{pp \rightarrow \mu^+ \mu^- +hs}}{dM_{\mu\mu}} = \frac{1}{6} \frac{10^{-33}}{M_{\mu\mu}^5} s \left(1 + \frac{M_{\mu\mu}^2}{s_0}\right) \left(1 - \frac{M_{\mu\mu}^2}{s}\right)^{\frac{1}{2}} \text{ cm}^2/\text{GeV}. \quad (5.4)$$

Table 1 shows the values of this cross section as a function of  $M_{\mu\mu}$ . According to (5.2) the cross section for di-porium production is obtained by multiplying the figures of this Table by the factor K for which the upper limits (4.13) can be adopted.

The main difference between this estimate and (5.3) is that one assumes  $\frac{d\sigma_{pp \rightarrow \mu^+ \mu^- +hs}}{dM_{\mu\mu}}$  to be independent of s, while Eq. (5.4) contains a factor s which leads to a value of  $\frac{d\sigma_{pp \rightarrow x+hs}}{dM_x}$  about 40 times higher than (5.3).

The second estimate, made also by Cabibbo and Testa, is based on Weizsacker-Williams formula (Fig.5) combined with the assumption that

$$\sigma_{\gamma x} \equiv \sigma_{\gamma+p \rightarrow x+\text{hadrons}} \quad (5.5)$$

has the following crude energy dependence

$$\sigma_{\gamma x}(E) = \begin{cases} \sigma_{\gamma x} = \text{constant} & \text{for } E_{\gamma} > \bar{E} \\ 0 & \text{for } E_{\gamma} < \bar{E} \end{cases} \quad (5.6)$$

where  $\bar{E}$  is an adjustable parameter, representing the threshold for di-porium photoproduction.

By a straightforward computation they obtain

$$\sigma_{pp \rightarrow x+hs} \approx \frac{\alpha}{\pi} \ln \left( \frac{E}{m_p} \right) (1 - \bar{\eta}) \sigma_{\gamma x} \quad \left( \bar{\eta} = \frac{\bar{E}}{E} \right) \quad (5.7)$$

In the ISR one has

$$E = \frac{2E_{\text{beam}}^2}{m_p} \approx 1.3 \times 10^{12} \text{ eV} \quad (E_{\text{beam}} = 25 \text{ GeV}) \quad (5.8)$$

so that

$$\sigma_{pp \rightarrow x+hs} \approx 2 \times 10^{-2} (1 - \bar{\eta}) \sigma_{\gamma x}. \quad (5.9)$$

From the cosmic ray data, Ruderman and Zwanziger estimate the threshold for the

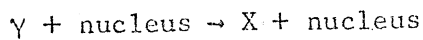

to be  $\bar{E} \approx 10^{13}$  eV.

In their argument the derivation of the threshold originates from the nucleus form factor. If one believes in this argument, one would obtain for the process

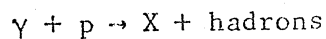

a threshold  $\bar{E} \approx 0.5 \times 10^{12}$  eV which, compared with (5.8) gives  $\bar{\eta} \approx 0.5$ .

Using the Ruderman and Zwanziger estimate for  $\sigma_{\gamma x}$  to be of the order of  $10^{-26} \text{ cm}^2$  (Ref. 18) one obtains the enormous value

$$\sigma_{pp \rightarrow xhs} \sim 10^{-28} \text{ cm}^2 \quad (5.10)$$



Finally, we have tried to estimate the number of events expected at the ISR from Hagedorn thermodynamical model<sup>19</sup> in spite of the doubts that can be raised about its use in the case of di-podium production. After consultation with Hagedorn, who also stressed this point, Dr. Daum from CERN was kind enough to compute the expected event number from this model with the programme set up by him and Andersson<sup>20</sup>. The computed result shows that the number of dipodium produced for interacting proton is not much smaller than that of the antiprotons, as long as the mass  $M_x$  is not too large, but it decreases rapidly as  $M_x$  increases. The numerical results are in general agreement with the simple formula suggested to us by Hagedorn

$$\frac{\sigma_x}{\sigma_p} \approx e^{-\frac{m_p}{T} \left( \frac{M_x}{m_p} - 2 \right)} \approx e^{-6 \left( \frac{M_x}{m_p} - 2 \right)} \approx \left( \frac{1}{100} \right)^{\frac{M_x}{m_p} - 2}. \quad (5.11)$$

#### 6. - Production of heavy particles of large total angular momentum.

As we have mentioned in the introduction, T.D. Lee suggested to us another process that could give rise to burst of gamma rays, which, however, had been already proposed and discussed by K. Winter<sup>4</sup>.

In a high energy proton-proton collision particles could be produced with very high angular momentum  $J$ . Assuming that the square of the mass  $M_J$  of these particles is a linear function of  $J$ , even for large values of  $J$ , and that they decay mainly in steps of  $\Delta J = 1$ , then for sufficiently large values of  $J$ ,

$$\Delta M_J = M_J - M_{J-1}$$

would be smaller than  $m_\pi$ . Consequently the only possible process would be the emission of photons until such a value  $J_L$  is reached that

$$\Delta M_{JL} = m_\pi.$$

From these moment on, the emission of pions would be more likely.

Assuming for the coefficients of the linear relation between  $N_{\pi}^2$  and  $J$  the usual values, one can compute the value of  $J_L$ , which turns out to be about 9. This type of events would be characterized by a number of pions which is roughly independent of the total c.m. energy of the colliding protons, while the number of gammas would increase with the energy by the addition of softer photons. A much more detailed discussion of this possibility can be found in Winter papers.<sup>4</sup>

TABLE 1

Values of the cross section of the reaction  $p + p \rightarrow \text{pions}$  computed by means of Eq. (5.4) at  $s = (50 \text{ GeV})^2$ .

$M_{\text{pion}}$ (GeV)	$\text{cm}^2$	$M_{\text{pion}}$ (GeV)	$\text{cm}^2$
1.0	$4.37 \times 10^{-32}$	11	$0.018 \times 10^{-33}$
		13	$0.010 \times 10^{-33}$
2.0	$1.56 \times 10^{-32}$	15	$0.0064 \times 10^{-33}$
3.0	$2.48 \times 10^{-33}$	17	$0.0043 \times 10^{-33}$
4.0	$0.73 \times 10^{-33}$	20	$0.0025 \times 10^{-33}$
5.0	$0.30 \times 10^{-33}$	22	$0.0018 \times 10^{-33}$
6.0	$0.15 \times 10^{-33}$	25	$0.0012 \times 10^{-33}$
7.0	$0.085 \times 10^{-33}$	30	$0.00063 \times 10^{-33}$
8.0	$0.053 \times 10^{-33}$	35	$0.00035 \times 10^{-33}$
9.0	$0.035 \times 10^{-33}$	40	$0.00020 \times 10^{-33}$
10.0	$0.025 \times 10^{-33}$	45	$0.00010 \times 10^{-33}$

A P P E N D I X - A

Justification of Eq. (2.12)

As it has been clarified to us by Bruno Touschek the use of the synchrotron radiation formula for estimating the energy emitted as soft photons in the region  $r \leq r_0$ , is justified by the fact that the pair of poles is most probably created in states of large angular momentum and since their distance  $r$  is at most  $r_0$  they can be described as moving on arcs of circle, of radius of this order of magnitude, before they start to fly away.

Two types of arguments can be brought in favour of large angular momenta. The first one is that since the c.m. kinetic energy of the two poles is always very large (i.e. relativistic: see point (b) of Section 2), the momentum space available is also very large and the probability that the pair is produced in S states is negligibly small.

On the other hand, because of the strong coupling of poles to photons (2.9), their "effective coupling constant to charges

$$\frac{eg}{\hbar c} = \frac{m}{2}$$

is of the order of 1. This means that the amplitudes corresponding to the exchange of any number of photons between poles and charged particles are of the same order of magnitude. Therefore the pole-antipole pair can pick up angular momenta of any value.

The energy emitted by synchrotron radiation in one turn of radius  $R$  is given by the well known expression

$$\frac{2}{3} \frac{e^2 \beta^4 c}{R^2} \gamma^4 \frac{2\pi R}{v} \rightarrow \frac{4\pi}{3} \frac{e^2}{R} \beta^3 \gamma^4$$

Thus, taking  $R = r_0$  and  $\beta = 1$ , one has

$$\frac{4\pi}{3} \frac{g^2}{\hbar c} \frac{m}{m_g} \sqrt{4} m_g c^2$$

which, apart from a numerical factor  $\sim 4$ , is equal to (2.12).

A P P E N D I X - B

Proofs of Theorem 2 of Section 4

The two following proofs have been given by N. Cabibbo.

1 (classical) - The monopoles exist for a finite time and are separated by a finite distance before annihilation. Therefore they cannot radiate photons of wavelength  $\lambda \rightarrow \infty$  (or frequency  $\nu \rightarrow 0$ ).

2 (quantum mechanical) - The blob with  $\ell + N$  photons (Fig. 6) represents the sum of all connected diagrams with  $\ell + N$  photon lines. The requirement that it should be gauge invariant is satisfied by expressing the blob in terms not of the polarization vectors of the photons  $\epsilon_{\mu}^i$  ( $i = 1, 2, \dots, \ell + N$ ) but of their electromagnetic tensors  $(k_{\mu}^i \epsilon_{\nu}^i - k_{\nu}^i \epsilon_{\mu}^i)$ . This means that the amplitude has a factor  $|k^r| = \omega^r$  for each real photon, and vanishes in the limit  $\omega^r \rightarrow 0$ .

Bibliography

(1) L.C.L. Yuan, G.F. Dell, H. Uto, C.L. Wang, J.P. Docher, E. Amaldi, M. Beneventano, B. Borgia, F. Pistilli: CERN/ISRC/70-19, March 1971.

(2) M.A. Ruderman and D. Zwanziger: Phys.Rev. Lett. 22, 146 (1969).

(3) P.A.M. Dirac: Proc. Roy. Soc. (London), Sec. A 133 69 (1931); Phys. Rev. 74, 817 (1948).

(4) K. Winter: Phys. Letters, (1970)  
see also: G. Neuhofer, F. Niebergall, M. Regler, W.Schmidt-Parzefall, K. Schubert and K. Winter: CERN/ISRC/70-18, 29 September 1970.

(5) For example: E. Teller, quoted by G. Wentzel: Suppl. Progr. Theor. Phys.: No 37-38, 163 (1966).

(6) J. Schwinger: Phys. Rev. 144, 1087 (1966); 151, 1022 (1966); 173, 1536 (1968); Science 165, 757 (1969).

(7) In the non relativistic approximation the inequality (2.8) reduces to that given by R & Z

$$\left(\frac{v}{c}\right)^2 \geq 4 \frac{g}{\hbar c} \frac{m}{m_g}$$

(8) See for example: L.W. Mo and Y.S. Tsai: Rev. Mod. Phys. 41, 205, (1969). The factor  $8\pi/3$  appearing in the exponent of Eq. (2.10) is due to the use of nonrelativistic approximations. In extreme relativistic approximation this factor should be replaced by  $(4/\pi) \ln \gamma$ .

(9) For a systematic review of experimental searches of Dirac poles up to 1968, see: E. Amaldi "On the Dirac Magnetic Poles" in "Old and New Problems in Elementary Particles", Edited by G. Puppi (Academic Press, New York, 1968) page 20. For more recent researches see reference (10).

(10) R.L. Fleischer, H.R. Hart, I.S. Jacobs, P.B. Price, W.M. Schwarz and F. Aumento: Phys. Rev. 184, 1393 (1969). R.L. Fleischer, P.B. Price and R.T. Woods: Phys. Rev. 184, 1398 (1969).  
L.W. Alvarez, P.H. Eberhard, R.R. Ross and R.D. Watt: Science (1969).  
I.I. Gurevich, S.Kh. Khakimov, V.P. Martemianov, A.P. Mishakova, V.V. Ogurtzov, V.G. Tarasenkov, L.M. Barkov and N.M. Tarakanov, Kurchatov Institute of Atomic Energy, Report No.1914 (1969).  
M.I. Blagov, A.I. Isakov, V.A. Murashova, V.A. Petukhov, A.V. Samoylov, T.I. Syreyshchikova, Yu.Ya. Telnov, A.M. Frobov, Yu.D. Usachev, M.N. Yakimenko: Lebedev Institute Report, No. 46 (1970).  
Yu.D. Usachev: Lebedev Institute Report No. 111 (1970).

- (11) J.S. Trefil: Report of the NAL Summer Study: SS-167 Draft 7-17-70, 2026; July 17, 1970.
- (12) J. Bailey and E. Picasso: Progr. Nucl. Phys. 12, 43 (1970).
- (13) E. Amaldi, G. Baroni, H. Bradner, H.G. De Carvalho, L. Hoffmann, A. Manfredini and G. Vanderhage: CERN Report 63-13, Nuclear Physics Division, 10 April 1963.
- (14) R.P. Feynman: La Theorie quantique des champs; XII<sup>me</sup> Conseil de Physique Solvay, 9-14 Octobre 1961, pag. 61.
- (15) E. Goto, H.H. Kolm and K.W. Ford: Phys. Rev. 132, 387 (1963).
- (16) J.H. Christenson, G.S. Hicks, L.M. Lederman, P.J. Limon, B.G. Pope and E. Zavattini: Phys. Rev. Lett. 25, 1523 (1970).
- (17) G. Altarelli, R.A. Brandt and G. Preparata: Phys. Rev. Lett. 26, 42 (1971).
- (18)  $\sigma_{\gamma\kappa} = \sigma_{\text{pair production}} \approx \alpha r_0^2 \times \log \text{ factor} \approx \frac{r_0^2}{10} \approx 10^{-26} \text{ cm}^2$
- (19) H. Grote, R. Hagedorn and J. Ranft: Particle Spectra: CERN 1970.
- (20) S. Andersson and C. Daum: "ISRPRO, A Programme for calculation of particles' production spectra for the ISR with thermodynamical model", CERN, March 1969; "The production of stable particles", ISR Users Meeting, CERN Geneva 10-11 June 1969.



Figures Captions

- Fig.1 - Production of multiphoton events in  $e^+e^-$  collisions; the shaded blobs indicate the monopole contribution to the photon-photon amplitudes.
- Fig.2 - The simplest model of the shaded blob of Fig.1; a single monopole loop.
- Fig.3 - Contributions to the magnetic moment of the muon due to pairs of poles.
- Fig.4 - Process considered for evaluating the production cross section of bound poles pairs in proton-proton collisions by means of Eq.(5.2).
- Fig.5 - Production of bound poles pairs by one of the virtual photons accompanying one of the colliding proton (Weizsacker-Williams method).
- Fig.6 - The shaded blob represents the sum of all connected diagrams with  $L + N$  photon lines: see Fig.1.

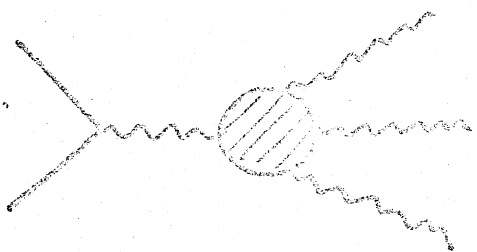

$l=1$

$N=3$

(a)

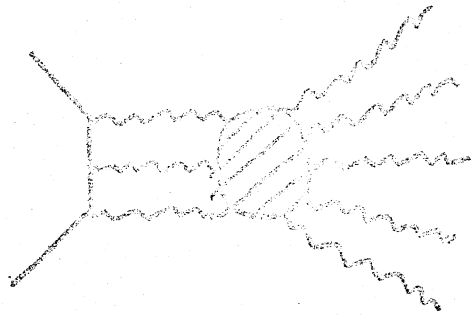

$l=3$

$N=5$

(b)

Fig. 1

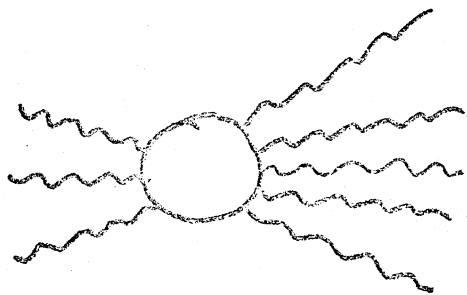

$l$   
(incoming)

$N$   
(outgoing)

Fig. 2

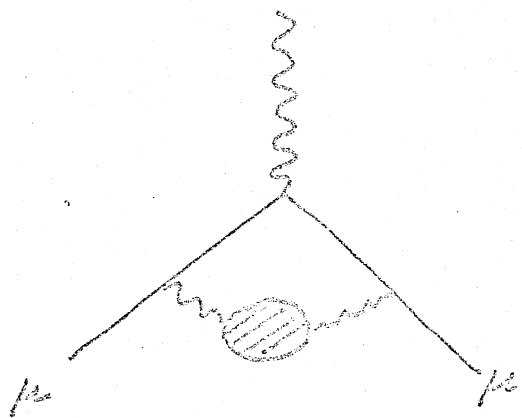

(a)

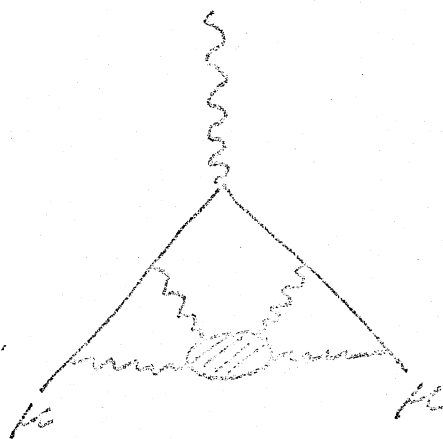

(b)

Fig 3

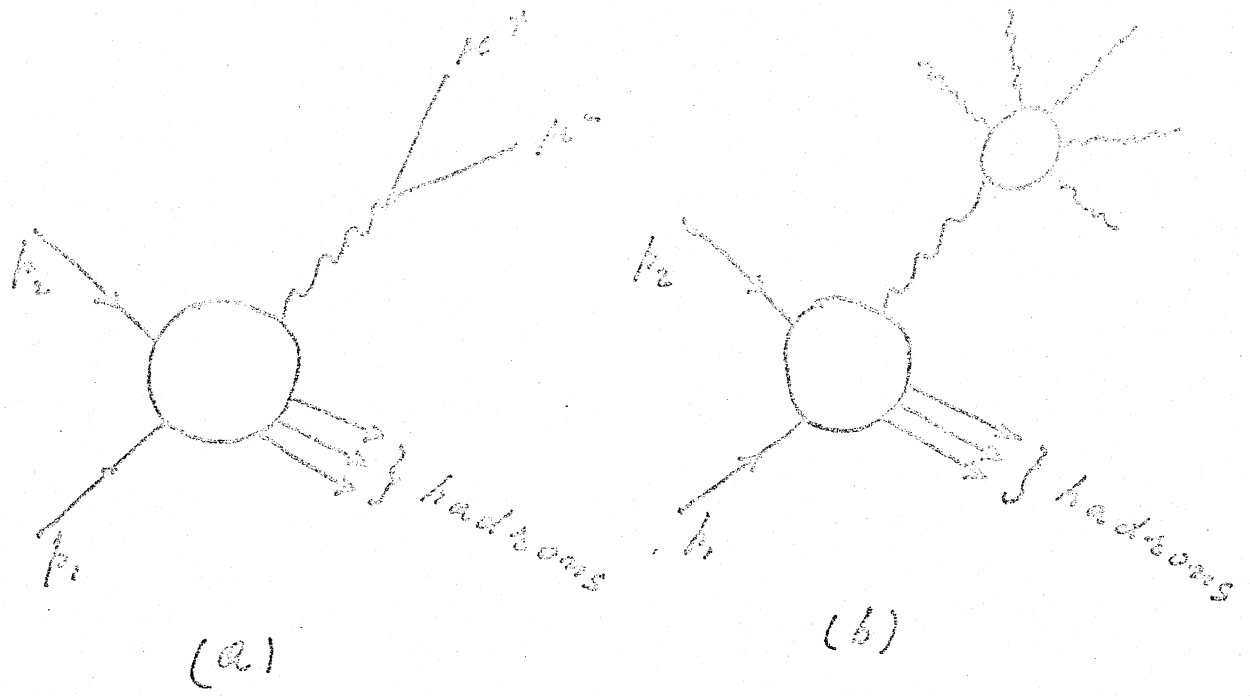

Fig 4

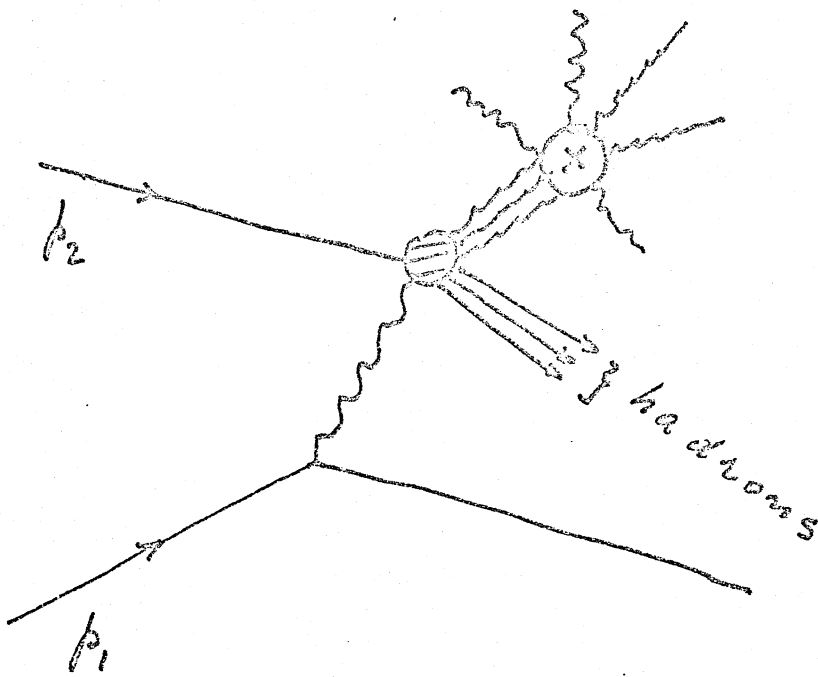

Fig 5

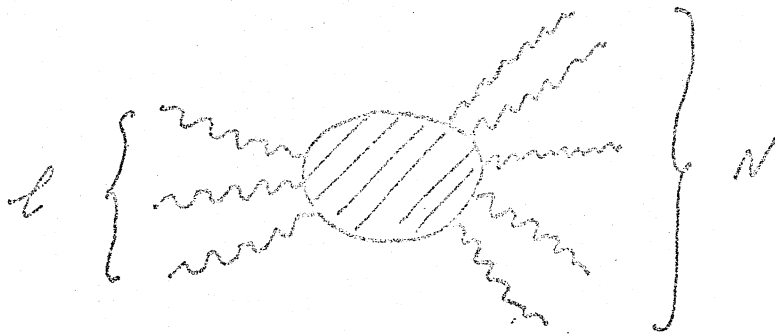

Fig 6