

An RPC-Based Technical Trigger for the CMS Experiment

M. Abbrescia^a, A. Colaleo^a, R. Guida^a, G. Iaselli^a, R. Liuzzi^a, F. Loddo^a, M. Maggi^a, B. Marangelli^a, S. Natali^a, S. Nuzzo^a, G. Pugliese^a, A. Ranieri^a, F. Romano^a, R. Trentadue^a, N. Cavallo^b, F. Fabozzi^b, P. Paolucci^c, D. Piccolo^c, C. Sciacca^c, G. Belli^d, C. De Vecchi^d, A. Grelli^d, M. Necchi^d, S. P. Ratti^d, C. Riccardi^d, P. Torre^d, P. Vitulo^d, T. Anguelov^e, V. Genchev^e, B. Panev^e, S. Piperov^e, G. Sultanov^e, A. Dimitrov^f, L. Litov^f, B. Pavlov^f, P. Petkov^f, K. Bunkowski^g, K. Kierzkowski^g, J. Krolikowski^g, M. Kudla^g, K. Pozniak^h, G. Wrochnaⁱ, A. Korpela^l, M. Iskanius^l, T. Tuuva^l, G. Polese^{l,m}, I. Segoni^m, L. Benussiⁿ, M. Bertaniⁿ, S. Biancoⁿ, M. A. Caponero^o, D. Colonna^p, D. Donisi^o, F. L. Fabbriⁿ, F. Felli^p, M. Giardoniⁿ, M. Pallottaⁿ, A. Paolozzi^p, L. Passamontiⁿ, C. Pucci^p and G. Saviano^p

^aDipartimento Interateneo di Fisica and Sezione INFN, Bari, Italy, ^bUniversità degli Studi della Basilicata and Sezione INFN, Napoli, Italy, ^cDipartimento di Fisica and Sezione INFN, Napoli, Italy, ^dDipartimento di Fisica Nucleare e Teorica and Sezione INFN, Pavia, Italy, ^eINRNE, BAS, Sofia, Bulgaria, ^fUniversity of Sofia St. Kliment Ohridski, Bulgaria, ^gInstitute of Experimental Physics, Warsaw University, Poland, ^hInstitute of Electronic System, Warsaw University of Technology, Poland, ⁱSoltan Institute for Nuclear Studies, Warsaw, Poland, ^lLappeenranta University of Technology, Finland, ^mCERN, Geneva, Switzerland, ⁿLaboratori Nazionali di Frascati dell'INFN, ^oLaboratori Nazionali di Frascati dell'INFN and ENEA Frascati, ^pLaboratori Nazionali di Frascati dell'INFN and Università di Roma I

flavio.loddo@ba.infn.it

Abstract

In the CMS experiment, sub-detectors may send special trigger signals, called “Technical Triggers”, for purposes like test and calibration. The Resistive Plate Chambers are part of the Muon Trigger System of the experiment, but might also produce a cosmic muon trigger to be used during the commissioning of the detectors, the CMS Magnet Test-Cosmic Challenge and the later running of CMS. The proposed implementation is based on the development of a new board, the *RPC Balcony Collector* (RBC); the test results on prototypes and their performance during the recent CMS Cosmic Challenge are presented.

I. INTRODUCTION

The Resistive Plate Chambers (RPC) are gaseous parallel plate detectors that will be used in the CMS experiment for the muon trigger system [1]. The task of the RPC muon trigger is to identify muons, measure their transverse momentum, determine the bunch crossing from which they originate and select the best track candidates. In the CMS Barrel, a total of six layers of RPCs will be embedded in the iron yoke while in the Forward region up to four layers of RPCs will be instrumented, to cover the region up to $\eta = 2.1$.

The block diagram of the RPC Trigger electronics full chain is shown in Figure 1. The signals induced on the readout strips are amplified and discriminated by the Front End Boards [2] and sent unsynchronized to the Link Boards, placed on the detector periphery. The Link Boards synchronize the signals with the 40 MHz LHC clock and, after a data compression (LMUX), send them to the Splitter Boards and then to the Trigger Boards located in the CMS Counting Room over 90 m optical link at 1.6 GHz. Each TB receives signals from up to 6 layers of RPC and implements

the trigger algorithm based on pattern recognition, performed by FPGA devices called Pattern Comparator (PAC). After some steps of sorting and ghost-busting, the RPC Trigger system provides the 8 highest momentum muon candidates to the Global Muon Trigger [3].

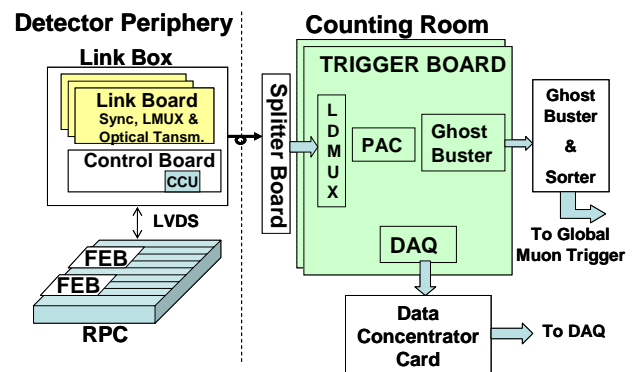

Figure 1: RPC Trigger Electronics Full Chain

II. THE RPC-BASED TECHNICAL TRIGGER

A. Requirements

During the phase of commissioning, the installed RPCs are carefully tested in all their components: gas system, HV, LV and Front End electronics. A crucial aspect for the analysis of the proper functioning of the detection chain is the generation of a trigger signal independent from other detectors and designed to select cosmic muons. Moreover, the CMS experiment itself foresees the possibility that sub-detectors could send special triggers, called Technical Triggers, for test, calibration and other purposes. An RPC-

based cosmic trigger can be designed to cover all these aspects.

The simplest way to implement an RPC-based cosmic trigger is apparently to use the RPC Trigger System itself, just loading the cosmic patterns into the Pattern Comparators. But the RPC Trigger System was built to identify muon tracks starting from the interaction point. This means that all the interconnections among Link Boards and Trigger Boards are optimized to fulfil the vertex geometry, which is not adequate to a cosmic trigger. This goal might be achieved adding some Splitter Boards and Trigger Boards, but another useful feature of the cosmic trigger in the proposed architecture is to be redundant, in order to have a powerful debugging tool independent from the Trigger Electronics.

The demand for an RPC-based cosmic trigger raised up when the design of electronics and cabling in the experimental hall were frozen; therefore, another constraint of this new system is to use, as much as possible, the existing functionalities and infrastructures and don't introduce major modifications to the existing electronics. Then, this technical trigger must be capable to generate a trigger signal both *locally* and *globally*. The local trigger involves the chambers of one Barrel sector and can be used during the Commissioning of the RPCs to check the efficiency of the installed chambers. The global trigger, used as CMS Technical Trigger, involves the whole barrel and requires infrastructures in the counting room.

B. Implementation

In the proposed scheme, the RPC-based Technical Trigger is implemented by two types of electronic boards: the *RPC Balcony Collector* (RBC) housed in the cavern and the *Technical Trigger Unit* (TTU) located in the Counting Room, as shown in Figure 2.

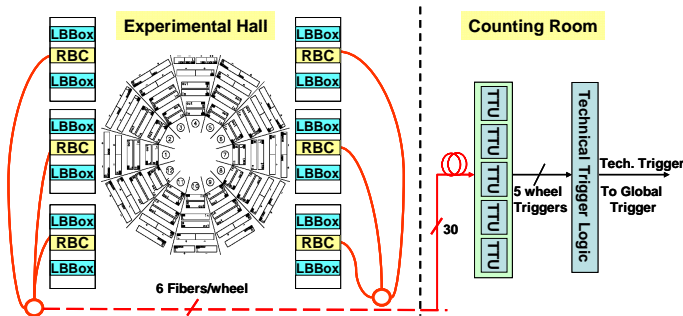

Figure 2: Technical Trigger principles of operation

As described in the previous paragraph, the RPC signal cables are connected to the Link Boards (LB) for synchronization, data compression and optical conversion. Each LB reads 96 strips of one η partition (1 roll = half RPC) and produces an OR signal that can be used for our goal. On the front panel of the LBs there is the *CSC connector*, used only in the forward RPCs to send some synchronization signals from the RPCs to the Cathode Strip Chambers. This connector is not used in the barrel and represents the easiest way to send signals from LBs to RBC without modifying the layout of LBs, already frozen and under production. So, considering also that the cosmic rate at the forward region is

expected to be very low and not adequate to perform quick calibration runs, it was finally decided that the RPC Technical Trigger should involve only the barrel chambers.

The 13 or 15 Link Boards corresponding to the chambers of the same barrel sector are housed in the same crate, called LBBBox (LBB). The LBBs are housed, in groups of 2, in the 30 racks around the detector. In order to keep the overall cost low, it was decided that one RBC should serve two sectors, for a total of 30 RBCs to equip the whole barrel. The most convenient position for the RBC is inside one of the two LBBs of each rack: in fact from the LBB backplane the RBC can receive the power supplies and the slow control signals provided by the Control Boards, while the input ORs can be easily collected from the CSC Connectors of the LBs by means of simple front-planes circuits. In order to improve the manageability of these front-planes, they are divided into two parts, as shown in Figure 3: the FP1 collects the 7 or 9 ORs from the left part of the crate while the FP2 collects the 6 ORs from the right part, beyond the LHC clock and the reconfiguration signal RCO (this last described in the next paragraph) from the LB housed in the slot # 14. The connection between FP1 and FP2 is made by means of a short flat cable. The same Front-Planes will be used also in the LBB non hosting the RBC: in this case, instead of RBC, a special connector called RBC_FAKE will collect and reroute in the proper way the signals to be sent to the RBC of the same rack by means of a shielded twisted pair cable.

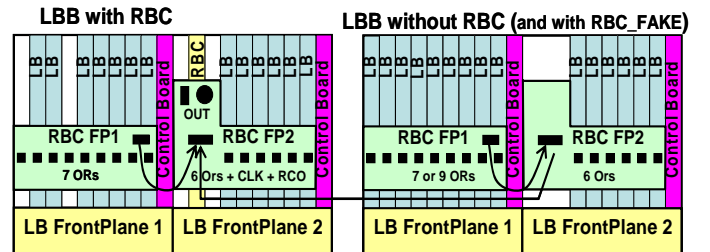

Figure 3: RBC integration in LBBboxes

So each RBC collects 26 or 28 ORs from two sectors, produces two independent sector-based cosmic trigger as "local" triggers and transmit optically the ORs to the Technical Trigger Unit boards in the Counting Room, where a wheel-level cosmic trigger will be produced and sent as technical trigger to the Global Trigger of the experiment.

III. THE RBC BOARD

As shown in Figure 4, the main features of RBC are:

- mask the dead or noisy input ORs;
- produce a sector-level cosmic trigger based on pattern recognition, using pre-loaded pattern and according to selectable majority level;
- force one or more input ORs to be in the pattern, in order to increase the trigger selectivity;
- transmit electrically the OR on the front panel, for eventual data acquisition during the Commissioning;
- introduce selectable latency, at steps of 25 ns, to synchronize the RBC trigger with other detectors;

- remotely controlled using I²C bus;
- transmit optically the ORs to the Counting room.

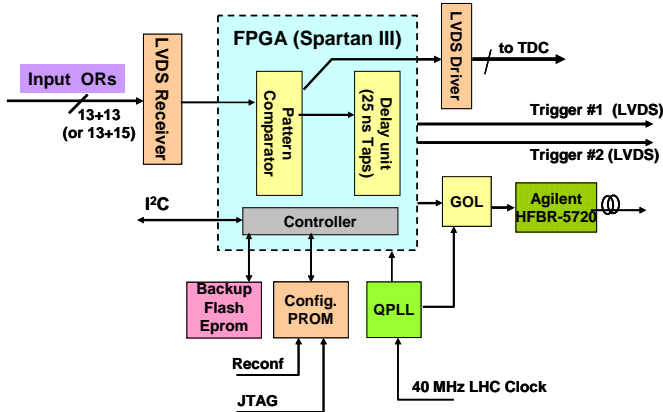

Figure 4: RBC Block Diagram

The RBC has been designed using the Xilinx Spartan-3 FPGA, in order to have high flexibility and the possibility to upgrade the firmware. Since the RBC is out of the slow control CCU chain, the FPGA can be configured only in situ using the JTAG Bus. Therefore, eventual firmware upgrades will be done only during the opening phases of the detector. In any case, this aspect does not represent a major limitation since all RBC parameters can be modified remotely using the I²C bus and moreover, during the experiment, all the signals will be available in the Counting Room, where the TTU board will have a higher flexibility and possibility to be upgraded also remotely.

A. RBC Prototypes

Three prototypes have been produced and successfully tested. The circuit is a 10 layer 14x14 cm² PCB, to be housed on a mother board fitting the LBBBox dimensions. All the I/O are accessible on the front-plane FP2 through a ZPACK connector, with the exception of the power supplies and the I²C bus that are received from the backplane. A picture of the board is shown in Figure 5. The prototypes have been tested both on the Bari test bench and in the Bld. 904 at CERN, where they have been installed in the LBBs (Figure 6) and all the interconnections were checked.

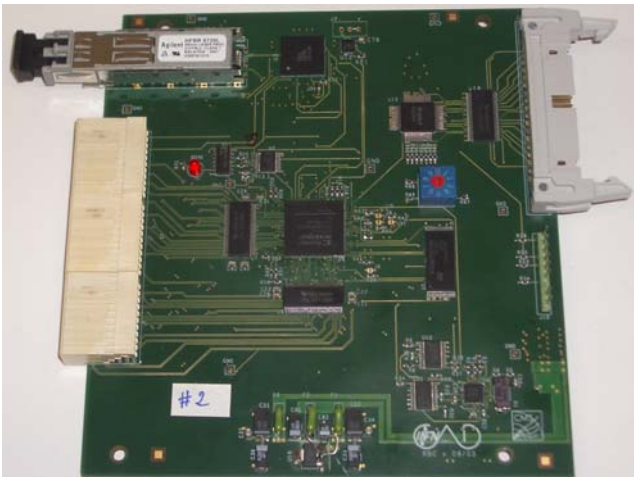

Figure 5: RBC Prototype

Moreover, since during the MTCC the RBC will be located 120 m far from the receiver end (the Local Trigger Controller LTC or the PSB board of the Global Trigger), the LVDS Trigger signal was sent on a 150 m long cable, to check the quality after such a long distance. The LVDS signals, having a pulse width of 75 ns, showed a jitter of ~ 10 ns, while transmitting them in LVPECL and opto-coupled with the receivers, the jitter decreased down to 5 ns and the signals were properly received by both receiving boards in proper synchronization.

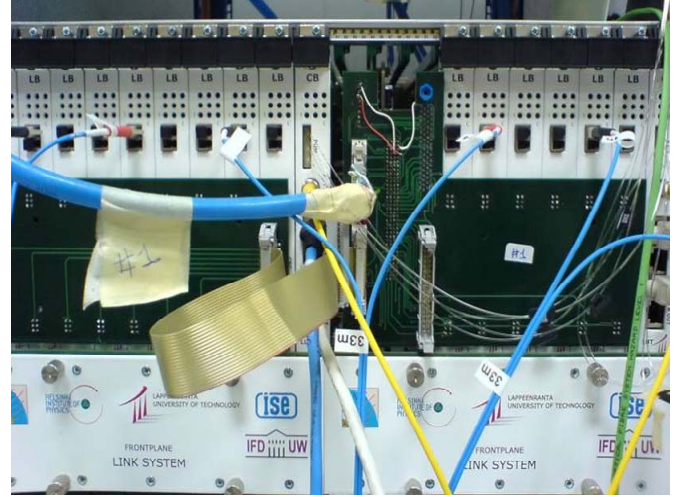

Figure 6: RBC system in LBBBox

B. RBC SEU strategy

On the detector periphery, the environment is not critical. In fact, the expected total dose is less than 1 krad, the neutron flux for neutrons with energy more than 20 MeV is expected to be less than 100 cm⁻²s⁻¹, giving a neutron fluence less than 10¹⁰ cm⁻². The most sensitive device is the SRAM-FPGA, where Single Event Upset might corrupt the configuration memory. Tests performed at Los Alamos Neutron Science Center by Fabula et al. [4] has shown that, for the chosen device, the expected SEU cross section is $\sigma_{\text{bit}} \sim 3.0 \times 10^{-14}$ cm²/bit, corresponding to $\sigma \sim 2.9 \times 10^{-8}$ cm², while the expected Time to Configuration upset = $1/(\sigma \cdot \text{Flux}) \sim 95$ hours/device.

In order to mitigate the risk, since the RBC is embedded into the LB system, it comes natural to adopt the same strategy as the Link Boards (also based on Spartan III FPGAs), that is to reload periodically (every 5 minutes) the configuration SRAM from Flash EPROM, that are extremely robust against our level of irradiation: upon the arrival of the RCO signal from LB, the required time to load the bit stream is about 200 ms.

Concerning the serializer, the rad-tolerant GOL chip developed at CERN is used [5], while the chosen optical transceiver is the AGILENT HFBR-5720L, that was successfully tested by Alice group with neutron fluence 10¹¹n/cm² at different energies: 10 MeV, 150 MeV and 180 MeV [6].

C. MTCC

Two RBC prototypes have been installed and used during the CMS Magnet Test-Cosmic Challenge (MTCC phase I), started in June 2006 to complete the commissioning of the magnet before the lowering in the cavern and, at the same time, to demonstrate the operations of the various sub-detectors with cosmic trigger, the cosmic ray reconstruction across CMS and test the Muon Alignment systems.

Concerning the barrel RPCs, 3 sectors have been involved in the MTCC: the sector 10 of the Wheel YB+1, readout by the RBC1 and the sectors 10 and 11 of the Wheel YB+2, readout by the RBC2, though till the end of September 2006 the sector 11 of YB+2 was not fully equipped with LBs and is expected to be fully operational only for the MTCC phase II, starting at the end of September.

In the MTCC phase I the RBC was connected to a simple L1 trigger system using the LTC as Trigger Controller, while in the MTCC phase II the LTC will be replaced by the Global Trigger and the RBC trigger will be sent to the Pipelined Synchronized Buffer board of GT, that in CMS will be the board receiving the technical triggers.

Beyond the two sector-based RBC triggers (RBC1 and RBC2), the RPC Trigger Board was also used to look for muons pointing to the tracker (RPCT Trigger).

The RBCs were well synchronized with the RPCT Trigger, as well as with the other muon detector (DT and CSC) Triggers.

The RBC Trigger working point has been studied through variations of the RPC High voltage. As an example, the RBC trigger rate as a function of the inner RPC HV of Sect.10-YB+1 is shown in Figure 7.

For both sectors, the trigger rate is about 30 Hz/sector for majority level of 5/6, while working with majority 6/6 the trigger rate is around 13 Hz/sector.

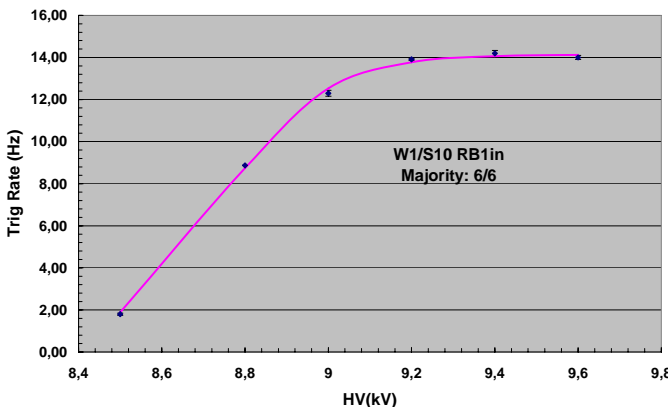

Figure 7: RBC trigger rate vs. inner RPC High Voltage

During the MTCC the RBC has been demonstrated to be a very useful scientific tool to study the performance not only of RPC, but also of DT. In Figure 8, an Iguana event display of a cosmic muon triggered by RBC and crossing RPC and DT is displayed.

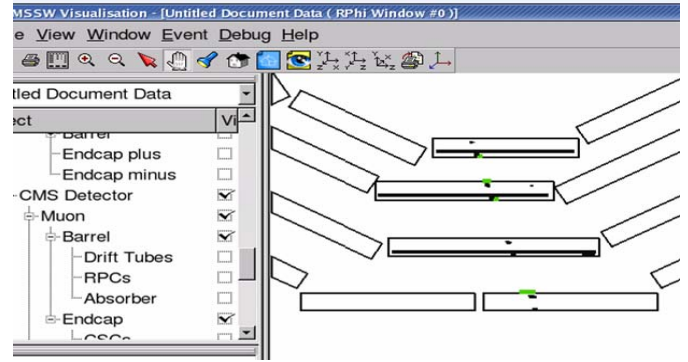

Figure 8: Iguana event display

IV. TECHNICAL TRIGGER UNIT

The Technical Trigger Unit (TTU) boards will be housed in the counting room to receive the produced wheel-based cosmic trigger to be sent to the Global Trigger as Technical Trigger.

The TTU system will receive 30 RBC fibers each carrying 26 or 28 bit at 40 MHz. The signals must be synchronized with the local LHC clock and then the pattern recognition algorithm must be implemented.

All these functionalities are already implemented by the RPC Trigger Board [7] (Figure 9), developed by the Warsaw RPC Trigger Group. In fact, each TB can receive up to 18 fibers and the pattern comparators are implemented into fully programmable FPGAs with large amount of logic cells, enough to implement cosmic pattern recognition based on the OR of strips. Since each of the 6 the Opto-Synch FPGAs can receive at most 72 signals, only 12 links per TB can be used for TTU implementation, hence 3 TBs are needed to equip the full Barrel.

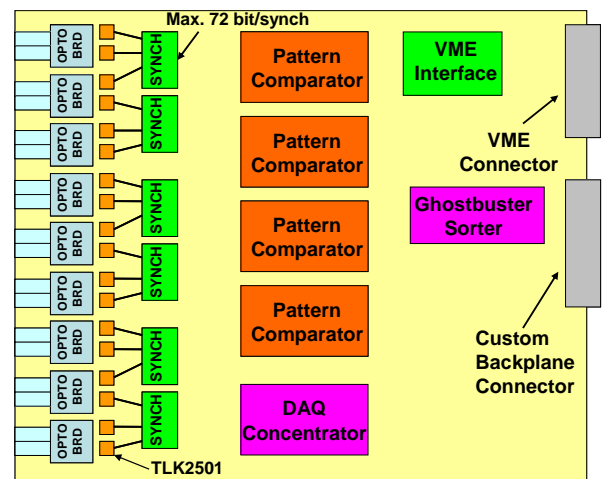

Figure 9: Trigger Board as Technical Trigger Unit

The huge advantage to use TB for this goal is to save time and money to produce new boards and, at the same time, to profit of all other infrastructures needed, such as the hardware and software tools developed by the Warsaw Group to load and control the board remotely. Beyond the development of the new firmware to be uploaded into the PACs, it will be only necessary to design a custom backplane, where mounting the TTC_{rx} chip to receive the timing and

control signals and the simple electronics to properly combine the wheel-level cosmic trigger and produce the final technical trigger.

The TB-TTUs will be placed in the RPC Sorter Crate in the Counting Room.

V. CONCLUSIONS

The architecture of the RPC-based technical Trigger has been shown. A new board, called RPC Balcony Collector, has been designed to produce Sector-Based Cosmic Trigger and the prototypes have been successfully tested and used during the CMS Magnet Test Cosmic Challenge. The RBC will be fully produced before the end of 2006 and in the next weeks the firmware for the TB-TTU and the TTU backplanes will be designed to complete the full chain of RPC-based Technical Trigger.

VI. REFERENCES

- [1] CMS Muon Technical Design Report, 1997
- [2] M.Abbrescia et al., New developments on front-end electronics for the CMS Resistive Plate Chambers, Nucl. Instr. and Meth. A 456 (2000) 143-139

[3] CMS TDR: The Trigger System, CMS Collaboration, CERN-LHCC-2000-038

[4] J.Fabula et al., The NSEU Sensitivity of Static Latch Based FPGAs and Flash Storage CPLDs, MAPLD 2004

[5] P.Moreira et al., A Radiation Tolerant Gigabit Serializer for LHC Data Transmission, Proceedings of the 7th Workshop on Electronics for LHC and Future Experiments, Stockholm, Sweden, 13-17 Sept. 2004, CERN/LHCC/2001-034, 22 October 2001

[6] E.Denes et al., ALICE DDL Radiation Tests for the FPGA Configuration Loss, Proceedings of the 10th Workshop on Electronics for LHC and Future Experiments, Boston, USA, 13-17 Sept. 2004, CERN/LHCC/2004-030.

[7] Z.Jaworski et al., Resistive Plate Chamber (RPC) based muon trigger system for the CMS experiment - pattern comparator ASIC, Nucl. Instr. and Meth. A 419, Issues 2-3 (1998) 701-706