

BEAM CENTERING HEIGHT NOT USED WIDTH HORIZ. HOLD
 Function of Controls

MONOSCOPE CAMERA DENSON ELECTRONICS CORP ROCKVILLE, CONNECTICUT

A couple changes which were recently made for improved pic quality. They are: Grounded pin 6 of the monoscope instead of connecting it to point B on the diagram. Results in improved astigmatism with little sacrifice in gain. Changes the .002 waveshaping condenser (this is the one shown connected from the junction point of the 1K resistor and the .0015 capacitor in the horizontal osc plate circuit) to a .001. Improved the horizontal pulse by changing to this lower value. Changed the 15K which connects the 4700 ohm resistor from the plate circuitry of the vertical discharge tube to pin 7 of V-3B (sync tube) to 8800 ohms. Improved the vertical sync clipping. A little mu-metal shield is needed to prevent beam distortion.

Additional Components Available from DEC

Stock No.	Type	Price
700D	Socket for Vidicon	\$ 3.50
712	New High Resolution Vidicon Direct Drive Deflection Yoke and Focus Coil	59.95
700F	Type 5527 Electrostatic Camera Tube New	50.00
700FA-2	" 1698 - 2 inch Electrostatic Test Monotron SPEC.	9.95
700FA-3	Similar to 1698 except 3 inch NEW (Odd Patterns)	50.00
700H	Type 212 Vericon Camera Tube NEW	100.00
784	Schematic for Type 212 Vericon Camera	5.00
700B	Type 212 Vericon Deflection Yoke NEW	75.00
700A	Type 212 Vericon Deflection Yoke and Focus coil-U	100.00
700J	Type 5820 Orthicon Camera Tube-U	25.00
700L	Type 5820 Orthicon Deflection Yoke - Used	25.00
700LN	Type 5820 Orthicon Deflection Yoke NEW 210D1	100.00
700LF	Type 5820 Orthicon Focus Coil NEW	100.00

page 2



TEST PATTERN

Printed on heavy cardboard
 Postpaid - Small #594 50¢
 Large #595 \$1.00
 Stock #187 at \$5.95-Excellent
 book on CCTV gives very comprehensive course in TV cameras and associated equipment.

FOR CLOSED-CIRCUIT APPLICATIONS VIA MONOSCOPE

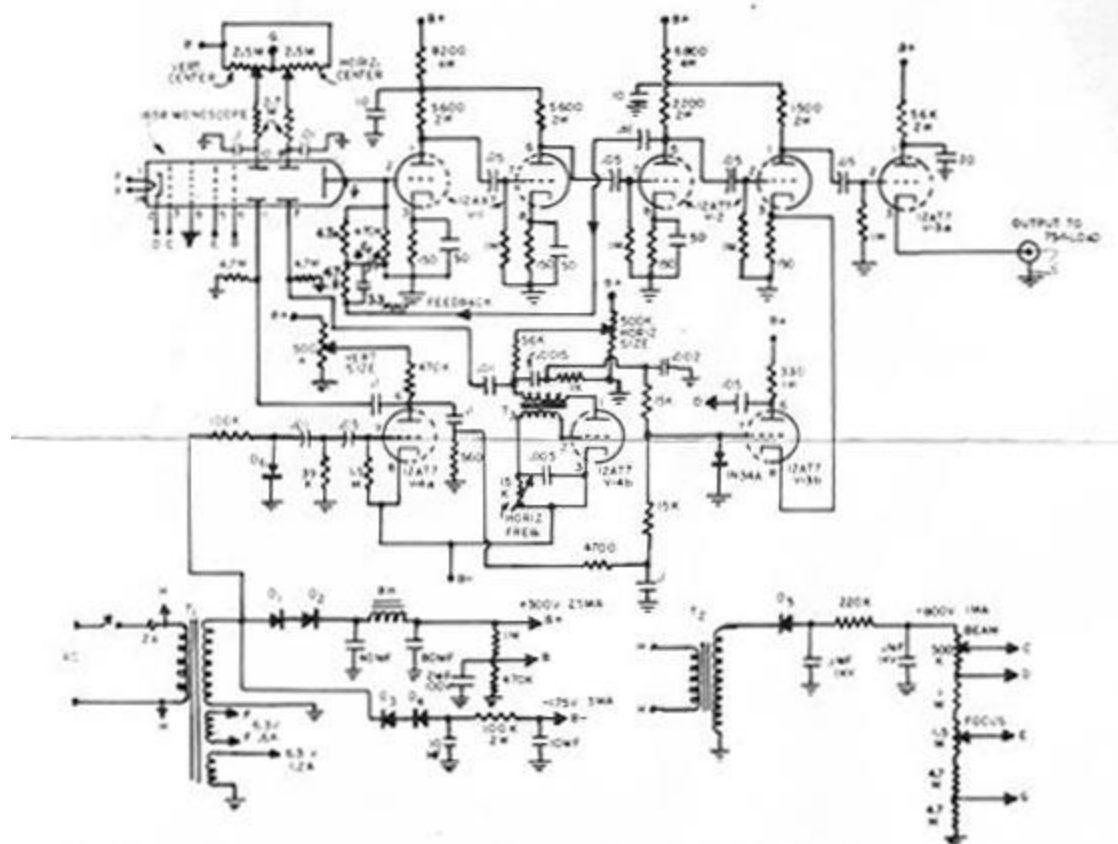

Fig. 1 - Schematic of monoscope camera. *Cf is a 4-40mmfd. compression trimmer. The sizes of the 47K and 3.3mfd (in the feedback loop) can be altered if elimination of smear cannot be obtained within the range of C_f . Variations in individual wiring practices frequently result in such out of range situations. However, careful wiring using standard video amp practices should prevent this.

The entire unit can easily be constructed on an 11 x 17 inch chassis. A photo showing the parts layout in our original unit is shown on the front cover. This arrangement proved to be quite adequate except that we would recommend anyone duplicating it to place the low voltage power transformer more to the left rear, since in the location shown its magnetic field effects the monoscope beam with the mu-metal shield removed. OPERATION: The minute current variations developed across the signal load resistor (470K grid resistor in first amp) are sufficiently amplified by a four stage video amplifier; the first three stages of which incorporate negative feedback to offset the capacity losses from the signal plate and signal lead to ground. The amplified signal is coupled to the 75 ohm line through the cathode follower, V3a. Sync-blanking pulses are mixed with the video in the cathode circuit of V2b. Note that the cathode of the 6AR5 is operated about 800 V above ground. Therefore the filament must also be operated above ground from a separate winding. Vertical sweep is obtained through a discharge stage, V4a locked to the AC line through a waveshaping and clipping network.

Horizontal sweep is obtained from a blocking oscillator, V4b. The combinatoric sync-blanking pulse developed across the resistor in the discharge network of each deflection amp is mixed, clipped and inserted in the fourth video amp by the sync-blanking inserter, V3b. Focusing, beam current adjustment and centering controls are all conventional similar to those used in most scope circuits. The two power supplies are also quite straightforward and should require no explanation... just one thing. It will be noticed that we have +300 and a -minus 175 instead of a single + 475. The reason being, 300 volts was

needed for the video amp and sync inserter but the additional voltage was advantageous for improved sweep linearity. Voltage dropping resistors could have been used but we liked the fact that this allowed us to use readily available lower voltage capacitors both in the power supply and also in the coupling and discharge networks. The method you choose will depend on your own personal preference.

TUNE UP: Assuming no wiring errors or defective components, check out procedure is relatively simple compared to a flying spot or vidicon. Being an electrostatic type tube it's merely a matter of correctly setting the adjustment pots. Proceed in the following manner:

- (1) Set all knobs except the beam (which should be set for max (min) bias) to mid-range.
- (2) Check to make sure monitor is properly adjusted on a local station prior to feeding video to it. (be sure it's properly terminated.)
- (3) Now apply power and allow about 2 minutes for stabilization. The monitor should now be locked vertically since the vertical sweep is derived from the 60 CPS line. The horizontal osc is free running and unless you were lucky will probably not be on frequency. If this is the case, adjust the frequency pot in the camera till the monitor is properly locked.
- (4) You are now ready to see if you can get a pattern. Start advancing the beam control (lowering the grid bias.) An image should immediately become visible. If so, continue bringing up the beam until a normal contrast picture is obtained. Now the centering, focus and size controls can be adjusted for best picture.

GENERAL.

Heater, for unipotential cathode
voltage 6.3 ac or dc
current 0.6 amp.

direct interelectrode capacitances (approx)

Grid No. 1 to all other electrodes. 10 uuf
Signal electrode to all others 2.4 uuf

Focusing method Electrostatic

Deflection " Electrostatic

Target size 1.72 diagonal

Overall Length 8 3/16"

Maximum diameter 2 1/4"

Mounting position any

Cap (ball)recessed small

Base Med. shell

Basing: diheptal 14 pin

Pin. 1 and 14 Heater Pin 9 grid no.2

Pin 2 cathode Pin 10 vert.defl.dj2

Pin 3 grid no. 1 (beam) Pin 11 " " dj1

Pin 4 internal connection, not used Pin 12 internal conn.

Pin 5 grid no. 3 (focus) Pin 13 " "

Pin 6 grid no. 4 Pin 14 heater

Pin 7 Horiz. deflection dj3 Cap.signal electrode

Pin 8 " " dj4

Maximum Ratings,

Signal electrode, grids 1,3, & 4 1000 volts max.

Grid no. 2 500 "

negative bias value 200 volts max.

positive bias value 0 "

heater to cathode (peak) 2 volts max.

heater neg. with respect to cathode 140 "

heater pos. with respect to cathode 10 volts max.

Ambient temperature 100°

Typical operation 800 volts

signal electrode 850 volts

grid no. 4 voltage

grid no. 3 " for focus @ 0.2ua

grid no. 4 current 100 to 210 volts

grid no. 2 voltage 800 volts

grid no. 1 voltage for visual cutoff with external shield 75 volts

grid no. 2 current with 0.2ua current grid no. 4 75ua

Deflection factors

(at Max grid no. 4 voltage)

DJ1 and DJ2 50 to 68 vdc

DJ3 and DJ4 38 to 52 vdc

min. p.p. blanking voltage 30 volts

signal electrode current 0.12ua

Resolution capability 225 min.

Max. circuit values

Grid no. 1 circuit resistance 1.0 megs

resistance in any deflecting electrode circuit 5.0 megs

It is recommended that the deflecting electrode circuit resistance be approx. equal.

TENTATIVE DATA
R.C.A.
TYPE 1698
TWO INCH
MONOSCOPE
ONLY \$7.95

SIMPLER than a flying spot scanner-LESS fussy than a Camera, this pattern generator produces a series of figures and numbers from the self-contained pattern.

DEFLECTION ANGLE FOR THE VERT & HORIZ PLATES IS 20°

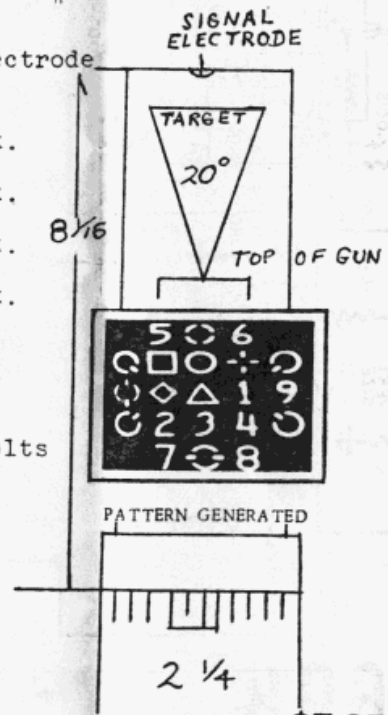

Stock No. 700FA-2 ONLY \$7.95

plus postage - Ship.Wt. 3 lbs.

Instructions Only - 50¢ - Stock No. 779

103

