

## THE PHIN PHOTO-INJECTOR FOR THE CTF3 DRIVE BEAM

R. Losito, H.-H. Braun, N. Champault, E. Chevallay, V. Fedosseev, A. Kumar, A. Masi,  
G. Suberlucq, CERN, Geneva, Switzerland  
M. Divall, G. Hirst, G. Kurdi, W. Martin, I. Musgrave, I. Ross, E. Springate,  
CCLRC/RAL, Chilton, Didcot, UK  
G. Bienvenu, B. Mercier, C. Prevost, R. Roux, LAL IN2P3 - CNRS Université Paris-Sud -  
UMR 8607, Orsay, France

### Abstract

A new photoinjector for the CTF3 drive beam has been designed and is now being constructed by a collaboration among LAL, CCLRC and CERN within PHIN, the second Joint Research Activity of CARE. The photoinjector will provide a train of 2332 pulses at 1.5 GHz with a complex timing structure (sub-trains of 212 pulses spaced from one another by 333 ps or 999 ps) to allow the frequency multiplication scheme, which is one of the features of CLIC, to be tested in CTF3. Each pulse of 2.33 nC will be emitted by a Cs<sub>2</sub>Te photocathode deposited by a co-evaporation process to allow high quantum efficiency in operation (>3% for a minimum of 40 h). The 3 GHz, 2 1/2 cell RF gun has a 2 port coupler to minimize emittance growth due to asymmetric fields, racetrack profile of the irises and two solenoids to keep the emittance at the output below 20  $\pi$ .mm.mrad. The laser has to survive very high average powers both within the pulse train (15 kW) and overall (200 W before pulse slicing). Challenging targets are also for amplitude stability (<0.25% rms) and time jitter from pulse to pulse (<1ps rms). An offline test in a dedicated line is foreseen at CERN in 2007.

Contribution to the EPAC'06, Edinburgh, UK

## THE PHIN PHOTOINJECTOR FOR THE CTF3 DRIVE BEAM

R. Losito, H.-H. Braun, N. Champault, E. Chevallay, V. Fedosseev, A. Kumar, A. Masi,  
G. Suberlucq, CERN, Geneva, Switzerland

M. Divall, G. Hirst, G. Kurdi, W. Martin, I. Musgrave, I. Ross, E. Springate,  
CCLRC/RAL, Chilton, Didcot, UK

G. Bienvenu, B. Mercier, C. Prevost, R. Roux, LAL IN2P3 - CNRS Universite Paris-Sud - UMR  
8607, Orsay, France.

### Abstract

A new photoinjector for the CTF3 drive beam has been designed and is now being constructed by a collaboration among LAL, CCLRC and CERN within PHIN, the second Joint Research Activity of CARE. The photoinjector will provide a train of 2332 pulses at 1.5 GHz with a complex timing structure (sub-trains of 212 pulses spaced from one another by 333 ps or 999 ps) to allow the frequency multiplication scheme, which is one of the features of CLIC, to be tested in CTF3. Each pulse of 2.33 nC will be emitted by a Cs<sub>2</sub>Te photocathode deposited by a co-evaporation process to allow high quantum efficiency in operation (>3% for a minimum of 40 h). The 3 GHz, 2 1/2 cell RF gun has a 2 port coupler to minimize emittance growth due to asymmetric fields, racetrack profile of the irises and two solenoids to keep the emittance at the output below 20  $\pi$ .mm.mrad. The laser has to survive very high average powers both within the pulse train (15 kW) and overall (200 W before pulse slicing). Challenging targets are also for amplitude stability (<0.25% rms) and time jitter from pulse to pulse (<1ps rms). An offline test in a dedicated line is foreseen at CERN in 2007.

### INTRODUCTION

The third CLIC Test Facility (CTF3) will demonstrate the feasibility of the CLIC drive beam generation scheme. In CTF3 the timing structure of a beam of 3.5 Amps average current, stored in a 1.5  $\mu$ sec train of 2332 10 ps long pulses separated by 666 ps (1.5 GHz repetition rate), will be modified in two successive rings. After acceleration in the drive beam linac, half of the pulses will be deviated in the Delay Loop and, after one turn, will interleave with the following pulses. In the successive Combiner Ring, the frequency of the bunches within one train is still multiplied by five interleaving successive sub-trains. At the end of the process the 2332 pulses will be compressed into a 140.7 nsec train with a repetition frequency of the pulses of 15 GHz. In order to have a regular bunch distance in the final train it is necessary to generate the 1.5 GHz laser pulses in subtrains of 212 pulses alternately spaced by 333 ps or 999 ps.

The photoinjector is being built in collaboration among LAL, RAL and CERN, and funded within the second JRA

\*We acknowledge the support of the European Community-Research Infrastructure Activity under the FP6 "Structuring the European Research Area" programme (CARE, contract number RII3-CT-2003-506395)

of CARE, the EU project for a Coordinated Accelerator Research in Europe. LAL is responsible for the design and construction of the RF gun, RAL for the design and construction of the laser and CERN for producing the photocathodes, overall coordination and commissioning. The main parameters of the photoinjector are resumed in tab. 1:

Table 1: Main Parameters of the CTF3 drive beam photoinjector

Parameter	Nominal
Charge/bunch	2.33 nC
Number of bunches	2332
Distance between bunches	667 ps
Average current in the train	3.5 Amps
$\epsilon_T$	< 25 $\pi$ .mm.mrad
UV energy/bunch	0.368 $\mu$ J
IR Energy/bunch	> 10 $\mu$ J
Quantum Efficiency	> 3%
Charge stability	< 0.25% rms
Train repetition rate	1 $\div$ 50 Hz

### PHOTOCATHODES

Following the successful experience in CTF2 with Cs<sub>2</sub>Te films co-evaporated on a copper substrate, a high quantum efficiency (>3%) during operation has been specified. The cathodes will be prepared in the existing photocathodes laboratory at CERN. The deposition chamber allowing the co-evaporation of Cs and Te has been completely refurbished to ensure good performances over the lifetime of CTF3 and to better control the stoichiometric ratio of the deposited compound. In CTF2 in fact over the cathodes produced (>10) a large spread in Quantum Efficiency was observed (min. <3%, max 22%). For this reason we studied the illumination of the cathode from the ovens containing the compounds of Cs and Te, and redesigned the masks used to protect the sensors measuring the amount of each element deposited from the other element. The new mask allows now to measure independently the thickness of each element deposited and therefore to control the stoichiometric ratio. A detailed campaign of calibration of the two sensors is in progress, by correlating the instrument measurements with the thickness measured with different methods. The

production of cathodes for the RF gun test will start at the end of this summer.

## RF GUN

The design of the RF gun is based on a previous 3 GHz CERN RF gun [1] (so called “type IV”).

The new RF gun is optimised for lower single bunch charge but higher total charge modifying the angle of the half-cell wall around the photo-cathode to provide additional transverse focusing in order to maintain the required energy spread at the output.

The shape of the cells is elliptical to decrease the surface electric field minimising the risk of electrical breakdown and dark currents. The cells dimensions have been fine tuned using SUPERFISH to equalize the peak accelerating field in each cell.

RF power is fed to the gun via standard 3 GHz waveguides and coupled to the third cell through two holes symmetric with respect to the beam axis. In addition the coupling cell has been given a racetrack shape to reduce undesired emittance degradation from asymmetry of the transverse fields [2]. The coupler is overcoupled to a factor of three to fully compensate at nominal field the heavy beam loading due to the high average current (3.5 Amps) in the RF pulse.

A thorough study of beam dynamics in the gun has been performed using a modified version of PARMELA [3] that allows the simulation of electron beam propagation in photo-injectors. The simulations showed the necessity to add two solenoids around the gun in order to reduce emittance degradation due to space charge forces. The focusing coil is placed just after the coupling cell and the bucking coil between the photocathode preparation chamber and the gun (see fig. 2).

Results of simulations after optimisation of the RF phase, of the magnetic field and of the laser pulse profiles, show that good performance in terms of emittance is obtained at the expense of a small increase of the energy spread and

bunch length.

Vacuum aspects inside the photo-injector were given a high priority since previous experiments performed at CERN in CTF2 evidenced an exponential growth of vacuum pressure as a function of the total extracted charge, regardless of the bunch-train distribution.

MONTECARLO simulations show that the vacuum pressure in the gun can not be lowered to less than  $2 \cdot 10^{-9}$  mbar in the first half-cell because of the low conductance of the photo-injector. In order to improve the quality of vacuum, a NEG (Non Evaporable Getter) coating will be applied on the vacuum chamber at the output of the gun and on the inner surface of a cylindrical chamber around the gun. The RF Gun's vacuum is connected to the vacuum of this chamber via 42 ducts drilled in the walls of the half-cell and the middle cell of the gun (see fig. 2). The extra pumping coming from the NEG film allows to reduce the residual pressure by a factor of 2, achieving  $10^{-9}$  mbar. In addition, as the pumping velocity is higher, recovery of normal pressure after a sudden out-gassing is expected to be significantly shorter. To further improve the static pressure, a high temperature firing (800 °C) of the photo-injector is foreseen. In this case, simulations predict a residual pressure of  $10^{-11}$  mbar in the 1<sup>st</sup> cell.

A prototype of the RF gun has been built to confirm the RF simulations. The measured resonant frequency was in agreement with the expectations while the balance of electrical field between cells was very poor. The discrepancy between simulation values and prototype measurements comes from a too coarse meshing of the model, due to a limitation in maximum number of nodes for the HFSS version used. Specification values have been recovered by iterative machining of the coupling cell dimensions.

## LASER

The CTF3 laser system, whose layout is shown in fig. 2, shares many of its design principles with the PILOT laser which was developed for CTF2 [4]. A novel feature is the pulse coding system, based on a fibre optic modulator, which generates the subtrains described above.

A commercial Nd:YLF oscillator/preamplifier (High Q Laser Production GmbH) produces a cw train of 6 ps pulses synchronised to the CTF3 timing signal. A time jitter of <100 fs rms has been measured, well below the 1 ps requirement.

The average output power is ~10 W without the coding system. Coding losses will reduce this, but tests in which the oscillator beam was attenuated by a factor of ten only caused the saturated preamplifier output to drop to 6 W.

The repetitive insertion and removal of a 333 ps delay between consecutive laser pulses requires the fastest of optical switches. Pockels cells are fast enough but their kilovolt drive cannot be switched at 7 MHz with the required stability. Fortunately gigahertz fibre modulators driven by just a few volts have been developed by the telecoms industry.

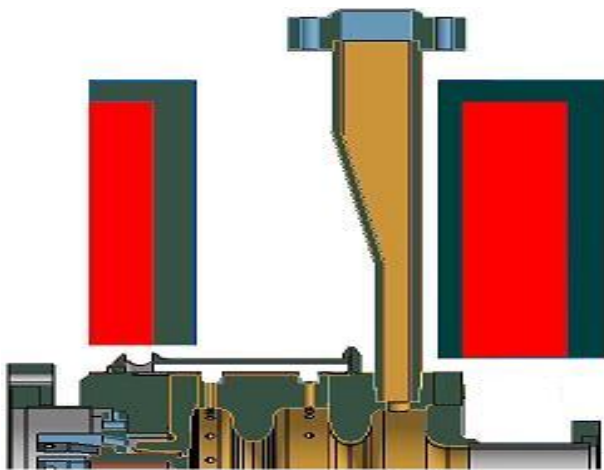

Figure 2: cut in the horizontal plane of the technical drawing of the photo-injector. Red blocks are coils.

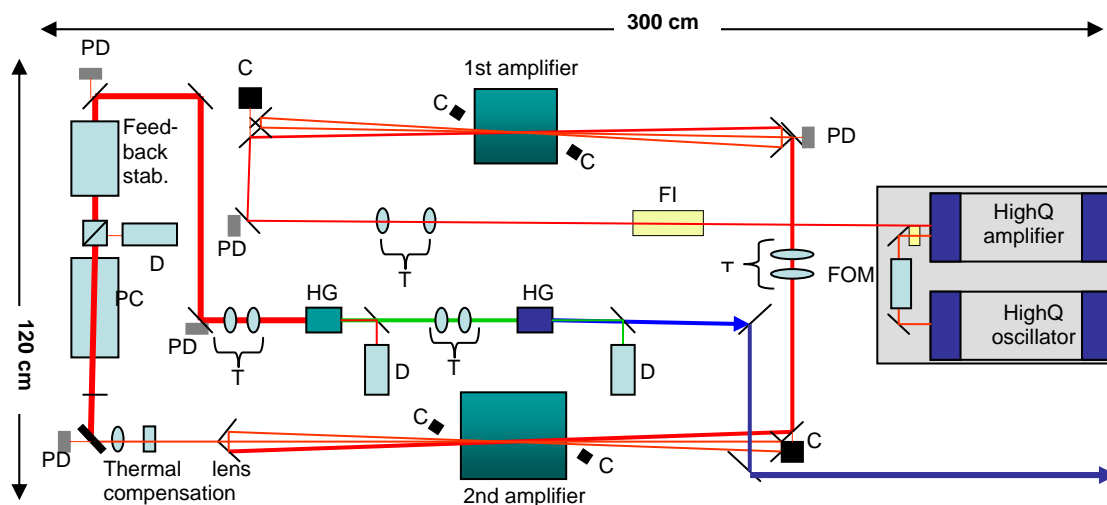

Figure 2: Layout of the laser system – FOM fibre optic modulator, FI Faraday isolator, T telescope, PD monitor photodiode, C monitor camera, PC Pockels cell, D diagnostics, HG harmonic generation crystal.

The coding scheme chosen for CTF3 uses a modulator (Photline Technologies) designed for the 1047 nm Nd:YLF wavelength. This switches the oscillator pulse train on and off, changing state every 140.7 ns. The output is split into two fibres, one of which is 141.03 ns (140.7 ns + 333 ps) longer than the other. The fibre outputs are then recombined to produce the coded pulse train. The subtrain amplitudes can be matched by varying the fibre bending losses and the delay can be tuned by adjusting the fibre temperature.

Each of the two 3-pass amplifiers consists of a water-cooled Nd:YLF rod, radially pumped by 802 nm light from 5 pulsed diode arrays (Dilas Diodenlaser GmbH). This wavelength choice minimises the sensitivity of the amplifier gain to diode temperature variations. The amplifiers are operated in quasi-steady state for maximum pulse energy stability. This is reached after  $\sim 300 \mu\text{s}$ , with the output from Amp 2 lasting for a further  $\sim 100 \mu\text{s}$ .

Nd:YLF is prone to thermal fracture, so for 50 Hz operation the overall heat load had to be carefully shared between Amp 1 and Amp 2. This set the design output power of Amp 1 at 3 kW within the pulse train. In experimental tests a value of  $>3.3 \text{ kW}$  was measured. The temporal profile of the output pulse train also matched the model predictions, thereby confirming the design. Amp 2 is now being assembled and tested.

The Pockels cell performs two functions. The first is to slice 2332 pulses from the train leaving Amp 2. The second is to reduce the average laser power at the HG crystals to a level which they can withstand. The chosen cell material is  $\beta$ -barium-borate (BBO). This is relatively immune to piezo-ringing effects which might otherwise distort the hard-won pulse energy stability. It can also handle high average laser intensities.

Despite the measures described above there will still be residual variations in the laser's output pulse energy. The level of this noise is difficult to predict but on the basis of the PILOT experience it is expected to be  $\sim 1\%$  rms. A

second, low-voltage Pockels cell will be used for noise suppression. Modelling suggests that, provided the initial noise is as expected, it should be possible to achieve a factor of ten suppression with  $\sim 90\%$  cell transmission.

The HG design is a compromise between high conversion efficiency (minimising the required infra-red laser power), low levels of other nonlinear effects (which could degrade the beam uniformity) and material durability at very high power. On this basis type I BBO has been chosen for both HG stages. An overall IR/UV conversion efficiency of  $\sim 7.5\%$  is expected.

## CONCLUSIONS

The CTF3 drive beam photoinjector involves many challenges: fast switching of high power laser beam, high average laser power, requirement for an extreme stability in phase and amplitude, high total charge in the pulse train. The laser and the RF gun, provided respectively by CCLRC and LAL will be integrated at CERN, who will also produce the photocathodes. Start of commissioning is foreseen in 2007.

## REFERENCES

- [1] R. Bossart, et. Al. "A 3 GHz photoelectron gun for high beam intensity", Nucl. Inst. and Methods, Vol A 375, ABS7-ABS8, 1996
- [2] J. Haimson et al., "A racetrack geometry to avoid undesirable azimuthal variations of the electric field gradient in high power coupling cavities for TW Structures", Advanced Accelerator Concepts, AIP Conf. Proceedings 398, New York, 1997
- [3] PARMELA from Los Alamos modified at LAL by B. Mouton.
- [4] I. N. Ross, M. Csatari and S. Hutchins, "High performance diode pumped Nd:YLF amplifier", Appl Opt 42 (2003) 1040.