



Large Hadron Collider Project

LHC Project Report 818

The LEIR RF System

R. Garoby, M. Haase, P. Maesen, C. Ohmori¹⁾, M. Paoluzzi, C. Rossi
CERN, Geneva, Switzerland

Abstract

The lead-lead physics program of LHC relies on major changes of the CERN ion injector chain. In this framework, the conversion of LEAR (low energy antiproton ring) into the Low Energy Ion Ring (LEIR) is central and implies a new accelerating system covering a wide frequency range (0.35 - 5 MHz) with a moderate voltage (4 kV). For this purpose two new wide-bandwidth cavities, loaded with Finemet® magnetic alloy cores, have been built in collaboration with KEK. Two 60 kW RF power amplifiers have also been built and the RF systems are now installed in the LEIR ring. They individually cover the whole frequency range without tuning and allow multi-harmonic operation. The design has been guided by need of safety margins, reliability and ease of maintenance. Some design aspects are presented as well as the performance achieved.

¹⁾ KEK, Tsukuba, Japan

Presented at
PAC 2005, Knoxville, USA,
May 16-20, 2005

CERN,
CH-1211 Geneva 23,
Switzerland

Geneva, June 2005

THE LEIR RF SYSTEM

R. Garoby, M. Haase, P. Maesen, M. Paoluzzi, C. Rossi, CERN, Geneva, Switzerland
C. Ohmori, KEK, Tsukuba, Japan.

Abstract

The lead-lead physics program of LHC relies on major changes of the CERN ion injector chain. In this framework, the conversion of LEAR (low energy antiproton ring) into the Low Energy Ion Ring (LEIR) is central and implies a new accelerating system covering a wide frequency range (0.35 - 5 MHz) with a moderate voltage (4 kV). For this purpose two new wide-bandwidth cavities, loaded with Finemet® magnetic alloy cores, have been built in collaboration with KEK. Two 60 kW RF power amplifiers have also been built and the RF systems are now installed in the LEIR ring. They individually cover the whole frequency range without tuning and allow multi-harmonic operation. The design has been guided by need of safety margins, reliability and ease of maintenance. Some design aspects are presented as well as the performance achieved

INTRODUCTION

The role of the LEIR RF is to bunch the accumulated lead ions and accelerate them to a point where they can be injected into the PS machine. The moderate ramping rate leads to a (peak) RF voltage of 4 kV with a frequency swing of 0.72 to 2.84 MHz for operation on harmonic $h=2$. Nevertheless, in the initial stages of operation, a scheme employing $h=1$ extends the lower frequency requirements to 0.36 MHz while to leave the possibility of accelerating other ion species, the high frequency limit is increased to 5 MHz. The acceleration ramp lasts ~ 1.2 s with a repetition rate of ~ 3.6 s. The wide frequency range and the small space available for installation, suggest the use of high-permeability materials and Finemet® is the magnetic alloy of choice because of the high value of its figure of merit, $\mu_p Q_f$, up to at least 200 mT. In addition, its very low quality factor, Q , allows the entire frequency range to be covered without cavity tuning and enables multi-harmonic operation. Extensive studies have been done at KEK laboratory [1] showing that the best choice of Finemet® material for this application is type FT-3M type.

DESIGN CONSIDERATIONS

Cavity and final stage output circuit

The RF cavity is a coaxial resonator with the accelerating gap in the centre (see Fig. 1). It is basically a push-pull device with a very loose coupling between the two cavity halves that imposes a differential drive and thus a push-pull configuration for the final amplifier.

At low frequency, the cavity gap impedance (see Fig. 2) is mainly dependent on the Finemet® characteristics and is strongly affected by the number of cores. At high frequency the response mostly depends on the system

capacitance. When connected to the final stage, the response is modified by the amplifier output impedance and by the way the amplifier is connected to the cavity so that the cavity and the amplifier design cannot be separated. A dedicated study [2] has led to the connection scheme shown in Fig. 3, the adoption of 6 cores and the use of two Thales tetrodes type RS1084CJ operated in class AB.

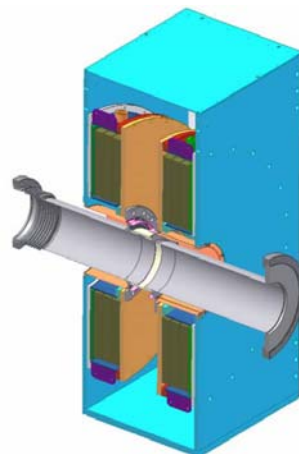

Figure 1: LEIR RF Cavity.

To achieve the 5 MHz high frequency response, particular attention has been paid to limit the overall circuit capacitance. In particular, the lines connecting the amplifier to the cavity have been chosen with high impedance ($\sim 100\Omega$) and with a tri-axial configuration that allows the use of their distributed capacitance to implement the passive gap voltage divider.

The RF chokes affect both the high and low frequency response. The inductance should be maximized but this requirement conflicts with the need of placing its first series resonance above the maximum working frequency and thus requires some compromise.

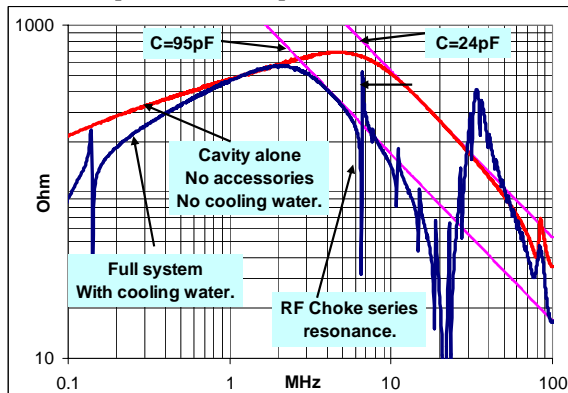

Figure 2: Cavity gap impedance.

The cores, whose surface is protected by means of epoxy coating and vinyl ester painting, are housed inside two separated water tanks and cooled by immersion in demineralised water. The RF path inside the cavity has been designed to allow the heating jackets for the vacuum chamber bake-out to remain in place during operation.

A gap relay, reacting in ~ 20 ms, reduces the gap impedance when the cavity is not used.

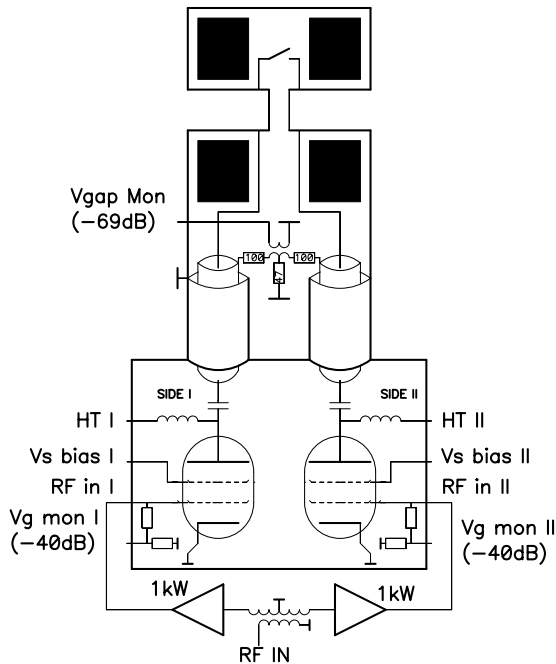

Figure 3: LEIR RF system simplified schematic

Drivers and final stage grid circuit

Each tube is independently driven in anti-phase by two 1 kW, 0.2 to 10 MHz amplifiers located outside the ring. The tube input circuit capacitances are compensated by an all-pass network and loaded with 50 Ω , 1.2 kW resistors. This gives an input matching better than 20 dB over the whole bandwidth and a driving chain response flat to within ± 1 dB. The low level transfer function from the RF input to the grid is given in Fig. 4.

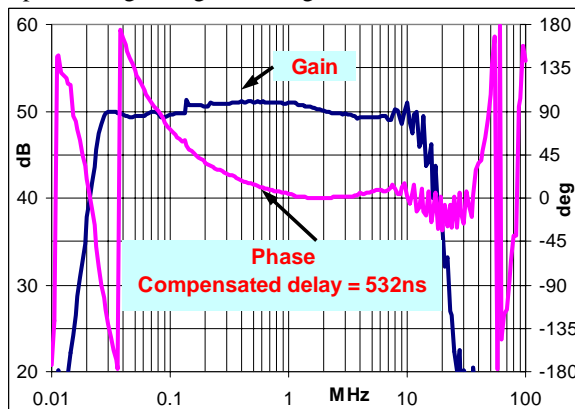

Figure 4: Input to grid transfer function.

Additional considerations

To ensure high reliability of the LHC ion injector, the different RF system components have been designed with ample safety margins and assuming CW operation. Particular attention has been paid to ensure easy and rapid maintenance.

While a sophisticated PLC interlock system continuously monitors many critical parameters, a fast ($< 100 \mu\text{s}$) over-current protection interlock avoids driving the system into dangerous conditions by removing the 1.5 kV screen bias and reducing the 1 kW driver gain by 20 dB.

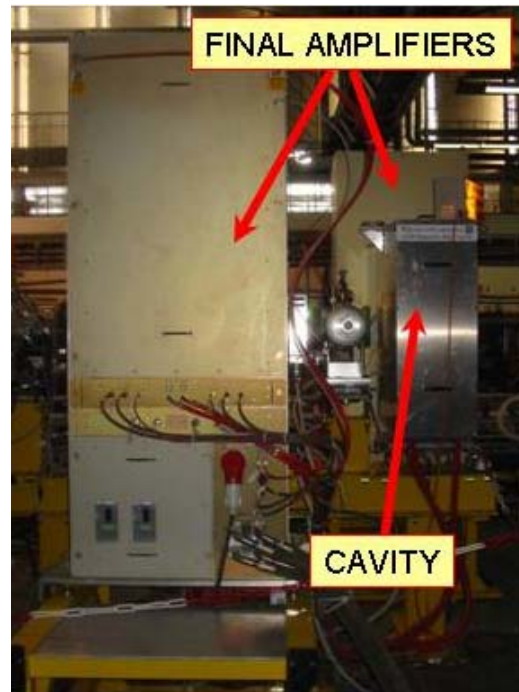

Figure 5: View of the LEIR RF systems

POWER MEASUREMENTS

Single frequency operation

Operation of the system did not show any particular weakness and all specifications could be met with comfortable margins. This is true in particular for the maximum voltage at 350 kHz, where 2 kV could be obtained instead of the 1 kV foreseen in the design report. Despite the good results, we should note that the high frequency capacitive component of the gap impedance is higher than expected: i.e. 95 pF instead of 70 pF. This strongly influences the required tubes current and plate power dissipation at maximum frequency, which increase by $\sim 30\%$ and $\sim 50\%$ respectively. Even under these conditions the system is well within the safe operation limits and can be operated in CW. The power available from the drivers is substantially over dimensioned. This helps to keep the harmonic distortion low and allows the system to be overdriven for short periods.

Table 1 lists the main parameters of the RF system while Fig.6 shows the overall frequency response at different gap voltage levels.

Table 1: RF system main parameters

Frequency	MHz	0.35	0.7	2	5.0
Nominal gap voltage	kV	2	4	4	4
Cavity power	kW	5	18	14	12
Cavity R_{gap}	Ω	390	450	570	660
Cavity $ Z_{gap} $	Ω	275	390	560	320
Max power density	W/cm ³	0.2	0.8	0.7	0.6
Average power density	W/cm ³	0.1	0.4	0.3	0.3
HV supply voltage	kV	5.5			
HV supply current	A	12	16	12	22
Plate power (each tube)	kW	30.5	35	26	55
Screen grid bias	kV	1.5			
Control grid bias	V	-225			
Plate rest current	A	3			
2 nd harmonic	dBc	-28	-28	-30	-30
3 rd harmonic	dBc	-25	-25	-35	-30
Grid power (each tube)	W	~120			
Cavity length	m	0.4			

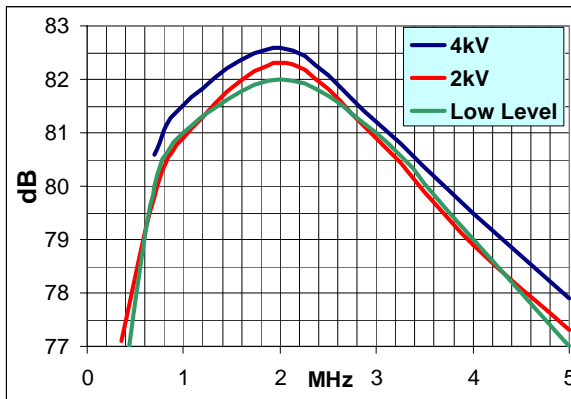

Figure 6: Overall gain

Multi harmonic operation

Acceleration with fundamental and second harmonic RF systems is a well known technique. It usually implies the use of separate, narrow-bandwidth, tuneable cavities working at the different harmonics. As mentioned above, the Finemet® loaded cavities exhibit a wide bandwidth response that can be exploited to generate the different harmonic components with a single cavity. This technique already tested in HIMAC with fundamental, second and third harmonics [3], is foreseen for LEIR too. The low level electronics presently under development [4] will operate with fundamental and second harmonics and will also implement RF feedback at the two frequencies.

The RF system has therefore been successfully tested for this kind of operation over the full frequency range

and Fig. 7 shows an example of the gap voltage and its FFT.

The loose coupling between the two cavity halves and the class B operation, are such that each tubes basically supplies most of the current required to generate a half waveform cycle. The addition of the second harmonic component can lead to strongly unbalanced operation of the two tubes and some conditions might require an increase of the HV supply to 6 kV or more. The plate power dissipation would thus increase but since the duty-cycle during operation is below 50 %, this is not expected to be a practical limitation.

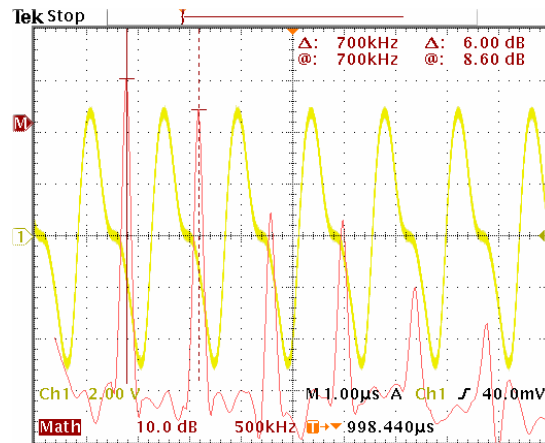

Figure 7: Gap voltage at 700 kHz with second harmonic
Vertical scaling is 0.9kV/V

CONCLUSIONS

A new set of RF cavities and their power amplifiers has been installed and tested in the LEIR machine. They meet all the specifications and are ready for the beam commissioning during summer 2005. This was the result of a fruitful collaboration between KEK and CERN.

ACKNOWLEDGEMENTS

We are grateful to Prof. Y. Mori, Mr. Y. Funahasi, S. Koike and the J-PARC RF group for the design and construction of the cavity. We also express special thanks to Mr. Ogura and Dr. K. Bessho for the improvement of the water-proof coating technology.

REFERENCES

- [1] Y. Tanabe et al., "Evaluation of magnetic alloys for JHF RF cavity", in Proc. APAC1998 Conference, Tsukuba, 23-27 March 1998
- [2] M. Paoluzzi, "LEIR power amplifier design", CERN, AB-Note-2003-029 RF, Geneva, April 2003
- [3] C. Ohmori et al, "A Multi-Harmonic RF System using A MA Cavity", will be published on Nucl. Instr. and Meth. A.
- [4] Maria-Elena Angoletta et al., "Beam tests of a new beam control system for the CERN LEIR accelerator", in this conference.