

15-2-86

B. DULACH

G. SENSOLINI

ALEPH

Barrel Muons Detector

Technics description

- 1) introduction
 - 2) structure of the container
 - 3) container distorsion
 - 4) container characteristics
 - 5) container mounting and alignment
 - 6) costs and construction times
- figures 1-2-3-4-5-6-7-8

1.- Introduction

In order to obtain information better than the digital information obtained from the barrel strips, two more double layers of streamer tubes with reading strips were added around the external part of the barrel. This configuration allow the identification of the muons' tracks that cross the whole barrel and of their angles.

Figure 1 shows the position of the tubes containers around the barrel. They are placed on two parallel planes of radius $R_i = 4744$ mm and $R_e = 5264$ mm. These radii refer to the center of the containers.

The radial distance of the tubes plane with respect to the center of the container varies according to the angular position of the container and goes from + 10 mm for the upper and lateral containers to - 42 mm for the lower ones (the + or - sign refers to the greater or lesser distance from the first layer of tubes to the axis of the beam. See figure 2.

The dead angles on the plane normal to the beam, due to the lateral containers support and to the cables outlets on the barrel, have been kept to an absolute minimum. Figure 3 shows both the external and the internal angles. The sum of these angles is about 18 degrees for the internal ones and about 44 degrees for the external ones. The dead angles due to the empty space left by the tubes inside the individual container (of which we will speak below) are also included in this sum. Four other dead angles due to the supporting struts of the barrel, each of which covers about 30 degrees on the plane normal to the beam axis and approximately 15 degrees on the plane passing through the axis of the beam are also to be taken into consideration.

2.- Structure of the containers

A structure that combines a low weight with an adequate moment of inertia has been studied in order to restrain the elastic deformation of the containers within the required 5 mm.

An aluminium structure made up of square tubes and commercial sheet metal held together with a combined system of "pop" aluminium rivets and self threading steel rivets was chosen. This structure is rigidly anchored to two lateral aluminium bars which in turn house the system anchoring the container to the barrel supports and the holes for attaching the lifting and installing equipment. Figure 4 is an artistic rendering of the structure of a conventional container.

3.- Container distortion

The high ratio between the distance of the container supports and their transverse dimension, approximately 33:1 is the cause of radial distortion, which for the container under greatest stress has been kept within the required 5 mm. The distortions of the individual containers, which depend on that containers angular position, were measured on a full scale prototype. Detailed information on this subject can be found in note 1.

4.- Container characteristics

In order to satisfy the different needs and limitations deriving from the complex geometry of the barrel, containers of differing dimensions and shapes were studied. Figure 8 shows such shapes , the dimensions refer to the useful surface for the tubes. The construction characteristics for each type of container are shown on drawings ALEPH7/1, 7/2 , 7/3 for the internal ones and ALEPH 7/4,7/5,7/6,7/7,7/8 for the external ones. Figure 5 schematically shows the stratigraphy of the reading strips and the tubes inside the container. Looking from the beam we find:

X axis reading strips

streamer tubes

2 planes of Y axis reading strips

streamer tubes (staggered 5 mm with respect to those above)

X axis reading strips

Using this configuration as a base, the maximum number of tubes (per layer) that can be inserted in each type of container and the relative dead space which can be used for cables passage was calculated. In the table below the following data is listed:

- position of the containers around the barrel (see figure 1)
- number of containers which are alike
- actual dimensions for the insertion of the tubes in mm (see figure 6)
- number of tubes that can be inserted in each container
- free space on A dimension in mm
- total weight(container+ tubes) in daN (Kg)

position	number	dimensions	quantity	space	weight	note
		Amm Bmm		mm	daN	

internal containers						

3i 4i 5i	9	2437 6966	29+29	30	1000	standard
6i 8i 10i						
11i 12i 13i						
7i 9i	2	2437 3180	29+29	30	450	between the legs
alongside	4	2437 1030	29+29	30	150	never considered
the legs						
11 2i	2	932 6966	11+11	18	550	shaped on the top
		250 5895	3+3			

external containers

3e 4e	4	2715	6966	32+32	59	1050	standard
12e 13e							
7e 9e	2	2715	3180	32+32	59	500	between the legs
alongside	4	2715	1030	32+32	59	200	never considered
the legs							
1e 2e	2	1075	6966	12+12	70	600	shaped on the top
		250	5895	3+3			
5e 6e	4	2500	6966	30+30	10	1000	cables exit
10e 11e							
8e	1	2715	6400	32+32	59	1050	the lowest

In order to avoid interference between the cables that come out of the barrel's modules and the streamer tube cables it is advisable that the latter exit from the containers at the hatched areas in figure 6.

5 mm of the figure for free space in the table are to be used for the staggering of the planes of the tubes.

The length of the tubes, including the electronics the gas linkages and the various attachments, must not exceed the dimension indicated by the letter "B". The available height, indicated by the letter "C" is 34mm for all the containers.

The weights of the chambers were calculated based on the tubes weighing 9.5daN/sq m (0.8daN/m) and the strips weighing 2daN/sq m

Listed in the table below is the total number of tubes of each length for the 34 containers.

length of tubes B mm	quantity of tubes
6966	1110
6400	64
5895	24
3180	244
1030	488*

*These tubes are for the chambers alongside the legs which have never been considered.

5.- Containers mounting and alignment

Special equipment capable of placing the containers in the final and angular correct position will be used for mounting them. A system installed on the support structure and made up of a series of cams, guarantees the anchorage of the containers to the support structure.

The final position of each single container will be read with respect to the three major axes, X, Y, Z (see figure 1) with a tolerance of +/- 1mm.

Because the length of the container is less than that of the barrel's modules special brackets have been studied to be mounted at the four corners of the containers that will compensate for this difference. These brackets have a calibrated hole 10mm in diameter, H8 in precision (+0.022 ; 0) and 20mm deep, in which a small plate, which serves as a reference for reading the position, is inserted. Figure 7 shows the position of the reference marks on the container and on the barrel modules and their coordinates.

Because of differing requirements, 13 containers have differing shapes and dimensions and because of this, special procedures must be used to read their position. The position of these containers and their peculiarities are listed below.

1i 1e	laser+helium
2i 2e	laser+helium
5e	cables exit
6e	cables exit
7i 7e	barrel's legs
8e	end cap's jacks
9i 9e	barrel's legs
10e	cables exit
11e	cables exit

6.- Costs and construction times

The construction cost (including material) was calculated using the cost incurred for the construction of a prototype of the standard internal container as a reference (approx. 7.5 MI-9'000Sf). There are a total of 26 containers including both standard and special ones, of which 13 are internal and 13 external. The construction cost is then $26*7.5=195\text{MI}$ (234'000Sf). It is then necessary to add about 25MI (30'000Sf) for equipment, bringing the total to 220MI (26'400Sf). The cost of the aluminium is about 50/100 of the total.

The eight containers alongside the legs which have never been considered are not included in this cost.

Construction time is estimated at approximately 5 months which means they will be at Frascati Labs, ready for the insertion of the streamer tubes, within 1986.

In conclusion please note that in order to have the laser for the TPC (time projection chamber) calibration installed, it is absolutely necessary that the four μ chambers below the laser,(2 internal and 2 external) be previously mounted in their final position.

Note 1: B. Dulach-Barrel muon detector-Transverse test on μ detector container-Aleph Layout 14-1-86

e=external
i=internal

Muon Chambers

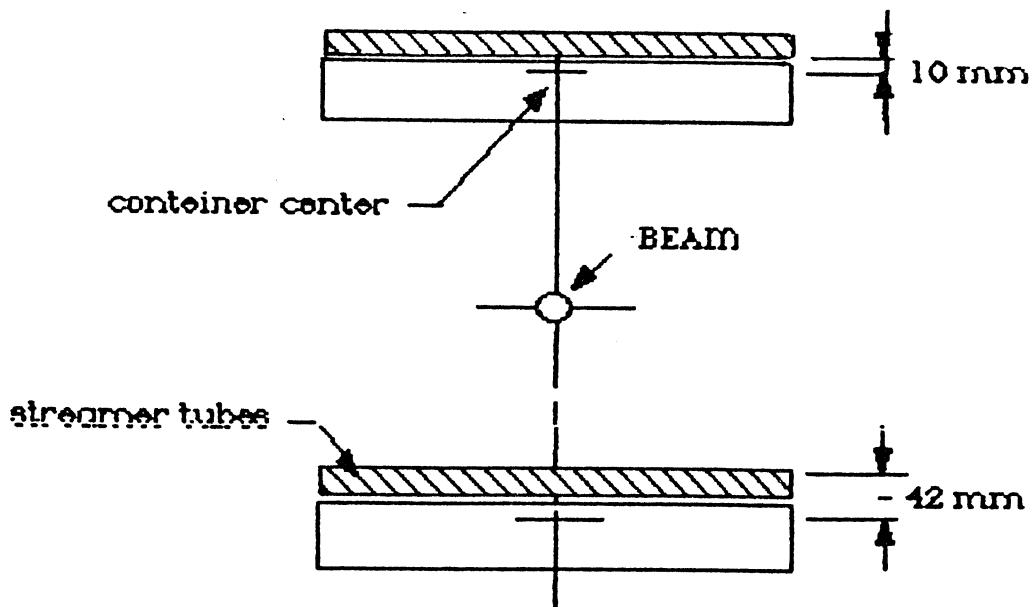
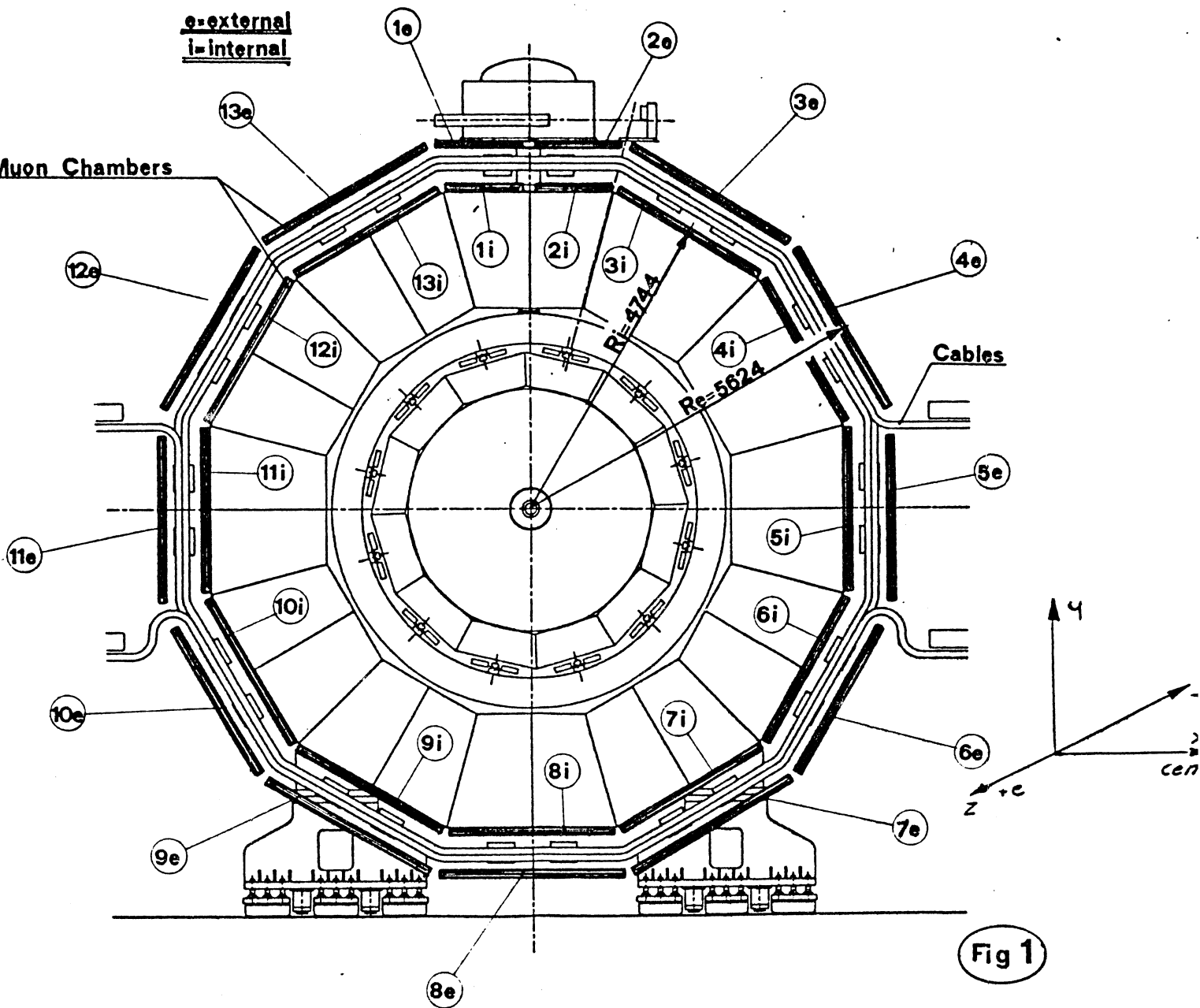

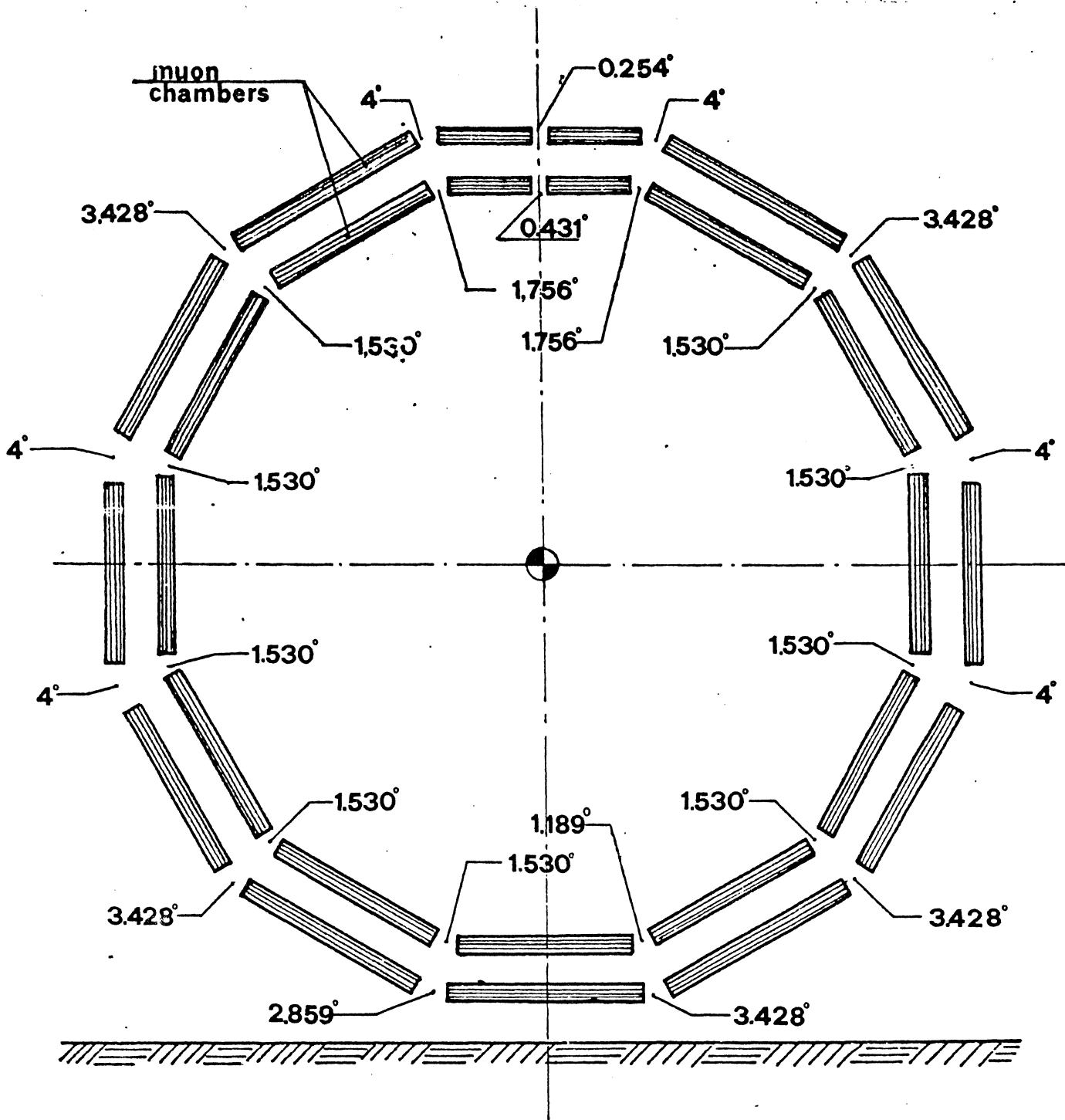

Fig. 3

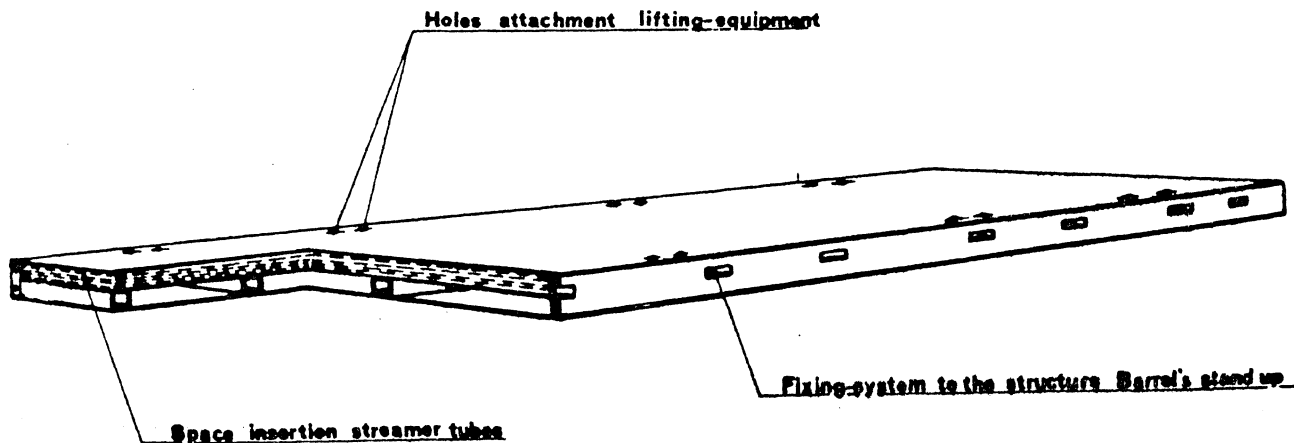
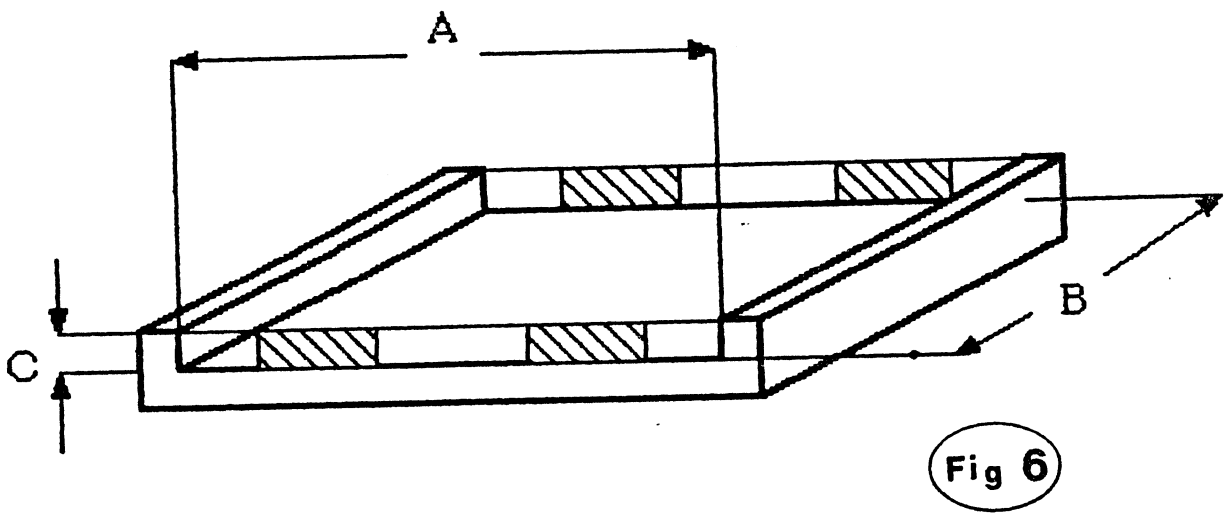
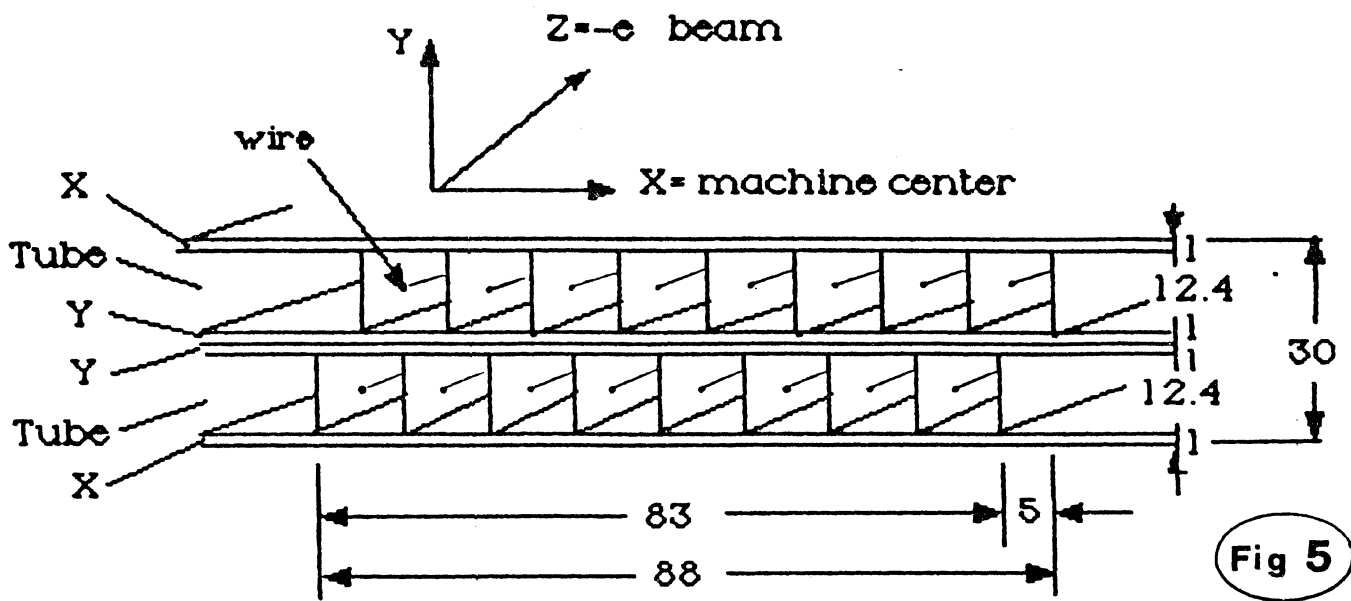

Fig 4



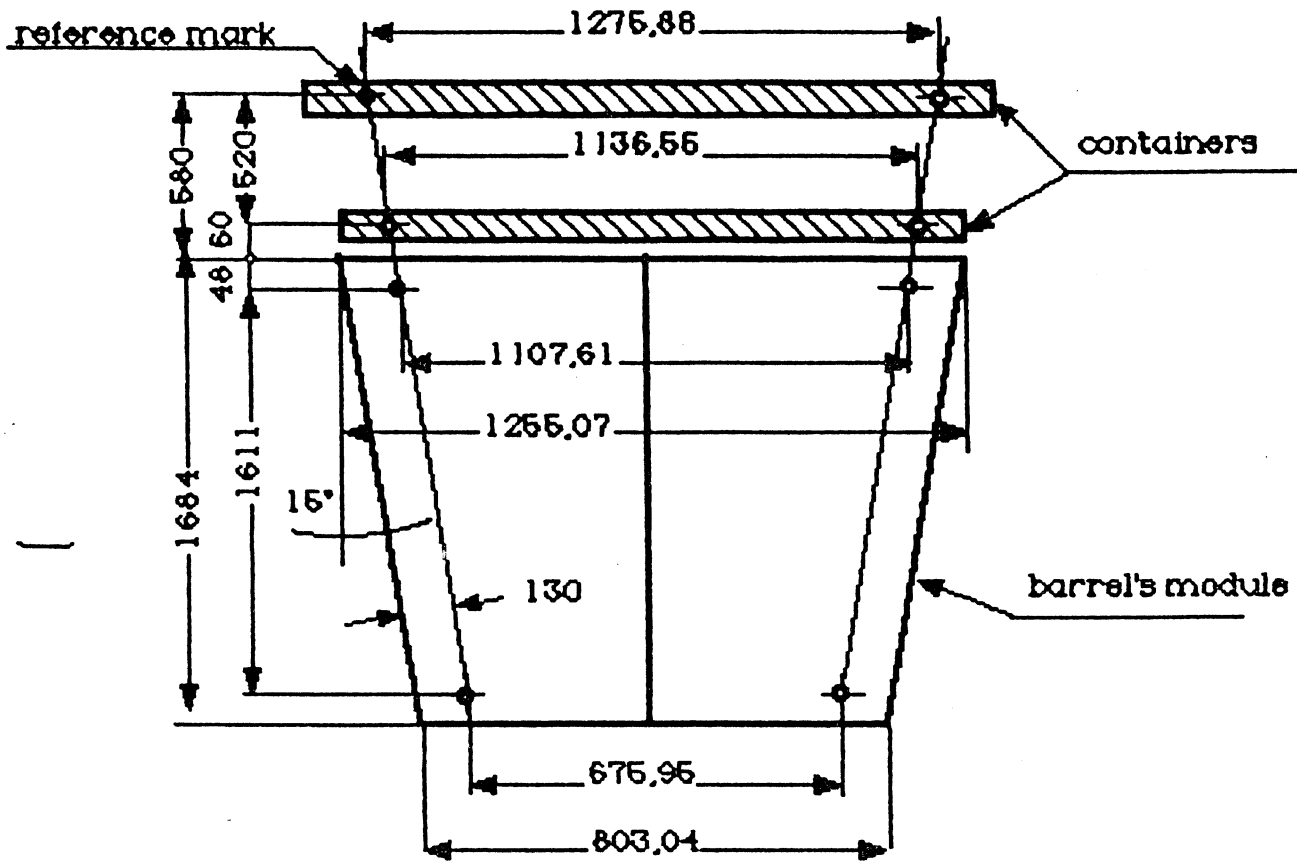
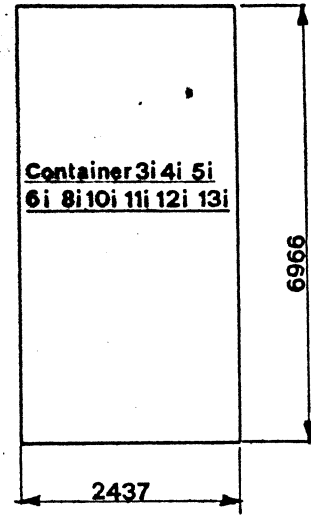
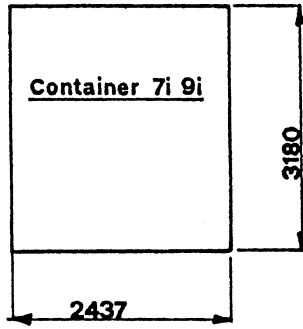
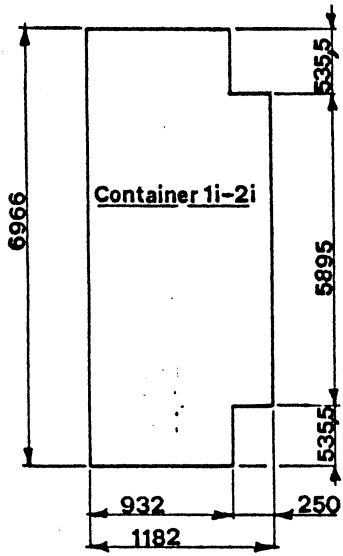

Fig 7

INTERNAL CONTAINERS



EXTERNAL CONTAINERS

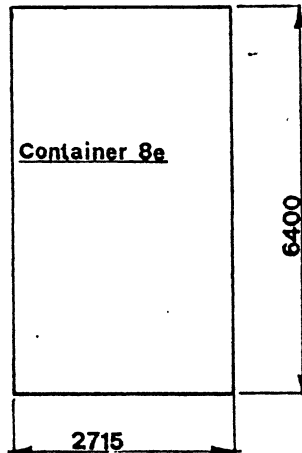
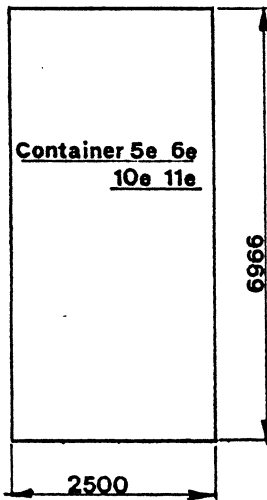
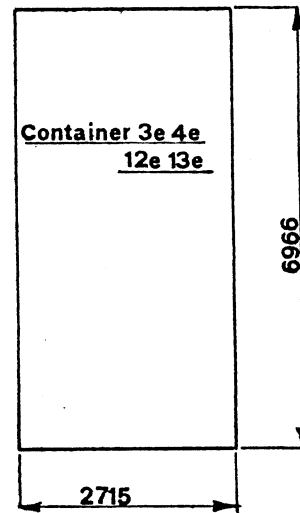
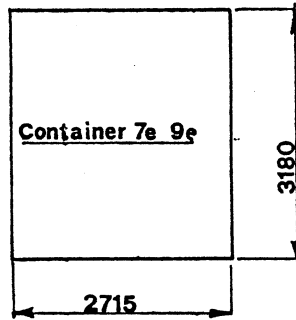
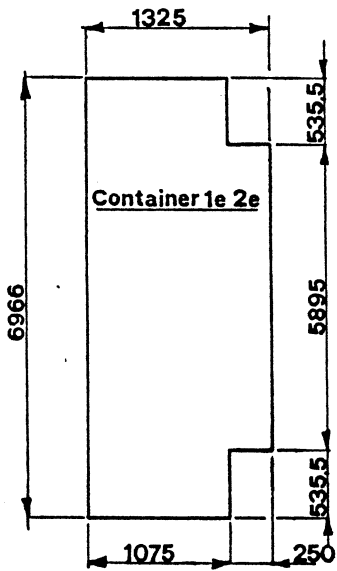

FIG. 8