

DD

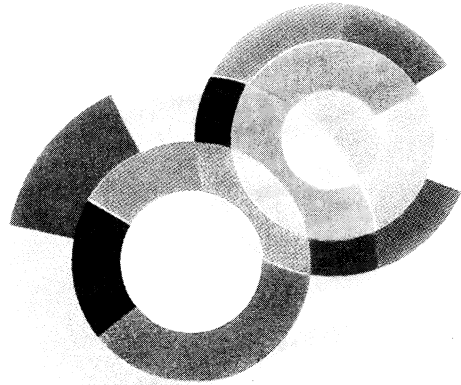

DAPNIA



CERN LIBRARIES, GENEVA



CM-P00048626

DAPNIA-03-79

April 2003

Calibration and production of praxial sensors for the ATLAS muon spectrometer

Ph.Schune, J.-Ch.Barrière, O.Cloué, B.Duboué,
M.Fontaine, V.Gautard, P.Graffin, C.Guyot, G.Jiolat,
P.Perrin, P.Ponsot, Y.Reinert, J.C.Saudemont, J.-P.Schuller

*Will be presented at the Conference on Optical Metrology, Optical Measurement
Systems for Industrial Inspection, Munich (Allemagne), June 23-26, 2003*

Département d'Astrophysique, de Physique des Particules, de Physique Nucléaire et de l'Instrumentation Associée

DSM/DAPNIA, CEA/Saclay F - 91191 Gif-sur-Yvette Cédex

Tél : (1) 69 08 24 02 Fax : (1) 69 08 99 89

[http : //www-dapnia.cea.fr](http://www-dapnia.cea.fr)

Calibration and production of praxial sensors for the ATLAS muon spectrometer

Ph. Schune¹
for the Saclay hardware alignment group²

CEA-Saclay
DAPNIA-SPP,
91191 Gif sur Yvette Cedex
France

Abstract: The future LHC experiment, ATLAS [1], features a muon spectrometer in which the alignment system must control the spatial position of the muon chambers with an accuracy of $30\mu\text{m}$ and $200\mu\text{rad}$ in a range of displacements of $\pm 5\text{mm}$ and $\pm 5\text{mrad}$. The alignment system described in this paper, called *praxial*, fulfils these requirements. The paper reviews the relative and absolute calibration procedures and the production of the 1005 praxial sensors needed in ATLAS.

Keywords: alignment, muon, optical system, absolute positioning, micron precision

1) Alignment requirements for the ATLAS muon spectrometer

ATLAS is an LHC (Large Hadron Collider) experiment, located at CERN (European Laboratory for Particle Physics). One part of this experiment, the muon spectrometer, is devoted to muon detection. The muon momentum measurement in the ATLAS spectrometer aims at a precision of the order of 10% for muons of momentum 1 TeV. It proceeds with a sagitta measurement using triplets of precision Monitored Drift Tube chambers separated on average by 5 meters. The accuracy needed for the precision chamber alignment is such that the alignment contribution to the final sagitta measurement error must stay below the intrinsic chamber measurement error of $50\mu\text{m}$. The goal is to control the spatial position of all muon chambers with a spatial accuracy of $30\mu\text{m}$ and $200\mu\text{rad}$ for a range of displacements of $\pm 5\text{mm}$ and $\pm 5\text{mrad}$. This challenging accuracy is required in order not to degrade the reconstruction of the muon momentum mainly above 100 GeV/c.

Fig. 1 [2] shows a 3D view of the barrel part of the ATLAS spectrometer and Fig. 2 shows a MDT chambers.

¹schune@hep.saclay.cea.fr, tel: +33 (0)1 69 08 70 61, fax: +33 (0)1 69 08 64 28.

² Saclay team involved in this development: J.-Ch.Barrière, O.Cloué, B.Duboué, M.Fontaine, V.Gautard, P.Graffin, C.Guyot, G.Jiolat, P.Perrin, P.Ponsot, Y.Reinert, J.-C.Saudemont, J.-P.Schuller, Ph.Schune

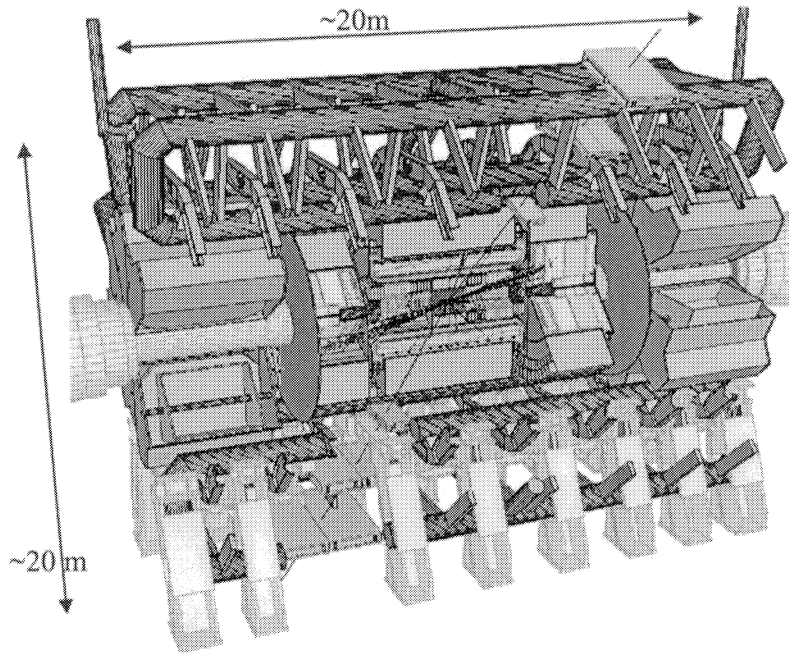

Fig. 1: This drawing shows the barrel part of the ATLAS experiment surrounded by the muon spectrometer (only a few Monitored Drift Tube chambers (MDT) are drawn). The muon spectrometer is made of eight magnet coils, each $\sim 20\text{m}$ long and $\sim 5\text{m}$ wide, assembled in a toroidal configuration. Charged particles trajectories, in particular muons, are bent and detected by Monitored Drift Tube chambers (see Fig. 2). A simulated event: $H \rightarrow Z^0 Z^0 \rightarrow e^+ e^- \mu^+ \mu^-$ is superimposed to the detector.

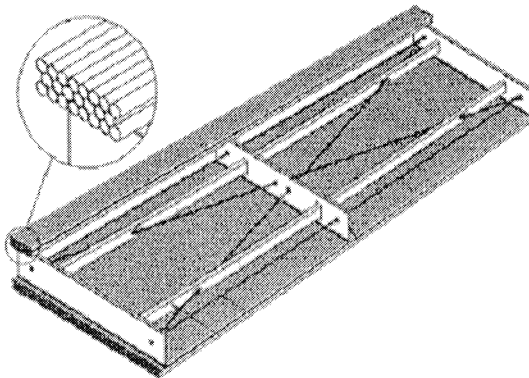

Fig. 2: This drawing shows a Monitored Drift Tube chamber (MDT). A MDT is made of 100 to 300 individual drift tubes, each 3mm in diameter, and assembled in two times three layers separated by a mechanical support. The sizes of MDTs vary from $1.5 \times 2\text{m}^2$ to $2.5 \times 5\text{m}^2$.

2) The Praxial sensor

Most of the alignment devices are based on an optical system called Rasnik [3] working with a square coded mask² seen through a lens by a (CMOS) camera. Such an alignment device provides the relative transverse position of the mask, as seen by the camera, with an accuracy of $\sim 1\mu\text{m}$. The camera angular orientation with respect to the mask axis can be reconstructed with an accuracy of $100\mu\text{rad}$. Finally, the image magnification is determined by the mask pitch as recorded by the camera, relative to the (known) original mask pitch. The accuracy on this parameter, called magnification, is 10^{-4} to a few 10^{-5} . A Rasnik system is thus able to measure four parameters: two transverse coordinates, a rotation and a magnification.

Optical sensors based on this principle and assembled in ad-hoc layouts are used to reconstruct the absolute positions of ATLAS chambers. In particular, the praxial sensor (see Fig. 3 and 4), one of the key elements of the alignment system which aims at the measurement of the relative position of two adjacent chambers, works with two crossed Rasniks, where the optical components of each system sit on two elements each on two neighbouring MDT chambers: the camera and the lens on one element and the corresponding mask on the other element (and vice versa for the second optical system, see Fig. 4).

There are four praxial elements per chamber, one at each corner except for chambers at the detector edges where there are only two praxial elements.

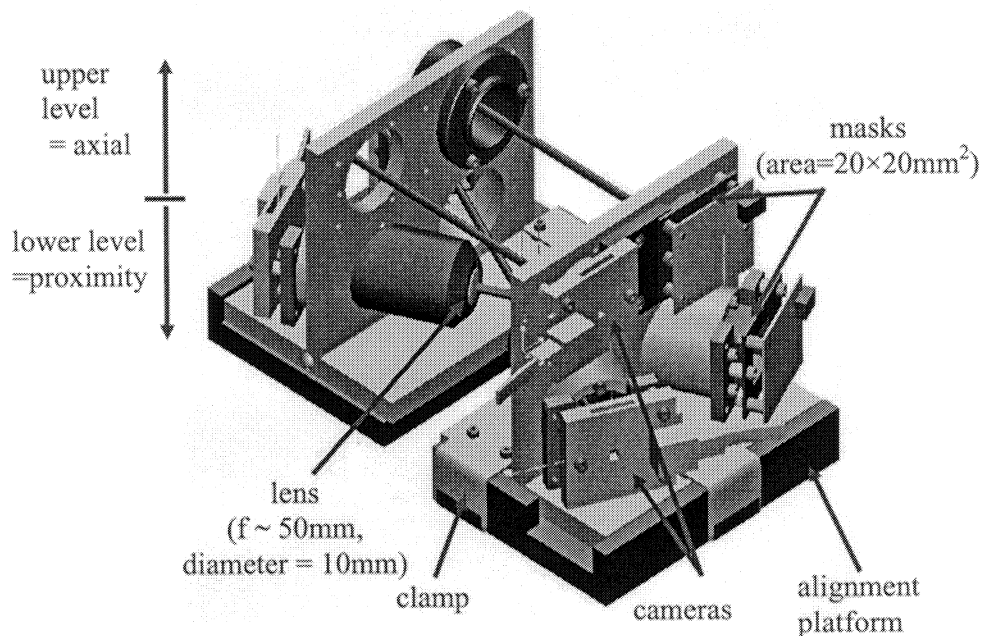

Fig. 3: The praxial sensor is made of two different elements and uses two crossed Rasnik at their "lower" level. The upper part of the sensor corresponds to the axial alignment which is used to unite a complete layer of MDT chambers (not describe in this paper). One of these two elements is on a chamber and the other one is on the neighbouring chamber. Each element is positioned on the MDT chamber through an alignment platform.

² The mask is a chessboard like drawing with $170\mu\text{m}$ pitch.

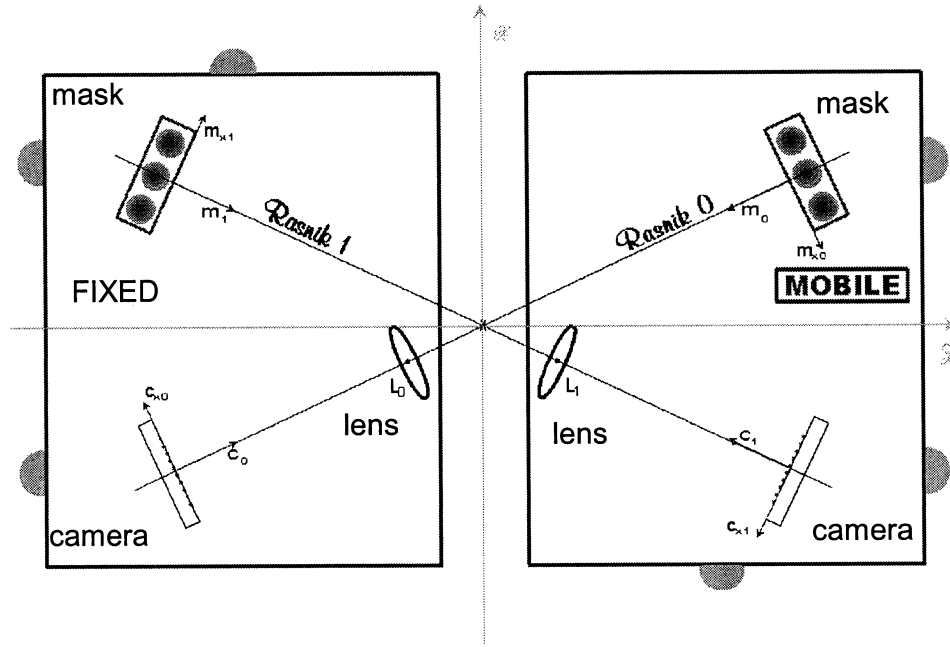

Fig. 4: Drawing of the praxial sensor. One clearly sees on this top view the two crossed Rasnik. During the calibration procedure, the element on the left, called “fixed”, is the reference whereas the element on the right, called “mobile”, is positioned at different known positions thanks to the six stages of the test bench (see text for the calibration procedure). The distance between the camera and the lens is $\sim 70\text{mm}$.

The focal length of the lens in a praxial Rasnik is typically 50mm , the coded mask pitch is $170\ \mu\text{m}$ for a total area of $20 \times 20\text{mm}^2$; the camera area is $\sim 3.5 \times 4.5\text{mm}^2$, each pixel of the camera is 12 by $12\ \mu\text{m}$ [3]. Due to the local particularity in the layout of the ATLAS experiment, the distance between two neighbouring chambers and thus between the two praxial elements, varies from about 20mm to 400mm . This means that the magnification parameter of a given doublet goes from $1/1.3$ (for 20mm) to $1/7.3$ (for 400mm).

At a given position, the two Rasniks of the praxial system give two times four outputs. We shall see that after a calibration procedure as described below, the six degrees of freedom of one element with respect to the other neighbour are completely constrained by these eight measurements. The requirements for the praxial sensor resolution in ATLAS is given in Table 1. The X axis corresponds to the MDT wire axis and the Y axis is perpendicular to the chamber plane.

	Translation (μm)	Rotation (micro-radian)
X	100	100
Y	10	500
Z	10	500

Table 1: The praxial resolution needed for each local MDT chamber axis (see text).

3) Calibration of the Praxial sensor

To calibrate the praxial sensor doublets with the required resolution (see Table 1), we have developed and built a calibration set-up and the corresponding software working on the following principle:

- i) one of the two praxial elements is moved about one hundred times in all directions (three rotation axis and three translation direction) with respect to the other fixed one,
- ii) each relative displacement is measured by eight mechanical precision probes ($<2 \mu\text{m}$),
- iii) data from both Rasniks are recorded for each displacement,
- iv) using the eight Rasnik measurements at each position and all known relative displacements from the mechanical probe measurement a global fit is performed which provides a calibration matrix A to be used for determining the absolute position D (three rotation and three translation components) of one praxial element with respect to the other through the relation:

$$D = A \times R + d$$

where R is the column vector of Rasnik measurements (8 lines, 4 per Rasnik system); d is a column vector of 6 elements describing the offset of the two reference frames of the praxial elements; A is the calibration matrix (8 times 6).

Figure 4 and 5 show the calibration set-up in particular the micrometric stages used to move one of the praxial elements and the mechanical probes.

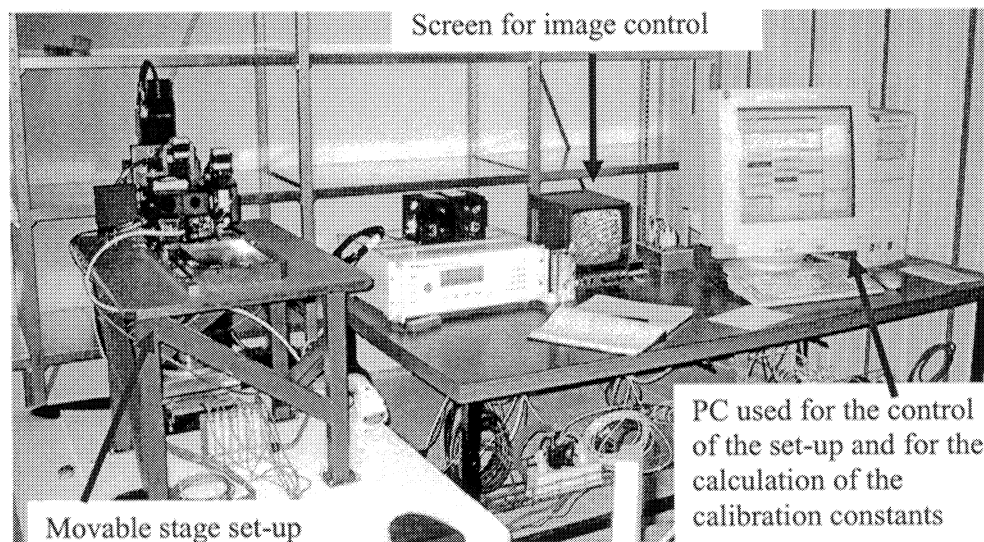
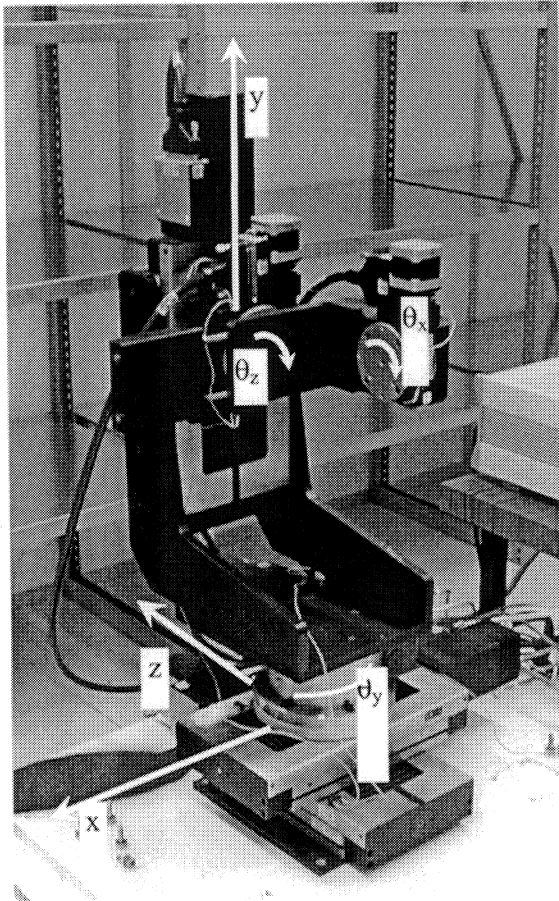
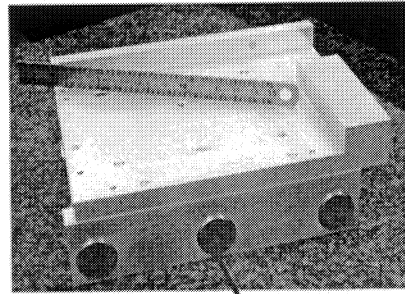

Fig. 4: The praxial sensor calibration bench: on the left of the picture are the 6D micrometric stages (Δx , Δy , Δz , θx , θy , θz) used to move one praxial element with respect to the other. The mechanical probes used to accurately measure the displacements are located below the aluminium plate. On the right of the picture we see the PC used to control the set-up and to calculate the calibration constants.

The simulation has shown that we need to do several tens of movements (~ 50) in order to obtain the required accuracy on the 48 elements of the calibration matrix. These movements should be in the $\pm 3\text{mm}$ and $\pm 3\text{mrad}$ range, where the system remains linear [4]. Even with such a reduced range during the movement phase, the calibration is valid in the $\pm 5\text{mm}$ and $\pm 5\text{mrad}$ range. The same simulation has also shown that the dimensions of the mobile support (see Fig. 5) have to be known with a $5\mu\text{m}$ accuracy in order to calculate with precision the relative movement of the mobile praxial element.



Six stage elements: three for rotations and three for translations.



Mobile support with some of its (round) flat reference surfaces. These surfaces are in contact with the mechanical probes.

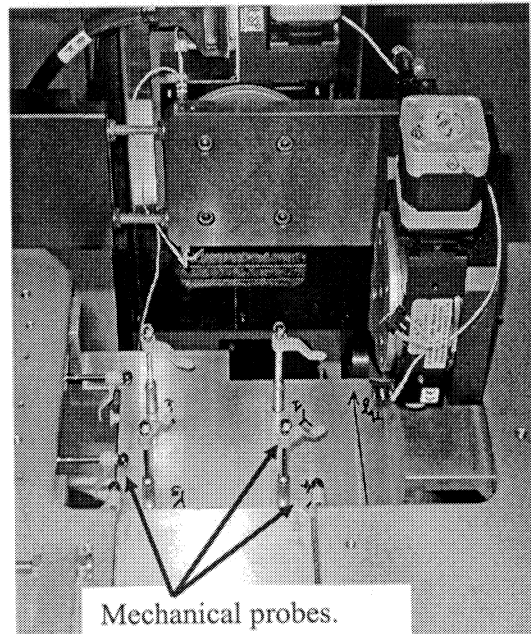

Mechanical probes.

Fig. 5: Three pictures showing different parts of the praxial calibration bench. Left: micrometric and micro-radian stages: three for translations and three for rotations. The axis of movement of each stage is shown on the picture. Top right: the mobile support attached to the last stage, the one used for θ_x movements. This mobile support mimics the platform attached to a MDT chamber. On this mobile platform, some reference (round) plates are shown (flatness $\sim 1\mu\text{m}$, 30mm in diameter), with which mechanical probes are in contact. Bottom right: expended view (without the mobile platform) of the mechanical probes. Eight are used for redundancies. The dimensions of the mobile support are known with $\pm 5\mu\text{m}$ precision which makes it possible to accurately calculate the support movements thanks to the probes.

The offset d is determined by using a special common mechanical support called zeroprax (see Fig. 6) where the two praxial elements are placed at a fixed relative position known with a $\pm 5\mu\text{m}$ accuracy (controlled with a Coordinate Measurement Machine, CMM).

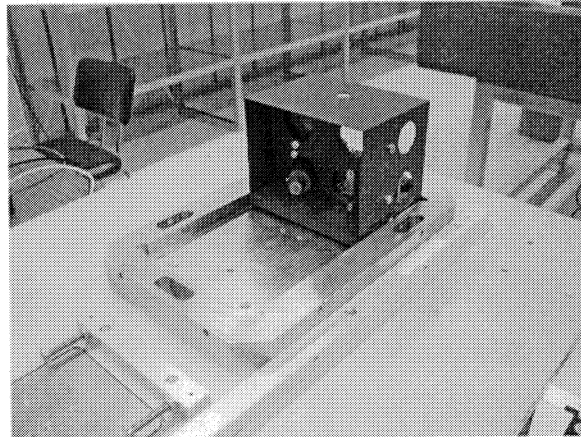

Fig. 6: This picture shows the mechanical reference support ($\sim 150\text{mm}$ by $\sim 300\text{mm}$), called "zeroprax", used for defining a common absolute frame for two praxial elements. The 3D mechanical precision of this support is $\pm 5\mu\text{m}$. In this picture only one praxial element is in position (the remote one).

A software program has been written in order to control the calibration set-up (including zeroprax measurement): edit stickers for the praxial elements numbering, check all steps of the calibration, control temperature probes during the calibration, calculate calibration parameters, record parameters in the data-base, etc... [5].

4) Stability of the set-up results

The good mechanical stability of the system during a calibration is very important. An example of a stability period recorded during four hours is shown in Fig. 7. This stability is better than $1\mu\text{m}$ for translations and $10\mu\text{rad}$ for rotations. Small oscillating variations can be seen for translations due to the air-conditioning system which has a working period of 20 minutes. The amplitude of these oscillations is well below $1\mu\text{m}$ and thus negligible.

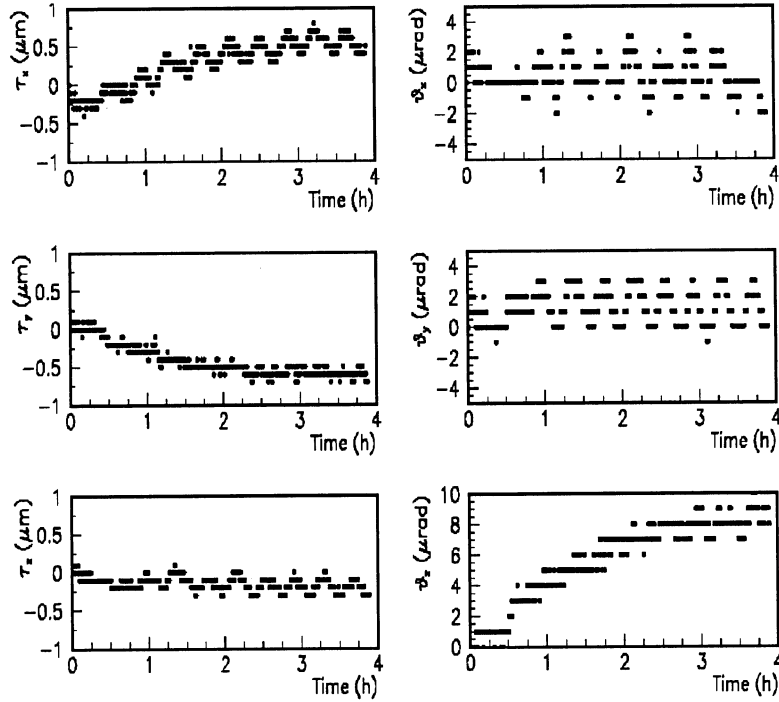

Fig. 7: This figure shows the good stability of the calibration set-up during a four hour period: below $1\mu\text{m}$ in translation and below $10\mu\text{rad}$ in rotation. Left (resp. right) column shows calculated translations (resp. rotations). These translations and rotations are obtained from the mechanical probe readout, where the first recorded event is taken as reference.

5) Calibration results

The final precision of the praxial optical sensors is summarized in Fig 8 [4]. The absolute space position of one element with respect to the other is below $10\mu\text{m}$ r.m.s. and below $100\mu\text{rad}$ r.m.s. for a range of displacements of $\pm 5\text{mm}$ and $\pm 5\text{mrad}$.

If we wanted a praxial sensor to work in a larger range another strategy for the calibration would have to be used [6]: one should fit the positions of each optical element (mask, lens and camera). For this new calibration:

- i) the lens is assumed to be described by one point (the optical centre),
- ii) the camera by one point and one angle (the pixel axis),
- iii) the mask by one point and three angles (two describing the angular position of the mask with respect to the camera-lens axis and one angle for the mask rotation).

Unfortunately, this new strategy for the calibration (compared to the one explained in the previous section) is more complicated since parameters describing the optical components position are highly correlated. However, since the range of the praxial optical sensor is already large enough for an ATLAS application, this strategy has been partially studied but is not used in the final calibration bench. The consequence is that as soon as two elements have been calibrated together to form a praxial sensor, one should always use these two elements together. Thus, in case of a failure of one praxial element, one should replace both elements.

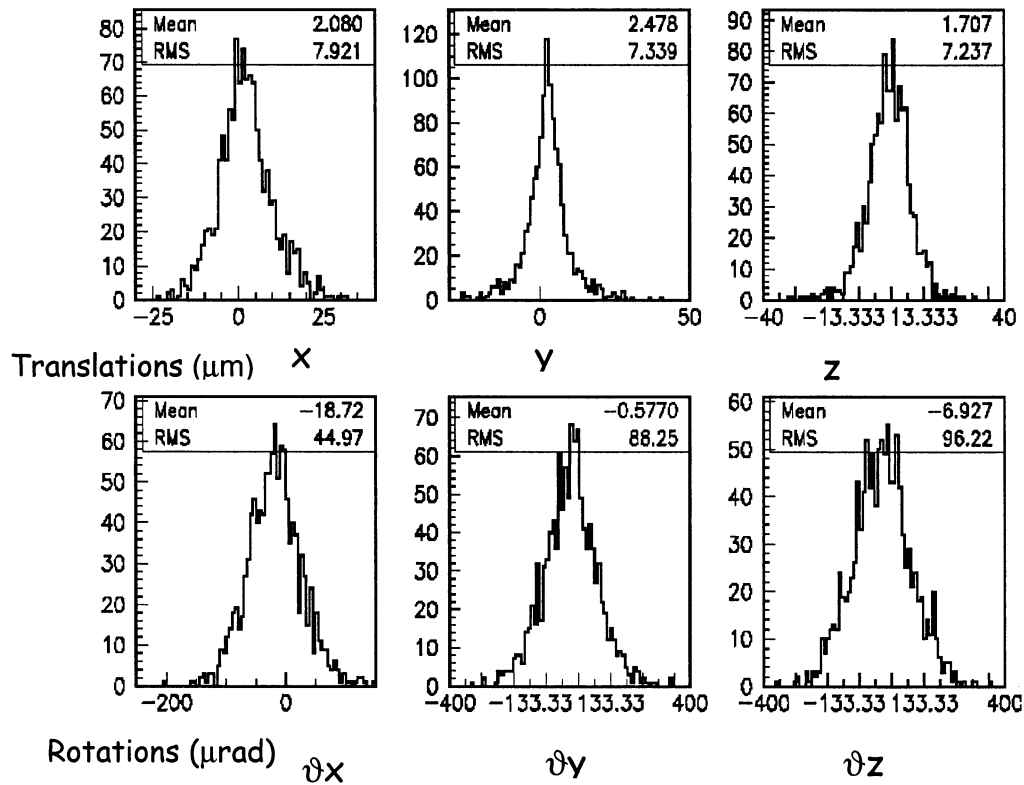

Fig. 8: Resolution obtained with the praxial sensor with thousands of random positions after a calibration procedure was performed as explained in the text. The r.m.s. is below $10\mu\text{m}$ on translation and below $100\mu\text{rad}$ for rotations.

6) Production of praxial sensors for ATLAS

For the ATLAS experiment we need to produce and calibrate 2010 elements i.e. 1005 praxial sensors. As already mentioned, due to particularities of the ATLAS layout, distances between two neighbouring chambers can vary from 20mm to much more than 400mm. At distances larger than 400mm, the opening angle of the two Rasnik lines is smaller and the resolution on the distance measurement is degraded (the four measurements of each Rasnik system become more correlated). We decided not to build a praxial sensor for larger distances in ATLAS³. Table 2 summarizes the requirements for each distance.

In 2002 we have successfully tested six praxial sensors (12 elements) in real conditions in a test beam experiment at CERN [7]. The other components of the ATLAS alignment were also tested. The global relative resolution of the full system was below $20\mu\text{m}$ which satisfies the requirements [8].

Since the beginning of April 2003, all mechanical pieces and all optical elements needed to produce the 2010 praxial elements are at Saclay (see Fig. 9). The production

³ For situations where two neighbouring chambers are further away (than 400mm), the alignment of the chambers is taken by other alignment sensors: projective and axial ones.

drawings of all ATLAS configurations are almost ready and the full production can start. The complete calibration phase will take 17 months.

Praxial type	Distance in-between praxial elements (mm)	Number of elements
D1	18	1644
D2	34	96
D3	52	96
D4	199	88
D5	245	16
D6	300	22
D7	388	48

Table 2: This table shows all working distances of the praxial sensors in the ATLAS experiment: from 18 to 388 mm. The total number of praxial elements is 2010. The last column indicates the number of elements for each distance (two elements make up one praxial). The magnification varies from 1 over 1.7 (D1) to 1 over 7.3 (D7).

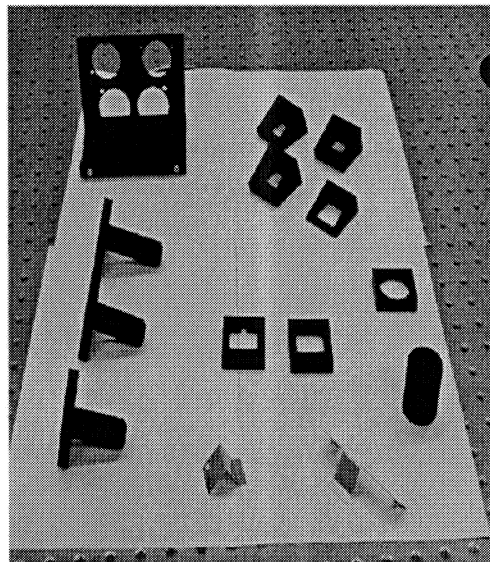

Fig. 9: This picture shows most of the mechanical pieces needed to build a praxial sensor. To ensure the quality of the assembly all elements are screwed and glued on the mechanical support (top left of this picture). The optical elements and their plastic covers are not shown. The assembly of the 2010 praxial elements has started in April 2003. The calibration of all praxial elements will take 17 months.

7) Conclusions

We have described in this paper the praxial optical alignment sensor and its use in the ATLAS experiment. We have shown how it can be calibrated and we give the final resolution which is of the order of $\pm 10\mu\text{m}$ and $\pm 100\mu\text{rad}$ for a range of $\pm 5\text{mm}$ and $\pm 5\text{mrad}$.

Finally, for the ATLAS experiment we need to produce 2010 elements i.e. 1005 praxial sensors. As already mentioned, due to particularities of the ATLAS layout, the praxial system is used for distances between two neighbouring chambers from 20mm to 400mm.

8) Acknowledgements

It is a pleasure to thank my Saclay colleagues and in particular V.Gautard and J.-P.Schuller as well as H. van der Graaf (Nikhef, Amsterdam) for fruitful discussions.

9) References

- [1] ATLAS Technical Proposal, CERN/LHCC/94-43, 15 December 1994, ATLAS Muon Spectrometer Technical Design Report, CERN/LHCC/97-22, 31 May 1997 and <http://atlasinfo.cern.ch:80/Atlas/Welcome.html>.
- [2] This drawing was made using the "PERSINT" software package. See M.Virchaux, D.Pomarede, "The PERSINT Manual", ATLAS-Soft-2001-003.
- [3] The Rasnik, H. Groenstege et al., ATLAS Muon Note 63 (1994), H.v.d. Graaf et al., Rasnik Technical System Description for ATLAS, ETR 2000-04, Sep. 2000.
See also: http://www.nikhef.nl/pub/departments/et/ccd_rasnik/ccd_rasnik.html.
- [4] J.-P.Schuller, private communication.
- [5] "PC based control system of a calibration bench for the ATLAS experiment", V.Gautard, O.Cloué, Frascati (Italie), 2002.
<http://www.lnf.infn.it/conference/pcapac2002/TALK/MO-P23/MO-P23.pdf>
- [6] « Résolution d'un système physique à 26 paramètres », V.Gautard, J.-P.Schuller, CANUM-2002, Anglet (France), 27 to 31 of May 2002, Eds. SMAI, Proc., (2002) 301. In French.
- [7] "System test of the ATLAS muon spectrometer in the H8 test area: program for year 2002", the ATLAS muon collaboration, ATLAS-Com-Muon-2002-007.
- [8] ATLAS-Muon-note on "2002-H8 test beam results", by the ATLAS H8-alignment group. Note in preparation.