

EUROPEAN ORGANIZATION FOR NUCLEAR RESEARCH

CERN - PS DIVISION

CERN/PS 2002-069 (RF)

DESIGN OF A 120 MEV H⁻ LINAC FOR CERN HIGH-INTENSITY APPLICATIONS

F. Gerigk^{*)}, M. Vretenar

Abstract

The SPL (Superconducting Proton Linac) study at CERN foresees the construction of a 2.2 GeV linac as a high beam-power driver for applications such as a second-generation radioactive ion beam facility or a neutrino superbeam. At the same time such a high-performance injector would both modernize and improve the LHC injection chain.

The 120 MeV normal-conducting section of the SPL could be used directly in a preliminary stage for H⁻ charge-exchange injection into the PS Booster. This would increase the proton flux to the CERN experiments while also improving the quality and reliability of the beams for the LHC. The 120 MeV linac consists of a front-end, a conventional Drift Tube Linac (DTL) to 40 MeV and a Cell Coupled Drift Tube Linac (CCDTL) to the full energy. All the RF structures will operate at 352 MHz, using klystrons and RF equipment recovered from the LEP collider. This paper concentrates on the design of the 3 to 120 MeV section. It introduces the design criteria for high-stability beam optics and the RF structure design work for the relatively low-frequency CCDTL. The advantages of this structure with respect to other solutions are outlined. The results of measurements on a cold CCDTL model are presented.

^{*)} RAL, Chilton, UK

XXI International Linear Accelerator Conference, 9-23 August 2002, Gyeongju (Kyongju), Korea

Geneva, Switzerland
16 September 2002

DESIGN OF A 120 MEV H⁻ LINAC FOR CERN HIGH-INTENSITY APPLICATIONS

F. Gerigk¹, M. Vretenar, CERN, Geneva, Switzerland

Abstract

The SPL (Superconducting Proton Linac) study at CERN foresees the construction of a 2.2 GeV linac as a high beam-power driver for applications such as a second-generation radioactive ion beam facility or a neutrino superbeam. At the same time such a high-performance injector would both modernize and improve the LHC injection chain.

The 120 MeV normal-conducting section of the SPL could be used directly in a preliminary stage for H⁻ charge-exchange injection into the PS Booster. This would increase the proton flux to the CERN experiments while also improving the quality and reliability of the beams for the LHC. The 120 MeV linac consists of a front-end, a conventional Drift Tube Linac (DTL) to 40 MeV and a Cell Coupled Drift Tube Linac (CCDTL) to the full energy. All the RF structures will operate at 352 MHz, using klystrons and RF equipment recovered from the LEP collider. This paper concentrates on the design of the 3 to 120 MeV section. It introduces the design criteria for high-stability beam optics and the RF structure design work for the relatively low-frequency CCDTL. The advantages of this structure with respect to other solutions are outlined. The results of measurements on a cold CCDTL model are presented.

1 HIGH-INTENSITY AT CERN - THE SPL

Increasing demand for higher performance of the proton beams has triggered a series of studies in the last few years that are still supported in spite of the recent decision to focus the quasi-totality of CERN resources on the LHC project. Considering only the currently approved physics programme plus the LHC experiments, a lack of protons can be foreseen from the LHC start-up. Moreover, the CERN neutrino and radioactive ion communities have ambitious plans that would address new fundamental physics and open the way for a vivid research programme at CERN between the LHC and a future linear collider but would introduce additional demands on the proton production complex. An improved injector complex would not only provide the new beams but also enhance the beam brightness, paving the way for an LHC upgrade.

Until now, the main emphasis has been on the design of the SPL (Superconducting Proton Linac), a 2.2 GeV H⁻ linac with 4 MW beam power. The SPL would inject high-brightness beams for the LHC into the CERN Proton Synchrotron (PS) as well as high-intensity beams for other users into an accumulator-compressor ring system located in the old ISR tunnel. The SPL could be built on the CERN site in a very cost-effective way by re-using RF equipment from the decommissioned LEP machine.

The SPL design has been analysed in detail [1], and recent refinements have led to a satisfactory conceptual design [2]. A cost analysis has confirmed the substantial savings obtained by using the LEP equipment.

However, the longer time scale for other projects due to the LHC delays and to its increased financial needs is now encouraging an intermediate solution, i.e. the construction in the medium term (2006/07) of only the room-temperature 120 MeV part of the SPL to become a new H⁻ injector for the PS Booster (PSB), replacing the aging 50 MeV proton injector. At present, CERN and Protvino are the only laboratories in the world still using high-current proton injection into a synchrotron instead of H⁻ [3]. A new higher-energy linac would increase the proton flux for the approved experiments as well as the beam brightness for the LHC. As a consequence of choosing the 352 MHz frequency, klystrons, circulators and waveguides from LEP could be re-used. Recent tests [2] indicate that the pulsed mode operation can be efficiently sustained by the originally CW LEP klystrons. Sufficient space and services for a new linac are available in the South Hall of the PS, where a transfer tunnel to the PSB already exists. Moreover, this linac would be a first step towards a full SPL and an essential test bench, with more relaxed parameters, for future higher-intensity projects. Table 1 presents the main beam parameters for the two configurations, PSB injector or SPL front-end.

Table 1: Beam parameters of the 120 MeV linac.

	Phase 1 (PSB)	Phase 2 (SPL)	
Maximum repetition rate	2	50	Hz
Source current	50	30	mA
RFQ current	40	21	mA
Chopper beam-on factor	75	62	%
Current after chopper	30	13	mA
Pulse length (max.)	0.5	2.8	ms
Average current	15	1820	μA
Max. beam duty cycle	0.1	14	%
Number of particles per pulse	0.9	2.3	· 10 ¹⁴
Transv. emittance (rms, norm.)	0.22	0.22	π mm mrad
Longitudinal emittance (rms)	0.18	0.18	π deg MeV
Maximum design current	30		μA

The H⁻ source and the RFQ section have been already considered [1, 2], while a significant effort is going towards the design of an adequate chopper line [4]. This paper deals in particular with the main part of this linac, the DTL and CCDTL section between 3 and 120 MeV.

¹ present address: RAL, Chilton, UK

2 DESIGN OF THE DTL-CCDTL SECTION

The section after the RFQ and chopper line uses a Drift Tube Linac (DTL) design. The standard Alvarez design is mandatory at 3 MeV, because only its short focusing period can provide sufficient focusing at this energy. However, at higher energy the possibility of lengthening the focusing period suggests the use of unconventional DTL designs, having the common feature of removing the quadrupoles from the drift tubes and placing them between short accelerating tanks. Such designs usually offer higher shunt impedance due to the lower drift tube capacitance, and lower structure cost due to the simpler drift tube construction and alignment. After an analysis of the different options, a Cell-Coupled Drift Tube Linac (CCDTL) design similar to the one developed at LANL [5] has been adopted from 40 MeV onwards. In this design the quadrupoles are “bridged” by coupling cells that connect adjacent DTL tanks each containing only a few drift tubes.

The simplified CCDTL approach studied at CERN and shown in Figure 1 can be effectively applied even at the relatively low frequency of 352 MHz. Each accelerating tank contains two or three drift tubes. A constant space of 250 mm is left between tanks for the quadrupole, the required $3/2 \beta\lambda$ distance between gaps being obtained by lengthening the nose cones on the tank cover. In this way all the coupling cells can be identical, considerably easing the tuning. The chains of accelerating tanks operate in the stable $\pi/2$ mode and a single feeder can be used from one 1 MW LEP klystron. Surface losses are low due to the relatively large dimensions (~ 0.5 m in diameter) and cooling is relatively easy. Moreover, the discontinuity in focusing period at transition (from $4 \beta\lambda$, FFDD for the DTL to $7 \beta\lambda$, FD for the CCDTL) is kept at a reasonable level.

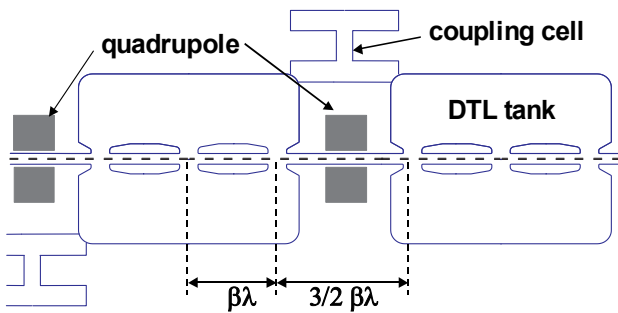

Figure 1: The CERN CCDTL concept

Finally, the main advantages of this CCDTL design as compared to a conventional DTL can be summarised as

follows:

- Quadrupoles outside of the RF and vacuum envelope are easier to cool, access, replace and align.
- Structure cost is lower, being based on the machining of short elements with relaxed tolerances.
- Shunt impedance is slightly higher (but real estate shunt impedance remains of the same order!).
- Stabilisation is easier to achieve with separated coupling cells than with post couplers.
- Focusing lattice is continuous (no intertank spacings), with less risks of longitudinal mismatch.

The final design [6] is shown in Figure 2 and the main parameters summarised in Table 2. Electromagnetic quadrupoles are used throughout the linac, which with respect to permanent magnetic quadrupoles present the advantage of being individually adjustable and exempt from loss of magnetisation by irradiation.

The DTL from 3 to 40 MeV consists of 3 Alvarez tanks. One klystron feeds the first tank, while tanks 2 and 3 are each fed by two klystrons. An FFDD focusing lattice has been preferred because it uses the given quadrupole strength more effectively than an FD lattice ($k_{Q, FFDD} \approx 1.4 k_{Q, FD}$) while only slightly increasing the beam size [6]. In the first tank a field (1.5–3 MV/m) and phase ramp ($-42^\circ \rightarrow -25^\circ$) is used to capture the bunches and to keep the longitudinal focusing forces approximately constant.

The CCDTL section is divided into two parts, the first with 3-gap accelerating tanks (1 chain of 6 tanks and 2 chains of 5 tanks) and the second with 4-gap tanks (6 chains of 3 tanks each). The aperture radius in the CCDTL is increased with respect to the DTL in order to keep the ratio between aperture and rms beam size at an almost constant level (between 7 and 8).

Table 2: Main parameters of the DTL-CCDTL linac

	DTL	CCDTL	
Input energy	3	40	MeV
Output energy	40	120	MeV
Number of tanks	3	37	
Number of klystrons	5	10	
Aperture radius	10	14-16	mm
Gradient E_0T	1.5-3	3	MV/m
Shunt impedance	21-40	40-23	MΩ/m
Focusing lattice	FFDD	FD	
Max. surface field	1.1	1.3	Kilpatrick
Cavity diameter	450	495	mm
Length	16.7	46.9	m
Number of quadrupoles	111	38	

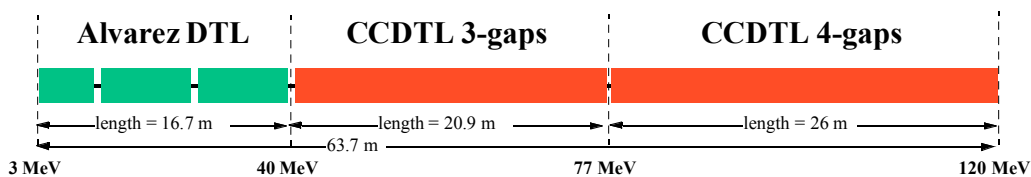

Figure 2: Layout of the 3 – 120 MeV linac section

3 BEAM DYNAMICS

The length of the focusing periods and the tunes in each plane are chosen to avoid particle lattice resonances ($\sigma_{Lr} < 90^\circ$) and emittance exchange between the planes [7]. A small transverse beam size is obtained by using a full current longitudinal to transverse tune ratio of < 0.8 , rather than using a possible stable area with higher tune ratios < 1.2 . For the proposed linac we found that strong initial mismatch (25-45%) using a gaussian input beam with twice the design current results in considerable beam loss (up to 350 W on a single spot for the SPL case) at four confined areas in the CCDTL. These losses can be reduced to 0.62 W, distributed on two spots, by scraping high amplitude particles (0.003% of the beam) at the beginning of the DTL and by increasing the quadrupole aperture radius in the CCDTL from 16 to 25 mm. Since transverse beam loss almost exclusively occurs in the quadrupoles, the bore radii of CCDTL cells can remain unchanged and therefore the RF efficiency also remains unchanged. We consider this feature as a major advantage of using a structure where the quadrupoles are separated from the RF.

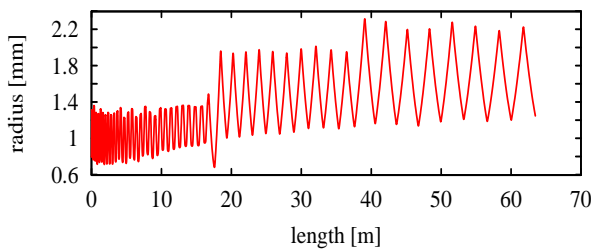

Figure 3: Rms beam radius along the DTL-CCDTL

4 RF AND MECHANICAL DESIGN

In order to study the RF properties of the CCDTL structure, a reduced scale (1:3) cold model of a chain of 12 two-gap accelerating tanks with 11 coupling cells has been built and tested (Figure 4). The goals were to test the 3D RF design codes, check the manufacturing tolerances, become familiar with the tuning procedure, close the stop band, and measure the sensitivity to errors of the field. After only a few rounds of tuning the stop band was easily closed. Figure 5 shows the measured dispersion curve and the electric field on axis. The coupling factor is 1.3 %.



Figure 4: The CCDTL cold model

The next step will be the construction of a hot model to validate the mechanical construction technique for the full scale structure and to analyse the thermal behaviour under

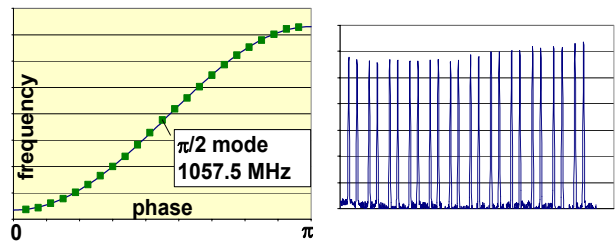

Figure 5: Measured dispersion curve (left) and on-axis field (right) of the CCDTL cold model.

RF power. The model is now in the final mechanical design stage. It will consist of two half accelerating cells connected by a coupling cell as shown in Figure 6. The peak RF power will be 120 kW, and the maximum design duty cycle is 20%. The model is made of copper plated stainless steel elements connected by Helicoflex joints. The cooling channels are partly welded partly machined into the steel. Power tests are foreseen from mid-2003 in a recently equipped 352 MHz test stand.

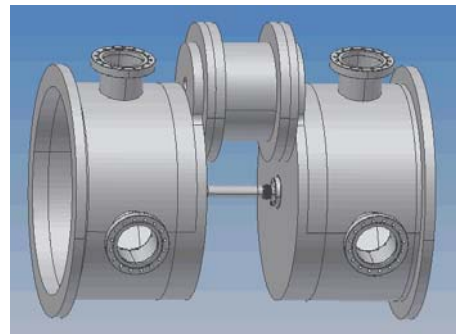

Figure 6: CCDTL hot model

5 ACKNOWLEDGEMENTS

We wish to thank for their support C. Völlinger and the EST/MT team: J. Genest, R. Chapman and Y. Cuvet.

6 REFERENCES

- [1] M. Vretenar (editor), Conceptual Design of the SPL, CERN 2000-012.
- [2] K. Bongardt, F. Caspers, H. Frischholz, R. Garoby, F. Gerigk, A.M. Lombardi, R. Losito, A. Mostacci, M. Paoluzzi, J. Tückmantel, M. Vretenar, Progress in the Design of the SPL, an H^- High-Intensity Linac at CERN, EPAC 2002, Paris.
- [3] J. Clendenin, L. Rinolfi, K. Takata, D. Warner (eds.), Compendium of Scientific Linacs, CERN/PS 96-32.
- [4] F. Caspers, K. Hanke, A. Lombardi, A. Millich, A. Mostacci, M. Paoluzzi, M. Vretenar, Design of a Chopper Line for the CERN SPL, this conference.
- [5] J. Billen, F. Krawczyk, R. Wood, L. Young., A New RF Structure for Intermediate-Velocity Particles, Linac 94, Tsukuba.
- [6] F. Gerigk, M. Vretenar, Design Choices for the SPL Normal-Conducting Front End (3-120 MeV), PS/RF Note 2002-038, NF Note 110.
- [7] F. Gerigk, I. Hofmann, Beam Dynamics of Non-Equipartitioned Beams in Case of the SPL Project at CERN, PAC 01, Chicago.