

# OPERATIONAL CHARACTERISTICS, PARAMETERS, AND HISTORY OF A (13T) Nb<sub>3</sub>Sn DIPOLE\*

R. Benjegerdes, P. Bish, S. Caspi, K. Chow, D. Dietderich, R. Hannaford, W. Harnden, H. Higley, A. Lietzke, A. McInturff<sup>†</sup>, L. Morrison, M. Morrison, R. Scanlan, J. Smithwick, and C. Taylor  
Lawrence Berkeley National Laboratory, Berkeley, California 94720

*Abstract*

The early design and test results have been previously reported. [1] During the subsequent operation of “D20” the accelerator prototype dipole has provided both additional and more detailed data as to its characteristics and performance. D20’s use as a test facility for high field critical current measurements [2] has provided operational experience and history pertaining to accelerator required characteristics. There has been recently obtained data related to field quality, operational reproducibility and reliability, which will be presented. This prototype “D20” has attained the highest magnetic field of any accelerator prototype dipole constructed and tested to date. The magnet has continued to operate routinely.

D20 is a four layer graded cable cosine  $\Theta$  winding distribution 50mm bore 1meter long dipole. The inner two layers (1&2) used one size and the outer two layers (3&4) another. The coils are double layers of Nb<sub>3</sub>Sn/Cu “Rutherford” cable wound, reacted, fiberglass insulated and fully epoxy impregnated. In Table 1 the inner cable design current densities and currents are compared to the measured cable and strand value.[4] The magnet’s operational and peak performance current densities achieved at 4.4K are given as well. These data are compared at the position where the critical current at the local stress level are reached as either measured by the cable I<sub>c</sub>(strain, H) or the strand extrapolated by using the percentage reduction seen by cables made from it. There were strands of two different geometries used and their sensitivity to transverse strain was different by a factor

## 1 INTRODUCTION

D20 was designed as a “proof of principle” demonstration that a high field >10T accelerator type dipole could be constructed from brittle superconductor (A-15, hi-T<sub>c</sub>, etc) and operate in the range above ten tesla. The magnet design parameters [3] and its early test data have been reported.[1] There was a concern at that time that a serious performance limit had arisen from possible conductor degradation. There were a number of erratic quenches occurring in the Nb<sub>3</sub>Sn conductor near a Nb<sub>3</sub>Sn /NbTi splice box. These events were occurring at lower and lower fields (~11T(4.4K)). It had been previously decided to use D20 as a facility to provide high fields for long straight cable critical current “I<sub>c</sub>” measurements. In the course of obtaining the Nb<sub>3</sub>Al “I<sub>c</sub>” data, the magnet was cycled to fields ~12.5T(4.5K) without incident. There has been a re-examination of the early data. These checks have discovered some data filtering problems as well as a few calibrations that needed to be updated. The subsequent analysis results and those corrected data are reported at this time as well.

Table 1: Currents/turn, Current Densities, and Fields

	Amp/turn (kilo-amp)	A/mm <sup>2</sup> ( overall)	Central Field (T)
Design (140MPa) [measured]	6400	276	13 [12.96]
IGC cable meas.[4] (~95MPa) I <sub>c</sub>	6320	273	12.82
TWA cable meas.[4] (~95MPa) I <sub>c</sub>	6618	285	13.44
IGC strand meas. (~95MPa) I <sub>c</sub>	6820	294	13.7
TWA strand meas. (~95MPa) I <sub>c</sub>	6904	298	13.84
D20 operating at 4.4K	6303	272	12.78
D20 normal operation at 4.4K	6109	263	12.44

<sup>†</sup>This is the critical peak field/strain point value

of six at 100MPa (3.7% vrs. 23%). These results lead to the conclusion that the mechanism operating here is extrinsic and can be designed for a minimum impact. The two manufacturers of the two types of strand were Intermagnetics General Corporation (IGC) and Teledyne Wah Chang (TWCA). The magnet has not spontaneously quenched in the critical peak field/strain location as of yet. The coil’s end, pole, azimuthial, and axial spacers were made from Al-bronze. The bronze was reasonably matched the windings thermo-mechanical properties. The double layered coils were assembled with the appropriate shimming and placed in a bronze sleeve. The assembly was then placed inside the iron yoke pieces on the straight sections and stainless steel(ss) on either end. The coil assembly with bronze sleeve and longitudinally bolted yokes was covered by a split thin ss bobbin and 18 layers of tensioned rectangular ss wire was wound in it to

## 2 DESIGN & OPERATIONAL PARAMETERS

<sup>†</sup>Email: admcinturff@lbl.gov

\*The work is supported under contract # DE-AD03-76SF00098 by Director, Office of Energy Research, Office of High Energy Physics, US Dept. of Energy.

preload the coils to ~100 and ~65 MPa, inner and outer layer respectively. Next, a set of iron end plates were bolted on and an outer ss skin was welded to them. The end bullets were then torqued in stages to axially compress the coil up to 820 kN. The assembly of D20 is shown in Figure 1 with the location of instrumentation. The windings were actively protected by 25µm thick ss

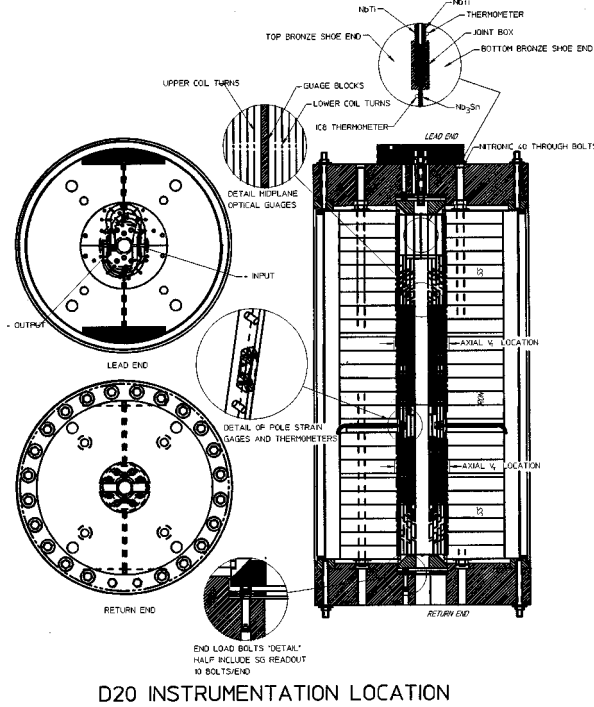

Figure 1: D20 Assembly

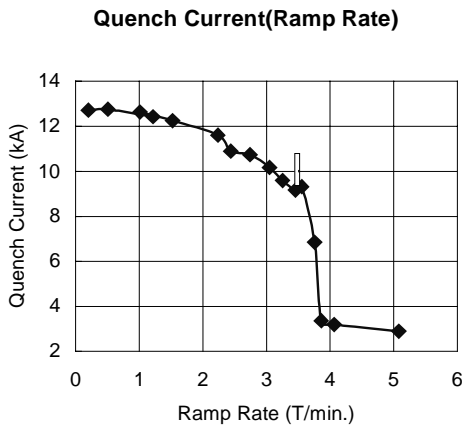

Figure 2: Quench current at 4.4K versus ramp rate

heaters which covered >80% of the turns, and were located next to each layer in a ss/Kapton laminate with the voltage tap traces. The protection heaters routinely operated at a surface power density of 75 and 27 w/cm<sup>2</sup> for inner and outer layers respectively. The highest average winding temperatures after quench were in the outer layers (between 165K-185K). When the quench

originated in an outer turn, the highest hot spot estimate was 234K. By comparison, the inner two layers averaged 80K - 120K and if it originated there the highest temperature estimate was 152K. The maximum number of Miits (Million-ampere<sup>2</sup>-seconds) absorbed during a quench during the test was 4.3. The Miits of the 4.4K quenches increase almost linearly from 3 to 4 from fields of 10 to 12.8T. In super fluid helium Miits vary from 3.8 to 4.3 from 12 to 13.1 and dropped back to 4.1 by 13.5T. The quench history as a function of ramp rate with an open bore filled with LHe at 4.4K is given in Figure 2. During the Nb<sub>3</sub>Al “I<sub>c</sub>” test, it was found that the knee of the curve had moved from 1T/min to about half that value. This was attributed to the restriction of LHe in the magnet aperture. The magnet tolerated the modest heat input from the Nb<sub>3</sub>Al cable sample being driven normal in the aperture conducting a few kiloamperes at magnetic fields up to ~12.5T.

### 3 HISTORY

There have been three full cool down cycles from room to LHe temperature of D20 to date. Each of these cycles was to change the aperture configuration therefore requiring the cryostat to be partially disassembled and reassembled. In order to measure the harmonic content of the aperture field; there had to be an anti-cryostat installed and aligned in the bore of D20. Once this was accomplished a high speed “Morgan Coil” was inserted and harmonic data obtained. The time constant for the sextupole decay from ramped values to dc at fields >1T was ~1.5min. Table 2 gives dc values of the Fourier Coefficients normalized at 1cm at 2.5T as measured by the rotating “Morgan Coil”. The dc harmonics measured

Table 2: D20 Harmonics at 2.5T(I=1086A)

NΘ	Desig n	Meas.	Units
2Θ	-0.0	-1.5 <sup>+</sup> ±0.8	x10 <sup>-4</sup> cm <sup>-1</sup>
3Θ	-0.8	-3.8±1.6	x10 <sup>-4</sup> cm <sup>-2</sup>
4Θ	0.0	< 1.2 ±1.2	x10 <sup>-4</sup> cm <sup>-3</sup>
5Θ	0.0	-0.8±0.5	x10 <sup>-4</sup> cm <sup>-4</sup>

<sup>+</sup> out of phase.

are on the order of the design values with the exception of the quadrupole term. The quadrupole term however was expected due to the size difference of the double layer inner coils, top compared to the bottom. The width of the sextupole dc hysteresis curve at 1.5T is 6.5units and at 9T <1unit. At a ramp rate of 1T/min, the width of the sextupole hysteresis curve at 9T is 5units as analyzed by the tangential/bucked coil system. [5] The transfer function varies from 23.5 g/amp at 2T to 21.7 g/amp at 10T. The third full thermal cycle occurred in order to

install the 1m long “short cable” sample mount and the Nb<sub>3</sub>Al cable in order to measure the critical currents from 10T to 12.5T at 4.4K. The sample joints were made to the copper return leg in the low field regions between the magnet winding ends and the iron end plates. (Figure 1) D20 was quenched a few times until the increased sensitivity to ramp rate was appreciated when the bore is not full of liquid helium. This sensitivity had been present on the second cool down but had not been recognized. There were problems with the co-axial power leads quenching the current joints of the sample. This situation resulted in quite a bit of heat being generated in the aperture during the measurements. However unlike the second full thermal cycle where quench performance had been at best erratic; D20 returned to fields of ~12.5T without quenching other than the ramp rate driven type early in the test. (Figure 3) The problematic area of the magnet (i.e. the outer layer coil lead between the magnet and just before the Nb<sub>3</sub>Sn/NbTi splice and splice box) appears to be stable at this time. There are several unique features about this particular area in this particular coil as was noted earlier [1] and the presence of a thick Kapton shim (254µm) additionally locally reduces the modulus.

### 4 CONCLUSIONS & DISCUSSION

It appears that D20 has not been degraded (or at least appears not to be presently limited in quench current by conductor damage) by the 60<sup>+</sup> spontaneous quenches and the 60<sup>+</sup> experimentally initiated quenches. In Table 3 the 4K maximum current densities and design values are given. The outer cable has been quenched with a copper stabilizer current density “J” of 1535 amps/mm<sup>2</sup> in Super Fluid helium. D20 has routinely operated at currents that in the advent of a quench; the “J(Cu)” would be 1400 amps/mm<sup>2</sup>. To date, the maximum temperature during 4.4K operation measured in the windings after a quench

have been in the 100K to 200K range, which appears moderate. During the experiments using the inner protection heaters to measure the wattage margin of the inner windings,[1] it became apparent that the magnet was protected by the outer winding protection heater sets(4)

Table 3: Current Densities

D20 @ 13T 6420A @4.2K	Inner Cable IGC @ 4.4K		Outer Cable TWCA @ 4.4K	
	Design	Reached	Design	Reached
J <sub>m</sub> (A/mm <sup>2</sup> )	1302	1282	1462	1440
J <sub>sp.cu</sub> (A/mm <sup>2</sup> )	559	551	1550	1527

alone with less than a 50K increase. It is not clear at this time that this is true for the inner layer sets(4) as well. It has been decided to mount “D20” in a vertical dewar in order to decrease the turn-around-time for its use as a short sample facility.

### REFERENCES

- [1] A. McInturff, et. al. “Test Results for a high field (13 T) Nb<sub>3</sub>Sn Dipole”, 1997 PAC Proceedings, Vancouver, B.C., pp. 3212-3214.
- [2] M. Wake, et. al., “Insertion Nb3Sn coils for Magnet Development”, to be published in proceedings of Magnet Technology conference MT-15 Beijing, China.
- [3] D. Dell’Orco, et. al., “Design of the Nb<sub>3</sub>Sn Dipole D20”, IEEE Trans. On Appl. Superconductivity, 3 #1 March 1993, pp. 82-86.
- [4] D. Dietderich, et. al., “Critical Current of Superconducting Rutherford cable in High Magnetic Fields with Transverse Pressure”, to be published in the proceedings ASC’98, Palm Desert, CA, 14-18 Sept. 1998.
- [5] S. Caspi, et. al., “Development of High Field Dipole Magnets for Future Accelerators”, to be published in the proceedings of Magnet Technology Conference, MT15, Beijing, China, Oct. 20-24, 1997.

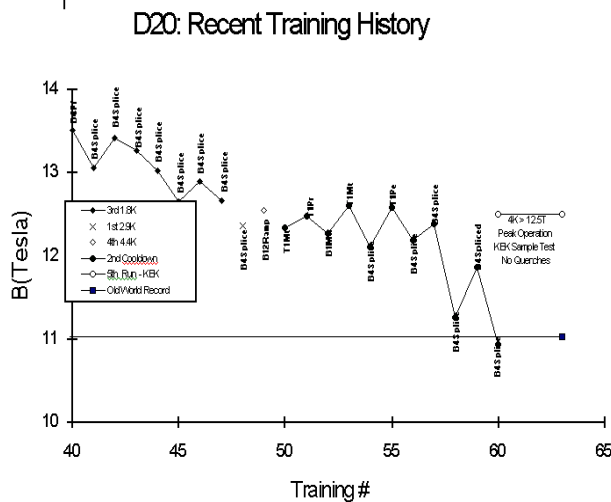

Figure 3: Recent Training History at 4.4K