

# Orientifold dual for stuck NS5 branes

---

**Bo Feng, Yang-Hui He, Andreas Karch**

*Center for Theoretical Physics, MIT*

*Cambridge, MA 02139, USA*

*E-mail: yhe@grendel.mit.edu, fengb@ctp.mit.edu, karch@ctp.mit.edu*

**Angel M. Uranga**

*TH Division, CERN*

*CH-1211 Geneve 23, Switzerland*

*E-mail: Angel.Uranga@cern.ch*

**ABSTRACT:** We establish T-duality between NS5 branes stuck on an orientifold 8-plane in type I' and an orientifold construction in type IIB with D7 branes intersecting at angles. Two applications are discussed. For one we obtain new brane constructions, realizing field theories with gauge group a product of symplectic factors, giving rise to a large new class of conformal  $\mathcal{N} = 1$  theories embedded in string theory. Second, by studying a D2 brane probe in the type I' background, we get some information on the still elusive (0,4) linear sigma model describing a perturbative heterotic string on an ADE singularity.

**KEYWORDS:** D-branes, String Duality, Brane Dynamics in Gauge Theories.

---

## Contents

<b>1. Introduction</b>	<b>1</b>
<b>2. The type I' background and T-duality to type I</b>	<b>3</b>
2.1 T-duality along the interval direction	3
2.2 SO(32) strings on a smooth ALE	4
<b>3. A new T-duality into a orientifold with branes at angles</b>	<b>5</b>
3.1 A non-compact orientifold with branes at angles	5
3.2 The closed string spectrum and the worldvolume theory on the 7-branes	7
3.2.1 The closed string spectrum	7
3.2.2 The worldvolume theory on the D7 branes	7
3.3 Closed string — open string duality	11
3.4 Tadpoles	13
<b>4. New brane constructions of 4d <math>\mathcal{N} = 1</math> theories</b>	<b>14</b>
4.1 The brane and field theory calculations	14
4.2 The spectrum from the orientifold calculation	17
<b>5. The heterotic string on an ADE singularity</b>	<b>18</b>
5.1 The problem	18
5.2 Using the new T-duality	20

---

## 1. Introduction

Supersymmetric gauge theories can be embedded into string theory via intersecting branes and branes ending on branes, following the pioneering work of [1]. This approach proved powerful in predicting moduli spaces, global symmetries and dualities of the theories engineered that way. Even these days, now that with the advent of AdS/CFT duality we have more refined tools to actually study dynamics, brane setups are still quite popular to help getting intuitive pictures. This is facilitated by the fact that many brane setups can be related by T-duality to branes moving on a singular geometry. In particular, dualization into orbifold and orientifold backgrounds proves useful, since this way one can employ perturbative string techniques to calculate and derive the rules governing the brane setup. These T-dualities follow from the duality between Kaluza-Klein monopoles and NS5 branes [2]. In [3, 4] it

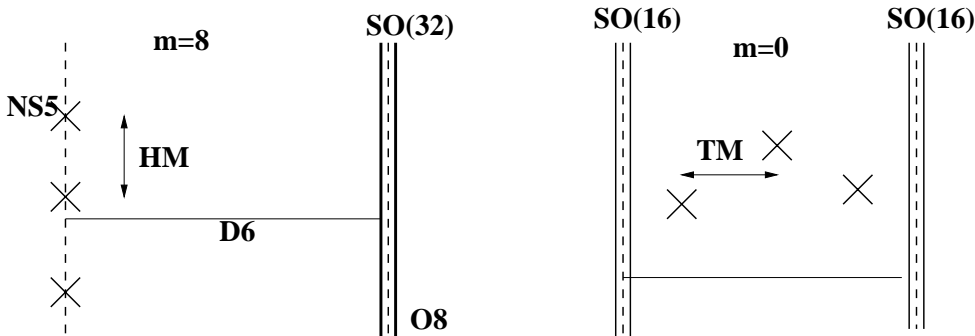

**Figure 1:** Examples of the two different phases in the type I' setup. Tensor multiplets correspond to motion on the compact 6 interval, hyper-multiplets to motion in the transverse 789 space. The  $m$  referred to the cosmological constant set up in the bulk.

was first used to relate 6d Hanany-Witten (HW) setups to D5 branes on orbifold singularities. Similar relations were found for  $\mathcal{N} = 2$  theories in 4d [5, 6], D-brane probes of the conifold [7, 8] and other CY singularities [9, 10].

In this paper we will study T-duality relations for NS5 branes in type I' theory. The building blocks are the NS5 branes along 012345, the defining orientifold O8 planes and the corresponding D8 branes along 012345789. In addition one may introduce D6 branes along 0123456, that is, stretching along the direction 6 which is taken to be a compact interval. This is the background geometry and it preserves 8 supercharges. On this background we are going to consider various probes preserving 4 supercharges, in particular a D2 brane along 016 or a D4 brane along 01237.

The low energy dynamics of the background is described by an  $\mathcal{N} = (1, 0)$  gauge theory in 6 dimensions. There are two different phases, shown in figure 1: the NS5 branes can either be free to move in pairs in the bulk, their 6 position being the scalar in a tensor multiplet, or they can be stuck on one of the O8 planes, with positions encoded in the scalars of hypermultiplets. Taking the direction 6 compact, the former setup is easily T-dualized along it into a type IIB orientifold on an ALE space.<sup>1</sup> of the kind studied in [11]–[16]. In this T-dual orientifold picture the spectrum and interactions on the branes can be reliably calculated. Due to the extra tensor multiplets, it is well known that this setup does not correspond to a perturbative compactification of ten-dimensional type I theory. In the S-dual heterotic SO(32) theory, we are describing a non-perturbative phase with small instantons (T dual to the D6 branes) on an ALE singularity (T dual to the NS5 branes). The requirement that the NS5 branes are moving in pairs translates into the statement that some of the singularities are frozen and cannot be blown up (for every NS5 brane pair we are always left with at least an  $A_1$  singularity).

<sup>1</sup>More precisely, on a Taub-NUT (TN) space. The field theory data, however, depend only on the geometry near the centers, which can be approximated by an ALE geometry.

The other phase is when the NS5 branes are stuck on the orientifold, as studied in [17]. This of course can still be T-dualized in the same way, however the T-dual is no longer a free orbifold conformal field theory, so we no longer have a perturbative description. In this phase all the tensors are frozen while all the NS5 branes can move independently, hence it describes type I on the ALE space. However we are no longer presented with a calculational tool to construct the spectrum on the probe branes.

We will present another T-duality, along the 7 direction, that transforms the setup with the stuck NS5 branes into a perturbative orientifold of IIB with O7 planes and D7 branes intersecting at angles. This is a non-compact version of the models introduced in [18]. As an application and check we will consider introducing D2 brane and D4 brane probes in this background. The D4 brane realizes a new class of  $\mathcal{N} = 1$  theories in four dimensions, including several conformal examples. The D2 brane corresponds to a D1 brane probe in type I theory on an ALE singularity, hence our construction provides some information on the so far elusive (0,4) LSM [19] describing the heterotic string on an ALE space or, once we include the D6 branes, on the ADHM constructions of SO(32) instantons on an ALE space.

In the next section we will review the type I' background, describe the T-duality along the 6 direction and review the problems associated with stuck NS5 branes. In section 3 we introduce the orientifold construction and give evidence that it is indeed the T-dual after dualizing along 7. In the following two sections 4 and 5 we then present as applications and checks the theory on the D4 brane probe and the D2 brane probe.

## 2. The type I' background and T-duality to type I

### 2.1 T-duality along the interval direction

We start by reviewing the T-duality of type I' theory with O8 planes (along 012345789), NS5 branes (along 012345), and D6 branes (spanning 0123456) along the compact 6 interval, as described in the introduction. First let us discuss the case that corresponds to a perturbative orientifold of type IIB on an ALE space, of the kind discussed in [11]–[16]. In the type I' dual the NS5 branes are out in the bulk, half the hypers (corresponding to 789 positions) are frozen and we have extra tensors from the 6 position of the NS5 branes [3, 4]. Turning on Wilson lines on the IIB side<sup>2</sup> maps in type I' to moving the D8 branes into the bulk. For a  $\mathbb{Z}_k$  singularity with odd  $k$  on the IIB side, one NS5 brane is stuck on an O8 plane and the others move in the bulk in pairs. For even  $k$ , we can have  $k/2$  pairs or one NS5 brane stuck at each

---

<sup>2</sup>More accurately, turning on asymptotically flat self-dual gauge backgrounds in the Taub-NUT geometry. We denote the asymptotic connections by ‘Wilson lines’, and point out that in the ALE limit they correspond to choices of D brane Chan-Paton factors for the orbifold group.

of the O8 planes and the rest moving in pairs. The stuck NS5 branes correspond to monopoles living in the D8 gauge group [17]. In the literature, e.g. [16], latter models are often referred to as ‘without vector structure’.

Of course this IIB orientifold is not type I on the ALE space. In order to obtain type I we have to mod out by world-sheet parity  $\Omega$ . The action  $\Omega$  reverses the sign of the NS-NS B-field, and hence is a symmetry of type IIB string theory only if all the NS-NS B-fields are turned off. Since in the free world-sheet orbifold CFT of type IIB on ALE space the twisted sector NS-NS B-fields are non-zero, in this theory  $\Omega$  can not be gauged. Instead we would have to orientifold the interacting ALE conformal field theory at  $B = 0$ .

In the perturbative orientifolds with non-zero B-fields of [11, 12, 13, 16]  $\Omega$  is combined with a space-time action [20] exchanging oppositely twisted sectors. The resulting models involve tensor multiplets and correspond to new phases of the heterotic string. The only example without extra tensors (the orientifold of  $\mathbb{C}^2/\mathbb{Z}_2$  in [11, 12, 13]) corresponds to a bundle without vector structure [21], which hence also describes a compactification of the SO(32) string with a non-trivial gauge background turned on. In type I’ the corresponding configuration has one NS5 brane stuck at each O8 plane.

Unless we turn Wilson lines to the  $SO(16) \times SO(16)$  point, additional D6 branes are required in the bulk, due to charge conservation in the background of the non-trivial cosmological constant [3, 4]. We are always free to add an arbitrary equal number of D6-branes on each interval, corresponding to adding small instantons (that is D5 branes) on the IIB side.

## 2.2 SO(32) strings on a smooth ALE

In order to study the heterotic string with a trivial bundle on an ALE, we have to mod out IIB just by  $\Omega$  (without geometric action) and study the D-string in this background. As argued above, we would have to orientifold the theory at  $B = 0$ . Let us once more analyze the T-dual type I’ language. Since in this phase the twisted sector tensors are projected out, the NS5 branes must be stuck on the orientifold planes, with their positions within the O8 plane parametrized by scalars in the hypermultiplets. If we realize the SO(32) by putting all D8 branes on (say) the right O8, in order to have a trivial bundle we should locate all the NS5 branes at the left O8 plane. Having all the D8 branes on one side sets up a cosmological constant in the bulk. A NS5 brane in such a background cosmological constant would have to be connected with 8 D6 branes to the right O8 plane. So without extra (fractional) small instantons present (D6 branes along 0123456), the bulk cosmological constant does not allow the NS5 branes to wander off into the bulk. There is no phase transition trading hypermultiplets for tensors [17]. For a generic choice of Wilson lines, the NS5 branes are stuck in a similar fashion on the less occupied O8 plane. They can be interpreted as monopoles

of the D8 brane world-volume gauge theory. Only at the  $SO(16) \times SO(16)$  point NS5 branes may move around freely, since the bulk cosmological constant vanishes.

We will show that in order to describe the phase with stuck NS branes, another T-duality can be employed. In the type I' language this is a duality along the direction 7. This duality can be established when we take the 6 direction to be non-compact, that is we study a single O8 with the stuck NS5 branes, while compactifying the 7 direction. So this is not really the T-dual of the situation we want to study, with 7 non-compact and 6 compact. However when interested in the gauge theory on a probe, all the interesting dynamics are determined locally by the interplay of probe branes and orientifold and NS5 branes. The new T-duality gives us a calculational tool to describe a single O8 plane with an arbitrary number of D8 branes and stuck NS5 branes, and probes on this background.

### 3. A new T-duality into a orientifold with branes at angles

#### 3.1 A non-compact orientifold with branes at angles

According to [2],  $k$  NS5 branes on a circle are T-dual to an ALF space with a  $\mathbb{C}^2/\mathbb{Z}_k$  singularity at the origin. Positions of the NS5 brane in the transverse space map to the 3 blowup parameters associated with each of the  $(k-1)$  homologically non-trivial 2-spheres, and positions along the compact direction map to the NSNS 2-form field fluxes through the spheres. Note that having the NS5 branes stuck on the O8 freezes one of the 3 blowup modes (the 6 position). Instead we have a 10 position on the M-theory circle, which corresponds to a RR 2-form flux in the IIB orientifold.

In our configuration of figure 1, considering the direction 7 compact and T-dualizing along it, the T-dual is an  $k$ -center Taub-NUT (TN) space, with the circle fiber parametrized by  $7'$ , the T-dual of the 7 direction, and the base parametrized by 689. Our purpose is to identify the geometry of the T-dual of the type I' O8/D8 system. The original O8 planes and D8 branes were wrapped in the 7 direction, hence they should correspond to D7 branes not wrapped on the circle fiber of TN. In a suitable complex structure, the TN can be described by the hypersurface in  $\mathbb{C}^3$

$$UV = Z^k, \tag{3.1}$$

and the circle corresponds to the  $U(1)$  orbit  $(U, V) \rightarrow (e^{i\lambda}U, e^{-i\lambda}V)$ , with real  $\lambda$  ranging from 0 to  $2\pi$ . Near the core of the TN space, the geometry is locally that of a  $\mathbb{C}^2/\mathbb{Z}_k$  singularity, with the generator  $\Theta$  of  $\mathbb{Z}_k$  acting as

$$\Theta : \begin{cases} z_1 \rightarrow e^{2\pi i/k} z_1 \\ z_2 \rightarrow e^{-2\pi i/k} z_2, \end{cases}, \tag{3.2}$$

where one can take e.g.  $z_1 := x^6 + ix^8$  and  $z_2 := x_7 + ix_9$ . These coordinates are related to the above ones by  $U = z_1^k, V = z_2^k, Z = z_1 z_2$ .

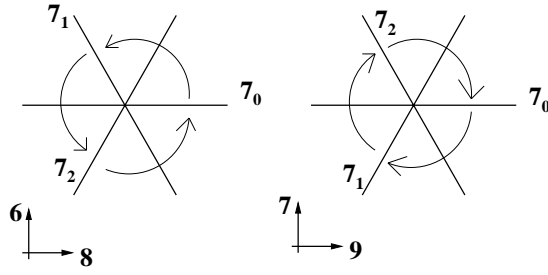

**Figure 2:** On the covering space the orbifold action acts on the branes/planes by rotation. Including all the mirror images under the orbifold action, we are required to include branes intersecting at angles.

So in order to T-dualize the O8 plane we are looking for an orientifold action in the Taub-NUT geometry, with sets of fixed points (O planes) not wrapping the  $S^1$  fiber. An action with the correct properties is given by  $\Omega R(-)^{FL}$ , where  $\Omega$  is world-sheet parity, and  $R$  is the spacetime action

$$R : \begin{cases} z_1 \rightarrow \bar{z}_1 \\ z_2 \rightarrow \bar{z}_2 \end{cases} . \quad (3.3)$$

The fixed set of  $R$  is  $z_1 = \bar{z}_1, z_2 = \bar{z}_2$ , which is a special lagrangian cycle. Hence the corresponding O7 plane preserves the correct number of supersymmetries. Notice that the full orientifold group contains different elements  $\Omega R \Theta^a$ , whose sets of fixed points lead to a set of  $k$  O7 planes at angles, as shown in figure 2. Specifically, the curves wrapped by the O7 planes are given by

$$z_1 = e^{-2\pi i \frac{a}{k}} \bar{z}_1 \quad ; \quad z_2 = e^{2\pi i \frac{a}{k}} \bar{z}_2. \quad (3.4)$$

with  $a = 0, \dots, k-1$ . These orbifold and orientifold actions have been considered in [18], in the context of compact toroidal orbifolds.

Clearly, the T-duals of the D8 branes correspond to  $\mathbb{Z}_k$  invariant sets of D7 branes at angles wrapped on curves of the type described, see figure 2. To see this, for example, if we start with a D7 brane wrapped on  $z_1 = \bar{z}_1, z_2 = \bar{z}_2$ , after the action of  $\Theta^b$  we get a D7 brane wrapped on  $e^{i \frac{2\pi b}{k}} z_1 = e^{-i \frac{2\pi b}{k}} \bar{z}_1$  and  $e^{-i \frac{2\pi b}{k}} z_2 = e^{i \frac{2\pi b}{k}} \bar{z}_1$ . Rewriting this we have  $z_1 = e^{-i \frac{4\pi b}{k}} \bar{z}_1$  and  $z_2 = e^{i \frac{4\pi b}{k}} \bar{z}_1$ , which is a curve of the kind in (3.4) for  $a = 2b$ . Furthermore, this calculation shows that there is a difference between the  $k$  odd case and  $k$  even case. For odd  $k$  a  $\mathbb{Z}_k$  invariant configuration of D7 branes is given by  $k$  sets of D7 branes wrapped on the curves above. For even  $k$ , however,  $\mathbb{Z}_k$  does not relate curves with even and odd  $a$ . Hence it is possible to construct  $\mathbb{Z}_k$  invariant combinations of D7 branes with only  $P = k/2$  sets, related by  $\mathbb{Z}_P$ , and the orbifold action contains an additional  $\mathbb{Z}_2$  acting within each stack. Even though there is no inconsistency in such possibilities, we will be interested in configurations with local charge cancellation (see section 3.4). Such configurations

involve  $k$  sets of D7 branes on the  $k$  curves above, namely two  $\mathbb{Z}_k$  invariant sets of D7 branes, wrapped on the even and odd  $a$  curves, respectively.

A similar construction can be made for orbifold CY 3-folds. In this case the branes will wrap special lagrangian 3-cycles. Compact versions of such models have appeared in [22, 23]. Non-compact orbifolds with branes at angles (in the absence of orientifold projection) have been considered in [24].

### 3.2 The closed string spectrum and the worldvolume theory on the 7-branes

#### 3.2.1 The closed string spectrum

Besides the usual matter from the untwisted sector, the closed string twisted sectors contain, before the orientifold projection,  $k - 1$  hyper and tensor multiplets of 6d  $(1, 0)$  susy. The orientifold projection above maps each twisted sector to itself, and can be seen to project out the tensor multiplets, leading to  $k - 1$  hypermultiplets, in agreement with the result in the type I' construction. This result generalizes to arbitrary  $\mathbb{Z}_k$  the closed string spectrum for crystallographic twists in [18].

An alternative derivation is to follow the analysis of [25], which deals with the related orientifold action  $\Omega R'$  with  $R' : (z'_1, z'_2) \rightarrow (z'_2, -z'_1)$ , and leads to  $k - 1$  tensor multiplets and no hypermultiplets. This is similar to our action  $R$  if we rewrite  $R$  by expressing the same ALE in a different preferred complex structure, by defining  $z'_1 = z_1 + \bar{z}_2, z'_2 = z_2 + \bar{z}_1$ , where we have  $R : (z'_1, z'_2) \rightarrow (z'_2, z'_1)$ . This differs from  $R'$  in just one sign, which can be seen to flip the orientifold action in the twisted sectors to yield  $k - 1$  hypermultiplets and no tensors.

#### 3.2.2 The worldvolume theory on the D7 branes

In order to calculate the worldvolume theory we have to specify the  $\mathbb{Z}_k$  action on the D7 brane indices. Starting with the odd  $k$  case, and labeling the  $k$  stacks of  $n$  D7-branes by a Chan-Paton index  $a = 1, \dots, k$ , the action of the generator  $\Theta$  of  $\mathbb{Z}_k$  is to map the  $a^{th}$  to the  $(a + 1)^{th}$  stack. Hence we have

$$\gamma_{\Theta,7} = \begin{pmatrix} \mathbf{1}_n & & & \\ & \mathbf{1}_n & & \\ & & \dots & \\ & & & \mathbf{1}_n \\ \mathbf{1}_n & & & \end{pmatrix} \tag{3.5}$$

which we write as  $(\gamma_{\Theta,7})_{ab} = \delta_{b,a+1} \mathbf{1}_n$ . Notice that upon diagonalization, this matrix is equivalent to the more familiar

$$\gamma_{\Theta,7} = \text{diag}(\mathbf{1}_n, \omega \mathbf{1}_n, \dots, \omega^{k-1} \mathbf{1}_n), \tag{3.6}$$

where  $\omega = e^{2\pi i/k}$ . However, working on the basis in (3.5) is more convenient.



The orientifold projection is represented by the matrices

$$\gamma_{\Omega R,7} = \text{diag}(A_n, \dots, A_n) \quad (3.7)$$

with

$$A_n = \mathbf{1}_N \quad (3.8)$$

or

$$A_n = \begin{pmatrix} 0 & \mathbf{1}_{n/2} \\ -\mathbf{1}_{n/2} & 0 \end{pmatrix} \quad (3.9)$$

corresponding to the choice of  $O8^+$  or  $O8^-$  plane on the T-dual side respectively.

For even  $k = 2P$ , we consider configurations with two  $\mathbb{Z}_k$  invariant set (a total of  $k$  stacks), which we treat independently. Each contains  $P$  stacks of  $n$  D7-branes, labeled by  $a = 1, \dots, P$ . The  $\mathbb{Z}_k$  action is represented by the  $P \times P$  block matrix

$$\gamma_{\Theta,7} = \begin{pmatrix} M_n & & & \\ & M_n & & \\ & & \dots & \\ & & & M_n \\ M_n & & & \end{pmatrix} \quad \text{with } M_n = \text{diag}(e^{\pi i/k} \mathbf{1}_{n/2}, e^{-\pi i/k} \mathbf{1}_{n/2}) \quad (3.10)$$

namely  $(\gamma_{\Theta,7})_{ab} = \delta_{b,a+1} M_n$ . The orientifold action is given by

$$\gamma_{\Omega R,7} = \text{diag}(A_n, \dots, A_n) \quad (3.11)$$

with

$$A_n = \begin{pmatrix} 0 & i\mathbf{1}_{n/2} \\ i\mathbf{1}_{n/2} & 0 \end{pmatrix} \quad (3.12)$$

or

$$A_n = \begin{pmatrix} 0 & \mathbf{1}_{n/2} \\ -\mathbf{1}_{n/2} & 0 \end{pmatrix} \quad (3.13)$$

corresponding to the  $O8^+$  or  $O8^-$  plane on the T-dual side.

Let us discuss the spectrum after the orbifold projection, but before the orientifold projection. The results are shown in the first half of table 1. Recall that we start with a  $\mathbb{Z}_k$  action and have to distinguish the case of even and odd  $k$ . For odd  $k$  we have  $k$  sets of  $n$  branes, which we denote as  $D7_a$ -branes. For even  $k = 2P$  we have two  $\mathbb{Z}_k$ -unrelated families of  $P$  sets.

The matter content consists of an 8D piece and some matter localized at the 6D intersection. For the purposes of discussion, let us momentarily pretend that the D7 branes are somehow ‘compactified’ and phrase the spectrum in terms of  $D = 6$   $\mathcal{N} = 1$  SUSY. Namely we discuss the structure of the zero modes of the 8d fields in the bulk of the D7 branes. In the  $7_a 7_a$  sectors, we start with a gauge group  $U(n)^k$  and adjoint superpartners. For odd  $k$ , the  $\mathbb{Z}_k$  simply maps one set of branes to the next, and so reduces the group to just one  $U(n)$  and the matter to just one adjoint

hypermultiplet. For even  $k = 2P$ , the  $\mathbb{Z}_k$  projection on the original  $U(n)^P \times U(n)^P$  vector plus adjoint hypermultiplets can be regarded as acting in two steps. First, the  $\mathbb{Z}_P$  projection reduces to  $U(n) \times U(n)$ . Next, the remaining  $\mathbb{Z}_2$  maps each stack to itself, and projects the vector multiplets to  $[U(n/2) \times U(n/2)]^2$ , and the adjoint hypers to hypers in two copies of the  $(n/2, n/2; 1, 1) + (1, 1; n/2, n/2)$ . These spectra are easily obtained using the projection by the matrices (3.5), (3.10) on the original  $7_a 7_a$  spectrum, namely 6d  $\mathcal{N} = 2$  vector multiplets of  $U(n)^k$ .

Let us turn to the  $7_a 7_b$  sectors, for  $a \neq b$ . From each such sector we obtain one half-hypermultiplet (the other half comes from the  $7_b 7_a$  sector, which we count as a different one for the moment) in the bifundamental of  $U(n)_a \times U(n)_b$ . For odd  $k$  we get  $k(k-1)/2$  hypermultiplets in such representations, which are projected by  $\mathbb{Z}_k$  to  $(k-1)/2$  hypermultiplets in the adjoint of the surviving  $U(n)$ . For even  $k$ , open strings within each  $\mathbb{Z}_k$  invariant set give  $P(P-1)/2$  hypers in bifundamental representations. The  $\mathbb{Z}_P$  projection would leave  $(P-1)/2$  full hypers in the adjoint of each  $U(n)$ , which are projected down to  $(P-1)$  full hypers in the  $(n/2, n/2)$  of each  $U(n/2) \times U(n/2)$  by the additional  $\mathbb{Z}_2$  projection. Open strings stretched between the two  $\mathbb{Z}_k$  invariant sets give  $P^2$  bifundamental hypers, which are projected down to  $P$  hypers in the bifundamental of  $U(n)^2$  by the  $\mathbb{Z}_P$  projection. The additional  $\mathbb{Z}_2$  projection leaves  $P$  hypers in the  $(n/2, 1; n/2, 1) + (1, n/2; 1, n/2)$  of  $U(n/2)^2 \times U(n/2)^2$ .

Let us now consider introducing the orientifold projection, associated for example to an  $O8^-$  plane in the type I' T-dual. The result is shown in the second half of table 1. Let us again first look at the  $7_a 7_a$  sector. For odd  $k$  the orientifold projects the single  $U(n)$  down to  $SO(n)$ , and the matter to a hypermultiplet in the adjoint. For even  $k$ , within each  $\mathbb{Z}_k$  invariant set the orientifold projection relates the two  $U(n/2)$  factors. For each we obtain one  $U(n/2)$  gauge group, and two hypers in two-index antisymmetric representation.

In the  $7_a 7_b$  sector for  $a \neq b$ , imposing the orientifold projections for odd  $k$  projects the  $(k-1)/2$  adjoint hypermultiplets of  $U(n)$  to adjoints of  $SO(n)$ . For even  $k = 2P$ , orientifolding of open strings within each  $\mathbb{Z}_k$  invariant set leads to  $(P-1)$  full hypers in the two-index antisymmetric representation of  $U(n/2)$ . The projection on the spectrum of open strings stretched between different invariant sets yields  $P$  hypermultiplets in the bifundamental of  $U(n/2)^2$ .

For a single brane the interpretation of the scalar moduli in these multiplets is as follows: The scalars in the D7 brane bulk correspond to the motion of the D7 brane away from the fixed points. Due to the orbifold symmetry all the mirror images have to move as well, so that afterwards the branes form a regular  $k$ -gon, as displayed for  $k = 3$  in figure 3 and for  $k = 5$  in figure 4. In this configuration every brane still intersects every other brane. At each intersection there lives one of the hypermultiplets. For instance, the case  $k = 5$  in figure 4 contains two kinds of intersections, associated to two hypermultiplets in the  $7_a 7_b$  sectors. Turn-

6d (1,0) multiplet		Vector	$7_a 7_a$ hyper	$7_a 7_b$ hyper
Orbifold	$k$ odd	$U(n)$	Adj.	$\frac{k-1}{2}$ Adj.
	$k$ even	$U(n/2)^2$ $\times U(n/2)^2$	$2(\square, \square; 1, 1)$ $+ 2(1, 1; \square, \square)$	$(P-1) [(\square, \square; 1, 1) + (1, 1; \square, \square)]$ $P [(\square, 1; \square, 1) + (1, \square; 1, \square)]$
Orientifold	$k$ odd	$SO(n)$	$\square$	$\frac{k-1}{2} \square$
	$k$ even	$U(n/2)^2$	$2 \left( \begin{smallmatrix} \square \\ \square \end{smallmatrix}; 1 \right) + 2 \left( 1; \begin{smallmatrix} \square \\ \square \end{smallmatrix} \right)$	$(P-1) \left[ \left( \begin{smallmatrix} \square \\ \square \end{smallmatrix}; 1 \right) + \left( 1; \begin{smallmatrix} \square \\ \square \end{smallmatrix} \right) \right]$ $P (\square; \square)$

**Table 1:** Spectrum on D7-branes at angles in orbifold and orientifold singularities.

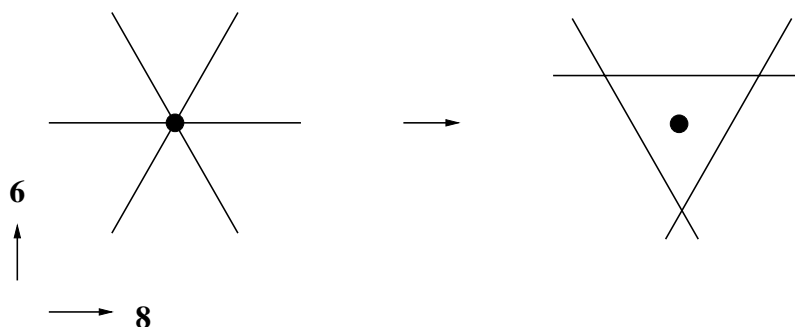

**Figure 3:** The 8d modulus for  $k = 3$ .

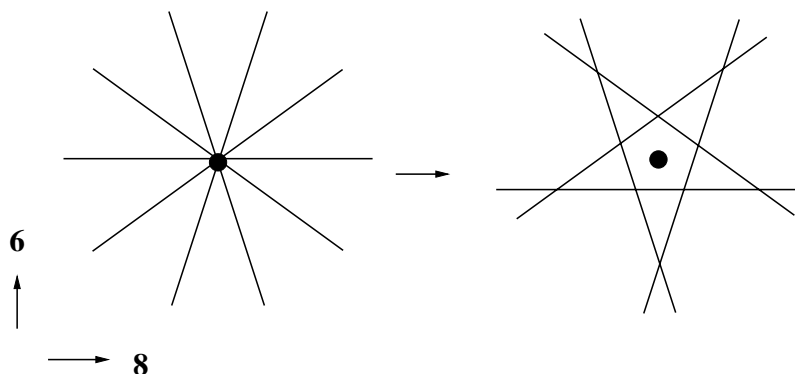

**Figure 4:** The 8d modulus for  $k = 5$ . The two kinds of intersections lead to two hypermultiplets.

ing on the vevs for such hypermultiplets corresponds to deforming the intersecting 7-brane configuration into a smooth curve, as in [10]. All intersections that are mapped into each other under the orbifold symmetry of course have to be turned on simultaneously, giving a nice geometric interpretation of the above counting of multiplets.

Let us conclude by mentioning that the six-dimensional chiral fermions localized at the intersections lead to an anomaly, which is nevertheless canceled by an anomaly inflow mechanism from the bulk of the D7 branes [26, 27, 28]

### 3.3 Closed string — open string duality

As already noted in early references [29, 30, 11, 12], an important restriction on open string configurations is the requirement that open and closed strings couple in a consistent fashion. By this we mean that the annulus, Möbius strip and Klein bottle amplitudes, computed in the open channel as 1-loop, should admit a consistent description in the closed channel as tree-level propagation between boundary and/or crosscap states.

This requirement has been studied in setups with branes at angles in [18], where strong consistency conditions were derived. The case addressed in [18] was on compact orbifold models and the above requirements imposed non-trivial restrictions on the choice of compactification lattices and orientifold actions on them. Our case is non-compact, and there is no such freedom as choosing a compactification lattice, hence one might worry about consistency of the models. In this section we show that the resulting models satisfy the requirements of open-closed duality.

Let us briefly go through the general procedure for the cylinder amplitude, which is enough to illustrate the point. We also restrict to odd  $k$  for simplicity. The cylinder amplitude in the open string channel is obtained by tracing over the open string spectrum and performing the orbifold and GSO projections. The result in our present context, for open strings stretching between the  $a^{th}$  and  $(a + r)^{th}$  stack of D7-branes, is easily obtained following the indications in [18]

$$\mathcal{A}_r = c(1 - 1) \int_0^\infty \frac{dt n^2}{t^4} \frac{1}{2} \frac{\vartheta \begin{bmatrix} 0 \\ 1/2 \end{bmatrix}^2 \vartheta \begin{bmatrix} r/k \\ 1/2 \end{bmatrix} \vartheta \begin{bmatrix} -r/k \\ 1/2 \end{bmatrix}}{\eta^6 \vartheta \begin{bmatrix} -1/2 + r/k \\ 1/2 \end{bmatrix} \vartheta \begin{bmatrix} 1/2 - r/k \\ 1/2 \end{bmatrix}}, \quad (3.14)$$

where the theta and eta functions have argument  $q = e^{-2\pi t}$ . The constant  $c$  encodes numerical factors irrelevant to our analysis. Also, for  $r = 0$  one should include momentum states, and some theta functions actually become eta functions, but we ignore this point to avoid cluttering.

In [18] the above amplitude was multiplied by a numerical factor corresponding to the intersection number of the D7 brane stacks. These factors played a crucial role in satisfying open-closed duality. Here we show that, even though our models do not contain such factors (there is only one intersection), a consistent amplitude is obtained in the tree channel.

Going to the tree channel by a modular transformation,  $t = 1/2l$ , the resulting amplitude is

$$\tilde{\mathcal{A}}_r = c(1 - 1) \int_0^\infty dl n^2 \frac{\tilde{\vartheta} \begin{bmatrix} 1/2 \\ 0 \end{bmatrix}^2 \tilde{\vartheta} \begin{bmatrix} 1/2 \\ r/k \end{bmatrix} \tilde{\vartheta} \begin{bmatrix} 1/2 \\ -r/k \end{bmatrix}}{\tilde{\eta}^6 \tilde{\vartheta} \begin{bmatrix} 1/2 \\ -1/2 + r/k \end{bmatrix} \tilde{\vartheta} \begin{bmatrix} 1/2 \\ 1/2 - r/k \end{bmatrix}}, \quad (3.15)$$

where the modular functions  $\tilde{\vartheta}$  and  $\tilde{\eta}$  are the usual  $\vartheta$  and  $\eta$  but with argument  $\tilde{q} = e^{-4\pi l}$ . This should admit the interpretation of tree-level closed string exchange between D7 brane boundary states, schematically,

$$\tilde{\mathcal{A}}_r \sim \langle D7_a | q^{L_0} \bar{q}^{\bar{L}_0} | D7_{a+r} \rangle. \tag{3.16}$$

Clearly, the result is independent of  $a$  since only the relative angle between D7 branes is relevant. Since the rotated state  $|D7_{a+r}\rangle$  is simply obtained by applying  $\Theta^r$  to  $|D7_a\rangle$ , we may write

$$\tilde{\mathcal{A}}_r \sim \langle D7 | q^{L_0} \bar{q}^{\bar{L}_0} \Theta^r | D7 \rangle. \tag{3.17}$$

with bra and ket representing states of parallel D7 branes. The amplitude (3.15) is easily seen to have the right structure: the numerator (resp. denominator) represents summing over the fermionic (resp. bosonic) oscillator states excited by the D7 brane boundary state, with the shifted lower characteristics in the theta functions corresponding to  $\Theta^r$  insertions. However, there is an important numerical factor that should also match. This factor appears because the theta functions of (3.15) have upper characteristic  $1/2$ , and have a product expansion

$$\tilde{\vartheta} \left[ \begin{matrix} 1/2 \\ 1/2 + \phi \end{matrix} \right] = 2 \sin(\pi\phi) \left[ \eta(\tau) \tilde{q}^{\frac{1}{12}} \prod_{n=1}^{\infty} (1 + \tilde{q}^n e^{2\pi i\phi})(1 + \tilde{q}^n e^{-2\pi i\phi}) \right]. \tag{3.18}$$

For theta functions in the numerator the factor  $2 \sin(\pi\phi)$  is expected, since it is associated to the trace of  $\Theta^r$  over fermion zero modes. For theta functions in the denominator such a factor does not arise in the trace over bosonic oscillators, and hence our tree-level result obtained from the loop channel by duality appears with an additional factor of  $1/(4 \sin^2 \pi r/k)$ . As mentioned above, in [18] the original loop amplitude had an additional multiplicity from multiple intersections, which (along with some numerical factors from the structure of the lattice) canceled the problematic factor, leading to correct tree channel amplitudes.

Our models are nevertheless consistent, because there is indeed an explanation for this factor in the tree amplitude. It arises from tracing over the momentum states excited by the D7 brane boundary state. Their contribution can be evaluated in analogy with a similar trace computed in [15, section 4.3]. Exchange in the tree channel involves momentum states, which form a continuum in the non-compact limit. In [15] the trace of  $\Theta^r$  over a continuum of momentum states in the four non-compact dimensions of  $\mathbb{C}^2/\mathbb{Z}_k$  yielded  $1/(4 \sin^2(\pi r/k))^2$ . In our case, momentum states excited by the D7 brane boundary state correspond to only two directions, hence give only ‘half’ of the contribution,  $1/(4 \sin^2(\pi r/k))$ , explaining that the factor implicit in (3.15) is actually correct.

More specifically, the trace of  $\Theta^r$  over a continuum of momentum modes is, in position space

$$\int dx_6 dx_8 \langle x_6, x_8 | \Theta^r | x_6 x_8 \rangle, \tag{3.19}$$

which, defining  $z_1 = x_6 + ix_7$ ,  $z_2 = x_8 + ix_9$ , is equal to

$$\begin{aligned}
 & \int d^2 z_1 d^2 z_2 \delta(x_7) \delta(x_9) \langle z_1, z_2 | e^{2\pi ir/k} z_1, e^{-2\pi ir/k} z_2 \rangle = \\
 & = \int d^2 z_1 d^2 z_2 \delta(x_7) \delta(x_9) \delta^{(2)}((1 - e^{2\pi ir/k}) z_1) \delta^{(2)}((1 - e^{-2\pi ir/k}) z_2) \\
 & = 1/(4 \sin^2(\pi r/k)). \tag{3.20}
 \end{aligned}$$

It is interesting to compare our result with the large volume limit of a compact example, of the type studied in [18]. In the compact case, there are precisely  $4 \sin^2(\pi r/k) \Theta^r$ -fixed points per complex plane, which is integer for crystallographic  $\mathbb{Z}_k$  ( $k = 2, 3, 4, 6$ ). Hence there is a cancellation of contributions in the integral from each fixed point with their total number, whereby giving no net multiplicity. In our non-compact case of  $\mathbb{C}^2/\mathbb{Z}_k$ , the unique fixed points gives the factor  $1/(4 \sin^2(\pi r/k))$  in the tree channel amplitude, consistently with the open string loop result.

### 3.4 Tadpoles

Consistency of the configuration would require cancellation of RR tadpoles which are not volume suppressed, i.e. RR charges whose flux cannot escape to infinity. As usual, untwisted tadpoles are not required to cancel, since they are volume suppressed and we work on non-compact setups. On the other hand, twisted RR tadpoles arising from disks associated to D7-branes, or from crosscaps associated to the orientifold projection would, if non-zero, lead to an inconsistency, since the sources for the corresponding charge fill all non-twisted non-compact directions, leading to no volume suppression.

Fortunately there are no such twisted tadpoles. Following [18] one can see that in either the Klein bottle, Moebius strip, or cylinder, only untwisted modes propagate in the tree channel amplitude (as can be seen in (3.15) for the cylinder). By factorization, this means that the branes and the orientifold planes do not carry charges under twisted modes. Hence the models are consistent without any constraint on the brane content of the theory.

For future application, it is however interesting to study configurations where untwisted tadpoles associated to D7 branes do cancel. We emphasize again that this is not required for consistency. However, it leads to the interesting property that the closed string fields have flat profiles in the resulting configuration. When some D brane probe is introduced in the theory, like D3 branes in Section 4, varying profiles correspond to running coupling constants (see e.g. [5, 31]), and flat profiles correspond to theories with no running, namely finite theories.

The value of the untwisted tadpoles associated to the D7 branes can be extracted from the analysis of [18], and gives the expected answer. For either odd or even  $k$ , each of the  $k$  O7 planes has charge  $-8$  (counted in D7 brane charge units, in the

covering space), as usual. Hence cancellation of untwisted tadpoles is achieved for  $n = 8$ , namely eight D7 branes on top of the each O7 plane.

Note that our construction seemingly leads to a puzzle. In the original HW type I' picture we have one O8 plane along 012345789 and several NS branes along 012345, with 7 a compact coordinate. T-dualizing along 7 we obtain a Taub-NUT space, with  $k$  coincident centers, so that locally we have  $\mathbb{C}^2/\mathbb{Z}_k$ . One would expect that after T duality, the O8 plane would map into two O7 planes sitting at opposite sides of the  $\mathbf{S}^1$  fiber in the TN space. Our proposed T-dual is however (centering on odd  $k$  for simplicity) just one O7 plane along  $z_1 = \bar{z}_1, z_2 = \bar{z}_2$ , and its orbifold images. Another related puzzle is that in the original type I' local charge cancellation is achieved for 16 D8 branes overlapping with the O8 plane, whereas in our type IIB picture it is achieved by 8 D7 branes overlapping the O7 planes.

These puzzles are solved because the T-dual description we are using is valid only in the near center region of Taub-NUT space, whereas the intuition about what the T-dual should be is good far from it, where the geometry splits as a (twisted) product of  $\mathbb{R}^3$  and  $\mathbf{S}^1$ . In order to extrapolate our description of the T-dual orientifold planes to the region far from the TN core, and compare with the intuitive expectations, the simplest way is to identify the  $\mathbf{S}^1$  orbit in  $\mathbb{C}^2/\mathbb{Z}_k$  and count the number of intersections with the O7 plane. The  $\mathbf{S}^1$  is the U(1) orbit  $(e^{i\lambda}U, e^{-i\lambda}V)$ , for  $\lambda$  from 0 to  $2\pi$ , in  $UV = Z^k$ . The O7 plane wraps the curve  $U = \bar{U}, V = \bar{V}$ , which can be parametrized by taking real  $U, V$ . This 2-cycle intersects the U(1) orbit at two opposite points. Hence by continuously deforming the  $\mathbf{S}^1$  fiber to the region far from the TN core, we learn that our single O7 plane looks like two O7 planes sitting at opposite points in  $\mathbf{S}^1$  in the asymptotic geometry. Similarly, the single set of 8 D7 brane in the near center region looks in the asymptotic region like 16 D7 branes, in two sets at opposite sides of  $\mathbf{S}^1$ . Hence our construction works just as required to reproduce the intuitive T-dual picture.

## 4. New brane constructions of 4d $\mathcal{N} = 1$ theories

As a first application of our type IIB orientifold construction, let us study a D3 brane probe on the orientifold geometry. In type I' this is a D4 brane along 01237, embedded in the O8 plane and stretched in between the stuck NS5 branes.

### 4.1 The brane and field theory calculations

As pointed out in [32], in addition to the standard branes for realizing  $\mathcal{N} = 1$  theories in 4 dimensions (see [33]), one may introduce one more component, a D8 brane in which the D4 brane is embedded. In our type I' picture this is realized when we introduce a D4 brane probe oriented along 01237. In the T-dual picture this corresponds to introducing a D3 brane probe along 0123. We will analyze the

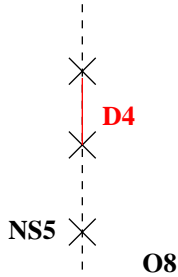

**Figure 5:** The D4 brane probe in type I'.

matter content expected from field theory and HW construction considerations, and then compare this with the actual calculation on the IIB side.

Let us analyze first the gauge theory on a D4 embedded in a D8 brane. As a second step we will introduce the O8 plane. Both are well known SUSY gauge theories with 8 supercharges. The final step is to study the gauge theories of D4 branes ending on NS5 branes, with the whole setup embedded inside the D8/O8 system.

A stack of  $N$  D4 branes inside  $n$  D8 branes on the compact 7 circle has an  $\mathcal{N} = 2$  SUSY  $SU(N)$  gauge theory on the 4d non-compact piece of their worldvolume. The matter content is that of the  $\mathcal{N} = 4$  SUSY theory on the D4 brane (a  $\mathcal{N} = 2$  vector and adjoint hypermultiplet) plus  $n$  additional hypermultiplets in the fundamental representation. The two adjoint scalars in the vector multiplet parameterize motion away from the D8 branes, and the four adjoint scalars in the hypermultiplet correspond to motion within the D8 brane. Turning on vevs for the  $n$  extra hypers resolves the D4 branes into instantons in the D8 brane gauge group. Adding an  $O8^-$  plane, one obtains an  $\mathcal{N} = 2$  SUSY  $USp(N)$  gauge theory with a hypermultiplet in the antisymmetric tensor representation and  $n/2$  additional fundamental hypermultiplets, with  $SO(n)$  global symmetry. Again the two scalars in the adjoint in the vector multiplet parameterize motion away from the O8 plane, while the four scalars in the antisymmetric tensor hypermultiplet parameterize motions within the O8 plane, and the fundamentals resolve the D4 branes into instantons. Similarly, introducing instead an  $O8^+$  plane, we can achieve an  $SO(N)$  gauge theory with a symmetric tensor hypermultiplet and  $n/2$  fundamentals, with  $USp(n)$  global symmetry.

Now consider  $N$  D4 branes with  $k$  NS5 branes embedded in  $n$  D8 branes, first in the absence of orientifold projection. The resulting theory has  $\mathcal{N} = 1$  SUSY in 4d. The gauge group is  $SU(N)^k$ . Each gauge factor has  $n$  fundamental and  $n$  antifundamental chiral multiplets  $Q_i, \tilde{Q}_i$  ( $i = 1, \dots, k$ ) from 4-8 strings. In addition we have the standard bifundamental chiral multiplets  $F_{i,i+1}, \tilde{F}_{i,i+1}$  from strings stretching across the NS5 branes. The adjoint hypermultiplet which corresponded to motions in 789 and to the Wilson line along 6 is eliminated by the NS brane boundary condition. However, there remains the adjoint chiral multiplet  $X_i$  from the  $\mathcal{N} = 2$  vector



multiplet, parameterizing the 45 motion. The 1-loop beta function of a given factor is proportional to

$$3\mu_{\text{adj}} - \mu_{\text{matter}} = 3(2N) - 2N - 2 \cdot N \cdot (1 + 1) - n \cdot (1 + 1) = -2n, \quad (4.1)$$

leading to an asymptotically non-free theory due to the extra D8 brane matter. The superpotential is

$$W = \sum_i \left[ F_{i,i+1} X_i \tilde{F}_{i,i+1} + \tilde{F}_{i-1,i} X_i F_{i-1,i} + Q_i \tilde{F}_{i,i+1} \tilde{Q}_{i+1} + \tilde{Q}_i F_{i,i+1} Q_{i+1} \right]. \quad (4.2)$$

The first two terms are the relics of the  $\mathcal{N} = 2$  system formed by the NS and D4 branes. The last two terms are allowed by gauge invariance, and should be included in order to break the global symmetry from the D8 branes from  $SU(n)^k$  down to  $SU(n)$ .

Including the  $O8^-$  plane, we obtain a  $USp(N)^k$  gauge group with an antisymmetric chiral multiplet  $A_i$ , one set of bifundamentals  $F_{i,i+1}$ , and  $n$  extra fundamentals  $Q_i$  in each group factor. The global symmetry is  $SO(n)$ , and the superpotential reads as above:

$$W = \sum_i [F_{i,i+1} A_i F_{i,i+1} + F_{i-1,i} A_i F_{i-1,i} + Q_i F_{i,i+1} Q_{i+1}]. \quad (4.3)$$

For  $n = 8$  we should obtain a finite theory. Indeed the 1-loop beta function is

$$3\mu_{\text{adj}} - \mu_{\text{matter}} = 3(N + 2) - (N - 2) - 2N - n = 8 - n, \quad (4.4)$$

which vanishes for  $n = 8$ . In order to check whether the theory is actually finite to all orders we perform an analysis following Leigh and Strassler [34]. Namely we show that the requirement that all (exact) beta functions vanish actually leads to linearly dependent equations, generically leading to lines of solutions instead of isolated solutions in coupling space. Since in our scenario all superpotential terms are cubic and the 1-loop beta vanishes, this line will pass through the origin of coupling space, i.e. weak coupling. Hence, along the line not only beta functions, but also the anomalous dimensions, will vanish and the theory is indeed finite.

The beta functions for the gauge coupling and the three terms in the superpotential are proportional to

$$\begin{aligned} \beta_{g_i} &\sim N\gamma_{F_{i,i+1}} + N\gamma_{F_{i-1,i}} + (N - 2)\gamma_{A_i} + 8\gamma_{Q_i} \\ \beta_{W_i^1} &\sim 2\gamma_{F_{i,i+1}} + \gamma_{A_i} \\ \beta_{W_i^2} &\sim 2\gamma_{F_{i,i-1}} + \gamma_{A_i} \\ \beta_{W_i^3} &\sim \gamma_{F_{i,i+1}} + \gamma_{Q_i} + \gamma_{Q_{i+1}}. \end{aligned}$$

Defining  $\gamma_F = \sum_i \gamma_{F_{i,i+1}}$ ,  $\gamma_A = \sum_i \gamma_{A_i}$ ,  $\beta_g = \sum_i \beta_{g_i}$  we see that these equations can be summed to obtain

$$\beta_g \sim 2N\gamma_F + (N - 2)\gamma_A + 8\gamma_Q$$

$$\begin{aligned}\beta_{W^1} &= \beta_{W^2} \sim 2\gamma_F + \gamma_A \\ \beta_{W^3} &\sim \gamma_F + 2\gamma_Q.\end{aligned}$$

Since  $W^1$  and  $W^2$  are derived from the same  $\mathcal{N} = 2$  relic we should put the corresponding couplings equal, as reflected in above. The equations above easily lead to the linear relation

$$\beta_g = 4\beta_{W^3} + (N - 2)\beta_{W^1},$$

which shows the existence of the desired line of RG fixed points.

## 4.2 The spectrum from the orientifold calculation

Let us reproduce the above results by performing the calculation in the T-dual type IIB orientifold construction. Locating  $Nk$  D3 branes at the origin in  $\mathbb{C}^2$ , strings stretching among D3 branes lead to an  $\mathcal{N} = 1$  vector multiplet  $V$  with group  $U(Nk)$ , and three adjoint chiral multiplets  $X^1, X^2, X^3$ , associated e.g. to the positions in  $z'_1 = z_1 + i\bar{z}_2$ ,  $z'_2 = \bar{z}_1 + iz_2$  and  $z_3 = x^4 + ix^5$ , respectively. Strings stretched between D3 branes and each  $D7_a$  brane stack lead to chiral multiplets  $H^{1,2}$  in the corresponding bifundamental representations.

In order to reproduce a finite theory, there should not exist D3 brane twisted tadpoles. This requires the action of  $\mathbb{Z}_k$  on D3 branes to be represented by a matrix

$$\gamma_{\Theta,3} = \text{diag}(\mathbf{1}_N, \omega\mathbf{1}_N, \dots, \omega^{k-1}\mathbf{1}_N), \quad (4.5)$$

with  $\omega = e^{2\pi i/k}$ . Representations other than the regular are consistent, but lead to non-finite theories.

The orientifold action maps each eigenspace of  $\gamma_{\Theta,3}$  to itself. It is possible to show, following an analysis similar to [25, section 2.2], that the symmetry of  $\gamma_{\Omega R,3}$  is equal in all subspaces. Hence, the projection corresponding to, for example an  $O8^-$  plane in the T-dual is

$$\gamma_{\Omega R,3} = \text{diag}(M_N, M_N, \dots, M_N), \quad \text{with } M = \begin{pmatrix} 0 & \mathbf{1}_{\frac{N}{2}} \\ -\mathbf{1}_{\frac{N}{2}} & 0 \end{pmatrix} = -M^{-1}. \quad (4.6)$$

The orbifold projection reads

$$\begin{aligned}V &= \gamma_{\Theta,3} V \gamma_{\Theta,3}^{-1} \\ X^1 &= \omega \gamma_{\Theta,3} X^1 \gamma_{\Theta,3}^{-1} \quad ; \quad H^1 = \gamma_{\Theta,3} H^1 \gamma_{\Theta,7}^{-1} \\ X^2 &= \omega^{-1} \gamma_{\Theta,3} X^2 \gamma_{\Theta,3}^{-1} \quad ; \quad H^2 = \gamma_{\Theta,7} H^2 \gamma_{\Theta,3}^{-1} \\ X^3 &= \gamma_{\Theta,3} X^3 \gamma_{\Theta,3}^{-1}.\end{aligned} \quad (4.7)$$

The 3-3 spectrum after the orbifold projection contains  $\mathcal{N} = 1$  vector multiplets of  $U(N)^k$  (as usual, the  $U(1)$  factors are expected to disappear by the T-dual of the bending mechanism in [35]), chiral multiplets  $F_{i,i+1}, \tilde{F}_{i,i+1}$  in bifundamental representations, and  $X_i$  in the adjoint.

In the  $37 + 73$  sector, for odd  $k$ , the orbifold projection simply identifies the sets of  $D7_a$  branes and splits the D3 brane group. So after the orbifold projection we get chiral multiplets  $Q_i, \tilde{Q}_i$  in representations  $(N_i, n)$ . For even  $k = 2P$ , the  $\mathbb{Z}_P$  projection leads to a D3 brane group  $U(2N)^P$ , and leads to two sets of chiral multiplets in the  $(2N_i; n, 1) + (2N_i; 1, n)$ . The additional  $\mathbb{Z}_2$  projections breaks the D3 group down to  $U(N)^k$ , and the D7 group to  $U(n/2)^2 \times U(n/2)^2$ , and leads to two sets of chiral multiplets in the  $(N_{2i}; n/2, 1, 1, 1) + (N_{2i+1}; 1, n/2, 1, 1) + (N_{2i}; 1, 1, n/2, 1) + (N_{2i+1}; 1, 1, 1, n/2)$ .

The orientifold projection is

$$\begin{aligned}
 V &= -\gamma_{\Omega R,3} V^T \gamma_{\Omega R,3}^{-1} \\
 X^1 &= \gamma_{\Omega R,3} (X^2)^T \gamma_{\Omega R,3}^{-1} ; & H^1 &= \gamma_{\Omega R,3} (H^2)^T \gamma_{\Omega R,7}^{-1} \\
 X^2 &= \gamma_{\Omega R,3} (X^1)^T \gamma_{\Omega R,3}^{-1} ; & H^2 &= \gamma_{\Omega R,7} (H^1)^T \gamma_{\Omega R,3}^{-1} \\
 X^3 &= \gamma_{\Omega R,3} (X^3)^T \gamma_{\Omega R,3}^{-1} .
 \end{aligned}
 \tag{4.8}$$

The 3-3 spectrum is as follows: there are vector multiplets of  $USp(n)^k$ , chiral multiplets  $A_i$  in the antisymmetric representation, and one set of chiral multiplets  $F_{i,i+1}$  in bifundamentals.

In the mixed sector, the orientifold projection relates the 37 and 73 sectors. For odd  $k$  we obtain one set of chiral multiplets in representations  $(N_i, n)$  of the  $i^{th}$   $USp(N)$  factor in the D3 branes and the D7 brane  $SO(n)$  group. The case  $n = 8$  leads to 8 fundamental flavours for each symplectic factor, and corresponds to a finite theory, as anticipated from the untwisted tadpole computation in section 3.4. For even  $k$  we obtain chiral multiplets in the representations  $(N_i; n/2; 1) + (N_i; 1, n/2)$  of the  $i^{th}$   $USp(N)$  D3 brane factor, and the D7 brane  $U(n/2)^2$ . Again, for  $n = 8$  we obtain 8 chiral multiplets in the fundamental of  $USp(N_i)$ , as required for finiteness.

Hence the corresponding spectra agree with those obtained in the HW brane construction. Superpotential interactions are also easily seen to agree with (4.3). This provides a check and a nice application of our proposed T duality for stuck NS branes.

## 5. The heterotic string on an ADE singularity

### 5.1 The problem

In the linear sigma model (LSM) approach of [36], instead of directly writing down the conformally invariant non-linear sigma model describing the propagation of a string in a given background, one starts with a 2d gauge theory, which in the UV is just a free theory. Under the renormalization group flow the couplings evolve and settle to their conformal values. As shown in [36, 37], as long as we ensure the existence of an anomaly free R-symmetry, we can expect a non-trivial CFT in the IR. Otherwise the model will just flow to a massive and hence free theory.

D1 branes naturally provide us with 2d gauge theories. At strong coupling, that is in the deep IR, these D-brane gauge theories flow to the non-linear sigma model of the fundamental string in an S-dual background. In this way the IIB string can be constructed as the  $\mathcal{N} = (8, 8)$  SUSY theory of the D1 brane in IIB, the (0,8) theory of the D1 string in type I gives us the heterotic string [38] and the Coulomb branch of the D1 D5 system describes fundamental strings propagating in the torsional metric set up by NS5 branes [39].

In the same spirit we would like to study the LSM living on the worldvolume of a D1 brane in type I on an ALE space. In the T-dual type I' picture, the linear sigma model lives on a D2 brane along 016 stretched on the interval between two O8 planes. The linear sigma model on the D2 brane has (0,4) supersymmetry. In the phase with the NS5 branes out in the bulk the worldvolume theory is easily determined by using the T-duality along 6. The gauge group consists of a (4,4) supersymmetric sector, which is a quiver like theory with bifundamental matter and gauge group

$$SO(1) \times U(1) \times U(1) \times \cdots \times U(1) \times SO(1)$$

for a  $\mathbb{Z}_{2P}$  singularity and a vector bundle with vector structure, and

$$U(1) \times U(1) \times U(1) \times \cdots \times U(1) \times U(1)$$

with extra ‘symmetric tensors’, i.e. singlets, in the two factors at the end of the chain for a  $\mathbb{Z}_{2P}$  singularity and a vector bundle with vector structure, and

$$SO(1) \times U(1) \times U(1) \times \cdots \times U(1) \times U(1)$$

with an extra singlet in the last  $U(1)$  for  $\mathbb{Z}_{2P+1}$ . In addition we couple to the (0,8) matter sector from the D8 branes, breaking the SUSY down to (0,4). These matter fields encode the gauge bundle.

Heterotic string theory in this phase has marginal operators corresponding to blowing up  $P$  of the 2-spheres, to NS-NS fluxes through these spheres, and to turning on the vevs for  $P$  tensor multiplets ( $P - 2$  for the case with two stuck NS5 branes). In the linear sigma model these correspond to FI terms, theta angles and ratios of gauge couplings. While the former two are marginal couplings of the CFT we flow to in the IR, the role of the latter is not clear. In the analog (4,4) situation, type IIB D1 string probe on ALE spaces, the ratio of gauge couplings correspond to RR 2-form fluxes through the spheres of the ALE space. It can be shown [40] that the ratios are actually irrelevant on the Higgs branch theory which flows to the NLSM describing the IIB string on the ALE space, and that they are only marginal on the Coulomb branch. This is in agreement with the fact that CFT is mostly insensitive to RR potential backgrounds, which only modify the one-point function on the disk. It would be interesting to study if the situation changes in the (0,4) context.<sup>3</sup>

---

<sup>3</sup>We are indebted to Ofer Aharony and Mike Douglas for illuminating discussions on this point.

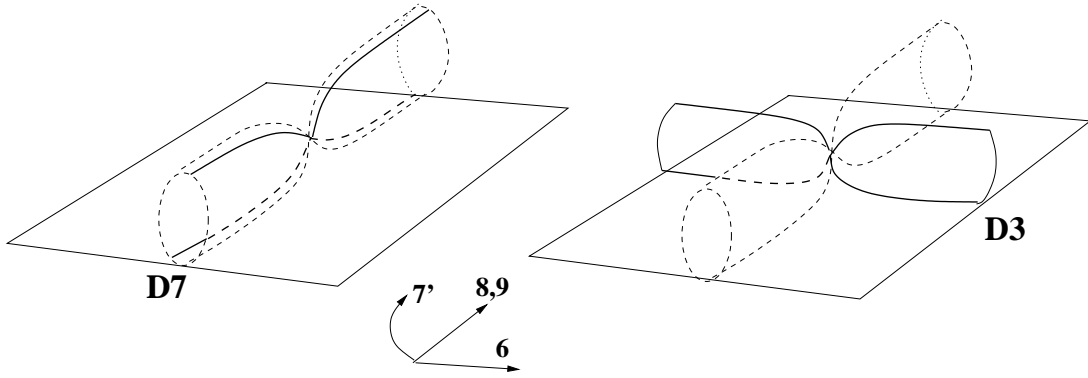

**Figure 6:** The 2-cycles in the Taub-NUT geometry, for D7/O7 and for D3 branes.

Instead, we would like to understand the LSM on the D2 brane in the other phase, that is with stuck NS branes leading to hypermultiplet moduli, and no tensor multiplets. This provides the LSM for heterotic string theory on the ALE space. Inclusion of D6 branes then yields a LSM model realizing an ADHM construction for SO instantons on the ALE space.

## 5.2 Using the new T-duality

As has been discussed above, one can obtain some information of the D1 brane probe in type I theory on an ALE space by considering a D2 brane probe (along 017) in the type I' model with NS branes stuck at one of the O8 planes. We consider the situation with the dimension 7 compactified on a circle, and study the system after T-dualizing along that direction. We also momentarily consider the dimension 6 to be non-compact. As shown in section 3, the set of NS branes transforms into a  $k$ -centered TN space (different from the original one in type I), and the O8 plane maps into O7 planes corresponding to orientifold actions of type (3.3).

The location of the TN centers in 89 correspond to the original 89 locations of the NS branes. We are interested in the case of coinciding centers, and the geometry near the TN core is that of  $\mathbb{C}^2/\mathbb{Z}_k$ . On the other hand, positions of NS branes in 7 correspond to NS-NS B fluxes on the collapsed two-cycles, hence the perturbative orbifold description, where all B-fields are equal, forces us to consider the NS branes equally distributed on the 7 circle. This implies that in the original type I theory we are studying the theory at  $B = 0$ , but with non-zero blow-ups in the direction 7. Hence, the information we can obtain from the T-dual picture actually is associated to the LSM for the case of blown-up ALE, as we will see in figure 6.

Let us discuss the T duality on a D2 brane ending on a NS brane. The type I' D2 brane is not wrapped on the 7 circle, hence we expect it to map to a D3 brane wrapped on a two-cycle in the TN geometry. The T-duality of this object is very similar to that of D6 branes ending on NS branes, analyzed in [41], except that we are using a different preferred complex structure. In our case, the corresponding

2-cycle is a special lagrangian cycle wrapped along the  $S^1$  fiber in TN. In fact, in the situation with the dimension 6 is non-compact, ‘half’ D2 branes ending on a NS brane, extending along either positive or negative values of  $x^6$ , map to different 2-cycles. Moreover, since the orientifold action flips the sign of  $x^6$ , it exchanges both kinds of half branes, hence in the T-dual picture  $\Omega R$  should exchange the two 2-cycles.

This determines that the two 2-cycles are described, in the covering space of the  $\mathbb{C}^2/\mathbb{Z}_k$  orbifold, as

$$z_1 = i\bar{z}_2, \quad \bar{z}_1 = -iz_2 \quad \text{and} \quad z_1 = -i\bar{z}_2, \quad \bar{z}_1 = iz_2. \quad (5.1)$$

Notice that they indeed are wrapped on the  $U(1)$  orbit of the background geometry. Also notice that they are related by an  $SU(2)$  rotation to the 2-cycle associated to D7/O7 (e.g.  $z_1 = \bar{z}_1, z_2 = \bar{z}_2$ ) hence they preserve the correct number of supersymmetries. Finally, since the above curves are invariant under the orbifold, we need not include  $\mathbb{Z}_k$  image D3 branes. The 2-cycles associated to the D7/O7 system, and to the D3 branes are depicted in figure 6.

When the direction 6 is considered compact, the T-dual geometry is an ‘ALG space’, with two asymptotically compact directions, which can be constructed as an infinite (periodic in 6) array of  $k$ -centered TN spaces. In this situations, the two above 2-cycles are in fact joined smoothly in the  $x^6$  region opposite the TN core. This is in analogy with the way the two half D2 branes are smoothly joined on the side of the 6 circle opposite to the location of the NS brane in the type I’ picture.

Let us compute the spectrum and low energy effective action on such D3 brane probe. It is useful to first consider the situation without orientifold projection, and also with non-compact 6. This exercise is analogous to that performed in [41] for sets of half D6-branes.

First, notice that D3 branes wrapped on the 2-cycles (5.1), subsequently denoted D3 and D3’ branes, are fixed by the orbifold action, hence we have the possibility of specifying a non-trivial action of the Chan-Paton indices. The general choice would be

$$\gamma_{\theta,3} = \text{diag}(\mathbf{1}_{n_0}, \dots, \omega^{k-1} \mathbf{1}_{n_{k-1}}) \quad (5.2)$$

and a similar expression for D3’ branes. Geometrically, these matrices specify flat connections on the D brane bundles on the asymptotic region of  $\mathbb{C}^2/\mathbb{Z}_k$ , or, in the context of TN (rather than ALE) geometry, asymptotic Wilson lines along the  $S^1$  fiber. They hence correspond to different positions in 7 in the type I’ picture. Different fractional D3, D3’ branes correspond to half D2 branes ending on the different NS branes, located at different 7 positions. Our probe is a particular case of one pair of fractional D3, D3’ branes, with equal eigenvalue, specifying on which NS brane the T dual half D2 brane is ending. Notice that the Wilson line degree of freedom is to be considered a dynamical modulus in the final field theory, and in that sense allows to continuously interpolate between different choices of fractional D3, D3’ branes.

Centering on this particular case of a single probe, we set without loss of generality  $n_0 = n'_0 = 1$ , and  $n_i = n'_i = 0$  for  $i \neq 0$ , and compute the spectrum. The 33 spectrum is obtained by the familiar projection, and leads to a U(1) gauge theory with 8 supersymmetries. Expressing it in the language of 2d (4,4) susy (namely working only with zero modes of the 4d fields), we get a (4,4) U(1) vector multiplet. Its four scalars parameterize the location of the D3 brane (or the T dual D2 brane) in 2345. The 3'3' spectrum leads to a similar spectrum. If 6 is non-compact, they are independent fields, but with compact 6 they correspond to the same degrees of freedom and we get only one copy of this spectrum. The 33' spectrum gives rise to one hypermultiplet in the bifundamental representation. Since the D3 and D3' branes have equal eigenvalue, it survives the orbifold projection. When the direction 6 is taken compact, the bifundamental collapses to an adjoint representation. The scalars in this field parameterize the recombination of the two intersecting slugs into a single smooth one, very much like in [10, 42]. Concretely, the deformed curve reads

$$(z_1 - i\bar{z}_2)(z_2 - i\bar{z}_1) = \epsilon \tag{5.3}$$

and splits into two intersecting 2-cycles for  $\epsilon = 0$ . Hence the full 2d spectrum on our probe is a (4,4) U(1) vector multiplet and one (4,4) adjoint, namely neutral, hypermultiplet. For  $N$  overlapping probes, the gauge symmetry is enhanced to U( $N$ ).

The orientifold projection is easily analyzed. It maps D3 to D3' branes and vice versa, reducing the spectrum (for compact 6) as follows. The (4,4) U( $N$ ) vector multiplet is projected down to a (0,4) SO( $N$ ) vector multiplet, and a (0,4) chiral multiplet (containing four real scalars and four MW right-handed fermions) in the symmetric. The (4,4) hypermultiplet is projected down to a (0,4) chiral multiplet in the two-index symmetric representation, and a (0,4) 'Fermi' multiplet (containing four MW left fermions) in the antisymmetric representation. For  $N = 1$  we just get two (0,4) chiral multiplets.

Notice that the SO( $N$ ) theory we have described would suffer from 2d gauge anomalies. However, one should recall that the full 2d theory also contains states from strings stretched between the D2 and the D8 branes in the type I' picture. They can be easily read out from this picture to correspond to 32 MW left fermions in the fundamental of SO( $N$ ), and cancel the 2d anomaly. Alternatively, one can do the equivalent computation in the type IIB orbifold picture, by introducing D7 branes at angles, like in section 3, and computing the spectrum of strings between the D3 and D7 branes. The cancellation of anomalies is a non-trivial check that our procedure or reading the piece of the spectrum associated to the intersection of D2, NS branes and O8 planes by using a T dual orbifold construction is indeed consistent.

It is time to ask for what physics the 2d LSM is describing. In particular if our computation has captured the LSM of the type I D1 brane in ALE space, the Higgs

moduli space of our theory should reproduce the background geometry felt by the type I D1 brane, a  $k$ -center Taub-Nut (or ALE) space (different from the one in the type IIB orientifold description). Unfortunately this seems not to be the case.

In fact, there are several hints suggesting that our 2d field theory does not really describe the propagation of a string in ALE space. In fact, since the D3 brane probe in the type IIB orientifold is fractional, it couples to at most one blow-up parameter, which can be shown to appear as a FI term in the field theory as usual. This suggests that the D-brane probe is sensitive to the geometry of just one TN center, not all  $k$  of them. Another piece of evidence comes from the actual 2d spectrum, which is exactly that of a D1 brane probe in flat space. This suggests that the moduli space of the theory is smooth, again suggesting the brane is sensitive to just one TN center. Finally, this can be blamed, using the T-dual type I' picture, to the fact that the D2 brane probe is sitting at a definite position in 7 and the NS branes are located at different positions in 7. Hence, the D2 brane can be made to coincide with at most one NS brane. States that would become massless when the D2 brane approaches other centers are generically massive. This fact is geometrically manifest in the type I' picture, but not in the type IIB orientifold setup, where it is however correctly recovered when one computes the spectrum on the probe.

This should be understood as follows. By construction, the D1 brane probe in type I must have full ALE geometry as its target space. Its worldvolume theory has to contain parameters corresponding to all the blow-up modes. However, since the D1 string maps into a single D2 brane in type I' and the single D2 maps only to a single fractional brane in our T-dual picture, our calculation produces a field theory that is only sensitive to a single blow-up. The issue is that in our calculation we have only evaluated the massless sector. In order to probe the presence of the other NS5 branes, we would have to include states whose mass is roughly “twice the distance” to the other branes. Our perturbative orientifold is only valid if the NS5 branes are equally spaced, so this distance is just  $R_7/k$ . While one can in principle calculate the massive spectrum in the orientifold as well, the problem is that the orientifold only captures the near-core region of the full T-dual Taub-Nut geometry, so we are neglecting states of mass  $R_7$  anyway (which would come from strings winding around the circle at infinity). The orientifold hence does not encode the right spectrum at the massive level. So in order to get the ADHM construction we were looking for, more refined tools to evaluate the spectrum are necessary. We however hope that the T-dual picture we have described is useful in further developments on this issue.

## Acknowledgments

We would like to thank Ofer Aharony, Gerardo Aldazabal, Ralph Blumenhagen, Mike Douglas, Sebastián Franco, Luis Ibáñez, Boris Körs, Raúl Rabadán for very useful discussions, and especially Mina Aganagic for many helpful questions and comments.



A. M. U. thanks M. González for kind encouragement and support. This work was partially supported by the U.S. Department of Energy under contract # DE-FC02-94ER40818. Y.H.H. is also supported in part by the Presidential Fellowship of MIT.

## References

- [1] A. Hanany and E. Witten, *Type IIB superstrings, BPS monopoles and three-dimensional gauge dynamics*, *Nucl. Phys.* **B 492** (1997) 152 [[hep-th/9611230](#)].
- [2] H. Ooguri and C. Vafa, *Two-dimensional black hole and singularities of CY manifolds*, *Nucl. Phys.* **B 463** (1996) 55 [[hep-th/9511164](#)].
- [3] I. Brunner and A. Karch, *Branes at orbifolds versus Hanany witten in six dimensions*, *J. High Energy Phys.* **03** (1998) 003 [[hep-th/9712143](#)].
- [4] A. Hanany and A. Zaffaroni, *Branes and six dimensional supersymmetric theories*, *Nucl. Phys.* **B 529** (1998) 180 [[hep-th/9712145](#)].
- [5] A. Karch, D. Lust and D. Smith, *Equivalence of geometric engineering and Hanany-Witten via fractional branes*, *Nucl. Phys.* **B 533** (1998) 348 [[hep-th/9803232](#)].
- [6] J. Park and A.M. Uranga, *A note on superconformal  $N = 2$  theories and orientifolds*, *Nucl. Phys.* **B 542** (1999) 139 [[hep-th/9808161](#)].
- [7] A.M. Uranga, *Brane configurations for branes at conifolds*, *J. High Energy Phys.* **01** (1999) 022 [[hep-th/9811004](#)].
- [8] K. Dasgupta and S. Mukhi, *Brane constructions, conifolds and M-theory*, *Nucl. Phys.* **B 551** (1999) 204 [[hep-th/9811139](#)].
- [9] A. Hanany and A.M. Uranga, *Brane boxes and branes on singularities*, *J. High Energy Phys.* **05** (1998) 013 [[hep-th/9805139](#)].
- [10] M. Aganagic, A. Karch, D. Lust and A. Miemiec, *Mirror symmetries for brane configurations and branes at singularities*, *Nucl. Phys.* **B 569** (2000) 277 [[hep-th/9903093](#)].
- [11] M. Bianchi and A. Sagnotti, *On the systematics of open string theories*, *Phys. Lett.* **B 247** (1990) 517.
- [12] M. Bianchi and A. Sagnotti, *Twist symmetry and open string Wilson lines*, *Nucl. Phys.* **B 361** (1991) 519.
- [13] E.G. Gimon and J. Polchinski, *Consistency conditions for orientifolds and D-manifolds*, *Phys. Rev.* **D 54** (1996) 1667 [[hep-th/9601038](#)].
- [14] A. Dabholkar and J. Park, *Strings on orientifolds*, *Nucl. Phys.* **B 477** (1996) 701 [[hep-th/9604178](#)].

- [15] E.G. Gimon and C.V. Johnson, *K3 orientifolds*, *Nucl. Phys.* **B 477** (1996) 715 [[hep-th/9604129](#)].
- [16] J.D. Blum and K. Intriligator, *New phases of string theory and 6D RG fixed points via branes at orbifold singularities*, *Nucl. Phys.* **B 506** (1997) 199 [[hep-th/9705044](#)].
- [17] A. Hanany and A. Zaffaroni, *Monopoles in string theory*, *J. High Energy Phys.* **12** (1999) 014 [[hep-th/9911113](#)].
- [18] R. Blumenhagen, L. Gorlich and B. Kors, *Supersymmetric orientifolds in 6D with D-branes at angles*, *Nucl. Phys.* **B 569** (2000) 209 [[hep-th/9908130](#)].
- [19] E. Witten, *Heterotic string conformal field theory and A-D-E singularities*, *J. High Energy Phys.* **02** (2000) 025 [[hep-th/9909229](#)].
- [20] J. Polchinski, *Tensors from K3 orientifolds*, *Phys. Rev.* **D 55** (1997) 6423 [[hep-th/9606165](#)].
- [21] M. Berkooz et al., *Anomalies, dualities and topology of  $D = 6$   $N = 1$  superstring vacua*, *Nucl. Phys.* **B 475** (1996) 115 [[hep-th/9605184](#)].
- [22] R. Blumenhagen, L. Gorlich and B. Kors, *Supersymmetric 4D orientifolds of type IIA with D6-branes at angles*, *J. High Energy Phys.* **01** (2000) 040 [[hep-th/9912204](#)].
- [23] S. Forste, G. Honecker and R. Schreyer, *Supersymmetric  $\mathbb{Z}_N \times \mathbb{Z}_m$  orientifolds in 4D with D-branes at angles*, *Nucl. Phys.* **B 593** (2001) 127 [[hep-th/0008250](#)].
- [24] B. Craps and M.R. Gaberdiel, *Discrete torsion orbifolds and D-branes. II*, *J. High Energy Phys.* **04** (2001) 013 [[hep-th/0101143](#)].
- [25] A.M. Uranga, *A new orientifold of  $\mathbb{C}^2/\mathbb{Z}_N$  and six-dimensional rg fixed points*, *Nucl. Phys.* **B 577** (2000) 73 [[hep-th/9910155](#)].
- [26] M.B. Green, J.A. Harvey and G. Moore, *I-brane inflow and anomalous couplings on D-branes*, *Class. and Quant. Grav.* **14** (1997) 47 [[hep-th/9605033](#)].
- [27] J. Bogdan Stefanski, *Gravitational couplings of D-branes and o-planes*, *Nucl. Phys.* **B 548** (1999) 275 [[hep-th/9812088](#)].
- [28] J.F. Morales, C.A. Scrucca and M. Serone, *Anomalous couplings for D-branes and O-planes*, *Nucl. Phys.* **B 552** (1999) 291 [[hep-th/9812071](#)].
- [29] A. Sagnotti, *Open strings and their symmetry groups*, talk presented at the Cargese Summer Institute on *Non-perturbative methods in field theory*, Cargese, France, Jul 16–30, 1987.
- [30] G. Pradisi and A. Sagnotti, *Open string orbifolds*, *Phys. Lett.* **B 216** (1989) 59.
- [31] R.G. Leigh and M. Rozali, *Brane boxes, anomalies, bending and tadpoles*, *Phys. Rev.* **D 59** (1999) 026004 [[hep-th/9807082](#)].

- [32] O. Aharony and A. Hanany, *Branes, superpotentials and superconformal fixed points*, *Nucl. Phys. B* **504** (1997) 239 [[hep-th/9704170](#)].
- [33] A. Giveon and D. Kutasov, *Brane dynamics and gauge theory*, *Rev. Mod. Phys.* **71** (1999) 983–1084 [[hep-th/9802067](#)].
- [34] R.G. Leigh and M.J. Strassler, *Exactly marginal operators and duality in four-dimensional  $N = 1$  supersymmetric gauge theory*, *Nucl. Phys. B* **447** (1995) 95 [[hep-th/9503121](#)].
- [35] E. Witten, *Solutions of four-dimensional field theories via M-theory*, *Nucl. Phys. B* **500** (1997) 3 [[hep-th/9703166](#)].
- [36] E. Witten, *Phases of  $N = 2$  theories in two dimensions*, *Nucl. Phys. B* **403** (1993) 159 [[hep-th/9301042](#)].
- [37] E. Silverstein and E. Witten, *Global  $U(1)$   $\mathbb{R}$ -symmetry and conformal invariance of  $(0, 2)$  models*, *Phys. Lett. B* **328** (1994) 307 [[hep-th/9403054](#)].
- [38] J. Polchinski and E. Witten, *Evidence for heterotic-type I string duality*, *Nucl. Phys. B* **460** (1996) 525 [[hep-th/9510169](#)].
- [39] E. Witten, *Some comments on string dynamics*, [hep-th/9507121](#).
- [40] O. Aharony and M. Berkooz, *IR dynamics of  $D = 2$ ,  $N = (4, 4)$  gauge theories and DLCQ of 'little string theories'*, *J. High Energy Phys.* **10** (1999) 030 [[hep-th/9909101](#)].
- [41] J. Park, R. Rabadan and A.M. Uranga,  *$N = 1$  type IIA brane configurations, chirality and T-duality*, *Nucl. Phys. B* **570** (2000) 3 [[hep-th/9907074](#)].
- [42] M. Aganagic and C. Vafa, *Mirror symmetry, D-branes and counting holomorphic discs*, [hep-th/0012041](#).