

Photodiode read-out of the ALICE Photon Spectrometer PbWO₄ crystals

V.I. Manko, M. Ippolitov, I. Sibiriak, M. Volkov

Russian Research Centre “Kurchatov Institute”, Kurchatov square 1, 123182 Moscow, Russia

A. Klovning, O. Maeland, O.H. Odland, R. Rongved

Department of Physics, University of Bergen, Allégt 55, 5007 Bergen, Norway

B. Skaali

Department of Physics, University of Oslo, POB 1048 Blindern, 0316 Oslo, Norway

Abstract: The PHOTon Spectrometer of the ALICE experiment is an electromagnetic calorimeter of high granularity consisting of four detector modules with a total of 17280 lead-tungstate (PbWO₄) crystals of dimensions 22x22x180 mm³, read out by large-area PIN-diodes with very low-noise preamplifiers. The crystals are operated at -25°C to increase the crystal light yield a factor of ~3 higher than at room temperature. A 16.1x17.1 mm² PIN photo-diode, optimized for the PbWO₄ emission spectrum at 400-500nm, has been developed. The charge sensitive preamplifier is built in discrete logic with two input JFETs for optimum matching with the high capacitance (~150pF) PIN-diode. The PIN-diode and preamplifier are integrated by mounting them to common ceramic frame. Coupled to a matching shaper circuitry, the ENC¹ measured at the operating temperature is less than 600 e⁻. Beam tests demonstrate that the required energy resolution of the PHOS is reached.

1. Introduction

The PHOS (PHOTon Spectrometer) of the ALICE experiment[1] is an electromagnetic calorimeter of high granularity optimized for measuring photons, π^0 's and η mesons in the momentum ranges ~0.5-10, ~1-10 and ~2-10 GeV/c, respectively. Furthermore, PHOS will also detect charged and neutral hadrons: pions, kaons, protons, neutrons and antineutrons. For additional rejection of charged hadrons a charged-particle veto detector is placed in front of the PHOS detector. The design and physics performance of PHOS calorimeter are described in [2].

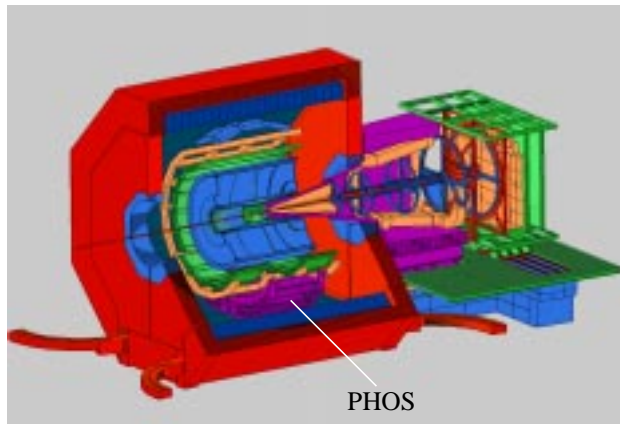

Figure 1. The ALICE detector with PHOS calorimeter.

2. Detection geometry for PHOS

The highest estimate for the number of charged particles produced in central Pb-Pb collisions at ALICE is ~8000 per unit of rapidity at mid-rapidity. This requires a small cross-section of the detection cell, and the use of a very dense medium with the smallest Molière radius, a high segmentation of the calorimeter, and the largest possible distance to the vertex. Therefore, lead tungstate (PbWO₄) crystals have been chosen as detection material.

The PHOS calorimeter consists of four identical detector modules of size ~1 x 2 m² facing the interaction point, see Figure 2. Each module contains 4320 PbWO₄ crystals of size 22x22x180 mm³, giving a total of 17280 crystals. The length of 180 mm is a compromise between the detector performance and production costs. For this length the degradation in energy resolution from the punch-through effect from charged particles traversing the PIN-diodes is small for the photon energy range ~0.5-10 GeV. The total crystal volume is ~1.5 m³ with a total weight of ~12.5 tons.

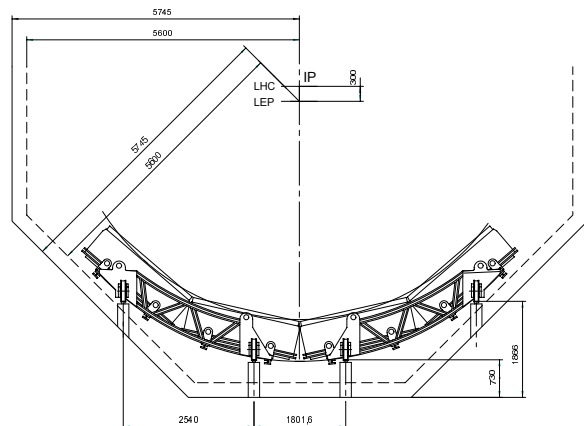
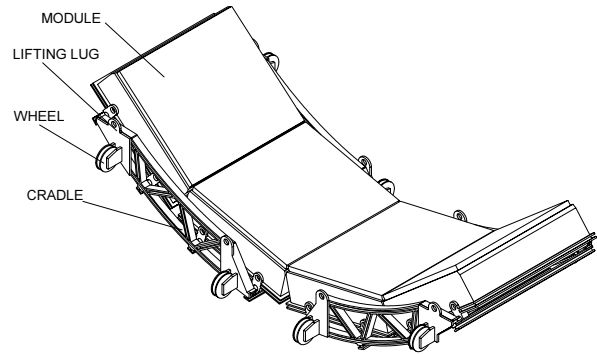

Figure 2. The geometry of the PHOS calorimeter.

¹ ENC = Equivalent Noise Charge

2.1 Properties of $PbWO_4$ crystals

Lead tungstate $PbWO_4$ (PWO) is a fast scintillating crystal with a rather complex emission spectrum with two main components: a blue component peaking at ~ 420 nm and a green component peaking at ~ 500 nm. The light yield of PWO at room temperature is low compared with other heavy scintillating crystals, for instance BGO. However, the yield depends strongly on the temperature with a coefficient of $\sim -2\%$ per $^\circ C$. At the selected operating temperature for PHOS at $-25^\circ C$ the light yield is about a factor of 3 higher than at room temperature.

Table 1: Properties of $PbWO_4$

Density	8.28 g/cm ³
Radiation length	0.89 cm
Interaction length	19.5 cm
Molière radius	2.0 cm
Melting point	1123 $^\circ C$
Hardness	4 Moh
Refractive index along ζ axis ($\lambda = 632$ nm)	2.16

The optical and mechanical properties of PWO crystals have been extensively studied as part of the PHOS R&D program, see [2]. An optimization of the crystal growth, annealing and machining technology has been carried out. In a light-yield measurement of more than 200 crystals, performed with a ^{22}Na radioactive source, the relative width of the light-yield distribution was $\sim 10\%$. In radiation damage studies no irreversible processes were observed during irradiation up to doses above 1000 Gy; the initial light transmission property of the samples was restored by heating to $200^\circ C$.

3. The PHOS photodetector

3.1 Energy and spatial resolution requirements

In order to reach the energy and spatial resolution requirements for the PHOS detector, the following conditions must be met:

- To achieve a sufficient high light yield the crystals will be operated at $-25^\circ C$ with a stability of $0.3^\circ C$.
- At this operating temperature the ENC noise in the PIN photo-diode unit must be less than $600e^-$. This is a very low value taking into account the high capacitance of 150-200 pF of the large PIN-diodes.
- The dead zones between neighbouring crystals should not exceed 0.6 mm and the material in front of the detector must not exceed 5% of a radiation length, which is equivalent to 4 mm of Al.

3.2 The PHOS PIN photo-diode

In collaboration with the PHOS project, the company AME¹ has designed and produced a PIN photo-diode optimized for the cross-section and spectral response of the

PHOS $PbWO_4$ crystal [3]. The PIN-diode has an active area of 17.1×16.1 mm² and is fabricated on n-type Si material of thickness 280 μm . The wafer specific resistivity is between 3000 and 6000 ohm-cm, which corresponds to a depletion voltage of $\sim 70V$. The dark current is ~ 5 nA. The PIN-diode response is optimized for the spectral region 400-500 nm in order to match the emission spectrum of the crystal, see Figure 3. The diode capacitance is ~ 150 pF.

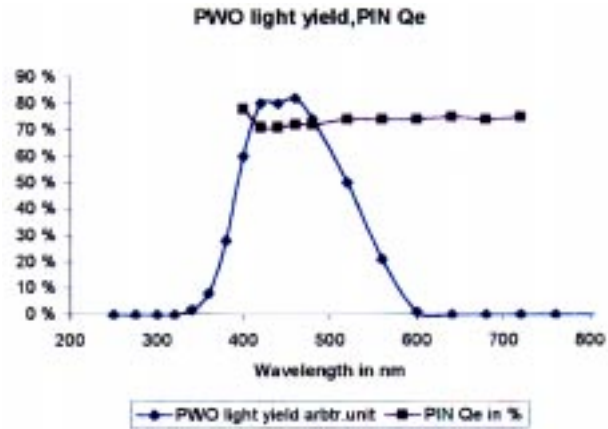

Figure 3. $PbWO_4$ emission spectrum and quantum efficiency of the PHOS D8501 PIN-diode.

3.3 Mounting of PIN-diode and preamplifier

The PIN-diode is mounted on a ceramic substrate 0.65 mm thick. On this substrate the diode is surrounded by a ceramic frame with outer dimensions 19.5×19.5 mm². The frame is 0.5 mm high with wall thickness 1.1 mm. The preamplifier PCB of dimension 20×20 mm² is attached to the back side of the frame using SMD technology, and bonded to the PIN-diode. The PIN-diode and the bondings to ground and preamplifier are protected by an optically transparent epoxy layer.

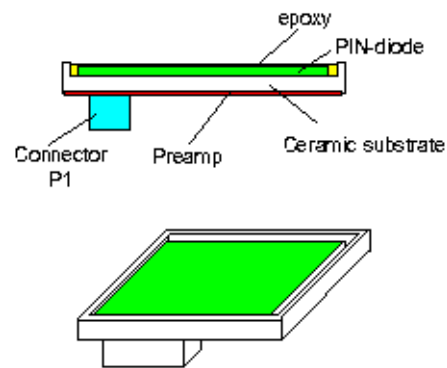

Figure 4. Mechanical mounting of the PIN-diode and preamplifier. The connector P1 carries power, bias voltage and preamplifier output.

¹ AME AS, POB 83, 3191 Horten, Norway

3.4 The preamplifier

For obtaining an ENC noise value of less than $600e^-$ with the large area PIN-diodes a PHOS specific preamplifier has been developed.

The circuit diagram is shown in Figure 5. The charge sensitive preamplifier (CSP) is an operational amplifier with the feedback capacitor C10 and with two JFETs (BF861A) T1 and T2 at the input. Using two JFETs in parallel gives the lowest noise for detector capacitance >100 pF, see section 3.6. The resistor R3 is direct current feedback and determines the fall time of the CSP's output signal which has been set to $200 \mu s$. The drain of T1 and T2 feeds the emitter of transistor T3, whose base potential determines the operation voltage of the JFETs. The operating currents of T1 and T2 are determined by the resistors R4 and R5. The characteristics of the JFETs determine the preamplifier's noise level and output pulse rise time. The CSP is supplied from $+12V$ and $-6V$. The power consumption is <200 mW. A detailed description is given in [4].

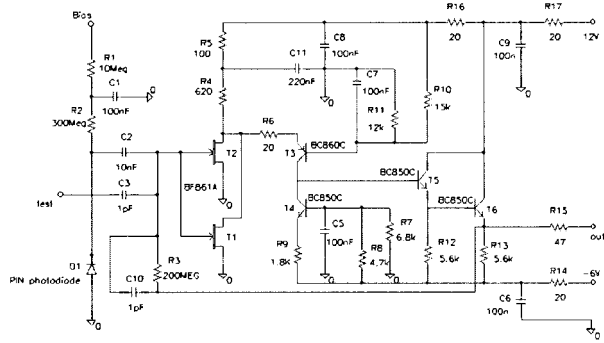

Figure 5. Circuit diagram of the preamplifier.

3.5 The shaper

A prototype shaper has been designed and built in discrete logic. The shaper circuit is shown in Figure 6. It comprises three amplification stages with a gain equal to 7 for each stage. The measured equivalent noise referred to the shaper input is $12 \mu V$ r.m.s. The input differentiation stage includes a 'pole-zero' compensation. Calculations for a PIN-diode with $C \sim 150$ pF and a leakage current <1 nA under cooling, gives a noise corner time constant of $6 \mu s$. For this value the optimum time constants of differentiation and integration are $3.36 \mu s$.

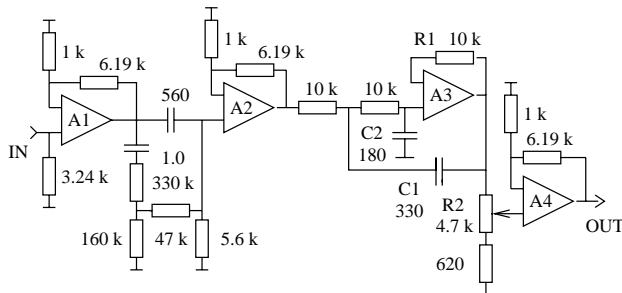

Figure 6. Circuit diagram of the PHOS prototype shaper.

3.6 Electronic noise measurement

The noise sources and characteristics of several preamplifier circuits and the preamplifier-shaper chain have been extensively studied, both experimentally and by SPICE simulations. Some of the results are presented in Figure 7.

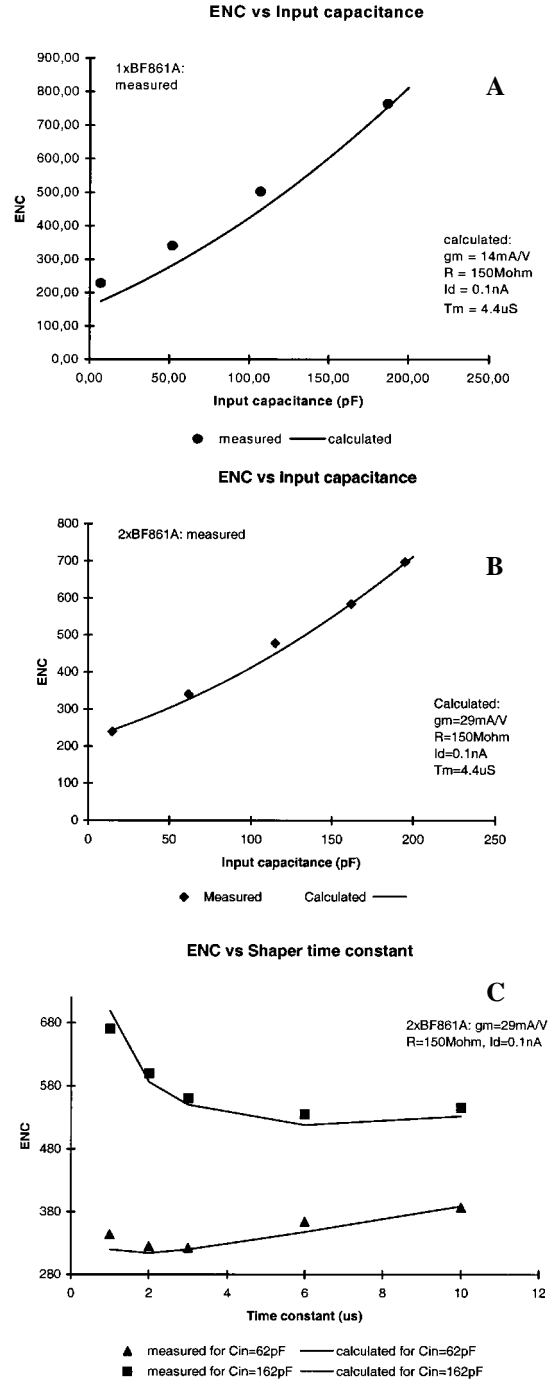

Figure 7. Measured and calculated ENC values. A: ENC vs. C_{in} for a single JFET circuit B: ENC vs. C_{in} for a dual JFET circuit C: ENC vs. shaping time

The PHOS preamplifier can be used with a wide range of PIN-diodes. As shown in Figure 7 the preamplifier with

one JFET in the input stage has the lowest noise levels for detectors with $C_{in} < 100$ pF. For detectors with $C_{in} > 100$ pF the circuit with two input JFETs in parallel gives the lowest noise. Figure 8 shows calculated curves for ENC vs. noise source and C_{in} for a dual JFET input stage. It is seen that the largest term is $1/f$ noise. This noise is mainly determined by the technology of making FETs.

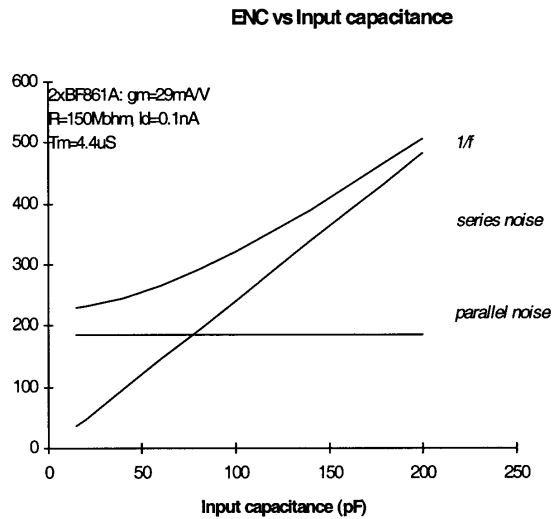

Figure 8. Calculated noise terms vs. input capacitance.

4. Integration of the photodetector

The mechanical integration of the $PbWO_4$ crystal and the PIN-diode with preamplifier is shown in Figure 9.

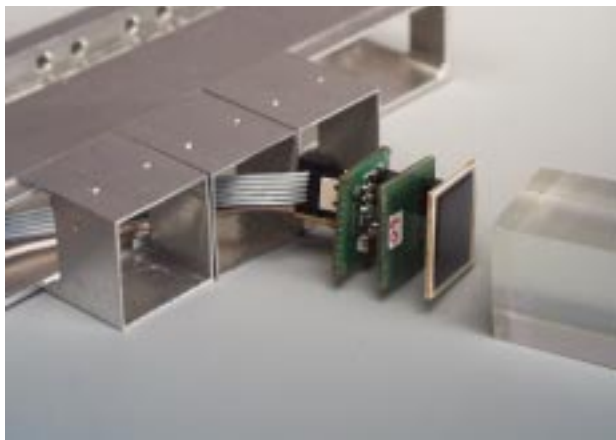

Figure 9. Prototype interconnection of the $PbWO_4$ crystal with PIN-diode, preamplifier PCBs and mechanical support. The PCB area is $20 \times 20 \text{ mm}^2$. Note that for the production version of the preamplifier will be mounted directly on the back side of the diode frame as illustrated in Figure 4.

The front side of the PIN-diode is glued onto the end-face of the $PbWO_4$ crystal with optically transparent glue¹. Each crystal is wrapped in White Tyvek to ensure maximum light collection efficiency and optical insulation be-

tween the crystals. The crystal pitch is 22.6 mm, which includes the wrapping and the crystal side cover. The construction of the crystal detector unit is shown in Figure 10. Eight crystal detector units are assembled in one row and constitutes the basic mechanical assembly unit, the strip unit. One PHOS module comprises 90×6 strip units.

A PHOS module is divided into a 'cold' and a 'warm' volume by thermoinsulation. The crystal units in the 'cold' volume are operated at -25 °C. The operating temperature is provided by forced cooling using a 1.2 propanedol-water coolant. The power dissipation inside the 'cold' volume from the preamplifiers is ~ 1 kW per PHOS module.

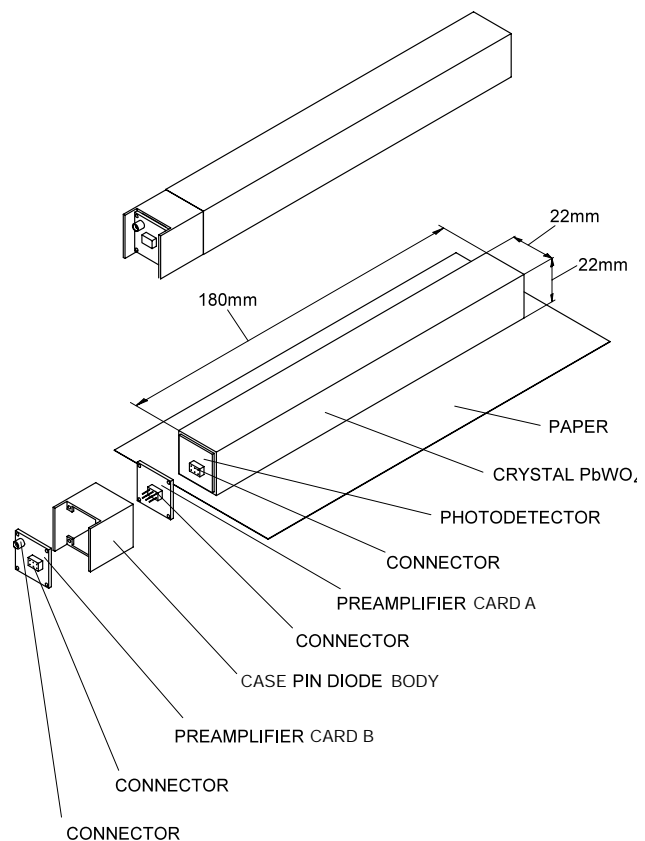

Figure 10. Construction of a crystal detector unit.

5. Laboratory and beam tests

The PHOS photo-detector R&D program was started in 1995. The first tests with a cooled crystal assembly were carried out in 1996, using a $10 \times 10 \text{ mm}^2$ PIN-diode and two prototype preamplifiers.

A laboratory measurement on a detector matrix of 64 units is presented in Figure 11. At -25 °C the measured ENC's are between $450\text{-}550 e^-$, well below the required value of $600 e^-$.

¹ Melt-Mount Quick-Stick, Cargille Laboratories, USA

Figure 12 shows the spectrum registered from a 180 mm long crystal in a 10 GeV electron beam. No significant tail from the ‘punch-through’ effect is seen.

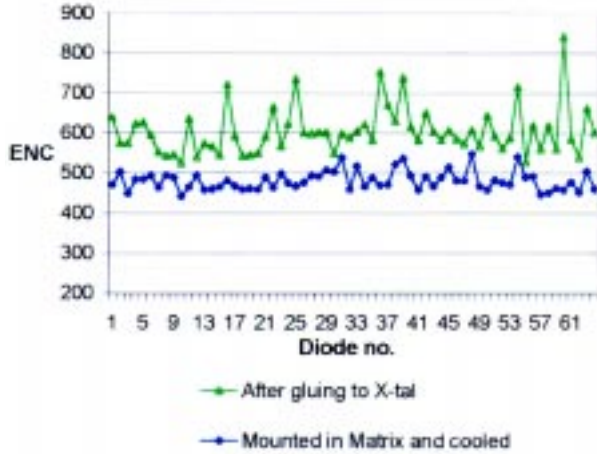

Figure 11. Noise measurements for PHOS beam tests 1998 on 64 crystals with full read-out chain: PIN-diode, preamplifier and shaper.

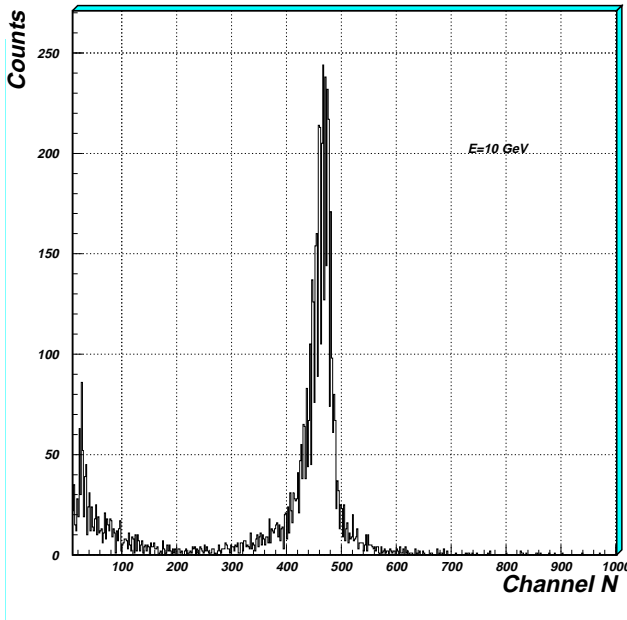

Figure 12. Spectrum from 10 GeV electrons in a PHOS 180 mm PbWO_4 crystal.

A summary of all beam test results are presented in Figure 13. They demonstrate that the energy resolution requirement defined in the ALICE Technical Proposal has been reached.

6. Read-out electronics

Integrated read-out electronics for the PHOS detector - shaper, ADC and front-end buffering - are under development.

7. Conclusions

The R&D program for the photodiode read-out of the PHOS electromagnetic calorimeter was started in 1995. Choosing PbWO_4 crystals of size $22 \times 22 \times 180 \text{ mm}^3$ as detection material, operated at $-25 \text{ }^\circ\text{C}$ to increase the light output yield, and coupled to specially developed PIN-diodes and preamplifiers, have led to a design that satisfies the spatial and energy resolution requirements for the PHOS electromagnetic calorimeter.

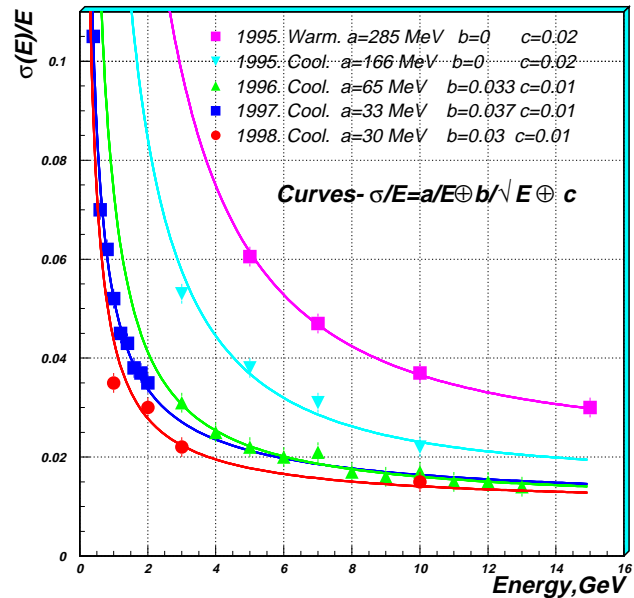

Figure 13. Summary of all beam test results for PHOS: experimental energy resolution vs. energy. The lowest curve represents the resolution requirement defined in the ALICE Technical Proposal [1].

8. References

- [1] ALICE Technical Proposal, CERN/LHCC 95-71. See also <http://www.cern.ch/ALICE/>
- [2] ALICE Technical Design Report of the Photon Spectrometer (PHOS), CERN/LHCC 99-4, ALICE TDR 2, 5 March 1999
- [3] D-8501 Custom Photo Diode for the PHOS Project, AME Data sheet, see also <http://www.ame.no/>
- [4] R. Rongved, A. Klovning, O. Maeland, I. Sibiriak, Preamplifier for ALICE-PHOS Project (CERN) - Calculation and Design, ALICE Note INT-99-11

Acknowledgement

The development of the PHOS PIN photo-diode and the preamplifier was funded by the Norwegian Research Council.