

# LASER ION SOURCE DEVELOPMENT FOR HEAVY IONS

H. Haseroth, H.Kugler, K.Langbein, A.Lombardi, W.Pirkl, R.Scrivens, T.Sherwood,  
A.Ster, A.Tambini, E.Tanke, CERN, Geneva, Switzerland

S.A.Kondrashev, V.Roudskoy, B.Yu.Sharkov, A.Shumshurov

Institute for Theoretical and Experimental Physics, ITEP, Moscow, Russia

L.Laska, K.Rohlena

Institute of Physics, Academy of Science of the Czech Republic, Prague, Czech Republic

J.Wolowski, E.Woryna

Institute of Plasma Physics and Laser Microfusion, Warsaw, Poland

K.N.Makarov, V.C.Roerich, Yu.A.Satov, A.E.Stepanov

Troitsk Institute for Innovation and Thermonuclear Investigations, TRINITI, Moscow Region, Russia

## Abstract

For light ions, Laser Ion Sources have already found their application (e.g. Dubna). At CERN a source for heavy ions with the final characteristics  $Pb^{25+}$ , with current of 5 - 10 mA, a pulse length of 5 - 6  $\mu s$ , a normalised 4 x rms emittance of 0.2 - 0.4 mm\*mrad, is under development. Topics like the required laser energy and performance, the ion beam transport and the acceleration are discussed. The different phases of the realisation of this source and its status are presented.

## Introduction

In the late 80s the concept of a Lead-Ion Accelerating facility at CERN was under discussion, so laser ion sources became of interest. In 1988 a 50 J carbon dioxide laser was acquired to assemble an experiment (Fig.1). In 1991 first results were reported [1]:  $Pb^{26+}$  was observed, a group of ions of charge states around 20+ providing current densities of 1 mA/cm<sup>2</sup> was obtained. From the start, most of the studies were carried out together with ITEP, involved in plasma physics and a branch of the Kurchatov Institute at Troitsk, TRINITI. There, lasers 2-3 times higher in energy became available, and the generation of Pb ions around charge 25+ at current densities of 0.3 mA/cm<sup>2</sup> per charge state, was observed.

At the beginning of 1994, Al ions, generated in the Laser Ion Source (LIS), were accelerated in a radio frequency quadrupole (RFQ). Currents of more than 1 mA per charge state of  $Al^{9+}$  to  $Al^{11+}$ , were observed [2], the pulse length was several  $\mu s$ . This achievement, together with the results with heavy ions, encouraged us to direct our development work towards a source capable of providing ions for the Large Hadron Collider (LHC)[3]. The scheme retained in the LHC feasibility study is based on an ECR source and a low energy storage ring. The approach based on a LIS is pursued as an alternative solution.

In this report a possible configuration of a source and a pre-accelerator is sketched. Attention is focused on some key elements. The different phases of realisation of a complete device are described. In this context, the present experiment and its preliminary results are analysed. Building such a device is a matter of many years. New technologies may in

the future lead to solid state lasers and sources, providing sufficient ion yield at much higher charge states. How we intend to cope with these trends is discussed briefly in the section on recent developments.

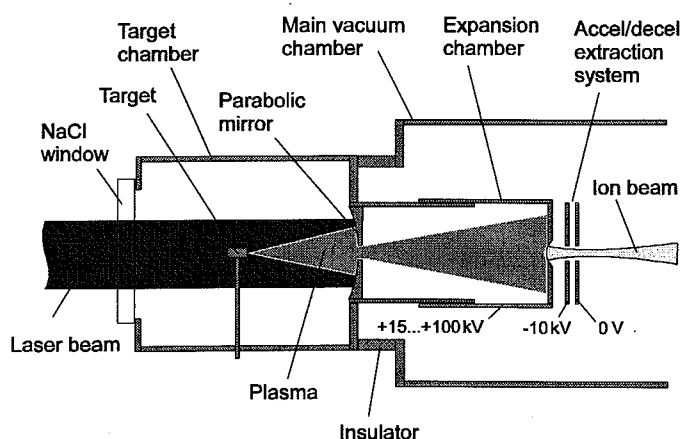

Fig.1. Configuration of a Laser Ion Source

## Requirements from a Source

For heavy ion experiments, the LHC demands a luminosity  $L = 3.2 \cdot 10^{24} \text{ cm}^{-2} \text{ s}^{-1} / \text{ bunch}$ . The machine is designed to obtain this value with  $9.4 \cdot 10^7$  ions / bunch at a normalised 1 rms emittance of  $\epsilon_n = 1.5 \cdot 10^{-6} \text{ m} \cdot \text{rad}$ .

The LHC filling scheme described in [4] and the present performance of the different machines lead to our target value at the extraction electrodes of the LIS:

$$1.4 \cdot 10^{10} \text{ ions of } Pb^{25+} \text{ in a pulse of } 5.5 \mu s,$$

$$\epsilon_n(\text{rms}) = 0.05 \cdot 10^{-6} \text{ m} \cdot \text{rad}, \text{ every } 1.2 \text{ sec.}$$

## A Possible Configuration of a Source with Pre-accelerator

The configuration should consist of

- 1) A laser of 100 J.
- 2) A photon transport system of sufficient length to decouple the laser from the target.
- 3) A target capable of producing  $10^5$  shots without replacement.
- 4) An extraction system for accelerating  $Pb^{25+}$  to 9.6 keV/u.

- 5) A low energy beam transport channel (LEBT).
- 6) An RFQ, accelerating  $Pb^{25+}$  from 9.6 to 250 keV/u.
- 7) A beam line with switch yard in Linac3 [5].

### Key Elements

At present, design concentrates on (i) a new laser and (ii) the construction of the ensemble "target - illumination - ion extraction".

The results of the present experiment should later allow the choice of the definitive LEBT (e.g. a multi element filter line or a straight line (e.g. 2 solenoids)).

#### (i) The Laser

The present 50 J laser, well suited for many of the preparatory experiments, fails as final laser as repetition rate, energy per pulse and stability from shot to shot are too low.

In experiments and plasma simulations, the charge state with the highest abundance as function of laser power density and focal spot size was established (see Fig. 2 [6]). Current density was found to scale linearly with energy.

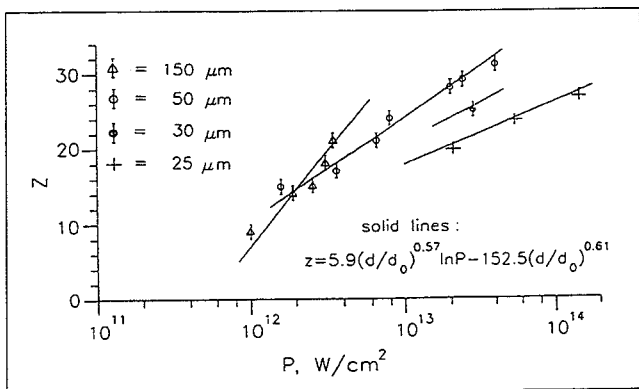

Fig.2. Charge-State as Function of Power Density ( $d_0 = 50 \mu m$ ).

Based on these results and keeping the aperture of the extraction electrode sufficiently small (emittance is a function of the diameter), laser energy and plasma expansion length could be estimated [7]. The set of data, scaling laws and the result are summarised in Table 1.

A very important observation was that from the total laser energy only the photons reaching the target area within the first 30 ns and the Airy spot, contribute to the ion yield.

The energy within these constraints is termed useful energy ( $E'$ ). In a free-running laser,  $E'$  can become as low as 25 % of the total energy. The non-useful energy contributes, however, to the damage of the target and contamination of the optical elements.

Total Energy  $E_{tot} = 80 J$ ,  
 50% in pulse of 30 ns, 50% in spot with  $d = 100 \mu m$   
 $\rightarrow$  useful  $E' = 20 J$ ,  $\rightarrow P = 8 * 10^{12} W/cm^2$   
 observed:

$z$  with highest abundance: 25

at  $l = 3.5 m$ ,  $\tau = 8 \mu s$  for ions around  $z = 25$ ,

at  $l = 3.0 m$ ,  $j_1 = 1.2 mA/cm^2$  in aperture  $\varnothing = 34 mm$   
 relations, leading to the set of "key data":

$\tau \propto l$ ,  $j \propto l^{-3}$ ,  $j \propto E'$ ,  $j_{25+} = 15\%$  of  $j$ .

key data:

with a laser of  $E' = 80 J$  in 30 ns, focused to  $d' = 200 \mu m$ ,  
 a current density  $j_{25+} = 1.12 mA/cm^2$  at  $l = 2.6 m$  should  
 be obtained.

The pulse should last  $\tau = 6 \mu s$ . Through the extraction  
 aperture  $\varnothing$ , a current of 10 mA should flow.

$P$  = power density,  $l$  = plasma expansion length,  $d, d'$  =  
 spot diameter of central diffraction pattern of laser beam  
 at the target with intensity contour  $I = 1/e * I_{peak}$ ,  
 $j_1$  = current density of group of charge states around 25+

Table 1 Estimation of Laser Energy and Plasma Expansion Length for the Final Set-Up, based on Experimental Data

Another characteristic of a free running laser is the variation of pulse form from shot to shot due to excitation of different longitudinal modes (Fig.3). This effect is considered responsible for most of the ion current variation ( $\pm 25 \%$ ).

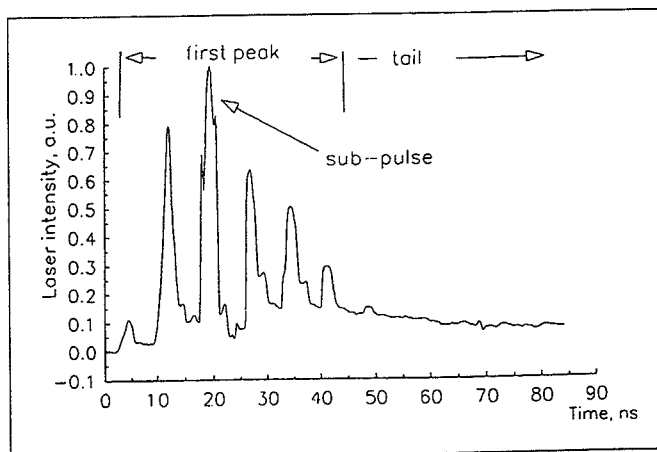

Fig.3. Pulse Shape of a Self locking Laser.

These problems may be solved by using a laser system of a master oscillator and a power amplifier (Fig.4), working in single transverse mode ( $TEM_{00}$ ) and single frequency.

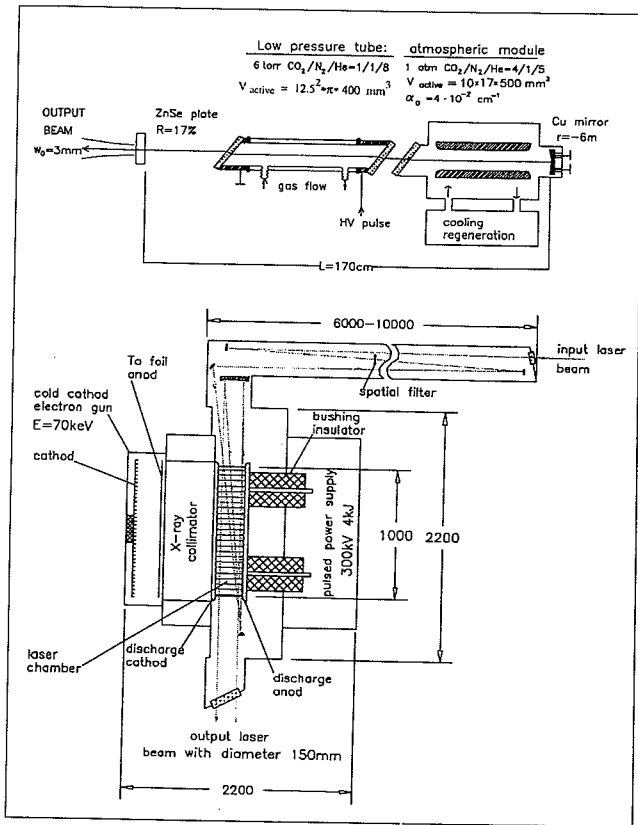

Fig. 4. CO<sub>2</sub> Laser Master Oscillator and Power Amplifier.

Concentrating all the laser energy in the first 30 ns and choosing an appropriate optical design of the laser mirrors, is supposed to lead to a laser device with 80% of useful energy. The design of a 100 J laser has started. Two characteristics that are a strong challenge to the designer and manufacturer are the pulse repetition rate of 1 Hz and the demand of intervention free operation for  $2 \times 10^6$  shots.

(ii) The ensemble "target-expansion-extraction-target illumination"

Another element in detailed design, is the target, expansion area, extraction area and illumination system. The target should withstand at least  $10^5$  shots before replacement. Based on 300 laser shots per LHC filling cycle every 8.5 hrs, this target would allow more than 100 days of uninterrupted operation. However, in sessions of machine development, when continuous 0.8 Hz operation is needed, this target will be used in less than 2 days.

Results from experiments on multi-shots per target position with the high energy lasers at TRINITY show stable ion production from 20 shots per position. With a crater diameter of 3 mm, a target surface of more than  $400 \text{ cm}^2$  must be available. This demands a new configuration shown in Fig.5. The target will be a rotatable cylinder, fine adjustment in the plane normal to the laser beam and in its axis will be possible. The ensemble is modular such that geometry can be changed by replacement of tubes.

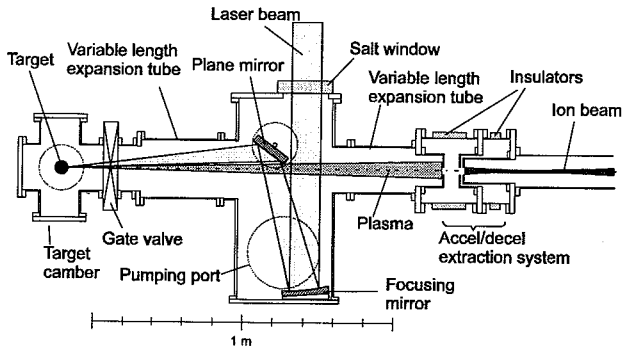

Fig.5. Source Ensemble under Design

### Phases Towards a Complete Device

The completion of the LIS for the LHC can be seen in 4 phases:

- 1) Integration of the laser ion source in an accelerator environment, matching of the different beam parameters with respect to beam brightness.
- 2) Demonstration that this device can be tamed with respect to plasma instabilities.
- 3) Device scaling to "operational" dimensions
- 4) Integration in Linac3.

We are in phase 1. Next year we will enter phase 2, when a master oscillator will be installed and the present 50 J laser converted to an amplifier.

In parallel, the design of the final amplifier will proceed, construction and integration of the new source ensemble into the experiment is envisaged. Up-grade of the final LEBT may become necessary, and the design of a mean energy beam transport (MEBT) should start.

Phase 3, should see the up-grade of the RFQ to 250 keV/u for Pb<sup>25+</sup>, and the integration of the 1 Hz - 100 J laser system.

Phase 4 is still far future. Getting the beam into the MEBT of Linac3 will demand a switchyard.

### Present Experiment, Preliminary Results

A schematic diagram of the set up is shown below.

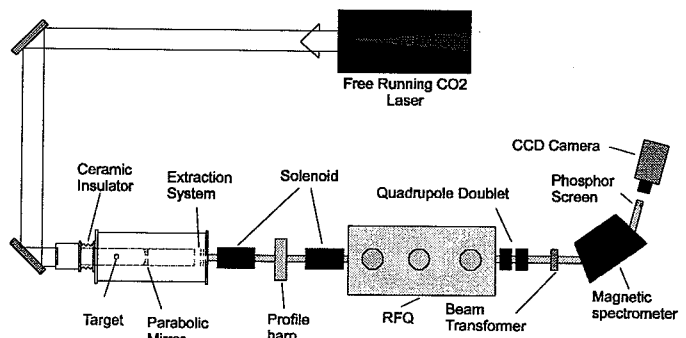

Fig.6. Schematic Diagram of Experimental Set up

The experiment is described in detail in [8], shown in Fig.6. The main characteristics of the laser can be found in Table 4. 50 J is the nominal energy per pulse. The laser parameters have been optimised with respect to ion yield. Under these conditions, 30 J is drawn. About 7.5 J contribute to the yield of Ta<sup>16+</sup> - Ta<sup>24+</sup> ions. A power density  $P = 1.6 * 10^{13} \text{ W/cm}^2$  is achieved. At present we use Tantalum. Ta<sup>16+</sup> is, in its charge to mass ratio, very similar to Pb<sup>18+</sup>. It is preferred to Pb due to less contamination of the target area and longer life time (less cratering of the target). Later Pb<sup>18+</sup> will be used as well.

The relative abundance of ions, passing the extraction electrode, is shown in Fig. 7.

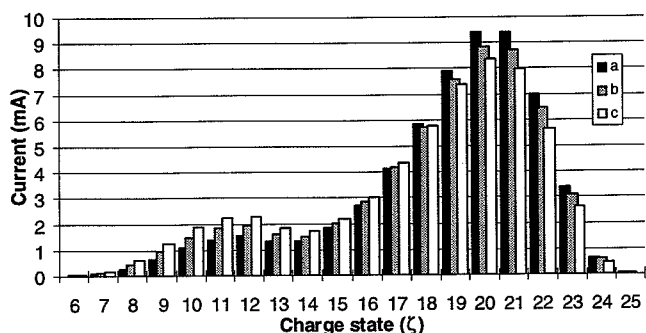

Fig. 7. Abundance of Ions for the Unaccelerated Plasma, a)  $\gamma$  independent of charge state, b)  $\gamma$  scaling with kinetic energy, c)  $\gamma$  proportional to charge state.

Measurements of the secondary emission coefficients  $\gamma$  for the detector material, CuBe, bombarded by heavy ions, are still missing for ions with mean energies of 2.5 keV/q. For these energies the two mechanisms for the generation of secondary electrons, (i) due to kinetic energy and (ii) due to potential energy seem to overlap. The three distributions in the graph indicate the "uncorrected" measurement, and two corrected ones. The true distribution will be somewhere in between b) and c).

The LEBT, consisting of two solenoids, had to be designed on the basis of preliminary parameters, measured under conditions very different from the final set-up; TRACE was used for beam simulations. Now, the program PATH [9,10] (based on TURTLE) which allows multi-particle tracing and the representation of magnetic elements by field tables, will be used to optimise the beam transfer. The RFQ is described in [11,12]. Some characteristics are given in Table 2.

Design ion:	charge 18+, mass 208 a.m.u.
Input energy:	6.9 keV/u
Output energy:	100 keV/u
Transmission:	90%
Current per charge-state	10 mA
Acceptance:	300 mm*mrad, total, unnorm.
Longitudinal emittance :	12 deg*keV/u , 1 rms value

Table 2 Main characteristics of the RFQ

Its performance measured with protons is close to design. The feared sparking from plasma photons entering the RFQ, occurs very unfrequently. This RFQ is designed for peak currents of 30 mA, 19 mA are available now. To test the RFQ to its full performance, the present charge to mass ratio of 0.11 will be decreased to 0.086, working with Ta<sup>16+</sup> or Pb<sup>18+</sup>.

The performance of the experiment is given in Table 3. The LEBT is at present the weak element in the chain. Matching of the extraction to the RFQ is yet not achieved.

pos.	mean current in 5 $\mu$ s (mA)	$\epsilon$ , 4 x rms (mm*mrad)	full $\Delta E/E$	remarks
1	60, (peak 80)			$\varnothing = 30 \text{ mm}$ , $l = 1 \text{ m}$ , $U = 60 \text{ kV}$ $I_{\text{max}} = 100 \text{ mA}$ at $l = 0.9 \text{ m}$
2	60	250		18 charge-states in 3-8 $\mu$ s max: Ta20+
3			0.11 0.025	no modulation 60-65 kV, modul.
4	10, (peak 19)			$\varnothing = 6.5 \text{ mm}$ 6 charge-states
5	2.0, (peak 9) Ta20+ : 1			pulse length 2 $\mu$ s
6		22	0.05	5 charge-states Ta 18+ - 22+

Table 3 Summary of Preliminary Results

The positions are 24 mm after extraction (1), 79 mm after extraction (2), spectrometer after LEBT (3), RFQ in-input plane(4), 90 mm after RFQ (5), behind spectrometer after RFQ (6). U = extraction voltage,  $\varnothing$  = aperture of Faraday cup, l = plasma expansion length.

### Recent Developments

Today, CO<sub>2</sub> lasers with high energies, at high pulse rates, are field proven. Energies and pulse characteristics to provide the needed particles from the target, are known.

In the past, solid state lasers in the energy range of 20 - 100 J with pulse rates of 1Hz were not available. The problem was heat dissipation (solved in CO<sub>2</sub> lasers by circulating gas stream). Diode pumped lasers, where the pumping efficiency is much higher than with flash lamps may break this limitation and performance to cost ratio may become more favourable for solid state lasers than for gas lasers.

In parallel to this development, it could be shown that ions with charge states, much higher than 20-30 (Ta<sup>55+</sup>, Pb<sup>51+</sup>), can be obtained [13] at shorter pulse duration and laser wave lengths, 10 times shorter than for CO<sub>2</sub>, yet with low particle yield. An ion linac without a stripper may become a reality in the future.

To follow these developments as tightly as possible, our collaboration has been enlarged.

A brief overview on lasers, available in this collaborations is given in Table 4.

Institute	lasers
CERN	CO <sub>2</sub> , 50 J, 10.6 μm, 50 ns FWHM, 0.05 Hz free running oscillator (FRO)
ITEP	CO <sub>2</sub> , 10 J, 10.6 μm, 50-60 ns, fro, 1 Hz CO <sub>2</sub> , 20-40 J, 10.6 μm, 50-60 ns, 0.07 Hz
TRINITI	CO <sub>2</sub> , 100 J, 10.6 μm, 30 ns, fro, 0.02 Hz other, master - oscillator / power amplifier systems, CO <sub>2</sub> , max 300 J
ASCR Prague	Iodine photodissociation, 50 J, 1.315 μm, 300 - 500 ps, also higher harmonics of 2nd, 3rd order, then 25 J, time between shots: several minutes, master oscillator / power amplifier
IPPLM Warsaw	Nd:glass, 15 J, 1.06 μm, 1 ns, 2*30 J, 1.06 μm, 0.5 ns Nd:glass, 2 J, 1.06 μm, 1-2 ps, all systems master oscillators / power amplifier time between pulses 20 minutes

Table 4 Lasers at the Collaborating Institutes

### Conclusion

Reaching nearly 20% of the finally required amount of ions for Pb<sup>25+</sup> for the heavy ion Tantalum, see Table 5, is encouraging.

However, much attention will still have to be spent on laser performance, particle transmission from the extraction electrodes to the RFQ and lay-out and construction of the ensemble target - extraction - illumination to reach the required source performance.

The experimental set-up with its RFQ and the numerous beam diagnostic devices, should allow us to evaluate the beam brightness.

1 = year, 2 = ion, 3 = particles (10exp9), 4 = pulse length (μs), 5 = transverse rms emittance, normalised (mm\*mrad), 6 = longitudinal rms emittance (deg\*keV/u), 7 = kinetic energy (keV/u), 8 = β (10exp-2)

1	2	3	4	5	6	7	8
1994	27 Al 10+	< 2	3			140	1.73
1996	181 Ta 20+	1.6	2	0.08		100	1.47
?	208 Pb 25+	7-8	5	0.07	13	250	2.32

Table 5 Parameters at Out-let of the RFQ

### Acknowledgements

Maintaining and improving of operational systems has become the main work load of the permanent staff, steadily

shrinking. We would like to thank all those who despite their increasing daily duties find the time to help us at this experiment: the teams, taking care of magnets, mechanical elements, radio frequency, survey and the vacuum equipment.

### References

- [1] Y.Amdidouche, H.Haseroth, A.Kuttenberger, K.Langbein, J.Sellmair, B.Sharkov, O.Sharmaev, T.R.Sherwood, B.Williams "The Laser Ion Source Test Facility at CERN" Int. Conf. on Ion Sources (ICIS), Bensheim, Germany, September 1991
- [2] J.Collier, H.Haseroth, A.Kuttenberger, K.Langbein "Acceleration of light ions from a laser source in a four vane radio frequency quadrupole", Proceedings of the 6th Int. Conf. on Ion Sources (ICIS), Rev. Sci. Instr. Vol. 67, No.3, Part II, March 1996
- [3] The LHC Study Group "The Large Hadron Collider" CERN/AC/95-05 (LHC), 20 October 1995
- [4] K.-H. Schindl "The LHC Ion Injector Chain (Laser Ion Source)", in "Laser Ion Source Developments", Proceedings of the PS Performance Day (PPD'96), PS/PA/Note96-06(PPC)
- [5] D.J.Warner "The Heavy Ion Linac for the CERN Lead Ion Facility" Proceedings of the 1994 International Linac Conference, August 1994, Tsukuba, Japan, vol2, 654
- [6] S.V.Homenko, K.N.Makarov, V.K.Roerich, Y.A.Satov, A.E. Stepanov, B.Yu.Sharkov "Investigation of Highly-charged heavy ion generation in CO<sub>2</sub> laser produced plasma" 24th European Conference on Laser Interaction with Matter, Madrid, June 1996
- [7] Institute for Laser Physics (ILP) "Final report on Investigations of highly-charged heavy ion generation, CO<sub>2</sub> laser ion source design", Troitsk 1995
- [8] M. Bourgeois, G.Hall, H.Haseroth, S.Kondrashev, H.Kugler, K.Langbein, A.Lombardi, K.Makarov, W.Pirkl, Y.Satov, R.M.Scrivens, B.Sharkov, A.Shumshurov, A.Ster, A.J.Tambini, E.Tanke "High charge-state ion beam production from a laser source", this conference
- [9] J.Farel, PATH - A Lumped Element Beam Transport Simulation Program with Space Charge. Lecture Notes in Physics, W.Busse, R.Zelazny, Springer Verlag 1984
- [10] A. Ster "PATH 1.0 PC version, adaptation and new features", PS/HI/Note 96-04, Feb 1996
- [11] P. Bourquin, W. Pirkl, H.H. Umstätter "RF and constructional issues in the CERN LIS RFQ", this conference
- [12] A.M. Lombardi, E. Tanke "Design and Beam Tests of an RFQ to accelerate a Lead Ion Beam from a Laser Ion Source", this conference
- [13] K. Rohlena, B.Kralikova, J.Krasa, K.Masek, T.Mocek, M.Pfeifer, J.Skala, P.Strka, J.Farny, P.Parys, J.Wolowski, E.Woryna, W.Mroz, A.Golubev, B.Sharkov, A.Shumshurov, J.Collier, H.Haseroth, K.Langbein, "Laser Sources of Multiply Charged Heavy Ions" Proceedings of BEAMS'96 Conference, Prague, June 1996, to be published