

AC

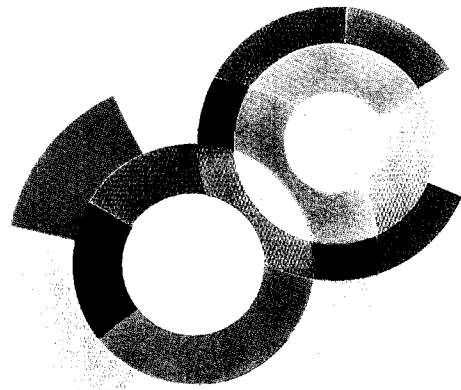

# SERVICE DE PHYSIQUE DES PARTICULES

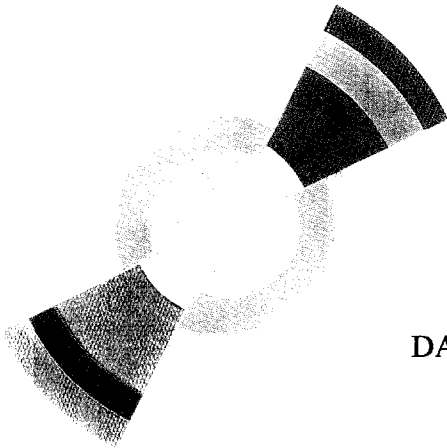
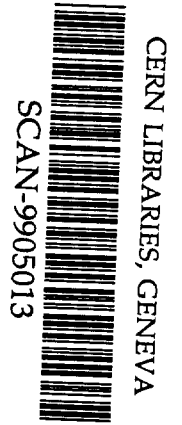

DAPNIA/SPP 99-08

March 1999

NA48 : DIRECT CP VIOLATION IN  $K^0$  DECAYS

**Julien Cogan**

# DAPNIA

*Talk given at the International Workshop on CP violation in K,  
Tanashi, Tokyo (Japan), December 18-19 1998*

# NA48: direct CP violation in $K^0$ decays

Julien Cogan\*  
*CEA/SACLAY-DAPNIA/SPP*  
*91191 Gif sur Yvette Cedex, France*

December 18<sup>th</sup>, 1998

\*On behalf of the NA48 Collaboration: Cagliari, Cambridge, CERN, Dubna, Edinburgh, Ferrara, Firenze, Mainz, Orsay, Perugia, Pisa, Saclay, Siegen, Torino, Vienna and Warsaw.

## Abstract

The CERN NA48 experiment [1] aims to determine the direct CP violation parameter  $\text{Re}(\varepsilon'/\varepsilon)$  with a precision of  $2 \times 10^{-4}$ . The experiment has recorded about 650000  $K_L \rightarrow \pi^0\pi^0$  decays during 1997 and about 3 times as much in 1998. The Na48 apparatus is described and the current status of 1997 data analysis is reported here.

---

\*electronic address: [cogan@hep.saclay.cea.fr](mailto:cogan@hep.saclay.cea.fr)

# 1 The NA48 measurement

## 1.1 Method

Whereas indirect CP violation (in the mass mixing) is well established in the kaon system, direct CP violation (in a decay amplitude) is still an open issue. The latter is characterized in the Standard Model by a non-zero value of the parameter  $\varepsilon'/\varepsilon$ .

The two precision measurements of  $\text{Re}(\varepsilon'/\varepsilon)$  available so far are in poor agreement: the CERN experiment NA31 has reported  $(23 \pm 6.5) \cdot 10^{-4}$  [2] while E731 at Fermilab has measured a value compatible with zero:  $(7.4 \pm 5.2 \pm 2.9) \cdot 10^{-4}$  [3].

$\text{Re}(\varepsilon'/\varepsilon)$  can be related to the short- and long-lived kaon into two charged or two neutral pion decay amplitudes by the following relation:

$$R = \frac{\Gamma(K_L \rightarrow \pi^0 \pi^0)}{\Gamma(K_S \rightarrow \pi^0 \pi^0)} / \frac{\Gamma(K_L \rightarrow \pi^+ \pi^-)}{\Gamma(K_S \rightarrow \pi^+ \pi^-)} \approx 1 - 6 \times \text{Re}(\varepsilon'/\varepsilon)$$

The NA48 experiment aims to determine  $\text{Re}(\varepsilon'/\varepsilon)$  with an accuracy of  $2 \times 10^{-4}$  by measuring the double ratio R. To avoid biases when comparing the different decays, NA48 collects the four modes concurrently and from the same fiducial volume using almost co-linear  $K_L$  and  $K_S$  beams distinguished by tagging the proton producing the  $K_S$  particle. The charged and neutral pion modes are identified by high resolution detectors providing excellent background rejection. In addition, to compensate for the natural difference between  $K_L$  and  $K_S$  lifetimes,  $K_L$  decays are weighed in the analysis to make the longitudinal z vertex distribution identical for  $K_L$  and  $K_S$  so as to cancel out acceptance effects as a function of z in the double ratio.

## 1.2 $K_L$ and $K_S$ simultaneous beams

The two kaon beams are produced by interaction of 450 GeV protons with two beryllium targets, one radiation length thick. To build the  $K_L$  beam, an intense proton beam ( $\sim 10^{12}$  /s) supplied by the CERN-SPS, strikes a first target. A neutral beam is selected at a production angle of 2.4 mrad and is collimated along the z axis. It travels in a 120 m long beampipe where all the  $K_S$  decay.

A small fraction of the protons which did not interact in the  $K_L$  target is deflected by a bent crystal [4]. The resulting proton beam ( $\sim 10^7$  /s) is used to create the  $K_S$  beam. It is steered on the  $K_L$  beam axis and is sent on the 2<sup>nd</sup> target located 7.2 cm above the  $K_L$  beam. The second neutral beam, selected at 4.2 mrad, is defined by collimation over a length of 6 m so as to converge towards the detector at an angle of 0.6 mrad with respect to the  $K_L$  beam. The two beams emerge from their respective last collimator at the same longitudinal position and are entering a common decay volume of about 120 m long. They are observed over the same effective length corresponding to a few  $K_S$  proper lifetimes. Due to the difference between the  $K_L$  and  $K_S$  lifetimes and the suppression of  $K_L \rightarrow 2\pi$  decays, the  $K_L$  component of the short neutral beam is negligible. The targeting angles

of the two beams have been chosen such that the  $K_L$  and  $K_S$  energy spectra are quite similar between 70 GeV and 170 GeV, the kaon energy range used in the analysis.

Two important subdetectors are used on the  $K_S$  beam line. A detector consisting of two ladders of scintillation foils, called the tagger, measures the time of the protons impinging on the  $K_S$  target to allow for  $K_S$  identification, (see 2.1). Each foil sees only a part of the proton beam section to cope with high counting rates. The measured time resolution for a single counter is 180 ps and its double pulse separation is better than 5 ns. The AKS anti-counter is placed few centimeters downstream of the last  $K_S$  collimator to define precisely the beginning of the fiducial decay region (see 2.3). The AKS consists of an iridium crystal convertor followed by a system of plastic scintillators.

### 1.3 Detectors

The evacuated decay volume is closed by a thin kevlar window and is followed by the NA48 detector. It is traversed by a beam pipe to transport the neutral beams towards a dump. The NA48 detector has been designed to identify neutral kaon decays with excellent energy, position and time resolutions at rates exceeding 1MHz. The main components of the detector are described in this section.

Charged decays are reconstructed using a magnetic spectrometer contained in a 22 m long tank filled with helium. The magnetic spectrometer consists of a central dipole magnet with a field integral equivalent to a transverse momentum kick of 256 GeV/c, and two sets of two large drift chambers on each side. Each chamber contains 8 planes of 256 parallel sense wires. The planes are staggered by pairs and oriented in four directions orthogonal to the beam axis [6]. The momentum resolution, evaluated with an electron beam at 25 GeV and 100 GeV is:  $\sigma(P)/P = (0.48 \oplus 0.009 P[\text{GeV}/c])\%$ . The mass resolution on the reconstructed  $\pi^+\pi^-$  events is about 2.5 MeV/c<sup>2</sup>.

The precise time reference of  $K_{L,S} \rightarrow \pi^+\pi^-$  decays is provided by the charged hodoscope. It is formed by two planes of 64 scintillator counters, one horizontal and one vertical. The time resolution of an individual counter is better than 400 ps yielding thus a time resolution better than 200 ps for a two-pion event.

Photons resulting from neutral pion decays in  $K_{L,S} \rightarrow \pi^0\pi^0$  are detected in a quasi-homogeneous liquid krypton (LKr) calorimeter with a longitudinal electrode structure pointing towards the decay region located about 110 m upstream. The calorimeter is segmented into 13212 cells of  $\sim 2 \times 2$  cm<sup>2</sup> cross section to ensure good granularity. Above 25 GeV, both horizontal and vertical positions are evaluated with a resolution better than 1 mm. The time resolution for a single photon is of the order of 200 ps. The energy resolution is better than 1% with a constant term of  $\sim 0.6\%$  yielding a 1.1 MeV/c<sup>2</sup> resolution on the reconstructed  $\pi^0$  mass. The calorimeter response was found to be linear within 0.2% in the 5 to 100 GeV range using electrons from  $K_{e3}$  decays [7].

A scintillator fiber hodoscope, embedded in the Lkr structure, is used to provide a minimum bias trigger for neutral trigger efficiency measurements.

A hadronic calorimeter made of Fe and plastic scintillator sandwiches measures the

hadronic shower leakage from the LKr calorimeter. It is used as part of the first level charged trigger.

Three layers of scintillator counters with 80 cm of iron in front of each are used to reject muons from  $K_{\mu 3}$  decays.

## 1.4 Triggers

The charged trigger is a two-level trigger. The Level one (L1) requires the coincidence of hits in two opposite quadrants of the charged hodoscope and total energy in the two calorimeters above 30 GeV. The Level two (L2) performs a fast tracking in the spectrometer. Hits in the two staggered planes of each view are combined by a hardware device to build coordinates which are then used by a farm of processors to compute the vertex and the invariant mass of two tracks [8].

In 1997, the L2 performed a reduction of about 50 on the  $\sim 70$  kHz input rate. The dead time ( $\sim 1\%$ ) induced by the Level 2 was recorded on an event by event basis so as to be applied to neutral events in the analysis and therefore introduced no bias on the  $\text{Re}(\varepsilon'/\varepsilon)$  measurement. The combined L1-L2 efficiency was measured to be  $\sim 91\%$  and showed no significant  $K_L / K_S$  difference at the per mille level.

The neutral trigger is a fully pipelined software trigger operating at 40 MHz. The information from the calorimeter is reduced to 64 rows and 64 columns after summing horizontally and vertically the analogue response of  $2 \times 8$  cells. From these projections, the neutral trigger computes and cuts on the number of in-time clusters, on total energy in the detector, on energy center of gravity and decay vertex position. It reduces the 1 MHz input rate to 2.5 kHz while its efficiency is larger than 99% [9].

## 2 1997 data

The first  $\text{Re}(\varepsilon'/\varepsilon)$  data taking period took place from September to October 1997. It was the first time the liquid krypton calorimeter was instrumented with the full read-out electronics. The e.m. calorimeter was operated with a reduced high voltage due to capacitor problems. This induced a small space charge effect ( $< 0.5\%$ ) and a 20% increase of the electronic noise. In addition, one column, 4 cm wide, remained unconnected to HV. These problems were cured during the 1997-98 winter shutdown. The experiment ran for 42 days at about  $2/3$  of nominal beam intensity. 25 Tbytes of data were written on tape at an average read-out rate of  $\sim 80$  Mbytes/s. At the end of the data taking period a sample of about 650 000 useful  $K_L \rightarrow \pi^0 \pi^0$  events, which represents the statistically limiting mode, was recorded.

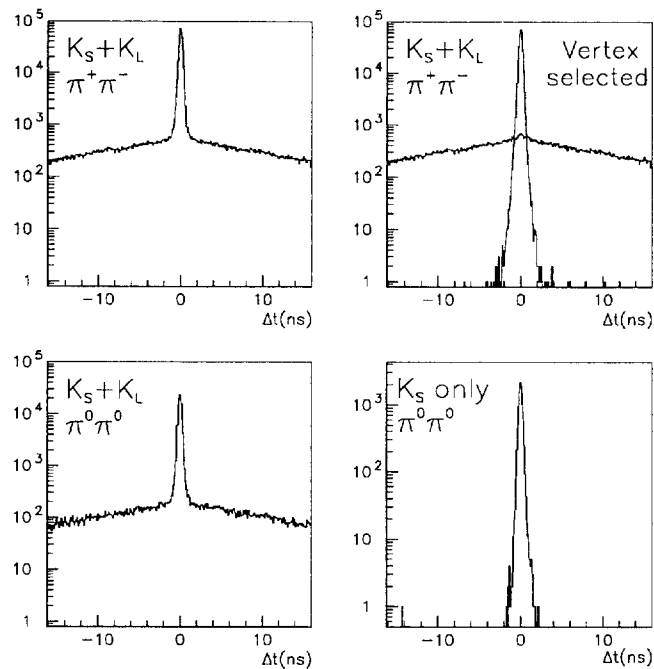

Figure 1: Proton tagging

## 2.1 $K_S$ Tagging

The  $K_S$  and  $K_L$  decay products are detected concurrently. To compute the double ratio  $R$ , the origin ( $K_S$  or  $K_L$ ) of the 2-pion decays has to be determined. For this purpose, the protons upstream of the  $K_S$  target are detected in the tagger and  $K_S$  are distinguished from  $K_L$  by looking at the time coincidence between the 2 pions in the detectors and a proton in the tagger. The decay time is given by the charged hodoscope for the  $K_{L,S} \rightarrow \pi^+\pi^-$  decays and by the e.m. calorimeter for the  $K_{L,S} \rightarrow \pi^0\pi^0$  decays. An event is called  $K_S$  if there is a proton in time with the decay within  $\pm 2$  ns, otherwise the event is considered as  $K_L$  (see Fig 1).

Tagging inefficiencies arise when the proton is missed or lies outside the coincidence window. They lead to  $K_S \rightarrow K_L$  transitions. The coincidence window is such that tagging inefficiencies are kept at a low level (few  $10^{-4}$ ). The double ratio is then only sensitive to the difference of inefficiency between charged and neutral modes. For the charged decays, the good vertex resolution allows to locate the origin of the decay and therefore to measure the tagging inefficiency with a very good accuracy ( $10^{-5}$  level). In the neutral case, events where a photon has made a conversion before the spectrometer as well as  $K_S \rightarrow \pi^0 e^+ e^- \gamma$  decays are used.

Because of high rates in the tagger, a fraction of  $K_L$  decays fall accidentally in time

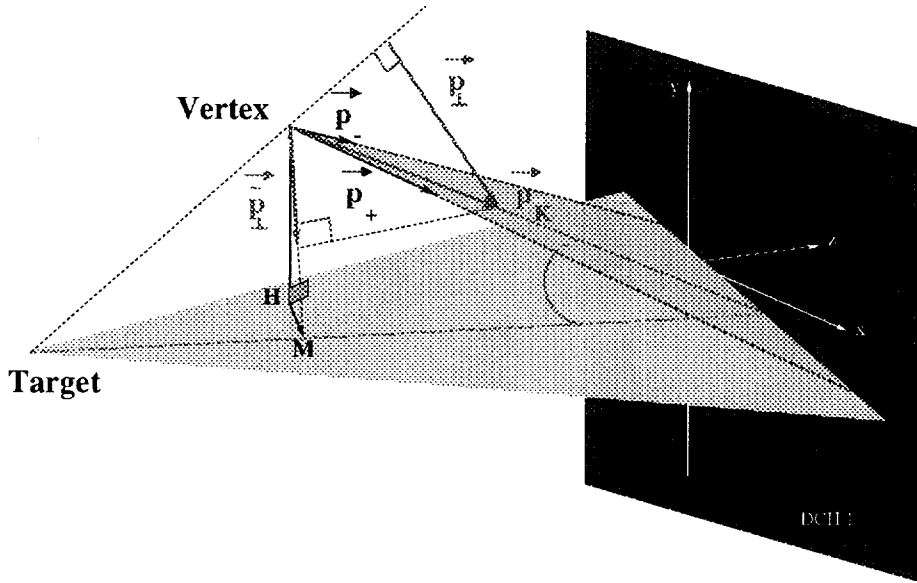

Figure 2:  $\tilde{P}_\perp^2$  definition

with a proton. This causes  $K_L \rightarrow K_S$  transitions. Such transitions cannot produce artificially a non zero  $\text{Re}(\epsilon'/\epsilon)$  value but they deteriorate the resolution on the double ratio. Again, error on the double ratio only comes from uncontrolled differences between charged and neutral modes. In the charged mode, this kind of transition is measured to be  $\sim (1.4 \pm 0.1) \times 10^{-4}$ . The difference of  $K_L \rightarrow K_S$  transitions in charged and neutral modes is directly measured. The effective rates seen by the charged and neutral  $K_L$  decays are compared in side bands of the coincidence window and are extrapolated to the tagging window. The precision of about  $5 \times 10^{-4}$  obtained on this measurement translates into an uncertainty on  $\text{Re}(\epsilon'/\epsilon)$  of less than  $2 \cdot 10^{-4}$ .

## 2.2 Background subtraction

An important issue for the  $\text{Re}(\epsilon'/\epsilon)$  analysis is to keep the analysis cuts symmetric between  $K_S$  and  $K_L$  for each decay mode. In the charged mode, a useful physical quantity for the selection of two-body decays is the transverse momentum ( $P_\perp^2$ ) of the reconstructed kaon. However, the very different  $z$  location of the  $K_S$  and  $K_L$  targets lead to different  $P_\perp^2$  resolution for each beam. To overcome this difference, another quantity,  $\tilde{P}_\perp^2$ , constructed from the angle between the target plane and the decay plane, is used instead (see fig 2).

The main background sources to  $K_L \rightarrow \pi^+\pi^-$  are  $K_{e3}$  and  $K_{\mu3}$  decays which are by two orders of magnitude more frequent than  $\pi^+\pi^-$  decays. Most of the  $K_{e3}$  events are eliminated by identifying the electron in the e.m. calorimeter with an E/P cut while most of the  $K_{\mu3}$  events are vetoed by requiring no in-time hit in the muon counter. The shape of the background is evaluated in the mass-vs- $\tilde{P}_\perp^2$  plane with selected samples of  $K_{e3}$  and

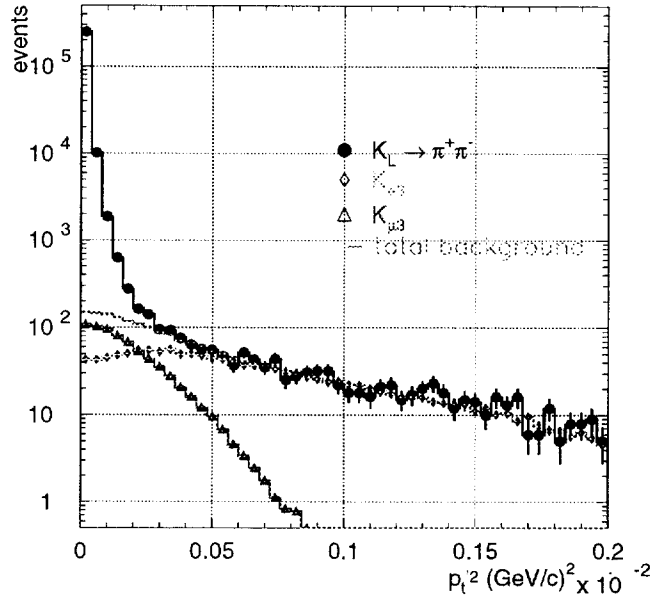

Figure 3: Charged background estimation

$K_{\mu 3}$  decays. The amount of remaining  $K_{e 3}$  and  $K_{\mu 3}$  events is then estimated in control regions and extrapolated to the signal region. With this procedure, the background is measured to be a few per mille with an accuracy ten times better (see fig 3).

Because  $K_L \rightarrow 3\pi^0$  decays occur 200 times more frequently than  $K_L \rightarrow 2\pi^0$  decays and can be misidentified if two photons are missed, they constitute the main background to the  $2\pi^0$  decays. Events with four in-time photons (within  $\pm 5$  ns) are selected if no additional cluster is reconstructed within 3 ns around the event time. The longitudinal position of the vertex is computed assuming a kaon decay. The photons are then paired to form the best  $\pi^0\pi^0$  combination.

The ellipse number,  $R_{\text{ell}}$ , correlates the sum of the  $2\pi^0$  mass and their difference.

$$R_{\text{ell}} = \frac{1}{9} \left\{ \left( \frac{m_1 + m_2 - m_{\pi^0}}{\sigma_{m_1 + m_2}} \right)^2 + \left( \frac{m_1 - m_2}{\sigma_{m_1 - m_2}} \right)^2 \right\}$$

It characterizes the size of the ellipse containing the signal. The background is estimated comparing the fraction of events with high value of  $R_{\text{ell}}$  for  $K_S$  and  $K_L$  (see fig 4). The background level in the signal region defined by  $R_{\text{ell}} < 1.5$ , is measured to be about  $3 \times 10^{-3}$ . It is reduced to  $\sim 1 \times 10^{-3}$  when the  $K_L$  are weighted with the lifetime. This is because the  $3\pi^0$  with missing photons tend to be reconstructed closer to the calorimeter.



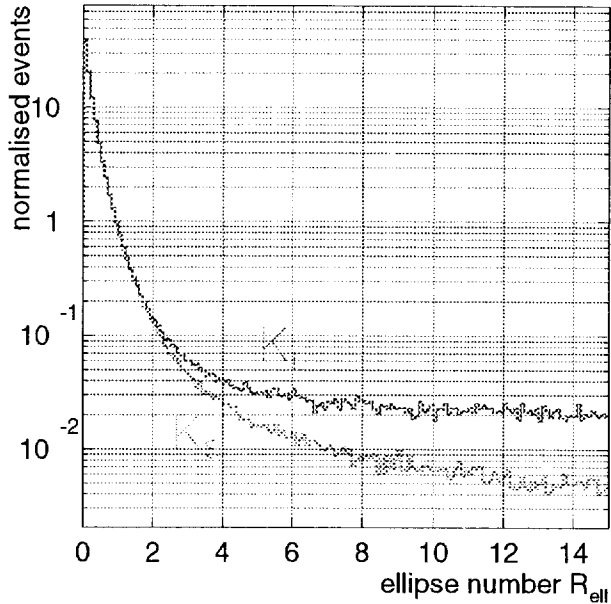

Figure 4: Neutral background estimation

### 2.3 Lifetime weighting and fiducial volume definition

The fiducial decay volume starts at the AKS longitudinal position. Its upstream end is effectively defined by a cut on the reconstructed lifetime of the kaon decay (typically  $3.5\tau_S$ ). Vetoing the event where a  $K_S$  decay occurs before the AKS provides a sharp determination of the beginning of the  $K_S$  decay region which is insensitive to the distance scale. The measured  $z$ -scales for  $\pi^+\pi^-$  and  $\pi^0\pi^0$  are adjusted to the AKS anti-counter position and the downstream end of the  $K_L$  decay region is defined at the same reconstructed longitudinal position. An error on the relative charged-vs-neutral energy scale would simply shift the upstream and downstream ends of the  $K_L$  decay region by the same amount. Since the  $K_L$  lifetime distribution is reasonably flat in the considered range, the effect cancels globally. On the other hand, the  $K_S$  vertex distribution is quite steep at the AKS position and this cancellation does not work. The use of the AKS detector considerably reduces the sensitivity of the double ratio to the energy scale.

To reduce the systematic error coming from the different  $z$  dependance of neutral and charged modes, the  $K_L$  events are statistically weighted as a function of lifetime. This method reduces the acceptance correction to less than 0.5% at the cost of  $\sim 40\%$  loss in statistical power for  $K_L$  decays.

## 2.4 Other sources of systematics

Effect of accidental activity in the detector should *a priori* cancel between  $K_L$  and  $K_S$  since the two beams are observed concurrently. To verify this assumption, events proportional to  $K_L$  and  $K_S$  beams intensity are collected independently of the activity in the detector. The gains and losses of good events due to accidental activity is then evaluated for  $K_L$  and  $K_S$  by overlaying such events with selected 2 pion decays.

The acceptance corrections, which are small after  $K_L$  weighting, are computed from Monte-Carlo simulation taking into account the detailed detector geometry and the response function of the various components of the NA48 detector.

Other sources of systematic uncertainties such as detector non-linearity, the neutral-charge relative energy scale, detector stability are also being investigated and studied carefully.

## 3 1998 data taking

Several improvements have been achieved during the winter shutdown. All the blocking capacitors of the e.m. calorimeter have been replaced, allowing for stable operation of the detector at 3 kV. A new carbon-fiber beam pipe has been installed, reducing by  $\sim 30\%$  the activity in the drift chambers. The L2 charged trigger has been upgraded with 200 MHz processors. This allowed to work with higher input rates and more complex algorithms for the event selection (e.g study of the  $K_L \rightarrow \pi^+\pi^-e^+e^-$  mode).

In 1998, the data taking period lasted from mid-May until beginning of September. About  $2 \times 10^6$   $K_L \rightarrow \pi^0\pi^0$  were recorded. Some 75 Tbytes of data have been recorded on tape and are being reprocessed with the final detector calibration.

## 4 Prospects and conclusion

The analysis of the 1997 data is in progress and should provide a result on  $\text{Re}(\epsilon'/\epsilon)$  with a precision comparable to previous experiments. Data taking will continue in 1999 and 2000 ( $\sim 120$  days/year) to achieve a precision of  $2 \times 10^{-4}$  on  $\text{Re}(\epsilon'/\epsilon)$ .

## References

- [1] Barr G.D., *et al.*, CERN/SPSC/90-22/P253
- [2] Barr G.D., *et al.*, *Phys. Lett.* **B317** 233 (1993)
- [3] Gibbons L.K., *et al.*, *Phys. Rev. Lett.* **70** 1203 (1993)
- [4] Doble N., *et al.*, *Nucl. Instr. Meth.* **B119** (1996) 181

- [5] Bergauer H., *et al.*, *Nucl. Instr. Meth. A* **419** 623-631 (1998)
- [6] Bédérède D., *et al.*, *Nucl. Instr. Meth. A* **367** 88 (1995)
- [7] Ocariz J. , *et al.*, *Preprint LAL-98-108* (hep-ex/9901013) (8p) (1999).// To be published in the proceedings of IEEE '98 NSS proceedings
- [8] Anvar S., *et al.*, *Nucl. Instr. Meth. A* **419** 686-694 (1998)
- [9] Gorini B., *et al.*, *IEEE Trans. Nucl. Sci.* **45** 1771-5 (1998)