

KEK Preprint 98-11  
April 1998  
A

# High Field Experiment of 1.3 m-long X-Band Structure



5w9826

T. HIGO, D. DONG, H. FANG, J. NIE, M. GAO, E. KADOKURA, I. MEJUEV,  
H. SAKAI and K. TAKATA

*Submitted to the First Asian Particle Accelerator Conference, APAC98,  
KEK, Tsukuba, Japan, March 23 - 27, 1998.*

**High Energy Accelerator Research Organization (KEK), 1998**

KEK Reports are available from:

Information Resources Division  
High Energy Accelerator Research Organization (KEK)  
1-1 Oho, Tsukuba-shi  
Ibaraki-ken, 305-0801  
JAPAN

Phone: 0298-64-5137  
Fax: 0298-64-4604  
Cable: KEK OHO  
E-mail: [Library@kekvox.kek.jp](mailto:Library@kekvox.kek.jp)  
Internet: <http://www.kek.jp>

# HIGH FIELD EXPERIMENT OF 1.3M-LONG X-BAND STRUCTURE

T. Higo, D. Dong\*, H. Fang\*, J. Nie\*, M. Gao\*, E. Kadokura, I. Mejev, H. Sakai and K. Takata  
KEK, High Energy Accelerator Organization, Oho 1-1, Tsukuba, Ibaraki, 305 Japan

\* IHEP, P. O. Box 918, Beijing 100039, P. R. China

## Abstract

Two 1.3m-long X-band accelerating structures were made to study the fabrication of the structure for the main linac of linear collider. One of the structures is being high-power tested to confirm the basic high field performance of such a full-scale structure. Various experimental instrumentations were carefully prepared; recording the RF pulses as the breakdown occurs, recording the timing, position and strength of X-rays along the structure, measuring dark current towards upstream and downstream along the beam axis, etc. Using these monitoring devices, the process of conditioning for the structure until reaching the specified field level or beyond is being studied. In the present paper are described those instruments and a preliminary conditioning result up to a power level of 1 MW.

## 1 INTRODUCTION

Studies of breakdown limit of the accelerating structures showed the possibility of the surface field of 600MV/m at X-band cavity[1]. However, when we consider much lower value of practical operating field at S-band in a multi-cell traveling-wave structure comparing to that of the breakdown limit, we should estimate also a much lower field at X-band in a multi-cell traveling-wave structure. In order to study the feasible field level at X-band for linear collider, several high field experiments have been performed until now[2,3].

A 20cm long structures, consisting of cells machined using a diamond tool, were tested up to 65MV/m with about 10 $\mu$ A of dark current[2]. For a longer structures, SLAC performed a few tests reaching nearly 70MV/m with a dark current of 1 mA[3]. It seems that the dark current greatly increases as the number of cells increases. We should study various effects associated with this large dark current and evaluate the performances at the nominal operational level of 73MV/m, which is the design field level without beam loading for the detuned accelerating structure of JLC[4].

One of two prototype detuned structures, IH1, is being high power tested at KEK. This paper describes the details of the test setup and the measurement system of various mechanisms associated with a high field operation. Another detuned structure, M2, is waiting for high power test at SLAC aiming at an extremely high power level such as more than two times higher than the nominal value of JLC. The experimental study of IH1 at KEK should be a complementary test. Here we try to record the conditioning

process from the beginning to the final level so that we can evaluate the conditioning process when we compare various conditioning cases in the future.

## 2 TEST STRUCTURE

The tested structures are "detuned structure" of 1.3m-long and described in detail in reference [4]. The cell geometries vary as function of cell number as shown in Fig. 1. Parameters and performances measured in low power are listed in Table 1.

Table 1. Parameters of tested detuned structure.

| item                  | design | measured      |
|-----------------------|--------|---------------|
| number of cells       | 150    | 150           |
| attenuation parameter | 0.58\$ | 0.59          |
| Input VSWR*           |        | < 1.2*, 1.07# |
| output VSWR**         |        | 1.2**, 1.02#  |
| filling time          | 106ns  | 112 ns        |

\* +/- 30MHz, \*\* +/-10,-20MHz, # at 11.424GHz.

\$ Q value is assumed to be 100% of theoretical one.

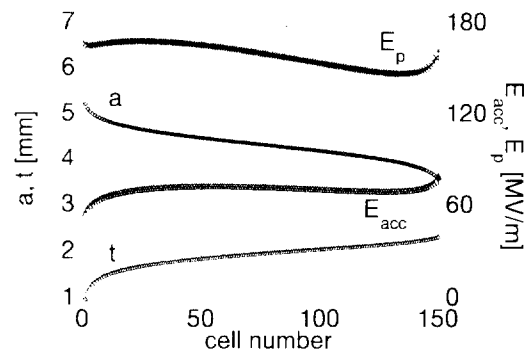

Figure: 1 Parameters of tested detuned structure. a if beam hole radius and t the disk thickness.  $E_{acc}$  is the average accelerating field in a structure without beam loading.  $E_p$  is the maximum surface field.

The formula for obtaining the average accelerating field along the structure  $E_{acc}$  from input power level is

$$E_{acc} [\text{MV/m}] = 73 \text{ Sqrt} ( P_{input} [\text{MW}] / 130 ).$$

Some details as for the fabrication processes are described in the following in order to clarify the characteristics of the structure. This information is useful to the discussion while comparing various experimental results. The cells were machined in 1995. After storage for longer than half a year, the cells were rinsed with acetone in ultrasonic bath, surface treated with Hcl weak acid bath,

followed by pure water rinsing and finally dipped in an acetone bath to evaporate the solution. Then the cells were assembled in a clean room of class 10000 and diffusion bonded at 890°C in vacuum furnace. Low power test was done in a condition being purged with a nitrogen gas. Finally the outgassing rate of the structure was measured two times each starting with exposed to air. It was found that the main residual gasses are with a mass number of 18, 28 and 44, meaning that there is much water and CO or CO<sub>2</sub> on the surface or inside of the structure. Baking was not performed.

### 3 EXPERIMENTAL SETUP

#### 3.1 System layout

The output power from two klystrons are combined with 3dB hybrid to feed the structure. The power in a rectangular wave guide is divided into two through a Tee junction being matched with three stub upstream side of the Tee. The divided powers are fed to the structure through two symmetrically placed coupler irises. The vacuum is evacuated by four ion pumps which are located at the input and output wave guides. A schematic layout of the system is shown in Fig. 2.

In the upstream side of the beam pipe, current transformer (CT), an isolation duct (ID) and Faraday cup (FC) are placed. From the output coupler to the downstream side, there are set a CT, a profile monitor (PM) made of Demarquest, an analyzer magnet (AM), ID and a FC. In the direction of 45° bending are placed a movable slit (SL), ID and FC.

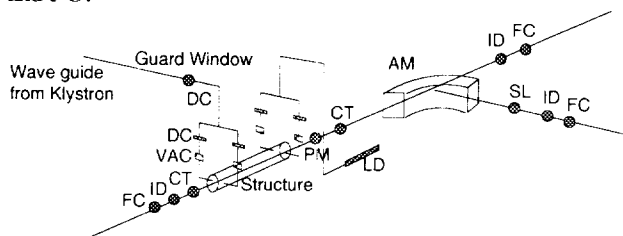

Figure: 2 Layout of experimental setup.

#### 3.2 Control and monitoring using InTouch

Control system is based on two front-end PLC's and Wonderware InTouch. The system is shown in Fig. 3. Auto conditioning program is implemented as InTouch script.

Java is used for remote monitoring application running on various operation systems such as MAC, UNIX and Windows. It uses Wonderware Scout Outpost, communicating to InTouch by DDE. Outpost provides the possibility to retrieve control data by CGI requests from Java applet.

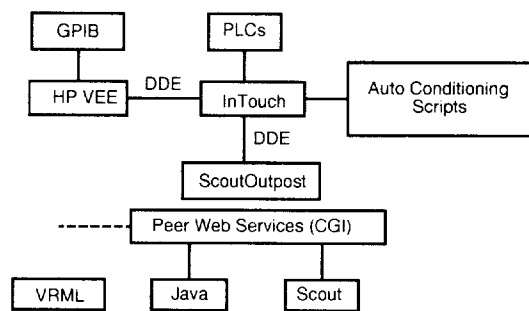

Figure: 3 Architecture of control and monitoring system for high field experiment of X-band structure.

#### 3.3 Pulse wave form recording by HP VEE

For saving the waveforms, HP-VEE is used connecting between PC and oscilloscope through GP-IB. If interlock happens or if manual acquisition button is pushed, VEE application receives a notification from InTouch by DDS connection and initiate the process of retrieving. It takes a few seconds for retrieving three traces. The read data is stored into file for off-line analysis afterwards.

#### 3.4 X-ray detection system

Several plastic scintillators (SC) are located along the structure to measure the X-rays coming out of structure. The scintillator is 13.5mm in diameter and 20mm in length and directly connected to photomultiplier tube (PMT). Lead collimations are located between the scintillator and structure with a circular hole of 14mm in diameter and 30mm in length. The side of the scintillator and photomultiplier tube is shielded by lead of at least 22mm in thickness. The PMT is type R212 with 9-stage and 15mm in diameter[5].

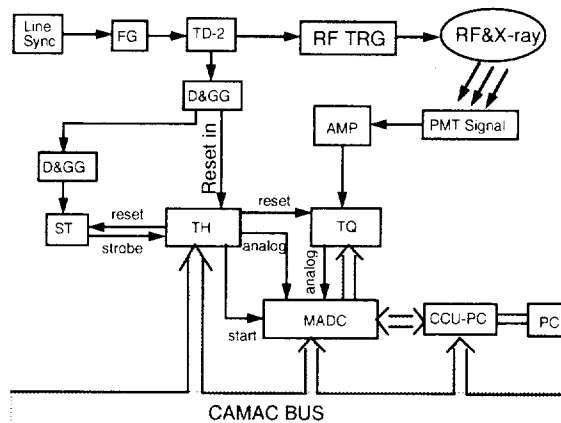

Figure: 4 Block diagram of the X-ray detection system. Line Sync = line synchronized timing module, FG = function generator, TD-2 = time delay module, RF TRG = RF timing supply module including high power RF system, D&GG = delay & gate generator, ST = strobe module, TH = threshold detection and timing module, TQ = time and charge detection, MADC = multi-channel ADC.

The anode signal is transported through 25m-long cable (8D) and supplied to electric circuit. A schematic block diagram of the circuit system is shown in Fig. 4. It measures the time difference between RF head and the X-ray signal. It also measure the total charge of the pulse. It may integrate many pulses if they overlap. The timing chart of the circuit is shown in Fig. 5.

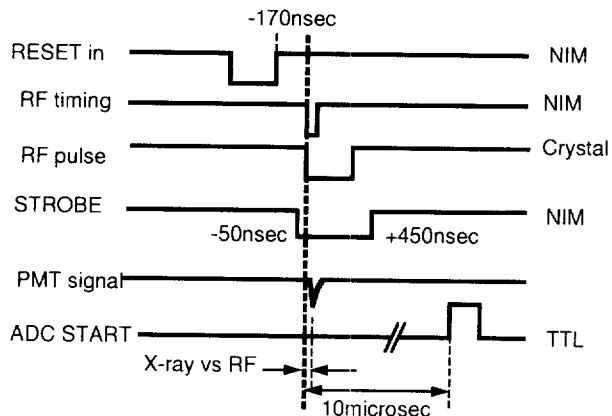

Figure: 5 Timing chart of the X-ray detection system.

The gain calibration of the PMT was performed by supplying a light from a LED with pulse length of 1 $\mu$ s and measure the output from ADC. The gain was adjusted by varying the applied voltage.

The threshold level can be changed from software. This level should be varied to obtain an optimum measurement condition depending on the experimental condition.

All this system is controlled via software written in DOS-3.1 because all the drivers of CAMAC modules are written in the operating system. At a moment, then, the taken data are off-line analyzed by transferring to other PC.

### 3.4 300MeV magnet

A 45° analyzer magnet was made at IHEP, China. Maximum energy is 300MeV. The good field region is  $\pm$ 1cm from center orbit. Magnetic field was measured using hole probe. This can analyze the dark current toward downstream with a resolution of 1% level.

## 4 PRESENT CONDITIONING STATUS

The conditioning has been done in parallel to preparing various experimental instrumentation. Typical conditioning parameters are as follows; pulse width is 350nsec and pulse repetition rate is 50Hz. The conditioning curve is shown in Fig. 6. The interlock level as for the vacuum was set to  $1 \times 10^{-4}$  Pa. All the interlock were due to abrupt jump of the vacuum near the input coupler region. The vacuum jump seems to occur at some particular power level, indicating some mechanism such as multipactoring. An input power

of 1MW corresponds to the accelerating field of only 6MV/m.

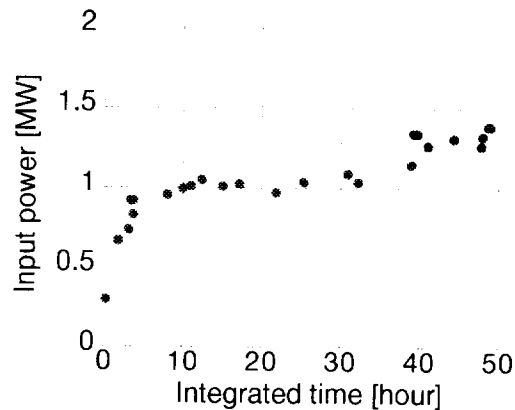

Figure: 6 Conditioning curve. Peak power input versus integrated period of conditioning.

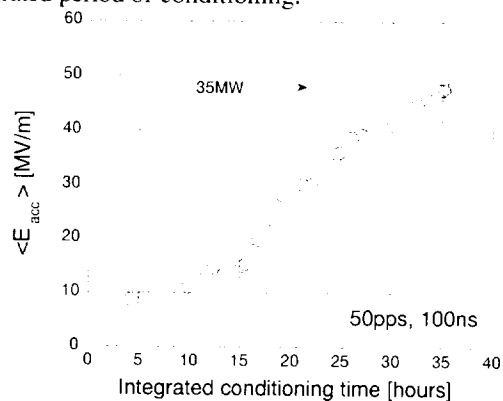

Figure: 7 Conditioning curve of 30cm-long structure.

In Fig. 7 are plotted the conditioning curve for 30cm-long structure. It reached the top field of 50MV/m (35MW input power) in only 40 hours. Comparing to this case, the present conditioning takes much more time. It might be due to larger number of cells or longer pulse length. It might also be due to such conditions as the long storage period, exposure to air, contamination with carbon related materials, etc. These should be studied in the following experiments.

## 5. ACKNOWLEDGMENTS

The authors greatly thank Prof. W. SuHong for a continuous support for collaborative works at IHEP, China, with KEK. They thank Dr. W. Xu for fabrication and field measurement of the magnet.

## 6. REFERENCES

- [1] J. W. Wang, SLAC-339.
- [2] T. Higo et al., Particle Accelerators, Vol 48, pp.43-59, 1994.
- [3] J. W. Wang et al., Proc. XVIII Int. Linear Accelerator Conf., LINAC96, p656, Geneva, Switzerland, 1996.
- [4] "JLC Design Study", KEK-Report 97-1, 1997.
- [5] Beijing Hamamatsu Photoelectric Co., China.

